



**SLINGSHOT**



**POLARIS**



# Team Tips

ARTICLE: T-17-01-01

DATE: February 23, 2017

Published for Polaris Dealerships, Distributors, and Service Technicians

## SUBJECT: SLINGSHOT – T-16-06 Proper Swingarm Installation

### MODELS: 2015-2017 SLINGSHOT MODELS

Slingshot has had a small but concerning number of post bulletin repair contacts due to failure to properly assemble the rear axle, sprocket and nuts. Improper installation may result in a rear axle assembly with insufficient clamp load. When proper clamp load is not achieved, the vehicle may experience erratic or incorrect rear wheel speed sensor readings. Symptoms include a reduction in deceleration during engine braking and a feeling of cruise control being engaged or the ABS solenoid being activated during light to moderate braking. This may occur when the axle splines or sprocket splines are not properly cleaned to remove corrosion or Loctite® prior to reassembly.

Critical steps are outlined in Safety Bulletin T-16-06 to properly clean the axle and nuts.

### IMPORTANT

Make sure that steps 1 & 2 of the PREPERATION section are being performed properly to insure the swingarm is installed correctly.

#### PREPERATION:

1. Thoroughly clean pivot shaft, pivot nut and all bushings removed from the original swingarm with contact cleaner.
2. Remove all Loctite residue. Using degreaser and a wire brush, thoroughly clean axle splines ④, threads ③ and the sprocket splines ② before installation.

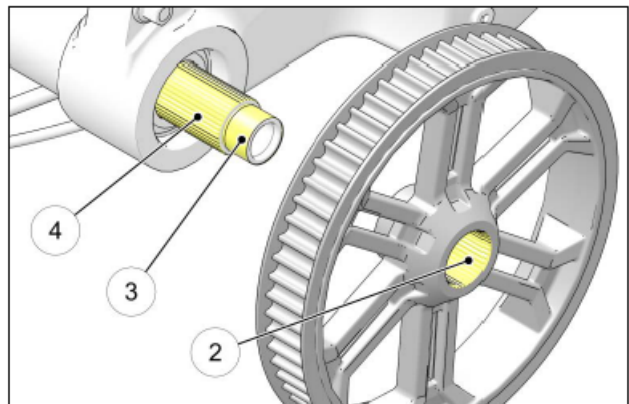

#### CRITICAL

Removal of all Loctite material is a labor intensive process and may take up to 10 minutes or more to complete. It is critical that these surfaces are clean and no residual Loctite material or corrosion is present.

**When properly installed, the axle threads should extend beyond the outside rear axle nut as shown.**

