

FT4924 Curbside Exterior Mirror Water Intrusion

Technical writer name
Devanand

Manual section 18

First Level Parts		
Material	Part Number	QTY
-	-	-

Nb hours Level 1 0.25 hr
 Nb hours Level 2 0.5 hr
 MQR 7621-2085

Second Level Parts (50% of 191 vehicles)		
Material	Part Number	QTY
GASKET MIRROR	N65176	1
GASKET MIRROR SAFEFLEET LH 1/4	N91045-01	1
GASKET MIRROR SAFEFLEET LH 3/8	N91045-02	1
GASKET MIRROR SAFEFLEET LH 1/2	N91045-03	1
NUT LOCKNYL M10 YZ TRIV 96H G8	N11243	3

Note: Each vehicle will use only 1 of these 3 gaskets

Shop Supply (100% of 191 vehicles)		
Material	Part Number	QTY
SEALANT BUTYL 757	N32989	0.33

Note:
 N32989 SEALANT BUTYL 757)
 0.33 bottle/Bus
 32 bottle for the entire campaign

Disposal of parts		
Removed parts are:		When the retained check box is checked, the parts must be retained and returned in accordance with the usual warranty procedure to be reimbursed.
Discarded	Retained	
x	-	

Client	Order	Road numbers	VIN	QTY	Lang.	Customer	Target market	Plant	Config moteur	Model	NR	R1
New York City Transit - New York	LA76	8564 8633	L82J4K9777075 L82J8K9777144	70	E	NYCT	US	PLB	TD	40	x	
New York City Transit - New York	LC32	8634 8754	L82JXK9777145 L82J5K9777277	121	E	NYCT	US	PLB	TD	40	x	

Jean-Nicolas Fournier
 Digitally signed by Jean-Nicolas Fournier
 DN: cn=Jean-Nicolas Fournier, o=Newa Bus, email=jean-nicolas.fournier@volvo.com, c=CA
 Date: 2020.08.26 11:51:20 -0400

Service Instruction

QJ 7621- 2085 – Curbside Exterior Mirror Loose and Water Intrusion

GENERAL INFORMATIONS

Document	REV	Date	By
Curbside exterior mirror loose and water intrusion	1	6/23/20	J. Vaughan

Order Affected / Effectivity	Road Number	Customers	QTY
LA73, LA76, LB78, LC32	8504-8754	NYCT	251

SYSTEM and PARTS:

System Name	Exterior mirror
Option	518112.74, 518112.82
Drawing	518112NB20, 518112NB22
Part	N90681, N78549

Reason for Modification / Background:

1. Inspect the presence of water traces inside the bus, the condition of the gasket and the torque of the hardware 39Nm. If anything wrong is found, go to level 2.
2. Remove the mirror, replace the gasket by a new one, reapply the butyl according to Nova's guidelines and reassemble the hardware to the correct torque of 39 Nm

Cause of Failure:

Workmanship issue when exterior mirrors were being removed to paint the bus and not installed back on according to the installation instructions

MATERIAL

BOM for Mirror N90681 (L959, LA23, LA73, LA76-1to55, LB29/99, LB59, LB78)					
Item	QTY	PART NO	REV	DESCRIPTION	REPLACES PART N°
LEVEL 1 – No parts					
LEVEL 2					
1	1	N65176		Gasket (needed for both types of mirrors)	same
2	1	N32989		Sealant Butyl	same
3	1	N35120		Spacer 7.9mm	
4	3	N11243		Nut Locknyl M10 YZ TRIV 96H G8	

BOM for Mirror N78549 (LA76-56to125 and LC32)					
Item	QTY	PART NO	REV	DESCRIPTION	REPLACES PART N°
LEVEL 1 – No parts					
LEVEL 2					
1	1	N65176		Gasket (needed for both types of mirrors)	same
2	1	N32989		Sealant Butyl	same
3	1	N91045-01 or 02 or 03		Spacer 1/4" or 3/8" or 1/2"	same
4	3	N11243		Nut Locknyl M10 YZ TRIV 96H G8	same

SRT	Type	Time
	Inspection, torque	15 minutes
	Removal, replacement, reapplication, torque	30 minutes

SPECIAL INSTRUCTION / IMPORTANTE NOTICE

No	Tools Needed:
1	Torque wrench
2	Socket
3	Torque seal

Important notices

LA73 (8504-8507) exterior mirror N90681
 LA76-01 to LA76-55 (8508-8563) exterior mirror N90681
 LA76-56 to LA76-125 (8564-8633) exterior mirror N78549
 LB78 (8526) exterior mirror N90681
 LC32-01 to LC32-121 (8634-8754) exterior mirror N78549

DESCRIPTION / WORK INSTRUCTION

Level 1

1. Locate the curbside exterior mirror



2. Inspect for presence of water traces inside the A pillar. If water found, go to level 2



3. Visually inspect the condition of the gasket. If gasket is damaged, go to level 2



8615 = LA76-107
8744 = LC32-111

4. If no issues identified with water intrusion or gasket, torque 3x hardware to specification of 39 ± 5 Nm (28.8 ± 3.4 ft lbs) using a torque wrench and socket. Apply torque seal. **Level 2 is not needed.**

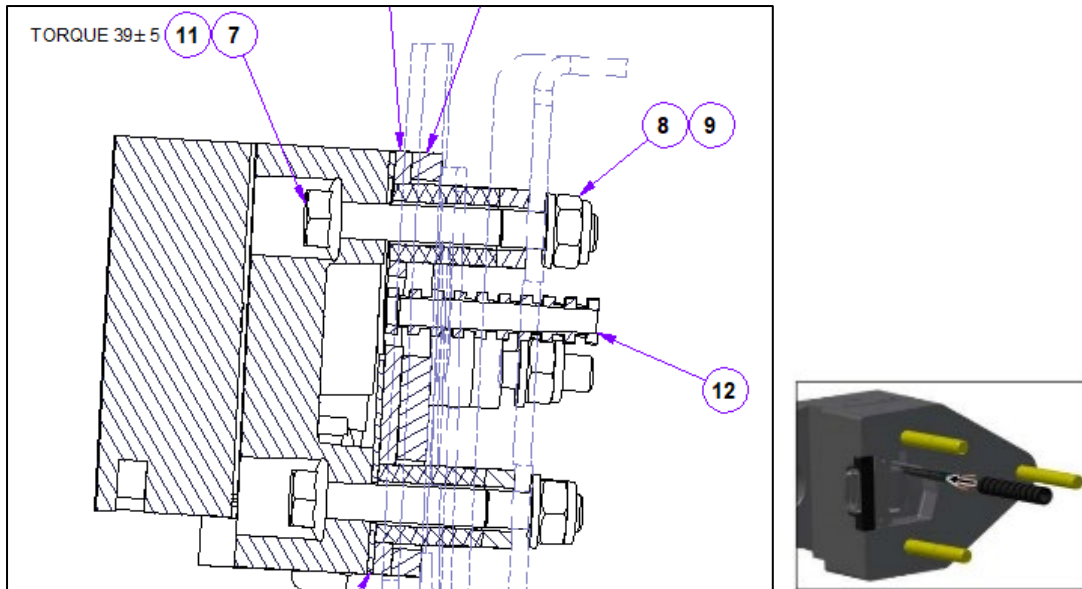

Level 2

5. For the mirror N78549 only : Make sure that the hardware is torqued to 39 N.m.
6. Measure the gap between the front shell and the metallic mirror support :

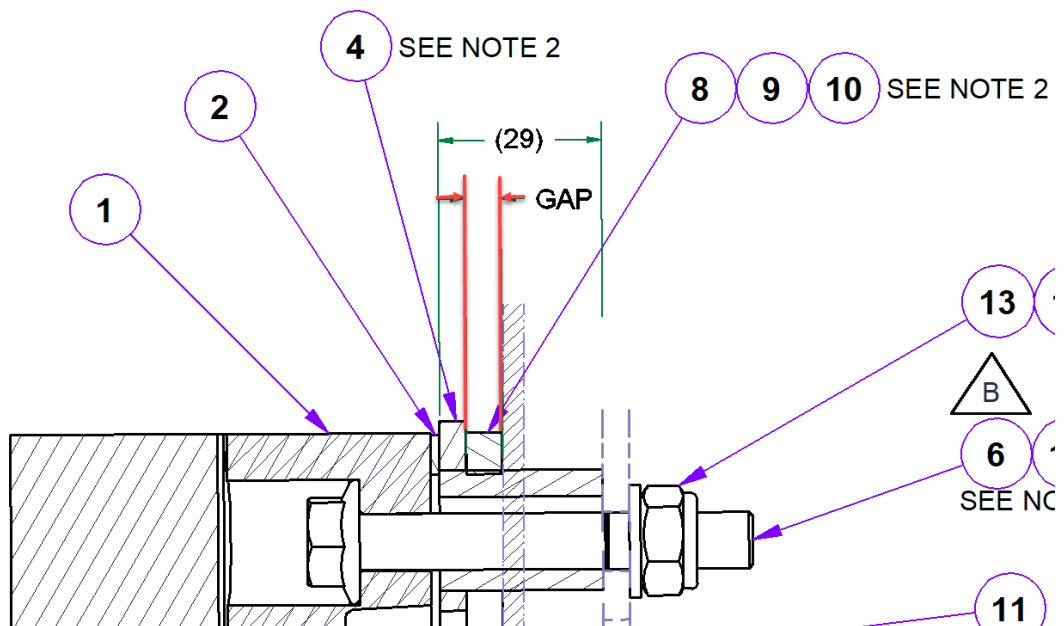

7. Use the table below to select the new neoprene spacer to be used:

GAP (mm)	USE GASKET	COMPRESSION (mm)
3	N91045-01 (1/4")	3
4	N91045-01 (1/4")	2
5	N91045-01 (1/4")	1
6	N91045-02 (3/8")	3
7	N91045-02 (3/8")	2
8	N91045-02 (3/8")	1
9	N91045-03 (1/2")	3
10	N91045-03 (1/2")	2
11	N91045-03 (1/2")	1

8. Remove the mirror using the socket wrench. Discard the used locknuts.

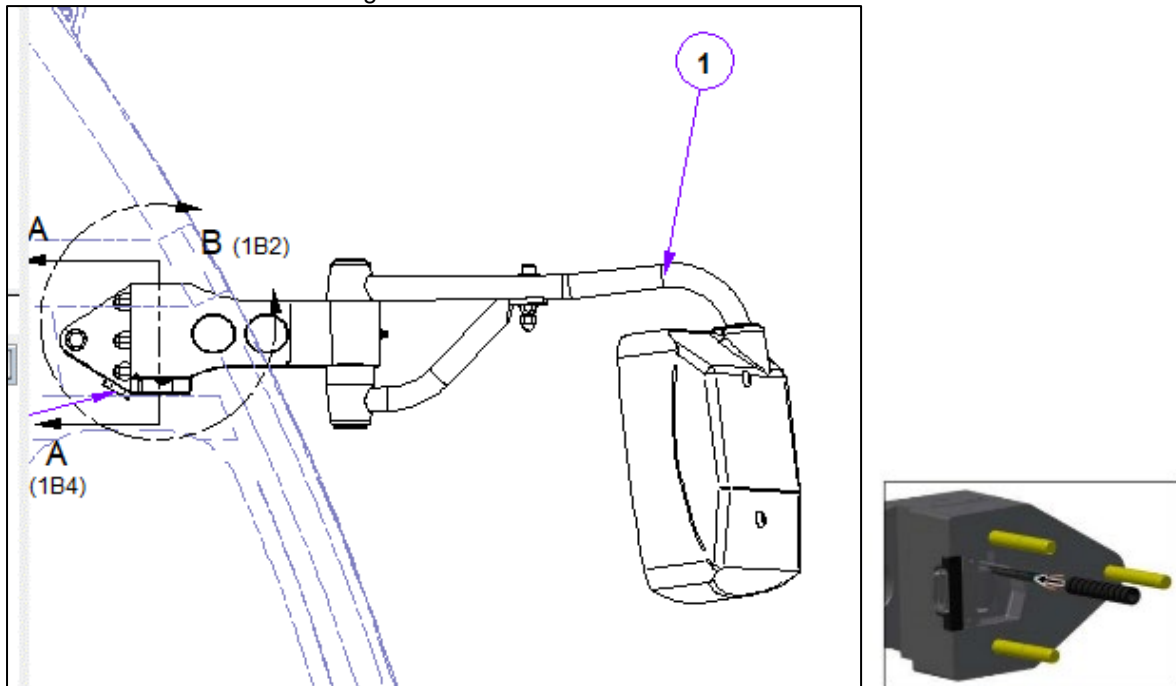

9. Replace the gasket N65176, neoprene spacer (N35120 for mirror N90681; N91045-01/02/03 for mirror N78549) and locknuts N11243 with new ones.

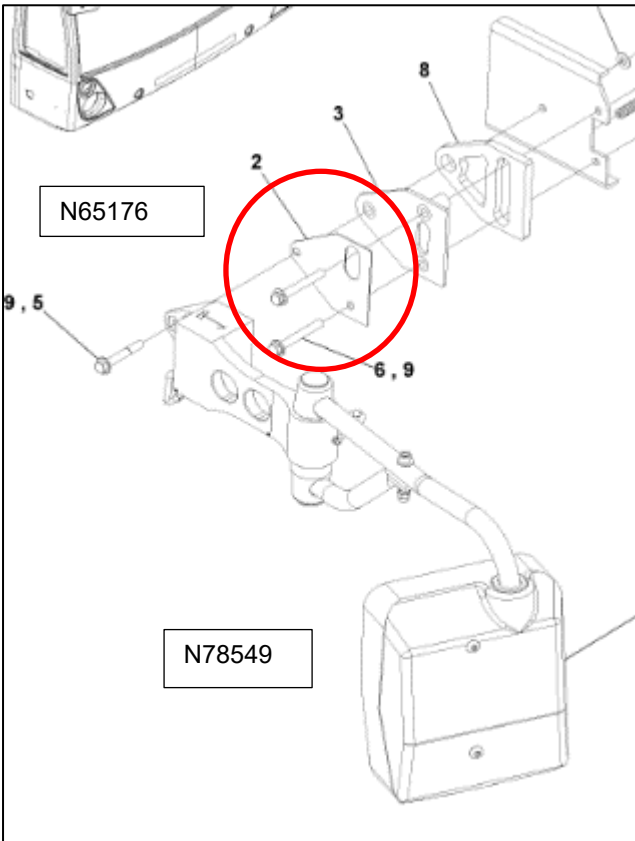
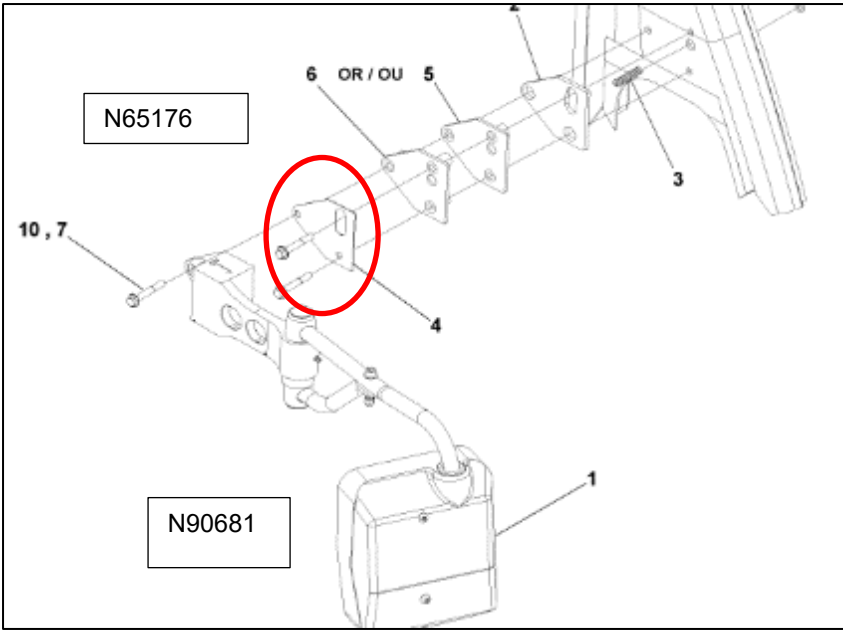

10. Reapply butyl N32989 on the perimeter and around the holes on both surfaces on the gasket N65176 and N35120 (for mirror N90681) or N91045 (for mirror N78549)



Incorrect application of butyl (complete layer)

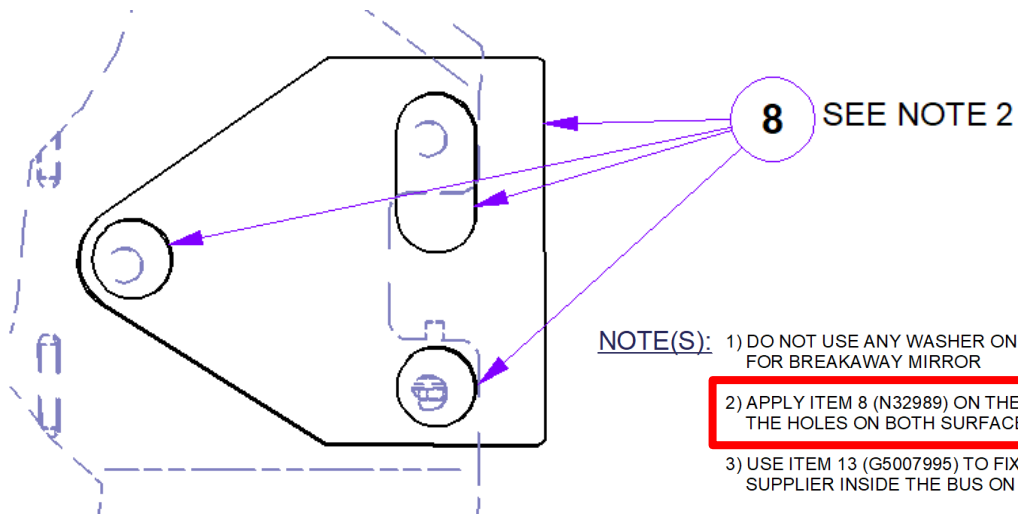

DETAIL B
 ITEM OMITED FOR CLARITY
 (1C8)

Correct instruction to apply butyl

11. Reinstall the mirror using the same hardware. Torque hardware to 39Nm and add torque seal

