



# THULE® REGAL AWNING INSPECTION

TSB Number:	TSB 01-004-20B
Product:	Thule® Regal Awning
Date:	June 19, 2020

**NOTE:** This bulletin supersedes TSB 01-004-20 dated April 17, 2020, which should be removed from your files.

## Purpose

This document outlines the inspection (and correction) of Thule Regal Awnings to determine if there is too much gap between the roll tube and end plates, which could cause the fabric to extend over the edge or the roll tube could shift along the axle plane.

## Safety

This document provides general instructions. Many variables can change the circumstances of any procedure, i.e. the degree of difficulty involved in the service operation and the ability level of the individual performing the operation. This document cannot begin to plot out procedures for every possibility, but will provide the general instructions for effectively installing, removing or servicing the system. In the event the skill level required is too advanced or the procedure too difficult, a certified technician should be consulted before performing the necessary operation. Failure to correctly install, remove or service the system may result in voiding the warranty, inflicting injury or even death.

### **⚠ WARNING**

The "WARNING" symbol above is a sign that a procedure has a safety risk involved and may cause death, serious personal injury, severe product and/or property damage if not performed safely and within the parameters set forth in this document.

### **⚠ CAUTION**

The "CAUTION" symbol above is a sign that a procedure has a safety risk involved and may cause personal injury, product and/or property damage if not performed safely and within the parameters set forth in this document.

## Resources Required

- Cordless or electric drill or screwdriver
- Appropriate drive bits
- Small hammer or mallet
- Micrometer
- Metric T-handle wrenches (optional)
- Flat head screwdriver or pry bar

## Thule Regal Tolerance Adjustment Kit

**NOTE:** Use parts as needed. Discard unused parts.

Thule Regal Tolerance Adjustment Kit - 2020115013	
Description	Qty
Instruction manual	1
Washers	6
Front end cap screw	1
Rear end cap screws	3
End plate screws	2
QA approved sticker (See figure 21)	1

## Labor Time

**Inspection: 0.3 hours (need two measurements)**

**Corrective Action: 0.3 hours(adding washers)**



# THULE® REGAL AWNING INSPECTION

TSB Number:	TSB 01-004-20B
Product:	Thule® Regal Awning
Date:	June 19, 2020

## Inspection

Check the following steps on the flow chart (Fig. 1 ) to determine if the awning needs to be modified.

**Fig. 1**

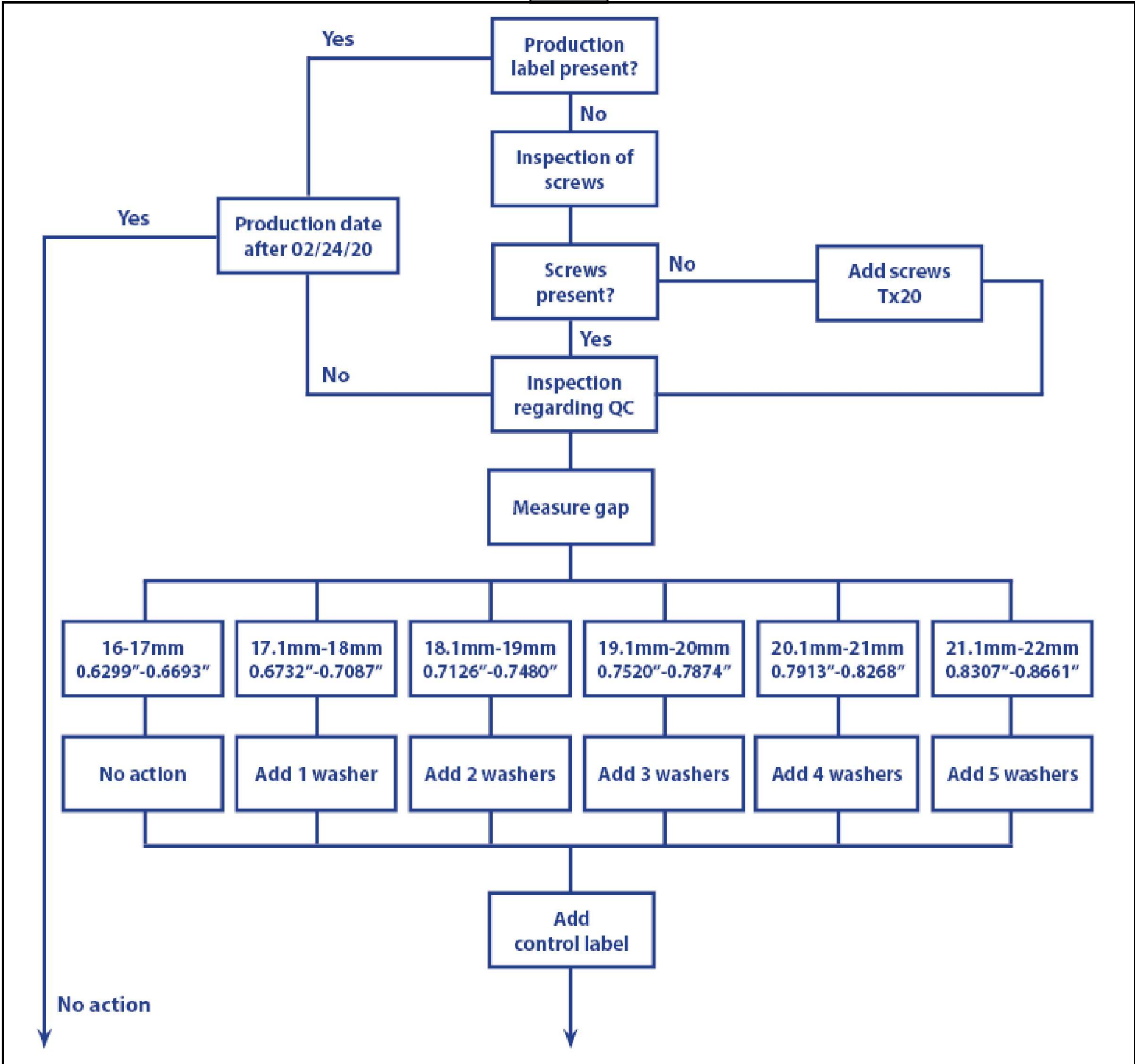

# THULE® REGAL AWNING INSPECTION

TSB Number:	TSB 01-004-20B
Product:	Thule® Regal Awning
Date:	June 19, 2020

## Production Label Inspection

1. Open the awning at least three feet.
2. Check for the production label (Fig. 2A) near the left hand end cap, inside the lead rail profile.

Fig. 2



**NOTE:** If the production label is not present, go to the Screw Inspection section on page 4. If the production label is present and dated (DD/MM/YY) prior to February 2020, skip to the Tolerance Inspection on page 5. If the production label is present and dated (DD/MM/YY) February 2020 or later, no further action is needed.



# THULE® REGAL AWNING INSPECTION

TSB Number:	TSB 01-004-20B
Product:	Thule® Regal Awning
Date:	June 19, 2020

## Screw Inspection

1. Physically move/rock the end caps to check fixation of the end plate with 20mm torx fasteners.  
**NOTE:** Visual inspection of the two 20mm torx fasteners (Fig. 6) will require removal of the end caps.
2. Open the awning at least three feet.

### ⚠ CAUTION

**Use caution removing the fasteners securing the end caps, they can easily be stripped.**

3. Remove the 15mm torx fastener securing the front end cap (Fig. 3) with appropriate bit.
4. Pop off the front end cap (Fig. 4A) with a flat head screwdriver or pry bar.

Fig. 3



Fig. 4



5. Remove the three 3mm hex fasteners (Fig. 5) securing the rear end cap with appropriate bit.
6. Verify the presence of the two 20mm torx fasteners (Fig. 6) on the awning end plate.

Fig. 5



Fig. 6

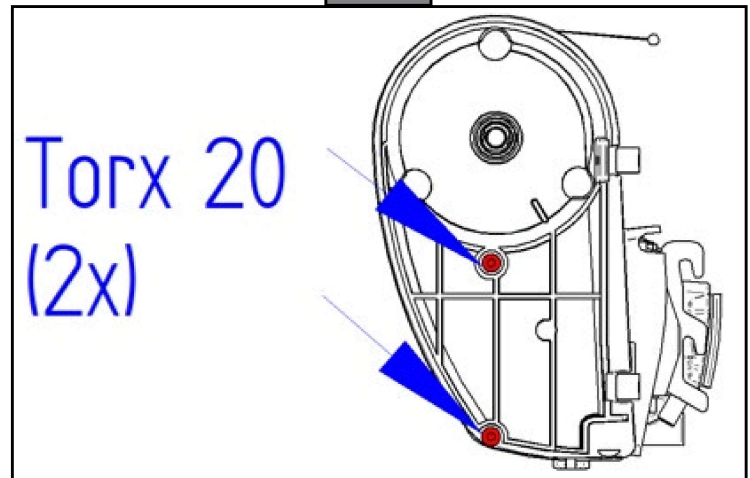

7. Repeat steps 2 through 6 for the other end cap. Retain all hardware for re-installation.  
If the fasteners are present on the awning ends, go to the Tolerance Inspection section on page 5. If the fasteners are not present, install the two 20mm torx fasteners provided.





# THULE® REGAL AWNING INSPECTION

TSB Number:	TSB 01-004-20B
Product:	Thule® Regal Awning
Date:	June 19, 2020

## Tolerance Inspection

**NOTE:** If the end caps have already been removed for screw inspection, skip to step 6.

1. Open the awning at least three feet.

**CAUTION**

**Use caution removing the fastener securing the front end cap, it can easily be stripped.**

2. Remove the 15mm torx fastener securing the front end cap (Fig. 7) with appropriate bit.
3. Pop off the front end cap (Fig. 8A) with a flat head screwdriver or pry bar.

Fig. 7



Fig. 8



4. Set front end cap (Fig. 8A) aside for re-installation.
5. Repeat steps 1 through 4 for the other end cap. Retain hardware for re-installation.
6. Using a micrometer measure the gap between the awning roll tube and end plates on both the right and left sides (Fig. 10).
7. Add the two measurements and see Tolerance Inspection Table on page 6 for measurement specifics.

Fig. 9



Fig. 10

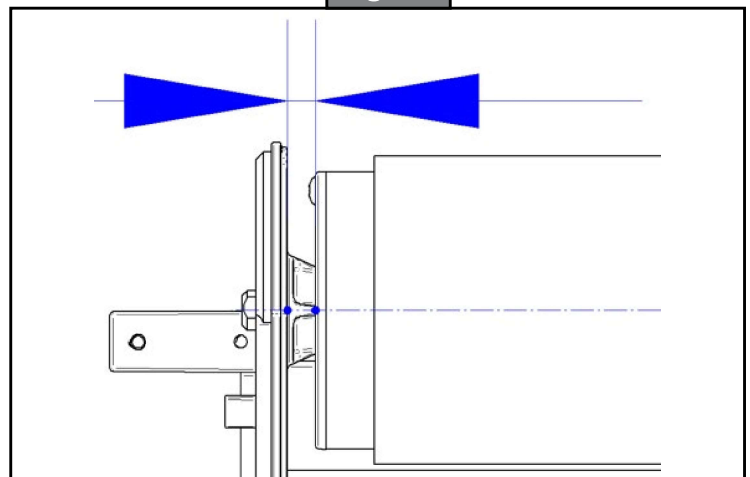

# THULE® REGAL AWNING INSPECTION

TSB Number:	TSB 01-004-20B
Product:	Thule® Regal Awning
Date:	June 19, 2020

## Tolerance Inspection Table

### Procedure

1. Measure the gap on the left and right sides (Fig. 11).
  - Measure at the axle centerline height.
  - The minimum is always 8mm (0.3150")

Fig. 11

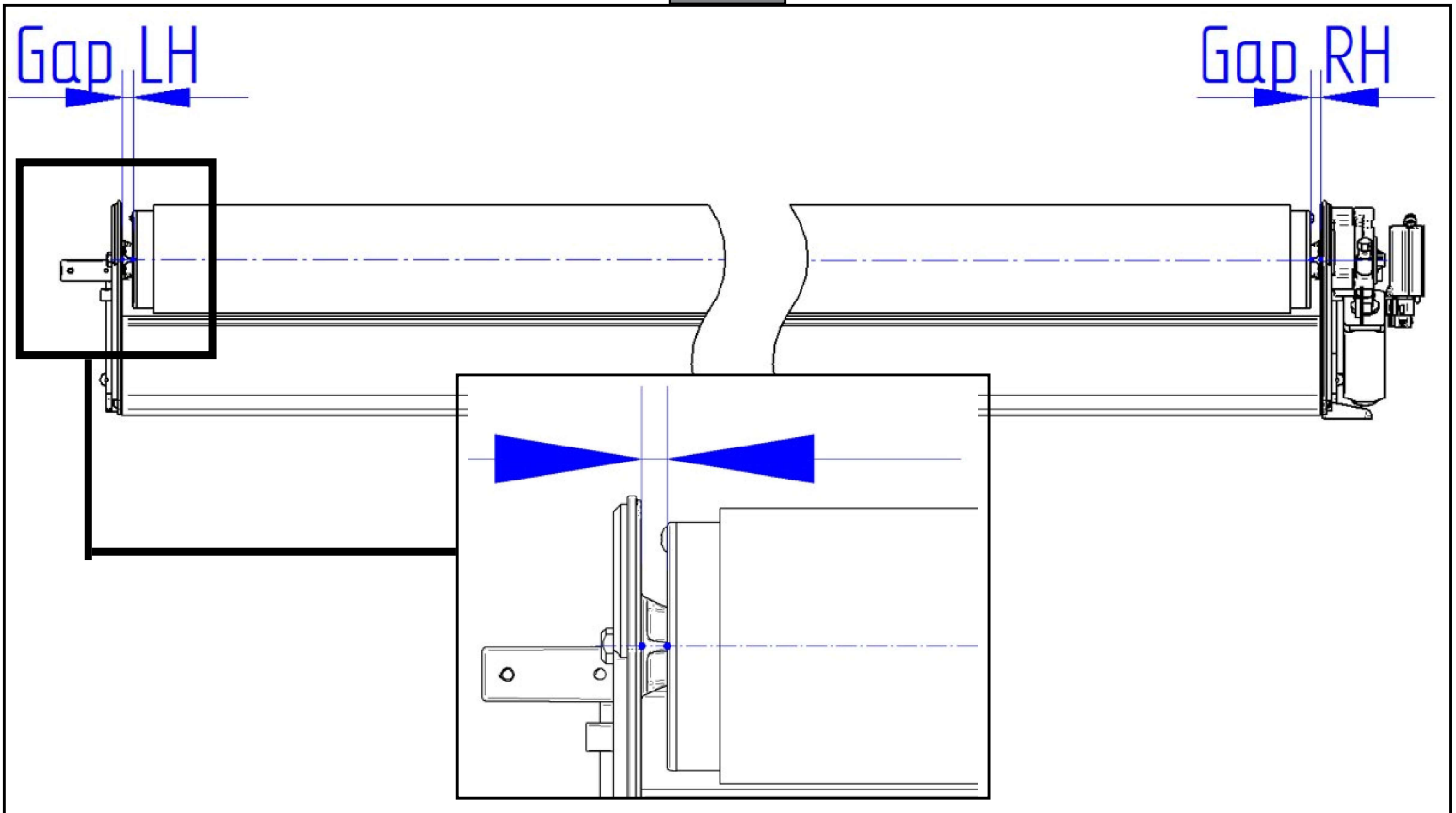

2. Add both values and compare with table below.

Gap sum (mm)	Gap sum (")	Action
16mm - 17mm	0.6299" - 0.6693"	No action
17.1mm - 18mm	0.6732" - 0.7087"	Add 1 washer (*)
18.1mm - 19mm	0.7126" - 0.7480"	Add 2 washers (*)
19.1mm - 20mm	0.7520" - 0.7874"	Add 3 washers (*)
20.1mm - 21mm	0.7913" - 0.8268"	Add 4 washers (*)
21.1mm - 22mm	0.8307" - 0.8661"	Add 5 washers (*)
(*) DIN988 A2 (16mm x 22mm x 1mm)		

3. See Corrective Action section on page 7 if washers need to be added.

TSB Number:	TSB 01-004-20B
Product:	Thule® Regal Awning
Date:	June 19, 2020

## Corrective Action

**NOTE:** This action should be performed on the left side only.

1. Open the awning completely.
2. Tie up the spring arms (Fig 12).
3. Release all the fabric tension. DO NOT proceed to step 6 until fabric tension is released.

**NOTE:** If the rear end cap has already been removed in a previous section, skip to step 6.

4. Remove the three 3mm hex fasteners securing the rear end cap (Fig. 13) using appropriate bit.
5. Remove rear end cap (Fig. 14).

Fig. 12



Fig. 13



Fig. 14



6. Remove the two 20mm Torx fasteners from the end plate (Fig. 15) using appropriate bit.
7. Remove the end plate (Fig. 16).
8. Add the necessary washers (Fig. 17) according to the table on page 6.

Fig. 15



Fig. 16



Fig. 17



# THULE® REGAL AWNING INSPECTION

TSB Number:	TSB 01-004-20
Product:	Thule® Regal Awning
Date:	June 19, 2020

9. Tap the axle with small hammer or mallet to eliminate excess play (Fig. 18).
10. Align the end plate on the axle (Fig. 19) and secure with previously-removed 20mm Torx fasteners (Fig. 20).

Fig. 18



Fig. 19



Fig. 20



11. Individually dry fit the end cap(s), taking care not to pinch or cut the wires on the drive head side.
12. Re-install the three 3mm hex fasteners with appropriate bit (Fig. 13).
13. Re-install the 20mm Torx fastener using appropriate bit (Fig. 7).

## ⚠ CAUTION

**Use caution re-installing the fasteners securing the rear end cap, they can easily be stripped.**

### Install Quality Label

1. Install quality label (Fig. 21) on production label as shown below or at this location near the left hand end cap inside the lead rail profile, if there is no production label present.

Fig. 21



As a supplier of components to the RV industry, safety, education and customer satisfaction are our primary concerns. Should you have any questions, please do not hesitate to contact us at (574) 537-8900 or by email at [customerservice@lci1.com](mailto:customerservice@lci1.com). Self-help tips, technical documents, product videos and a training class schedule are available at [lci1.com](http://lci1.com) or by downloading the MyLCI app.