



Service Bulletin

Bulletin No.: 18-NA-361

Date: October, 2020

TECHNICAL

Subject: Diagnostic Tip for Diesel Fuel System Contamination, Malfunction Indicator Lamp (MIL) Illuminated - DTC P026D, P2A00, P0171, P0172 and/or P0300 Set

Brand:	Model:	Model Year:		VIN:		Engine:	Transmission:
		from	to	from	to		
Chevrolet	Cruze	2014	2015	—	—	2.0L Diesel (LUZ)	—
	Cruze	2018	2019				
	Equinox	2018	2019				
	Silverado	2017	2018				
	Silverado 1500	2020	2021				
	Silverado 2500/3500	2019	2021				
	Silverado 4500HD, 5500HD and 6500HD	2019	2021				
GMC	Sierra	2017	2018	—	—	6.6L V-8 Duramax Turbo Diesel (L5P)	—
	Sierra 1500	2020	2021				
	Sierra 2500/3500	2019	2021				
	Terrain	2018	2019				

Involved Region or Country	North America, Israel
Condition	Some customers may comment that the MIL is illuminated.



5168457

Some technicians may find metal particles in the fuel system during diagnostics.

Important: If the fuel/water filter has been removed for inspection, **Do Not** install the filter back into the housing until the fuel/water separator reservoir has been cleaned. Refer to the Information on Fuel/Water Filter Removal section below.

Some technicians may also find one or more of the following DTCs set in the Engine Control Module (ECM):

- P0171: Fuel System Lean
- P0172: Fuel System Rich
- P026D: Injection Quantity Too High
- P0300: Engine Misfire Detected
- P2A00: HO2S Performance Sensor 1

Correction

If you encounter such a situation, **DO NOT** replace the fuel system as described in Service Bulletin #16-NA-102.

Please perform the following fuel system flushing procedure prior to performing further diagnostics.

Once the fuel system has been flushed, continue with diagnostics as described in SI.

Information on Fuel/Water Filter Removal

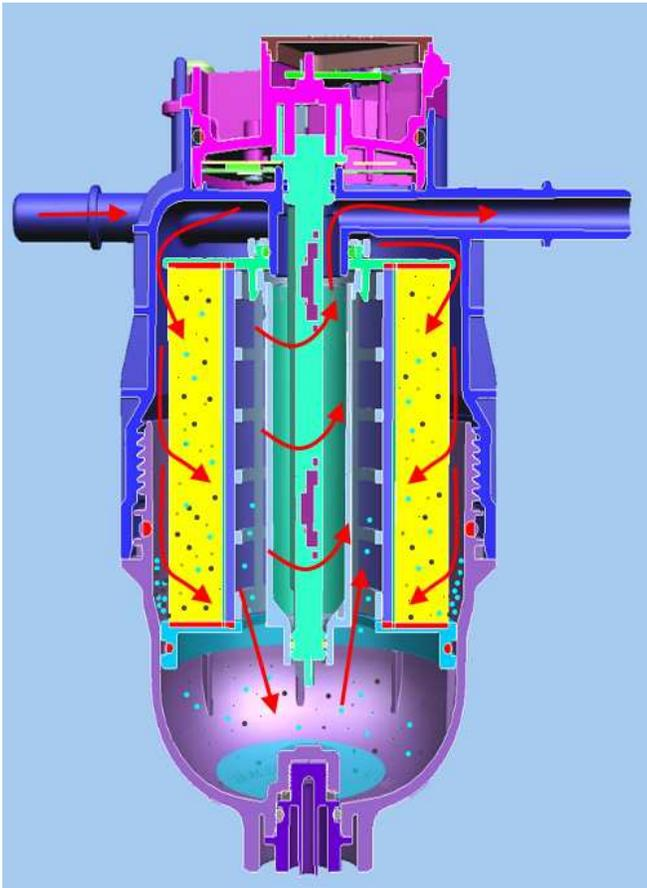

5417311

Water or other like contaminants in the fuel will create driveability concerns and loss of engine power. If water and/or debris is present in the fuel system, the fuel cannot cool and lubricate the components properly, causing overheating, rust and corrosion. This can result in component failure. Water and debris can enter the fuel system in several ways, either through a contaminated refueling source, plugged venting or through long term condensation in the vehicle fuel tanks.

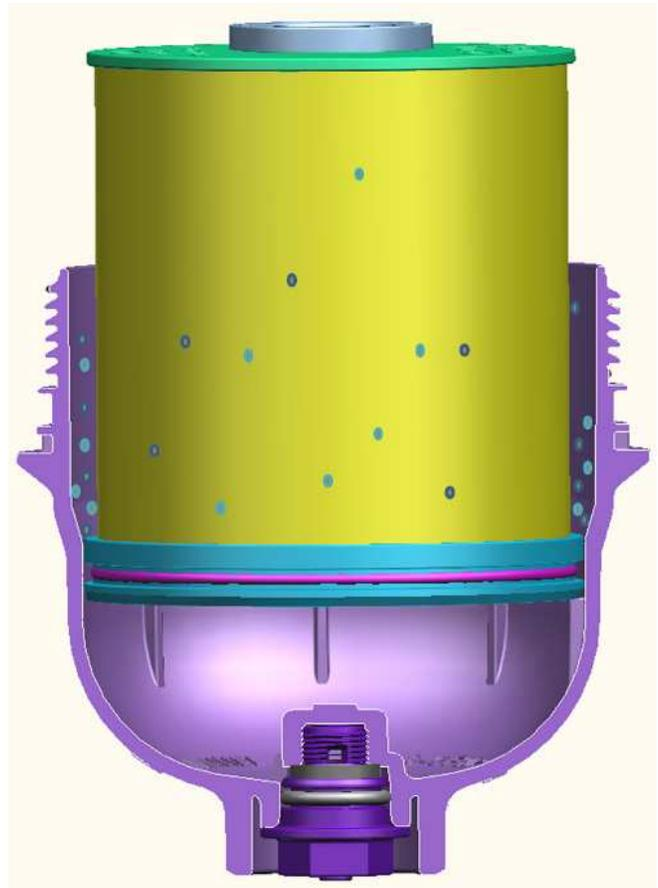

5417281

1. Remove the fuel/water filter from the housing using care not to separate the filter from the fuel/water separator reservoir.

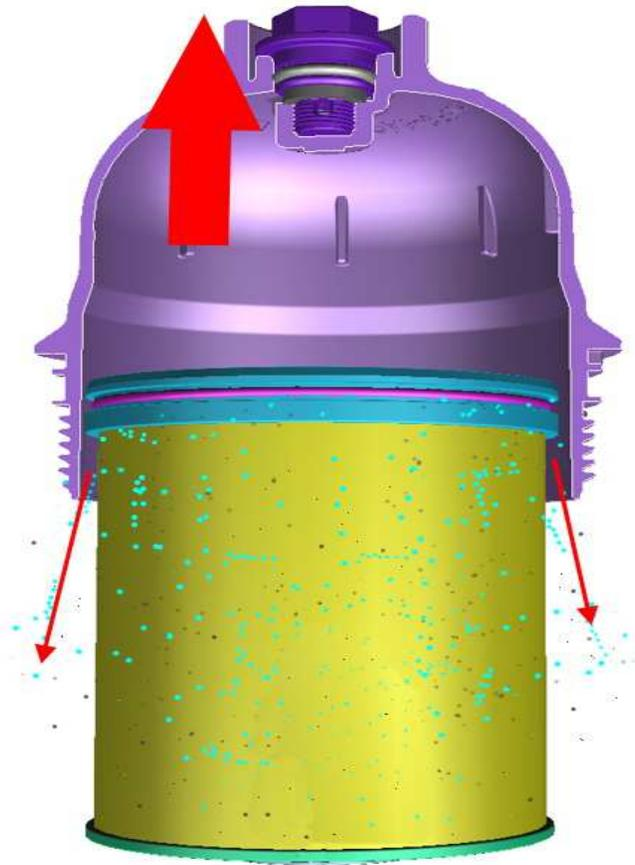

5417298

2. Using care, separate the filter from the fuel/water separator reservoir by placing the filter downwards in a clean/dry drain pan.

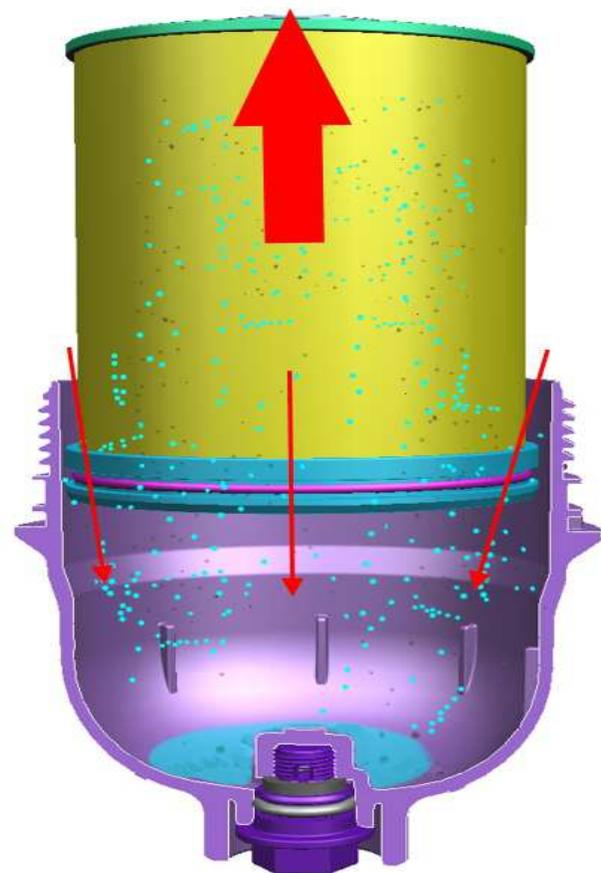

5417283

- If the filter is facing upwards, debris left on the sides of the filter may escape past the O-ring seal during removal and settle in the fuel/water separator reservoir.
 - Water and/or debris left in the fuel/water separator reservoir will flow past the filter, directly into the fuel system when re-started.
 - Debris that is allowed past the filter and into the fuel system can cause fuel injection issues that may set DTCs P2A00, P026D, P0300, P0172. Replacement of fuel injectors without a complete cleaning of the fuel system will only be a temporary fix until the debris gets into the new injectors.
3. Inspect the fuel/water separator reservoir and filter for heavy debris.
 - If heavy debris is found in the filter, clean the fuel/water separator reservoir and continue to the Fuel System Flushing Procedure below.
 - If no signs of debris are found, clean the fuel/water separator reservoir, install a new filter and refer to SI for further diagnostics.

Fuel System Flushing Procedure

Note: Performing the test may aid in determining the source and section of the fuel system causing the contamination.

1. If removed, re-install the fuel filter.

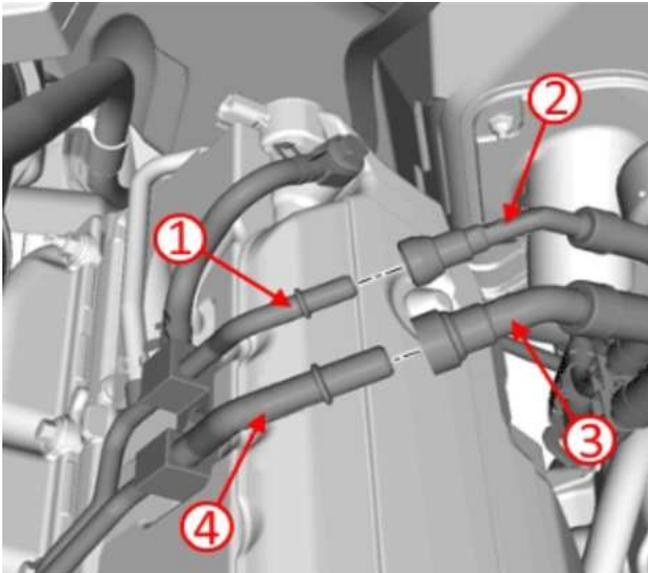

5167517

2. Disconnect the chassis side fuel feed hose (3) from the engine side fuel feed pipe (4).
3. Place the end of the chassis side fuel feed hose into a clean container and run the fuel pump to clean any debris left in the fuel lines, approximately 2-3 gallons (7.6-11.4L).
4. Clean the fuel/water separator reservoir.
5. Install a new fuel filter.
6. Disconnect the chassis side fuel return hose (2) from the engine side return pipe (1).

Note: The white "Tubing" shown in the graphics below depict the route of the clear line, not the length.

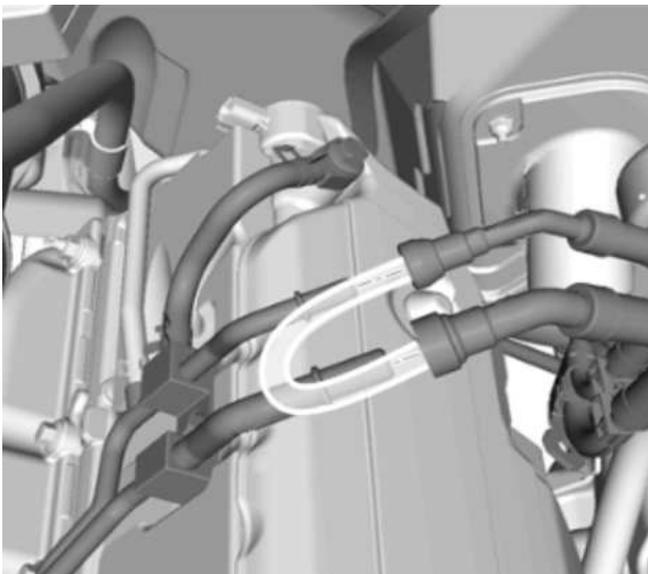

5168476

7. Install a clear line between the fuel supply hose and the fuel return hose.
8. Run the fuel pump until the fuel runs clear in the line.

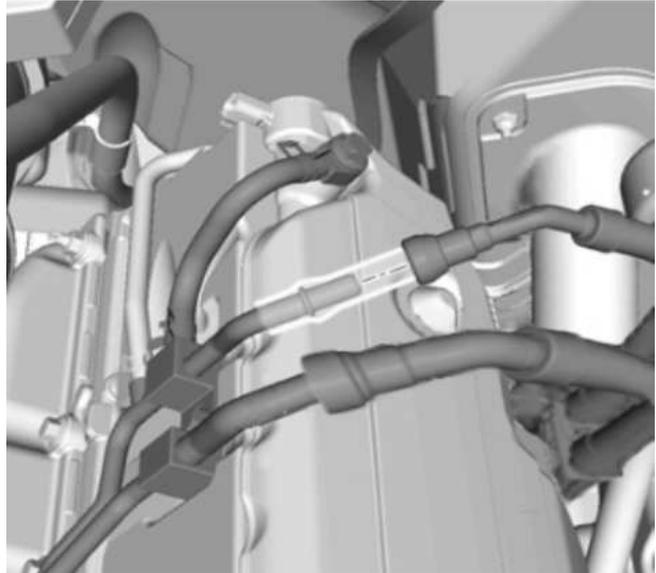

5168447

9. Connect the fuel supply hose to the engine supply pipe.
10. Install a clear line in series at the fuel return hose to the engine return pipe.
11. Run the fuel pump until the fuel runs clear in the line.

Reconnect all fuel lines and retest for any codes or symptoms in the vehicle.

Parts Information

No parts are required for this repair.

Version	7
Modified	Released December 10, 2018 June 24, 2019 – Added 2020 to Model Year. August 14, 2019 – Added 2019 and 2020 Silverado HD Models. October 03, 2019 – Added Information on Fuel/Water Filter Removal section. October 14, 2019 – Removed LCF and added 2020 Silverado/Sierra 1500 with LM2. September 09, 2020 – Added DTCs to the Subject, Condition and Information on Fuel/Water Filter Removal sections. October 20, 2020 – Added the 2021 Model Year to Silverado and Sierra Models and additional engine descriptions.

