

December 18, 2020

Version 1

## Warranty Extension: 2013 ILX Hybrid Motor IMA Motor Power Inverter (MPI)

### AFFECTED VEHICLES

Year	Model	Trim Level	VIN Range
2013	ILX Hybrid	ALL	Check the iN VIN status for eligibility.

### BACKGROUND

The motor power inverter (MPI), also known as the intelligent inverter unit (IIU), may fail over time due to a defective solder joint. This failure may result in one or more of the following DTC(s):

- P1440 (MPI Module Output Circuit Malfunction)
- P1437 (MPI Module Short Circuit)
- P15A5 (Motor Current Sensor Circuit Malfunction)
- P0A78 (MPI Module Internal Circuit Malfunction)
- P0AE1 (Bypass Contractor Malfunction)
- P0A3C (Motor Control Module (MCM) Overheating)
- P0A3F (Motor Rotor Position Sensor Circuit Malfunction)
- P0DA8 (MPI Module Voltage Malfunction)
- P1634 (MPI Module Signal Circuit Malfunction)
- P0AEE (MPI Internal Circuit Malfunction)
- P0A27 (High Voltage Contactor Stays Activated)

American Honda is extending the warranty coverage of the motor power inverter (MPI) on these vehicles to 15 years from the original date of purchase or 150,000 miles, whichever comes first.

### CLIENT NOTIFICATION

Owners of affected vehicles will be sent a notification of this campaign.  
Do an iN VIN status inquiry to make sure the vehicle is shown as eligible.

### CORRECTIVE ACTION

Do an all-DTC check and replace the MPI if any of the DTC(s) listed under INSPECTION PROCEDURE are stored.

**CLIENT INFORMATION:** The information in this bulletin is intended for use only by skilled technicians who have the proper tools, equipment, and training to correctly and safely maintain your vehicle. These procedures should not be attempted by "do-it-yourselfers," and you should not assume this bulletin applies to your vehicle, or that your vehicle has the condition described. To determine whether this information applies, contact an authorized Acura automobile dealer.

## PARTS INFORMATION

Part Name	Part Number	Quantity
Intelligent Inverter Unit (IIU) (Motor Power Inverter [MPI])	061B0-RW0-A00	1

## TOOL INFORMATION

Tool Name	Tool Number	Quantity
Insulated Tool Kit	OTCHON5999	1

## WARRANTY CLAIM INFORMATION

Operation Number	Description	Flat Rate Time	Defect Code	Symptom Code	Template ID	Failed Part Number
1181EH	Do an all-DTC check, and replace the MPI. (Includes clearing DTCs.)	1.5 hr	6Y800	B9700	B20021A	1B200-RW0-000

Skill Level: Repair Technician

## INSPECTION PROCEDURE

1. Connect an i-HDS, and do an ALL DTC check.

*Are any of these DTCs listed?*

- P1440
- P1437
- P15A5
- P0A78
- P0AE1
- P0A3C
- P0A3F
- P0DA8
- P1634
- P0AEE
- P0A27

**Yes** – Replace the MPI unit. Go to REPAIR PROCEDURE.

**No** - This service bulletin does not apply, continue with normal system troubleshooting.

## REPAIR PROCEDURE

### ⚠ WARNING

The IMA motor power cables carry high voltage when the engine is running or the IMA system is energized. To avoid serious injury from electrical shock, do not start the engine with the IMA motor power cables disconnected.

### NOTE

This repair procedure contains the removal of the IMA PCU. The IMA is a high-voltage system. You must be familiar with the IMA system before working on or around it. Make sure you have read the *IMA System Service Precautions* before doing repairs or service.

1. Disconnect the negative and positive 12-volt battery terminals.

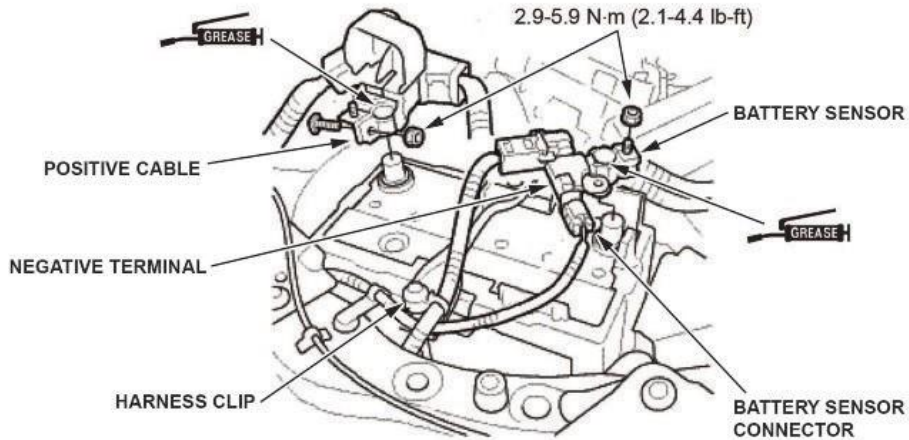

2. Remove the rear seat cushion bolt.

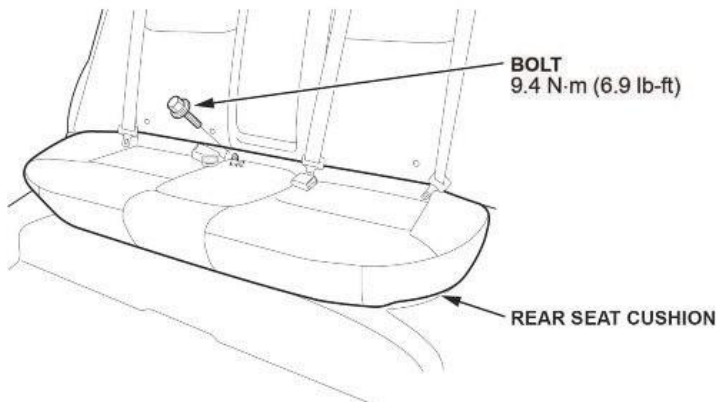

3. Push down on the rear seat cushion, pull out the seat hook handles to release the hooks, and remove the rear seat cushion.

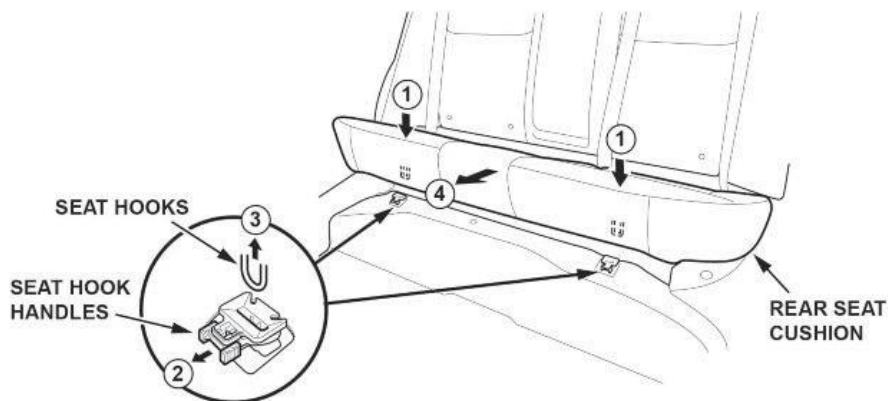

4. Remove the rear seat side bolster bolt.

**NOTE**

The left side is shown; repeat the step on the right side.

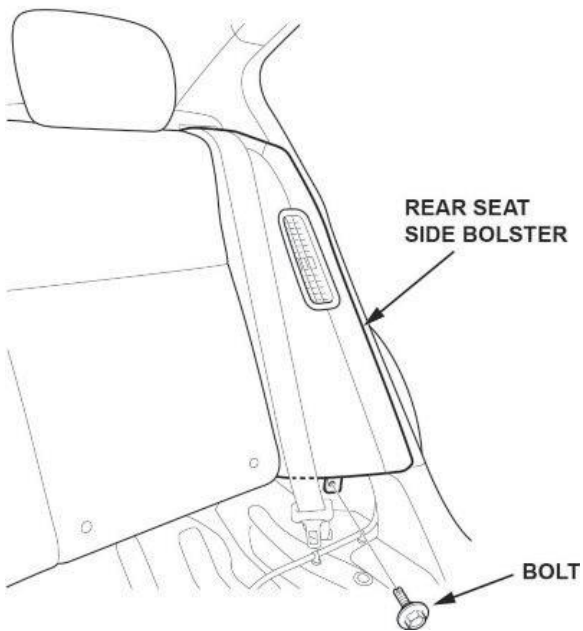

5. Remove the rear seat side bolster.

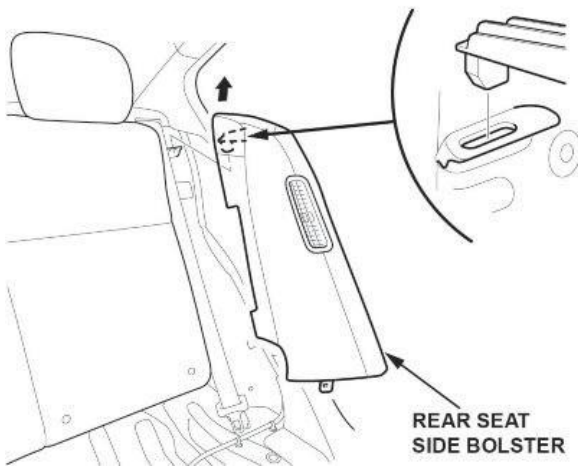

6. Remove all of the rear head restraints.
7. Release the rear center seat belt from the guide.

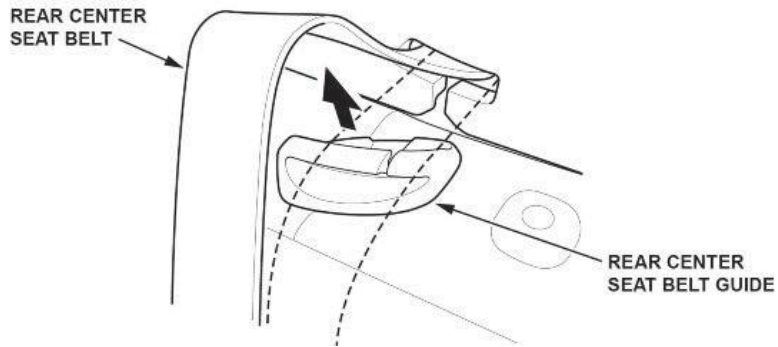

8. Remove the rear seat back bolts.

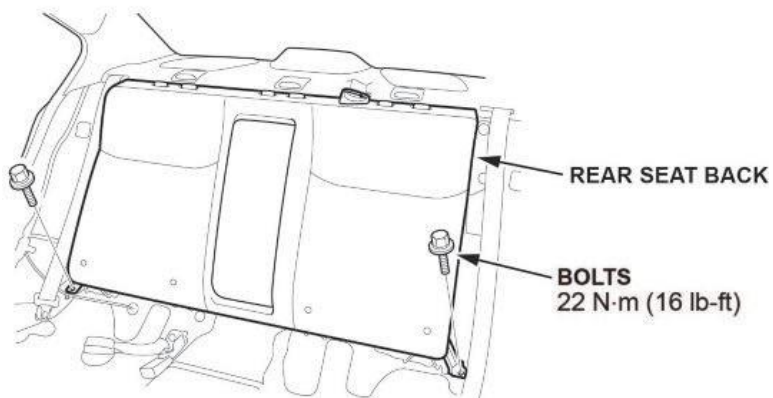

9. Lift the rear seat-back to release the wire loops with collars from the brackets.

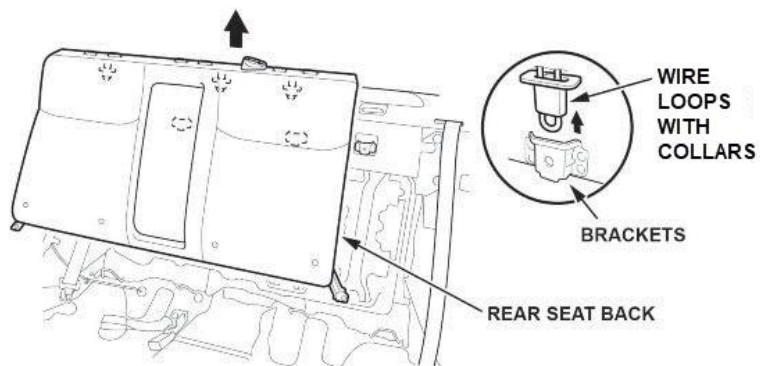

10. Remove the battery module switch lid.

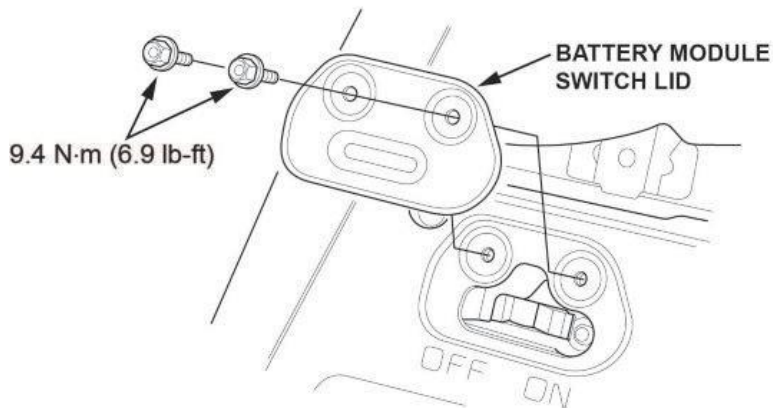

11. Turn the battery module switch to OFF, make sure you can see the bolt, then wait at least **5 minutes** to let the PDU capacitors discharge.

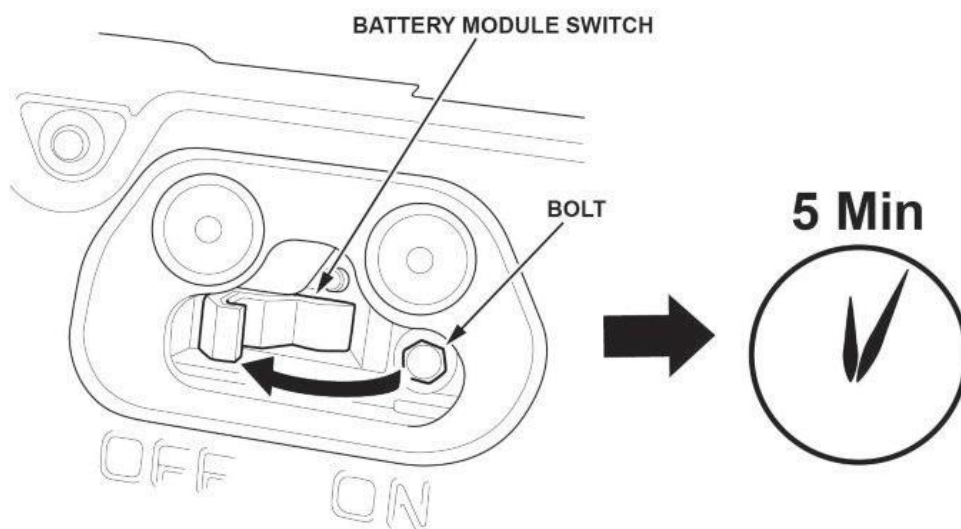

12. Remove the IPU cover.

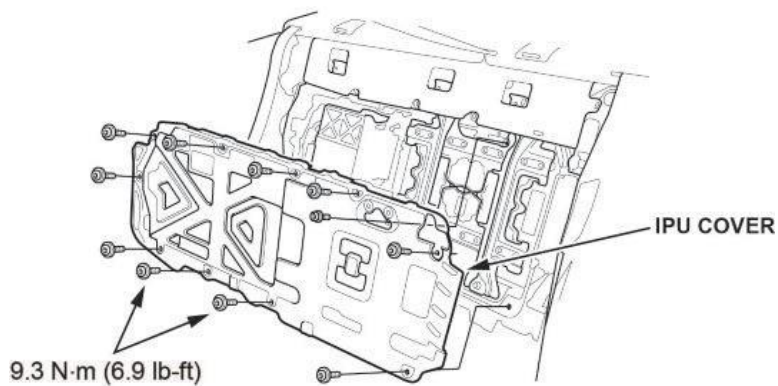

13. Remove the power cable terminal cover.

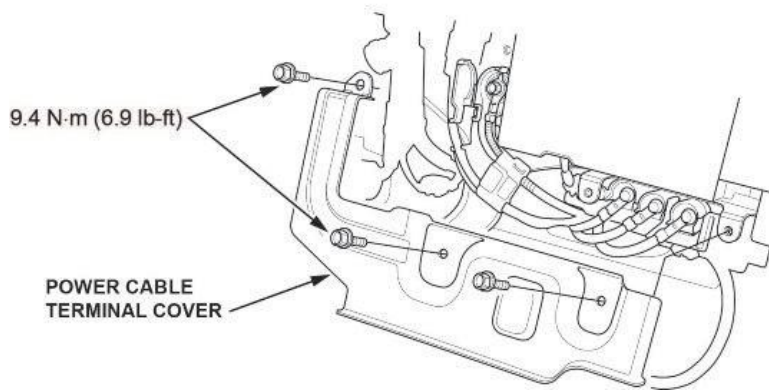

14. Disconnect the connector, then the four cables from the DC-DC converter, and wrap the end of the cables with insulating tape.

**NOTE**

Check the position of the U, V, and W phase cables and label them before disconnecting them.

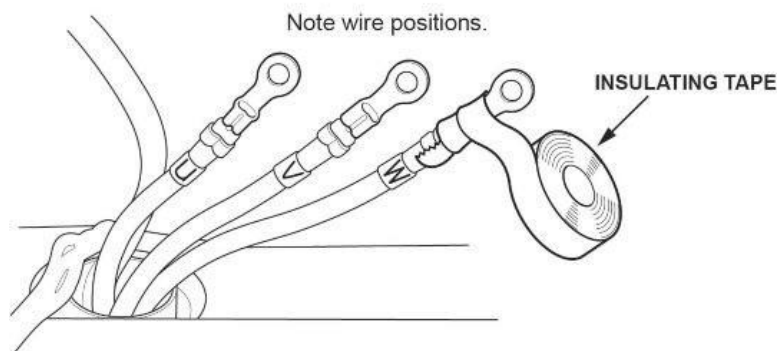
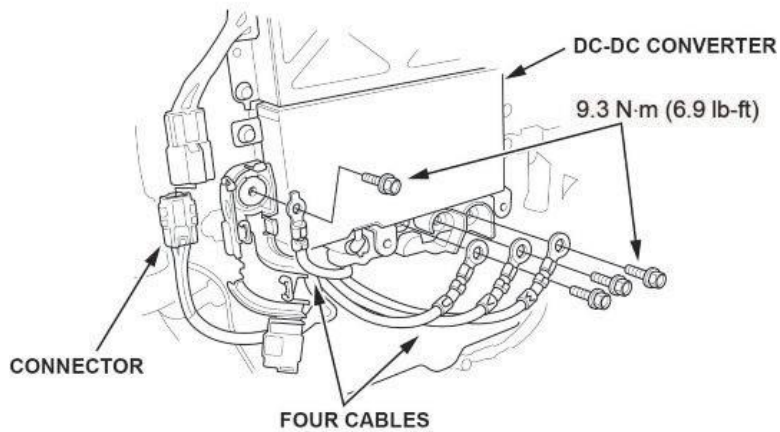

15. Remove the clip, ground cable, cables, and connectors from the PCU as shown.

**NOTE**

Use insulated tools for this procedure.

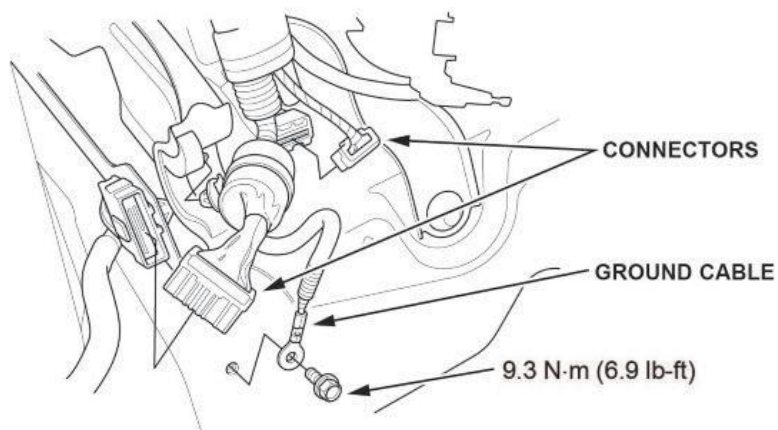
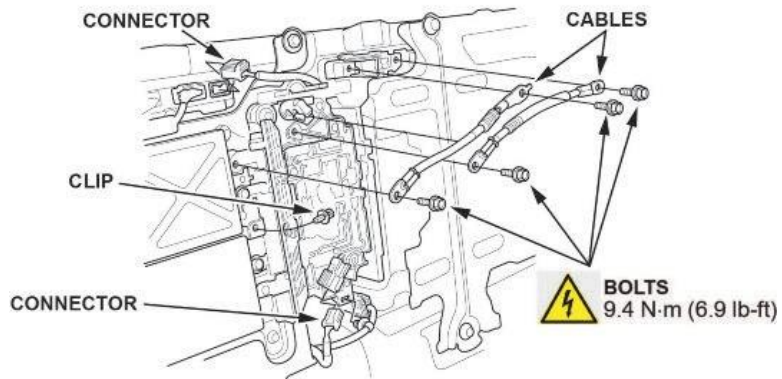

16. Remove the PCU assembly.

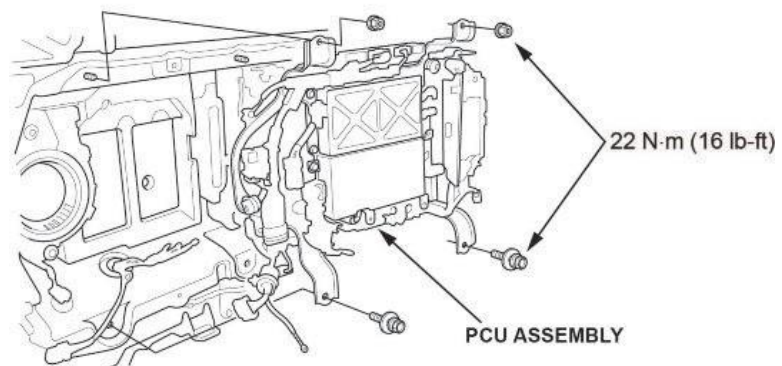



17. Remove the junction board assembly .

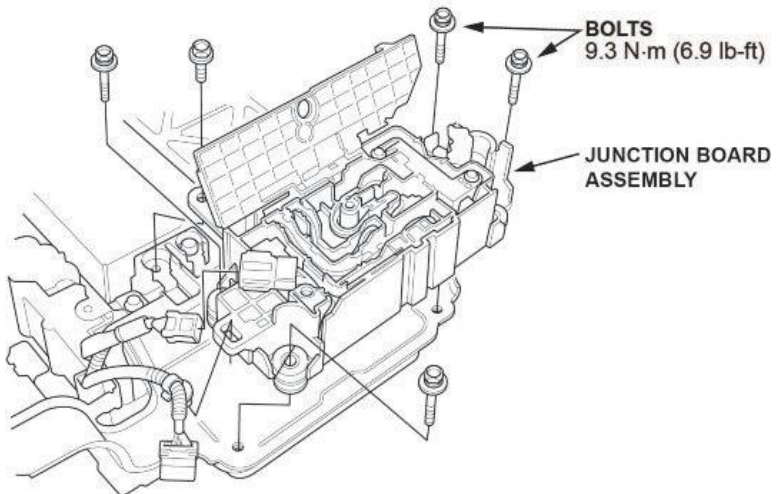

18. Remove the bolts and clips.

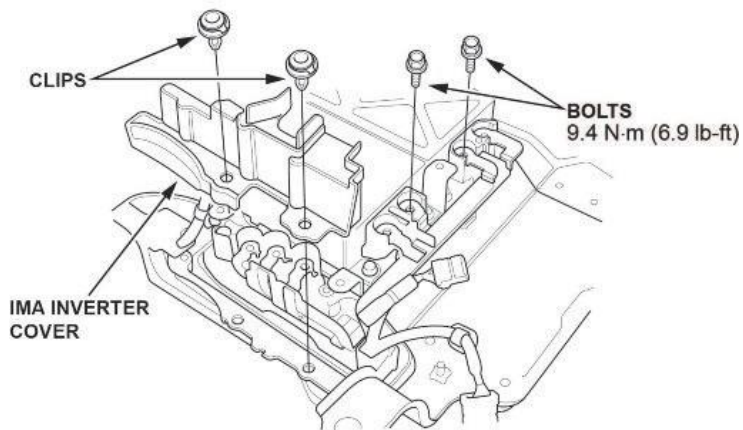

19. Remove disconnect the connectors, then remove the IMA inverter cover.

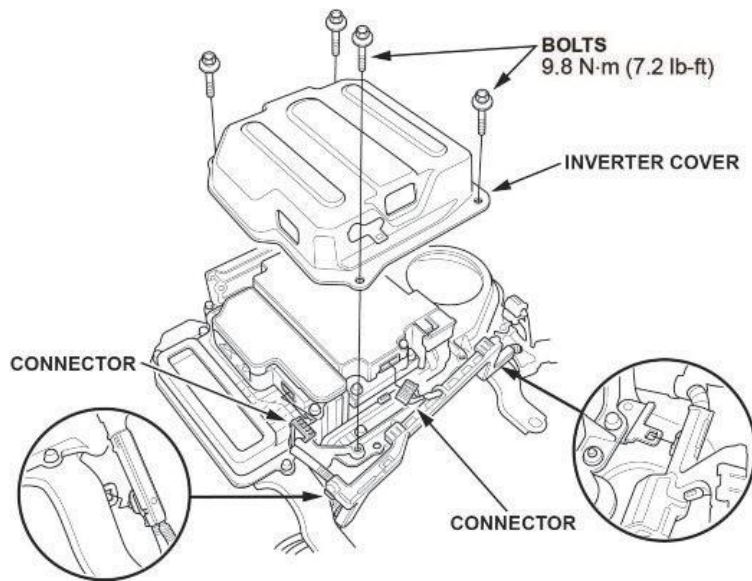

20. Remove the cover, then remove the IMA inverter busbars

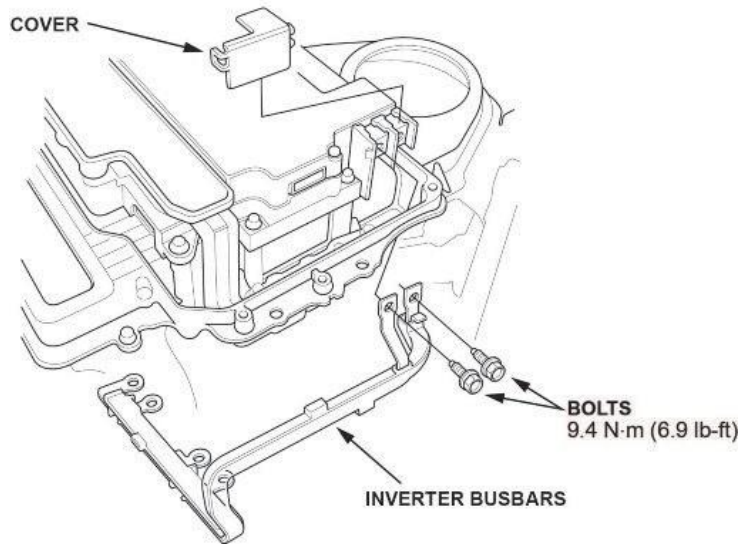

21. Remove the insulator, then remove the busbars.

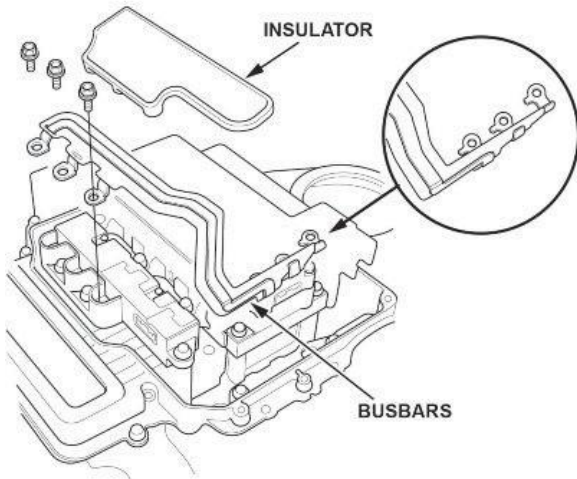

22. Remove the phase motor current sensor and the U, V, and W busbars.

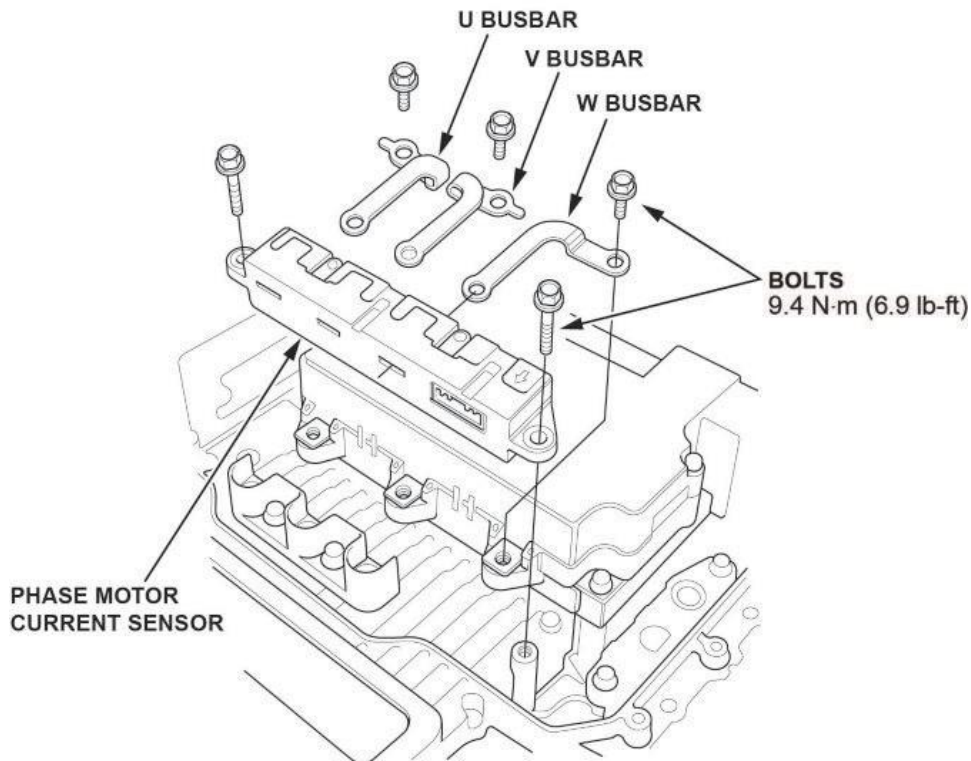

23. Remove the MPI module and install the new MPI module.

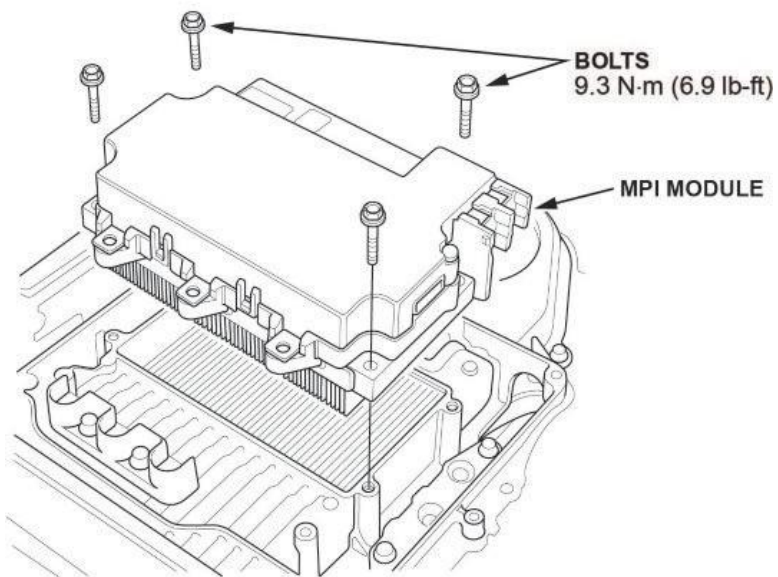

24. Install all removed parts in the reverse order of removal.

25. Clear all DTCs.

END