

# Special Parts Collection – USA

## Code: 69BD



Audi

**REVISION**

<b>Subject</b>	<b>Special Parts Collection – Head Curtain Airbag</b>										
<b>Release Date</b>	December 19, 2020										
<b>REVISION SUMMARY</b>	<b>Updated GFF labor operation</b>										
<b>Affected Vehicles</b>	<table border="1"> <thead> <tr> <th>Country</th> <th>Beginning Model Year</th> <th>Ending Model Year</th> <th>Vehicle</th> <th>Vehicle Count</th> </tr> </thead> <tbody> <tr> <td>USA</td> <td>2016</td> <td>2016</td> <td>Q5</td> <td>273</td> </tr> </tbody> </table> <p><i>Check Campaigns/Actions screen in Elsa on the day of repair to verify that a VIN qualifies for repair under this action. Elsa is the <u>only</u> valid campaign inquiry &amp; verification source.</i></p> <ul style="list-style-type: none"> <li>✓ Campaign status must show “open.”</li> <li>✓ If Elsa shows other open action(s), inform your customer so that the work can also be completed at the same time the vehicle is in the workshop for this campaign.</li> </ul>	Country	Beginning Model Year	Ending Model Year	Vehicle	Vehicle Count	USA	2016	2016	Q5	273
Country	Beginning Model Year	Ending Model Year	Vehicle	Vehicle Count							
USA	2016	2016	Q5	273							
<b>69BD Special Parts Collection Program</b>	<p>Audi is conducting a special parts collection program involving the head curtain airbags from selected 2016 model year Audi Q5 vehicles.</p> <p>Under this program:</p> <ul style="list-style-type: none"> <li>• All eligible vehicles showed the Special Parts Collection code 69BD in ELSA on December 04, 2020.</li> <li>• Owner notification will take place in December 2020 via first-class mail.</li> <li>• Only vehicles registered &amp; located within the 48-contiguous United States may participate.</li> <li>• The head curtain airbags will be replaced free of charge by an authorized Audi dealer.</li> <li>• Time is of the essence. Once the required number of head curtain air bags have been collected, the program will end and no further replacements will be made.</li> <li>• Return of removed head curtain air bags is <b>mandatory</b>. Claims are subject to cancellation if removed air bags are not returned or if they are improperly returned.</li> </ul>										
<b>Additional Information</b>	<b>Please alert everyone in your dealership about this action, including Sales, Service, Parts and Accounting personnel. Contact Warranty if you have any questions.</b>										

## Parts Information

<b>Parts Control Type:</b> <b>Free Order</b>	Parts will be managed by Free Order
---	-------------------------------------

<b>Initial Allocation:</b> <b>NO</b>	Due to the small number of affected vehicles there will be no parts allocation. Please reference the Repair Projection Tool (below) to view your potential VIN population.
---	--

<b>Repair Projection Tool:</b> <b>(right click to open)</b>	
--	---

Criteria	Quantity	Part Number	P.O.C. Part Description	Ordering Method
01	1	8R0-880-742-L	Airbag (Right)	Free Order
	1	N -912-259-01	Bolt	Free Order
02	1	8R0-880-741-L	Airbag (Left)	Free Order
	1	N -912-259-01	Bolt	Free Order

### NOTE

The specified part numbers reflect the status at the start of this action. Interim updates made in ETKA can cause a listed part number to become unavailable. In this case, the new part number specified in ETKA should be used.

### NOTE

A supply of parts dedicated to this special program was sent to all PDCs prior to owner notification.

Removed head curtain air bags must be returned to the designated inspection facility. **These MUST be returned in their as removed from vehicle condition.**

Requests for removed air bags will be available in the Warranty Parts Portal (WPP) once the claim has reached approved status in SAGA. Use the Warranty Parts Portal to obtain the FedEx shipping label and required hazardous material documentation.

## Claim Entry Instructions

The labor times listed here may differ from the labor operations and labor times listed in ELSA.

After campaign has been completed, enter claim as soon as possible to help prevent work from being duplicated elsewhere. Attach the Elsa screen print showing action open on the day of repair to the repair order.

If customer refused campaign work:

- ✓ U.S. dealers: Submit the request through Audi Warranty Online under the Campaigns/Update option.

<b>Service Number</b>	69BD
<b>Damage Code</b>	0099
<b>Parts Vendor Code</b>	002
<b>Claim Type</b>	Sold vehicle: 7 10 Unsold vehicle: 7 90
<b>Causal Indicator</b>	<p><u>Vehicles assigned only one criteria:</u> Mark airbag* as causal part</p> <hr/> <p><u>Vehicles assigned criteria 01 <b>and</b> 02:</u>  <span style="color: red;"><b>Due to the special circumstance of this project two claims are required. A claim must be entered for each criteria for vehicles assigned criteria 01 <u>and</u> 02</b></span>            Criteria I.D. 01 – mark right head curtain airbag* as causal part            Criteria I.D. 02 – mark left head curtain airbag* as causal part  <i>NOTE: Due to the overlap in work steps, the labor for the second head curtain airbag will be claimed at 10 TU.</i></p>
<b>Vehicle Wash/Loaner</b>	Do not claim wash/loaner under this action

### Vehicles Assigned Criteria 01 ONLY

Criteria I.D.	01		
	<b>LABOR</b>		
	<b>Labor Op</b>	<b>Time Units</b>	<b>Description</b>
	6966 55 99	440	Replace <u>right</u> head curtain airbag
	0150 00 00	Time stated on diagnostic protocol	Clear repair related faults
	<b>PARTS</b>		
	<b>Quantity</b>	<b>Part Number</b>	<b>Description</b>
	1.00	8R0880742L	Airbag (right)*
	1.00	N 91225901	Bolt

## Vehicles Assigned Criteria 02 ONLY

Criteria I.D.	02		
	<b>LABOR</b>		
	Labor Op	Time Units	Description
	6966 56 99	440	Replace <u>left</u> head curtain airbag
	0150 00 00	Time stated on diagnostic protocol	Clear repair related faults
	<b>PARTS</b>		
	Quantity	Part Number	Description
	1.00	8R0880741L	Airbag (left)*
	1.00	N 91225901	Bolt

## Vehicles Assigned Criteria 01 and 02 (two claims required)

Criteria I.D.	01		
<b>1<sup>st</sup> Claim</b>	<b>LABOR</b>		
	Labor Op	Time Units	Description
	6966 57 99	440	Replace <u>right</u> head curtain airbag
	0150 00 00	Time stated on diagnostic protocol	Clear repair related faults
	<b>PARTS</b>		
	Quantity	Part Number	Description
	1.00	8R0880742L	Airbag (right)*
	1.00	N 91225901	Bolt
Criteria I.D.	02		
<b>2<sup>nd</sup> Claim</b>	<b>LABOR</b>		
	Labor Op	Time Units	Description
	6966 58 99	10	Replace <u>left</u> head curtain airbag
	<b>PARTS</b>		
	Quantity	Part Number	Description
	1.00	8R0880741L	Airbag (left)*
1.00	N 91225901	Bolt	

The repair information in this document is intended for use only by skilled technicians who have the proper tools, equipment and training to correctly and safely maintain your vehicle. These procedures are not intended to be attempted by "do-it-yourselfers," and you should not assume this document applies to your vehicle, or that your vehicle has the condition described. To determine whether this information applies, contact an authorized Audi dealer. ©2020 Audi of America, Inc. and Audi Canada. All Rights Reserved.

## Customer Letter Example (USA)

<MONTH YEAR>

<CUSTOMER NAME>

<CUSTOMER ADDRESS>

<CUSTOMER CITY STATE ZIPCODE>

**This notice applies to your vehicle:** <MODEL YEAR> <BRAND> <CARLINE>, <VIN>

**Subject: Special Parts Collection 69BD – Head Curtain Air Bags**

Dear Audi Owner,

Audi is conducting a special head curtain air bag collection program. Your vehicle has been selected to participate in this program.

**This is not a recall. As explained below, we are doing this as part of a safety & quality assurance initiative.**

### **SPECIAL PARTS COLLECTION PROGRAM**

- Audi has pre-selected your vehicle to analyze the head curtain air bags. Under this program, we would like to replace one or both of these head curtain air bags in your vehicle with new parts **FREE** of charge.
- Only vehicles registered/located within the 48-contiguous United States are eligible for this program.

### **HOW TO PARTICIPATE – WHAT YOU CAN DO**

- If you would like to participate in this program, please contact an authorized Audi dealer at your earliest convenience. For your convenience, you can also visit [www.audiusa.com](http://www.audiusa.com) and click on the “Find a Dealer” link to locate a dealer near you and schedule this service.
- Head curtain air bag replacement may take up to a day to complete. Please keep in mind that your dealer may need additional time for the preparation of the replacement, as well as to accommodate their daily workshop schedule.

If you should have any questions about this communication, please contact Audi Customer Experience at 1-800-253-2834 or via our “Contact Us” page at [www.audiusa.com](http://www.audiusa.com).

Sincerely,

Audi Customer Protection

*Time is of the essence. Audi has a specific number of head curtain air bags to collect under this program. Once this goal is reached, the program will end and no more replacements will be made.*

## Repair Overview

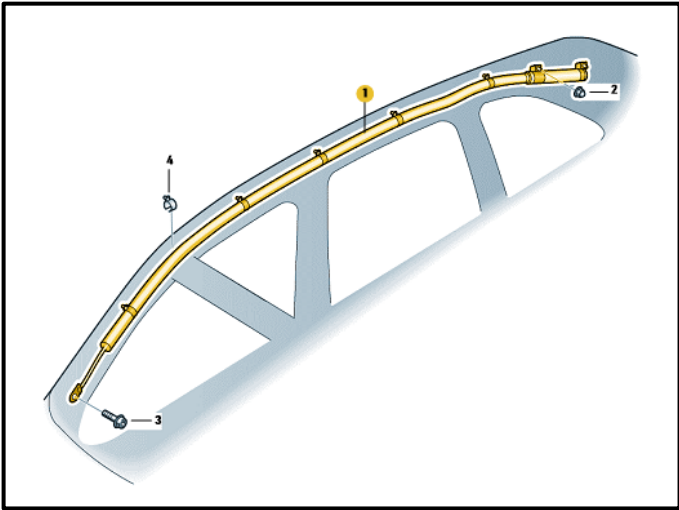



- Replace left and/or right head curtain airbag.
  - Criteria 01 = right
  - Criteria 02 = left

### NOTE

- These repair instructions may differ from the labor operations and labor times listed in ELSA.
- Damages resulting from improper repair or failure to follow these work instructions are the dealer's responsibility and are not eligible for reimbursement under this action.
- This procedure must be read in its entirety prior to performing the repair.
- Due to variations in vehicle equipment and options, the steps/illustrations in this work procedure may not identically match all affected vehicles.
- Diagnosis and repair of pre-existing conditions in the vehicle are not covered under this action.
- When working during extreme temperatures, it is recommended that the vehicle be allowed to acclimate inside the shop to avoid temperature-related component damage/breakage.

## Required Tools

	<p>Pry lever -80-200- (or equivalent)</p>		<p>Omega Clip Tool -T40280- (or equivalent)</p>
	<p>Trim Removal Wedge -3409- (or equivalent)</p>		<p>Angled Screwdriver -VAS6416- (or equivalent)</p>
	<p>Clip pliers -VAS211001- (or equivalent)</p>		<p>Removal Wedge -T40233- (or equivalent)</p>

## Repair Instruction

### Section A - Check for Previous Repair

Applicable criteria ID(s)	Campaign/Action Status
01 ← 2	Open ← 1

**EXAMPLE**

Campaign/Action	Start	Designation
→ 3	2015-11-10	W-SERV_ACT -
	2018-12-13	RECALL -
	2017-05-16	A-RECALL -

**EXAMPLE**

- Enter the VIN in Elsa and proceed to the “Campaign/Action” screen.

#### TIP

On the date of repair, print this screen and keep a copy with the repair order.

- Confirm the Campaign/Action is open <arrow 1>. If the status is closed, no further work is required.
- Note the Applicable Criteria ID <arrow 2> for use in determining the correct work to be done and corresponding parts associated.

#### CRITICAL REPAIR STEP

 **STOP!** 

If multiple software update Campaign/Actions are open, they must be performed in order of the Start date <arrow 3>. The oldest should be performed first.

- **All Safety Recalls must be completed prior to completing this campaign.**
- **Proceed to Section B.**



## Section B – Repair Procedure

### WARNING

Risk of injury. Refer to “Warning and Safety Precautions”, found in **Appendix A** at the end of this document.

### NOTE

The procedures shown for head curtain airbag replacement illustrate the driver side. Repeat the steps for removal and installation of trim panels for the passenger side.

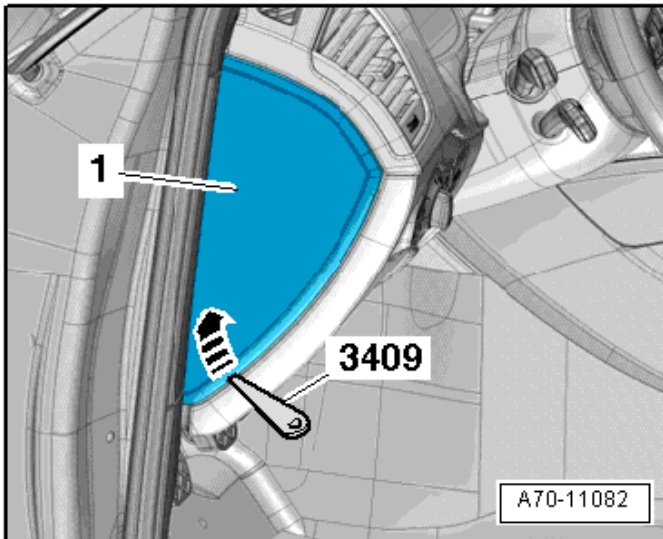

- Fold the backrests forward.
- Recline front seats to a 45° angle.

#### Remove instrument panel side covers:

- Pry the instrument panel side cover <1> off using the -3409- <arrow> and remove it.

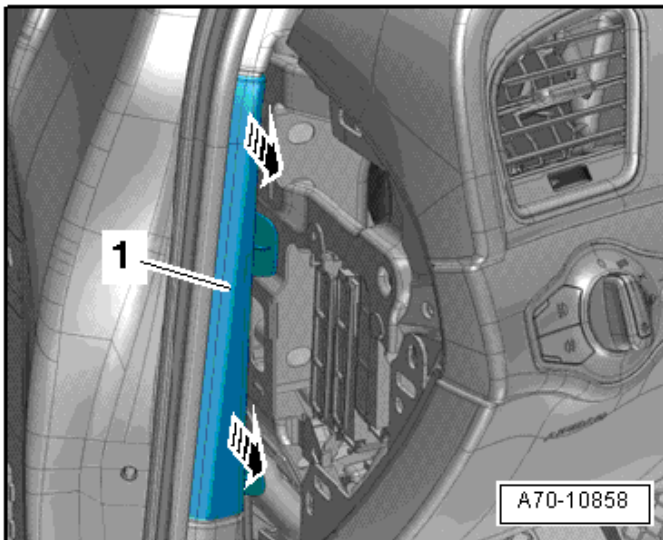

#### Remove gap covers:

- Remove the gap cover <1> from the A-pillar trim and the sill trim <arrow>.
- Remove the gap cover upward from the clips on the A-pillar.

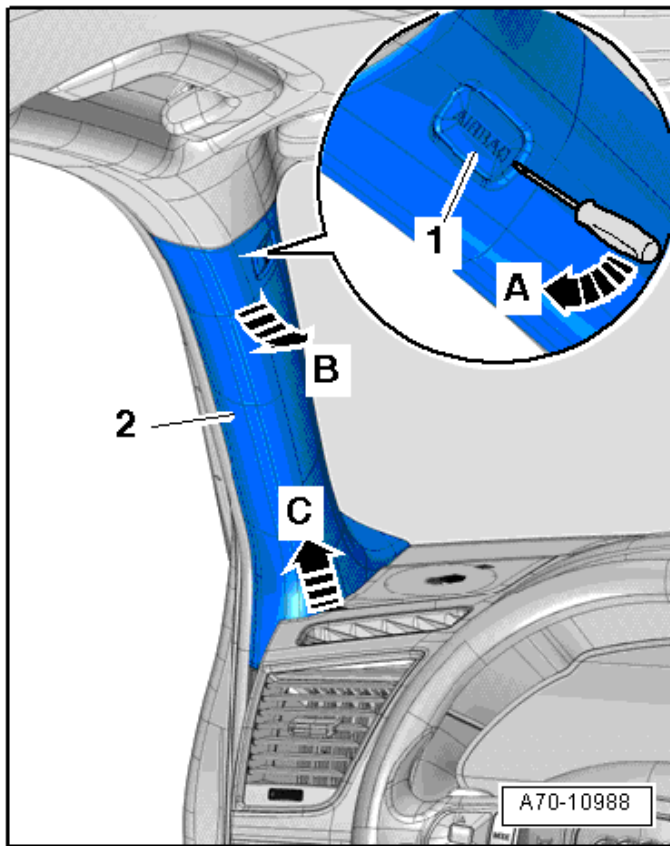

### Remove A-pillar trim:

- Pry out the expanding cap <1> with the “airbag” symbol about 5 mm with a screwdriver <arrow A>.
- The trim is removed from the A-pillar in direction of <arrow B> in different ways depending on which clips are installed in the vehicle.
- If clips with a hook are installed, the trim needs to be pulled just a few millimeters until the hooks engage.
- The clips will then be removed from the A-pillar when the trim is pulled upward in direction of <arrow C>.
- Carefully unclip the A-pillar trim <2> beginning at the top using a -80-200- <arrow B>.
- Push the A-pillar trim upward and remove it <arrow C>.
- Replace damaged clips.

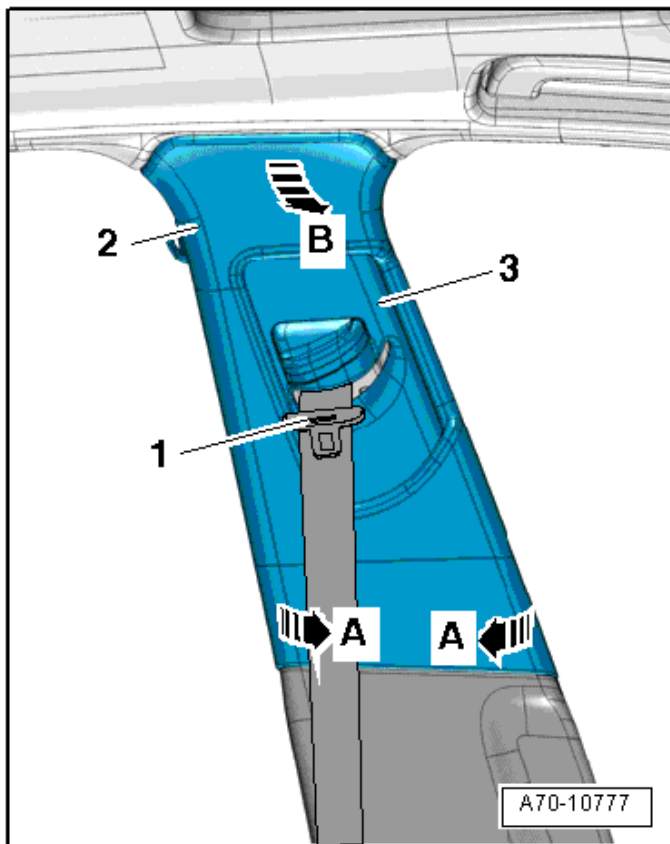

### Remove upper B-pillar trim:

- Press belt height adjuster button and bring height adjuster slide into lowest position.
- Unclip the upper B-pillar trim <2> in direction of <arrows A> by inserting the -3409- into the lower edge of the trim.
- Remove the upper B-pillar trim from the bracket on the body in direction of <arrow B> by moving the trim toward the inside and pulling it downward at the same time.
- Lower the upper B-pillar trim down in the passenger compartment and protect it from damage.

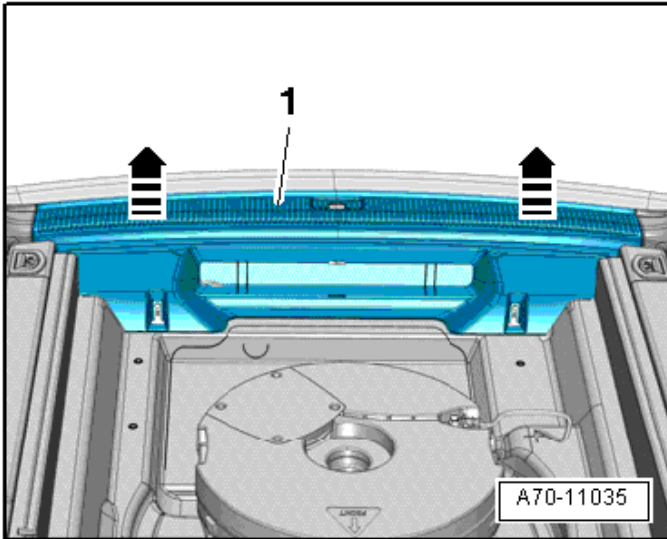

#### Remove lock carrier trim:

- Remove the rear luggage compartment floor.
- Unclip the rear lid end trim panel <1> using the -80-200- diagonally upward in direction of <arrows>.
- Carefully remove the rear lid end trim panel upward and disconnect the connector for the rear lid closed sensor Rear Lid -Closed- Sensor 1 -G525-/Rear Lid -Closed- Sensor 2 - G526-.

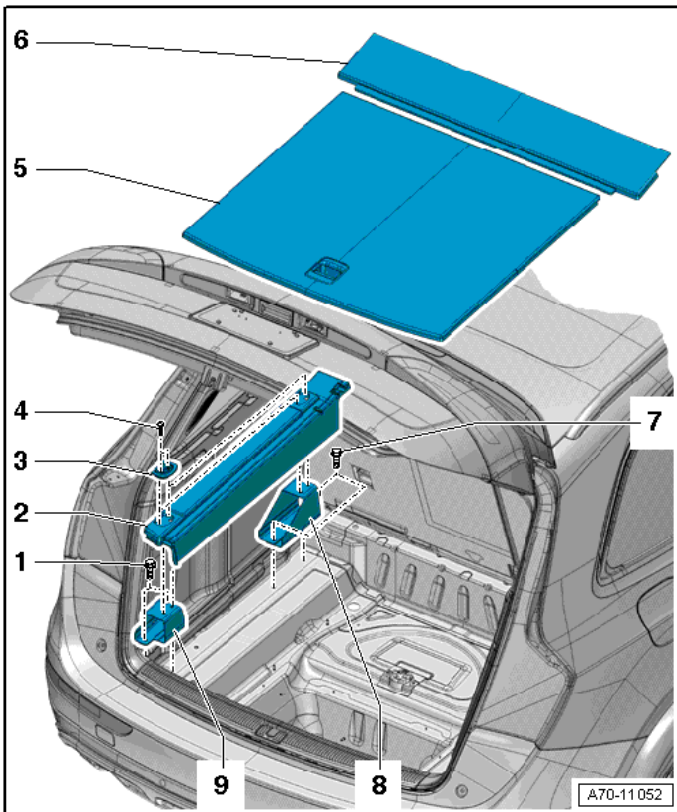

#### Remove gap cover:

- Remove bolts <4>.
- Remove tie downs <3>.
- Remove gap cover <2>.

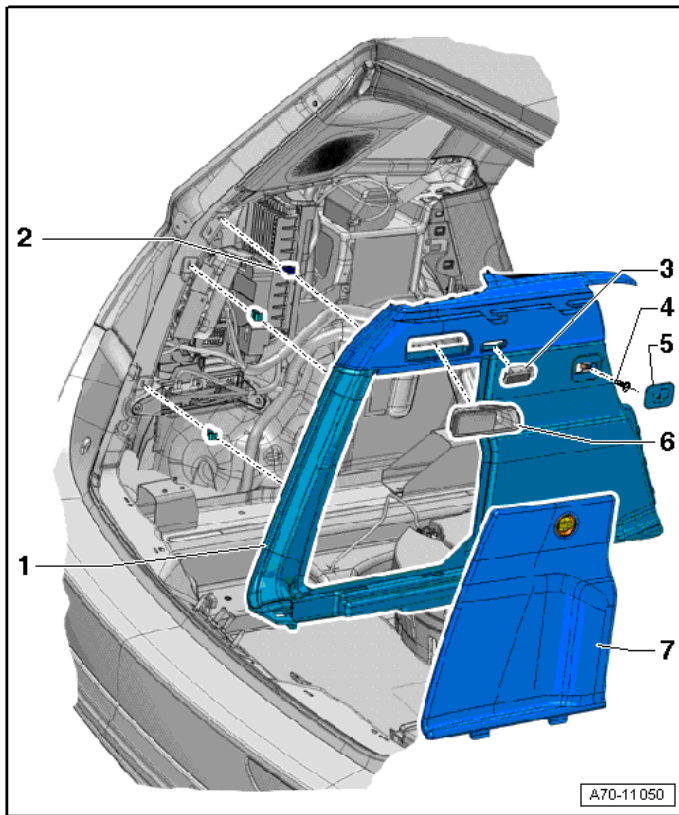

### Remove luggage compartment side panel:

- Remove backrest release <6>.
  - Hold the release lever pulled and remove the screw behind the lever.
  - Unclip the cable from the lever.
- Pry out luggage compartment lamp <3> with the -3409- and disconnect it.
- Pry off coat hook <5> with the -3409-.
- Remove bolt <4>.
- Pry the luggage compartment trim away from the body using the -80-200-.

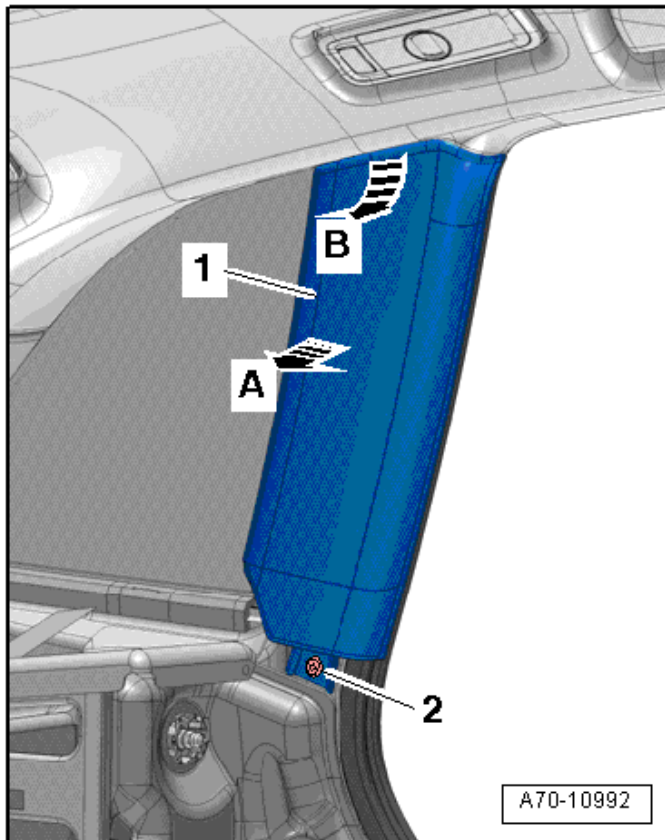

### Remove C-pillar trim:

- Remove the expanding clip <2>.
- Unclip the C-pillar trim panel <1> using the -80-200- in direction of <arrow A>.
- Pull the C-pillar trim downward in direction of <arrow B> and remove.

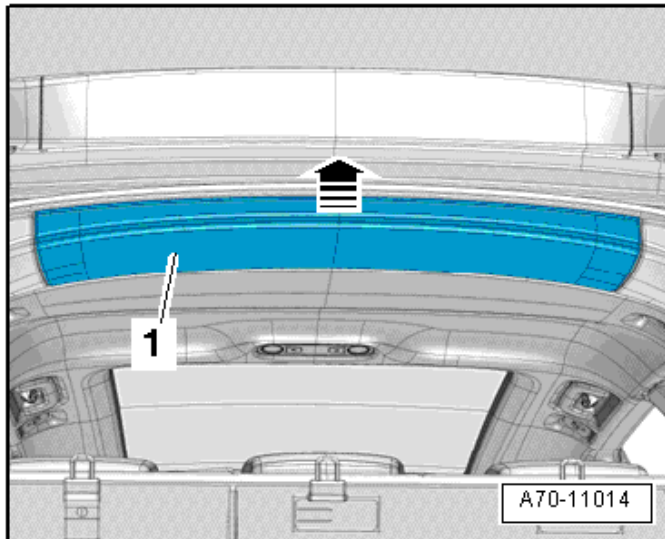

### Remove roof end panel trim:

- Carefully unclip the rear roof panel trim <1> in the center off the roof frame using the -80-200- in direction of <arrow>.

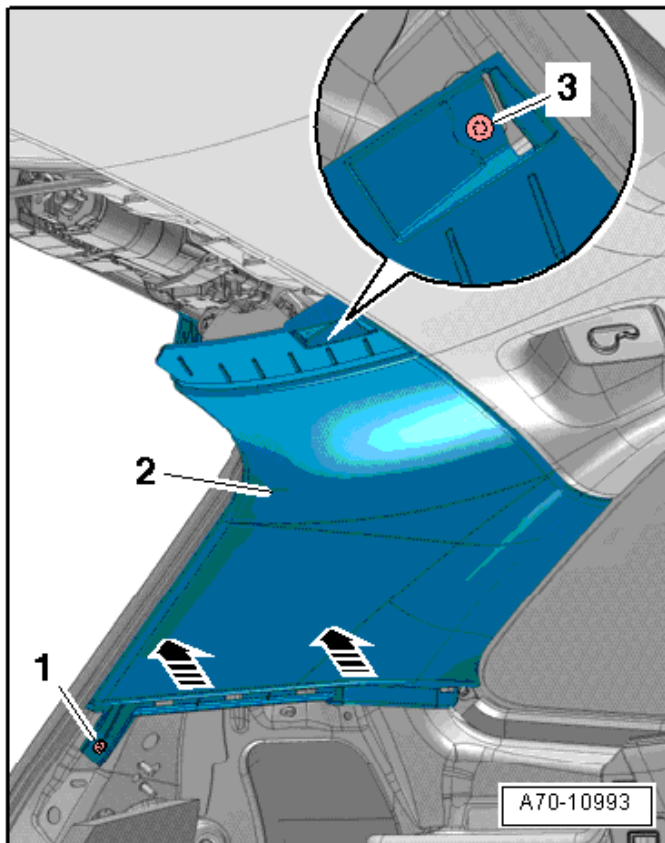

### Remove D-pillar trim:

- Remove the expanding clips <1> and <3>.
- Remove the D-pillar trim <2> from the body <arrows> using the -80-200-.
- Versions with a speaker: Disconnect the connector.

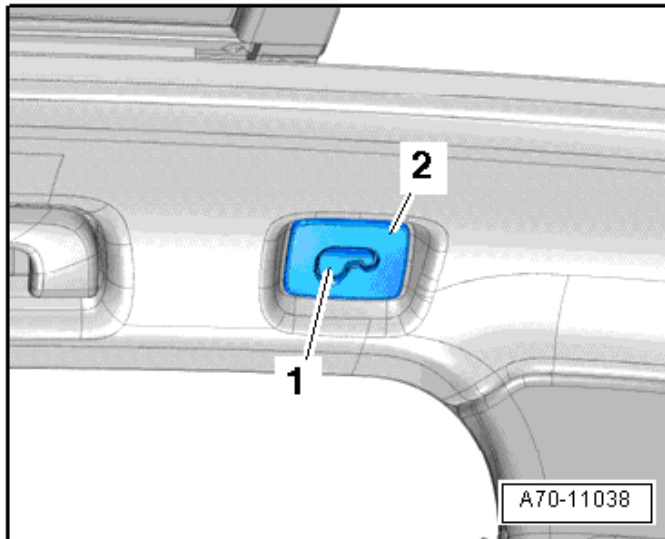

#### Remove screen separator mounts:

- Press the cover <1> toward the inside and remove the screws on the screen separator mount <2>.

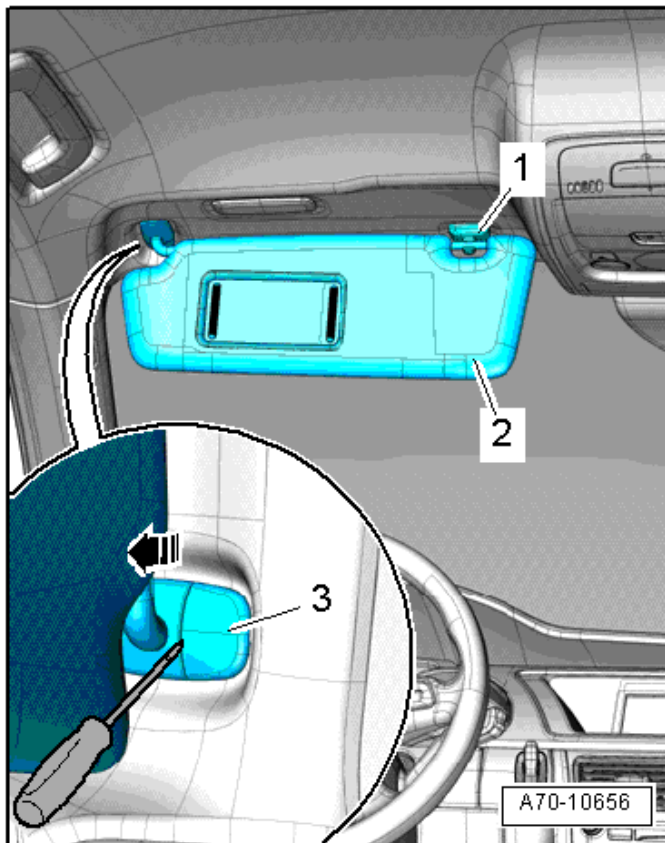

#### Remove sunvisors:

- Disengage the sun visor <1> in the center of the vehicle from the sun visor center bracket <2>.
- Unclip the expanding cap <3> using a screwdriver.
- Tilt the sun visor bracket down <arrow> and remove it.
- Versions with lighting: Disconnect the electrical connector and remove the sun visor.

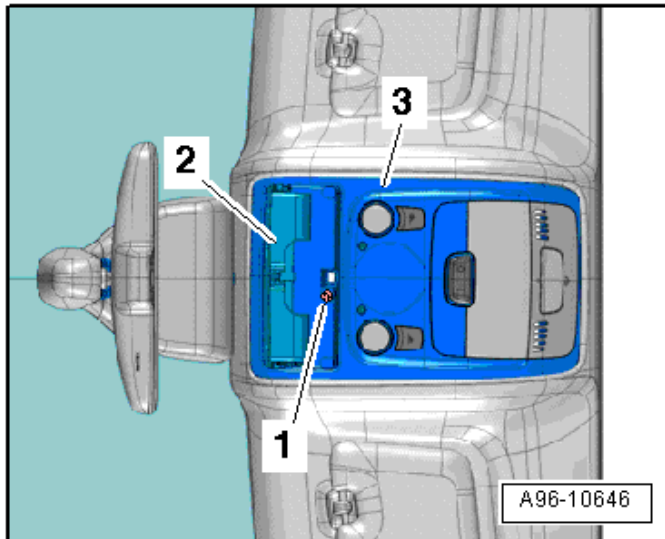

### Remove front reading lamp:

- Open the eyeglass compartment <2>.
- Remove the bolt <1>.
- Pivot the front interior lamp/reading lamp <3> downward and remove it from the roof trim panel.
- Disconnect the connectors.

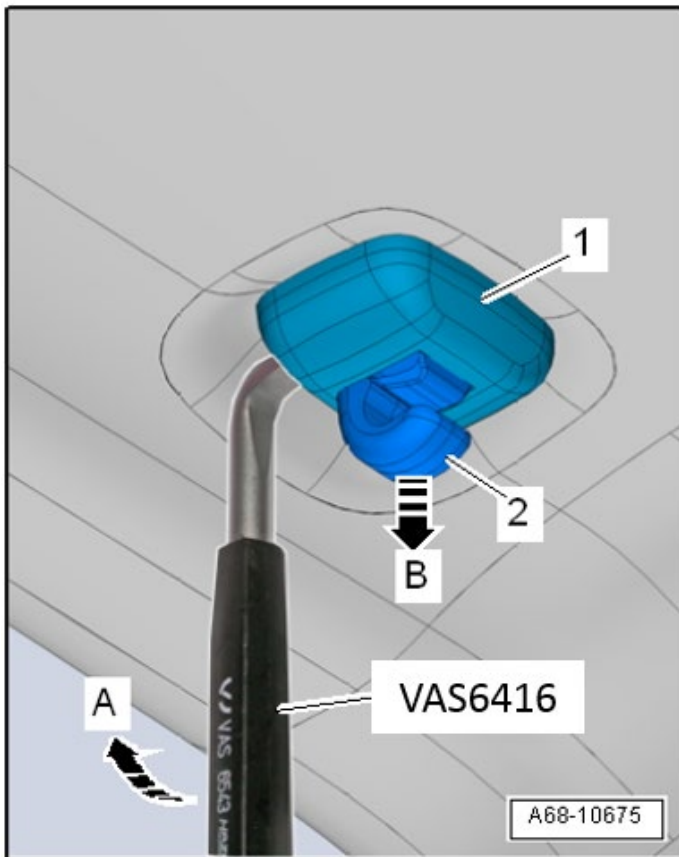

### Remove sun visor center supports:

- Unclip the sun visor center support cover <1> by sliding the -VAS6416- only about 1 mm under the cap in the direction of <arrow A>.

#### NOTE

If the -VAS6416- is inserted farther, it will be located under the sun visor. It is not possible then to pry out the expanding cap.

- Remove sun visor center support <2> in the direction of <arrow B>.
- Remove both sun visor center support covers.

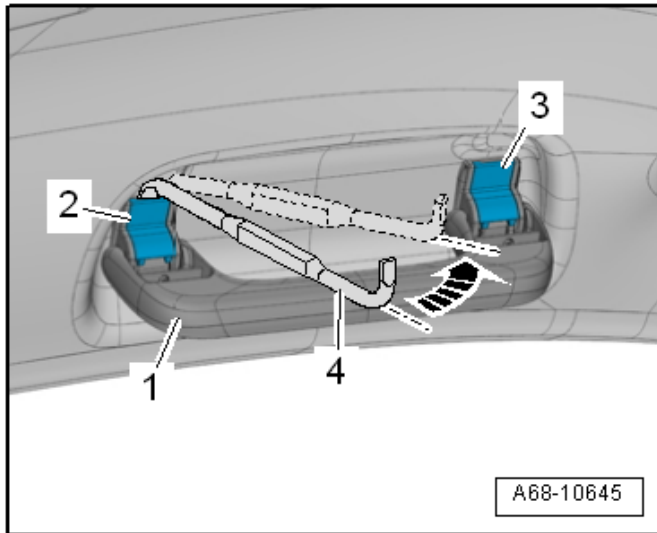

### Remove all four grab handles:

#### NOTE

- There is a risk of destroying the roof grab handle if the silicone brake and spring fall out. Replacement of the grab handle due to improper removal will not be covered under this action.
- Only unclip the expanding caps <2 and 3> up to their lock position. Do not remove them completely.
  - Place the angled screwdriver <4> in the gap behind the clips <2>.
  - Pivot the angled screwdriver in the direction of <arrow>, until the clips slide audibly into the rest position.
  - Repeat the procedure on clip <3>.
  - Remove the roof grab handle <1> from the body opening.
  - Leave the expanding caps in the rest position in the roof grab handle.

### For vehicles with a sliding sunroof:

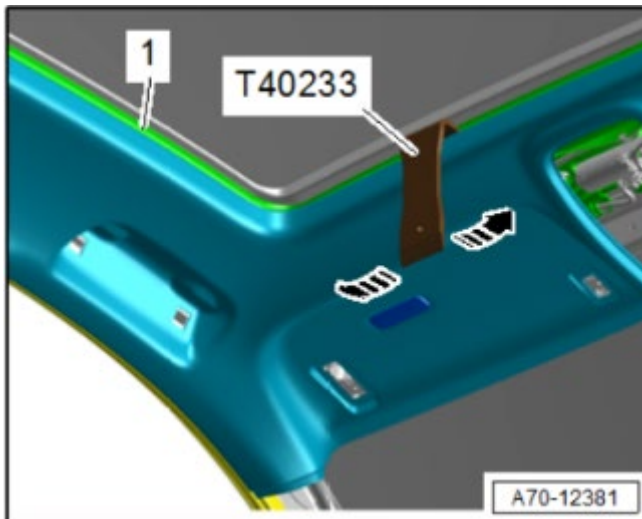

- Open the sun shade.
- To avoid dirtying the headliner, clean the -T40233-.
- Push the -T40233- between the frame <1> for the sliding sunroof and the headliner.
- Loosen the headliner using the -T40233- from the sliding sunroof frame all the way around <arrows>, as shown.



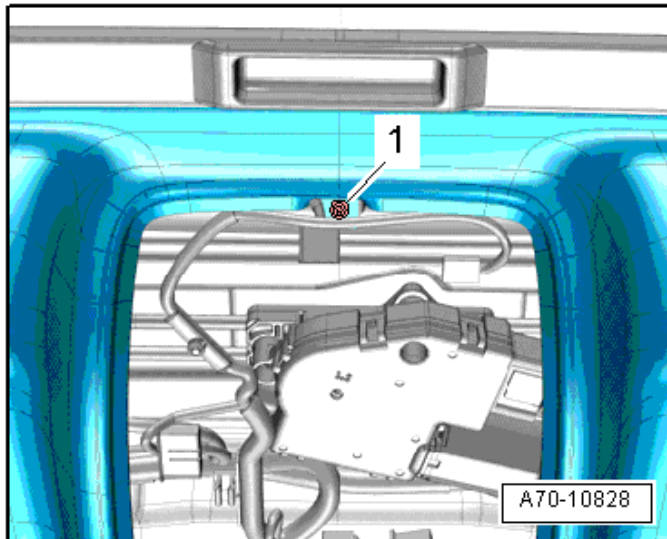

- Remove the bolt <1> in the front interior/reading light roof opening.

Continued for all vehicles:

Remove headliner:

**⚠ CAUTION**

The headliner bends easily.

**! NOTE**

Two technicians are needed to loosen the last connections and to remove the headliner.

- Release the clips in direction of <arrows> on the rear centering clip with a small screwdriver.

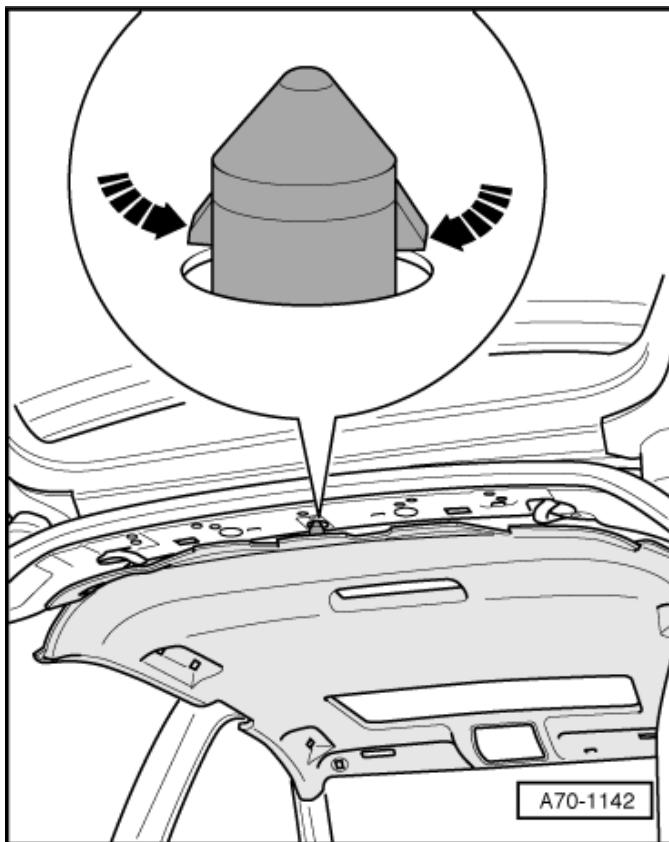

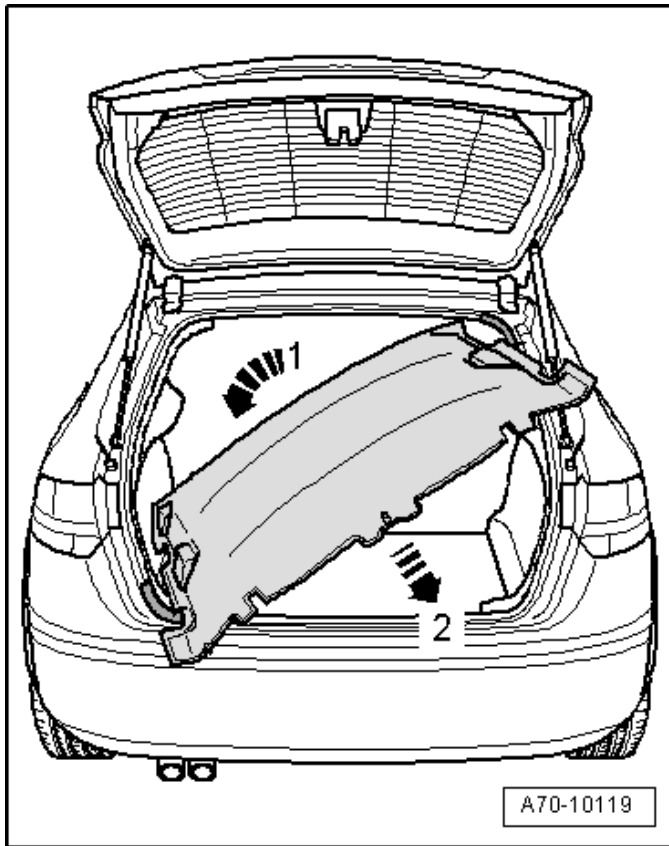

- Lower the headliner on the left side of the vehicle in direction of <arrow 1>.
- Remove the headliner through the opening for the rear lid in direction of <arrow 2>.

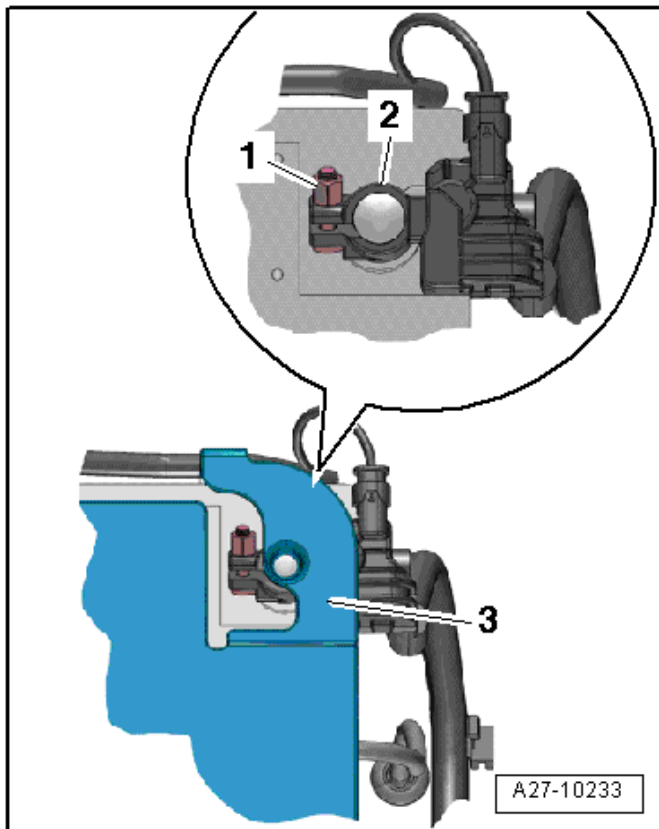

#### Disconnect the battery:

#### **⚠ WARNING**

Accident risk. When working on pyrotechnic components (such as airbags and belt tensioners), the battery must be disconnected with the ignition switched **ON**.

- Turn the ignition **ON**.
- Access the battery.
- Open the cover <3> over the battery negative terminal.
- Loosen the nut <1>.
- Remove and isolate the battery ground cable terminal from the battery pole.

#### **ⓘ NOTE**

Before disconnecting the battery, it is recommended to record the customer's radio presets so they can be restored before returning vehicle to the customer.

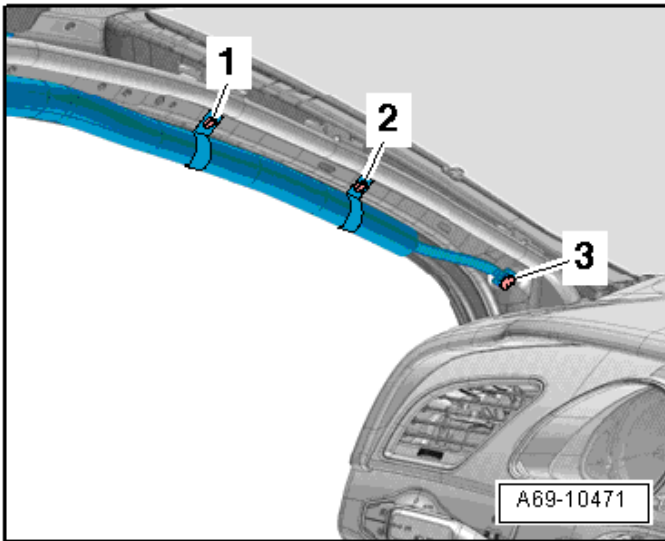

**Remove the head curtain airbag:**

- Criteria 01 – remove right side head curtain airbag.
- Criteria 02 – remove left side head curtain airbag.
- Remove head curtain airbag bolt <3> on the A-pillar.
- Remove the head curtain airbag from the clips <1> and <2>.

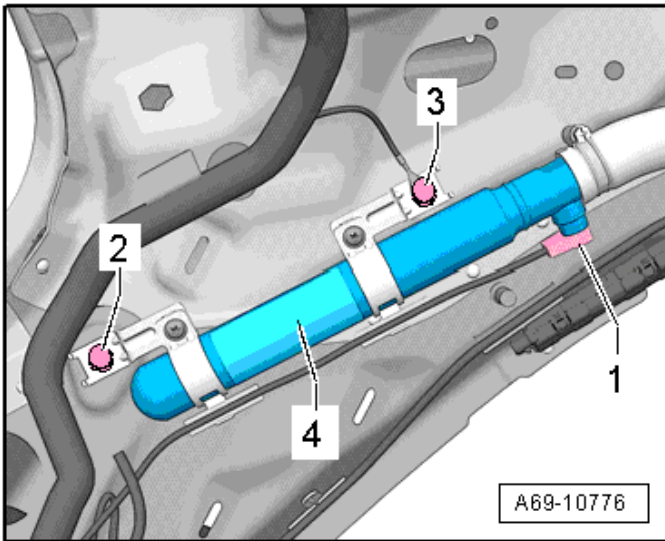

**⚠ WARNING**

Before handling pyrotechnic components (for example, disconnecting the connector), the person handling it must “discharge static electricity”. This can be done by touching the door striker, for example.

- Release connector lock and disconnect connector <1>.
- Remove cap nuts <2> and <3>.

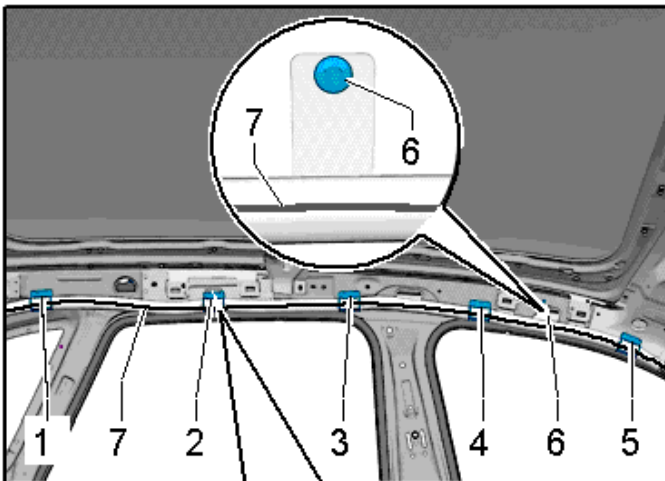

- Detach the clip <6>.

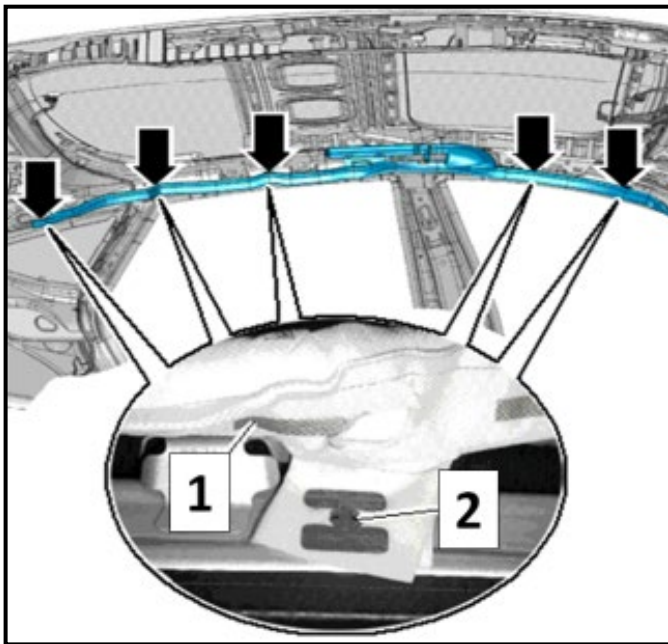

- Unclip the head curtain airbag clips from the body using -VAS211001-.
  - Fold airbag material <1> up to access clips <2>.
  - Guide the plier tips into the openings while holding the pliers open, press the clip catches for the head curtain airbag together and remove the clip.

**NOTE**

The clips <2> will become damaged during removal.

- Remove head curtain airbag from vehicle.

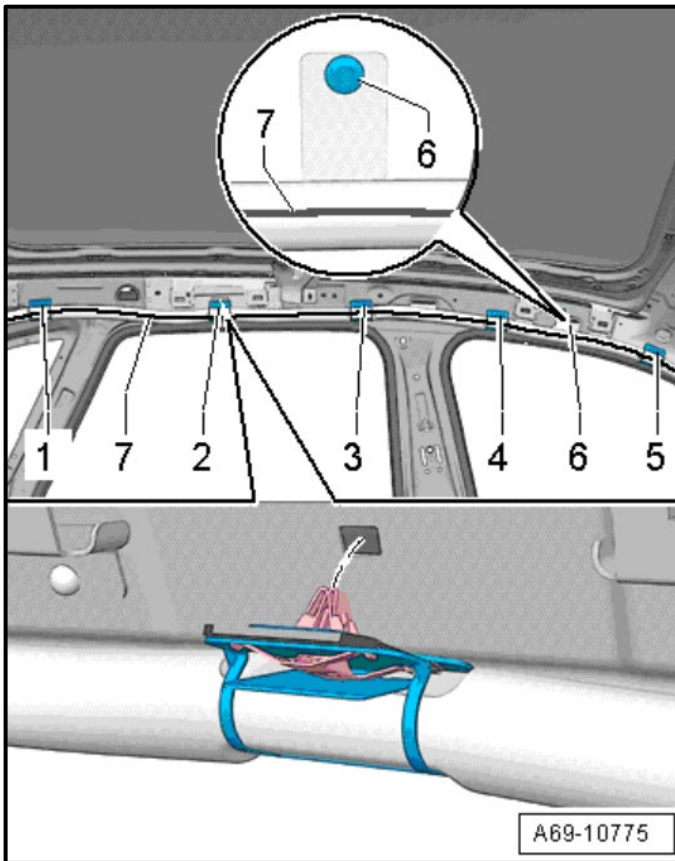

**Install new head curtain airbag:**

**WARNING**

Before handling pyrotechnic components (for example, disconnecting the connector), the person handling it must “discharge static electricity”. This can be done by touching the door striker, for example.

Crit	Part Number	Part Description
01	8R0-880-742-L	Right head curtain airbag
02	8R0-880-741-L	Left head curtain airbag

- Ensure the black strip <7> is visible along the entire length of the head curtain airbag.
- Ensure the head curtain airbag is not twisted.
- Clip the side curtain airbag retaining tab clips <1 through 5> onto the body.
- Clip the clips <6> onto the body.

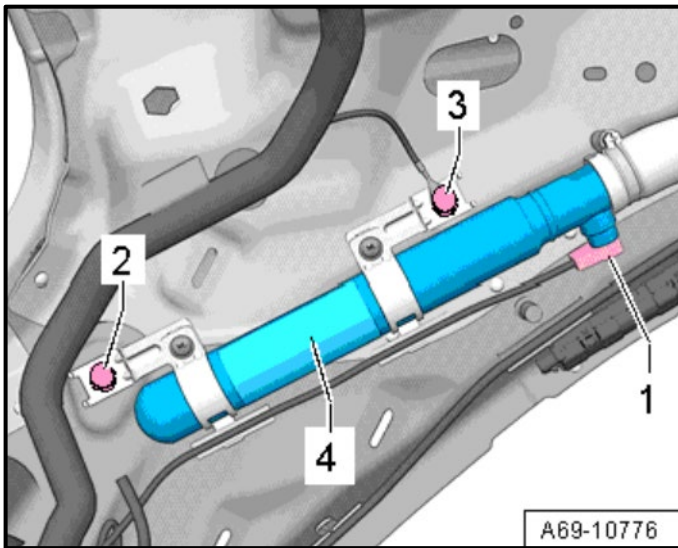

- Engage the head curtain airbag <4> on the bolt and tighten the cap nuts <2> and <3> by hand.
- Torque the cap nuts <2> and <3> to 9 Nm.
- Connect and lock connector <1>.

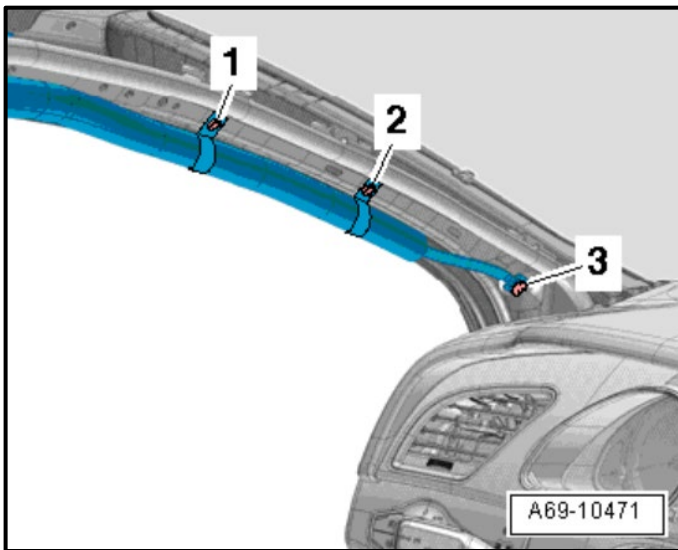

- Secure the head curtain airbag with the clips <1> and <2>.
- Attach the tensioning strap and torque new bolt <3> to 3.5 Nm.

Part Number	Part Description
N -912-259-01	Bolt

**Assemble all trim in the reverse order of removal:**

- Remove trim clips from body using Omega Clip Tool -T40280-.
- Torque fasteners as follows:
  - Interior light screws – 1.6 Nm.
  - Screen separator bolts – 9 Nm.
  - Luggage compartment screw – 3 Nm.
  - Tie down bolts – 6 Nm.

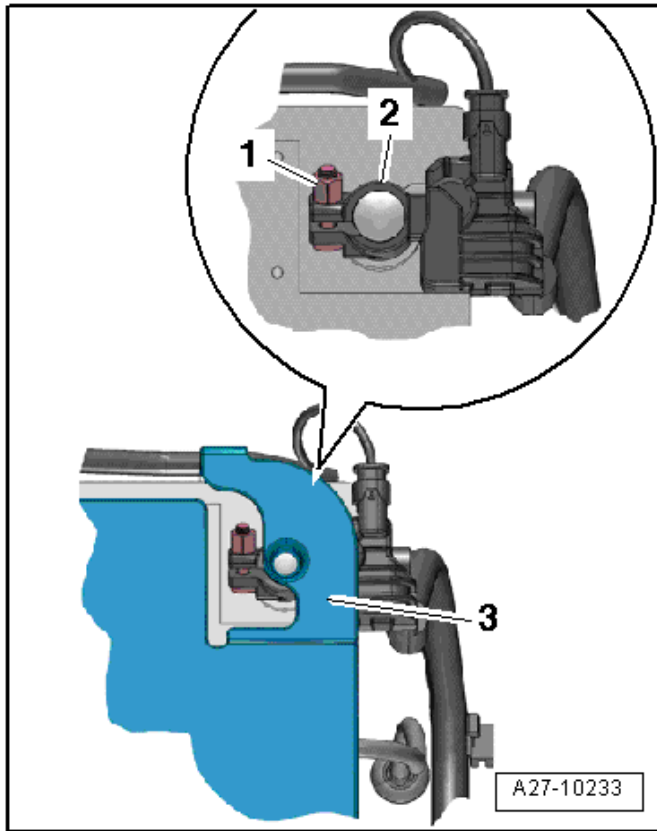

### ⚠ WARNING

Ignition must be **ON** when connecting battery. If pyrotechnic components (e.g. airbag, belt tensioner) are not repaired correctly, they may deploy unintentionally after connecting the battery. There must not be anyone inside the vehicle when connecting the battery.

- Disconnect the connector <2> from the Battery Monitoring Control Module -J367- <3>.
- Attach the battery ground cable clamp by hand to the battery negative terminal and torque the nut <1> to 6 Nm.
- Reconnect the connector to the Battery Monitoring Control Module -J367-.
- Re-install the luggage compartment floor.
- Cycle the ignition off and back on.
- Set clock to local time.
- Activate the power window regulator one-touch up/down function.
- Check the DTC memories of all the control units and erase under-voltage faults if necessary.



### Document vehicle and airbag information:

- Document the following on a piece of paper and attach (tape) it to the removed airbag before repackaging it for return:
  - VIN #
  - Vehicle mileage
  - Airbag module number <A>

### Proceed to Section C

## Section C – MANDATORY Parts Return Information

### IMPORTANT

DO NOT detonate the airbag prior to return. Airbags are to be returned in-tact and left in their as-removed state.

- All airbags replaced under Action 69BD must be returned to the designated inspection facility. Requests for all airbags will be available in the Warranty Parts Portal (WPP) once the claim has reached Approved status in SAGA.
- Airbags not returned or improperly returned are subject to claim cancellation.
- Action – 69BD claims will be cancelled in SAGA in the event the airbag requested for return through the WPP are not received or in-transit with FedEx by the request expiration date.
- Use the Warranty Parts Portal to obtain the FedEx shipping label and required hazardous material documentation.

## Appendix A – Warning and Safety Precautions

### WARNING

#### General Safety Precautions when Working with Pyrotechnic Components:

- Pyrotechnic components always contain propellant that generates a gas during combustion. In some components, there is also a supply of pressurized gas to ensure this gas is generated
- This pressurized gas is stored under high pressure in a compressed gas container. Pyrotechnic components are triggered by electrical/mechanical igniters.
- Only trained personnel should perform testing, assembly and servicing work. Airbags do not have a replacement interval.
- Never check with test lamps, voltmeter or ohmmeters.
- Only check pyrotechnic components when they are installed in the vehicle using vehicle diagnosis, testing and information systems approved by the manufacturer.
- When working on pyrotechnic components and the airbag control module, disconnect the battery ground strap while the ignition is switched on. Then cover the negative terminal.
- Wait 10 seconds after disconnecting the battery.
- The ignition must be SWITCHED ON when connecting the battery. There should not be anyone inside the vehicle when doing this.
- Exception: vehicles with batteries in the passenger compartment. In this case, stay outside the range of the airbags and seat belts.
- Wash your hands after touching ignited pyrotechnic components from the restraint system.
- Do not open or repair pyrotechnic components. Use only new components to reduce the risk of injury.
- Do not install pyrotechnic components that have fallen onto a hard surface or show signs of damage.
- Discharge static electricity before handling pyrotechnic components, for example before disconnecting the electrical connector. This can be done by touching grounded metal objects such as the door striker pin.
- Install pyrotechnic components immediately after removing them from their transport packaging. If you must stop working, store the pyrotechnic component in its original transport packaging.
- Do not leave pyrotechnic components lying in the open unattended.
- Do not treat pyrotechnic components with grease, cleaning solutions or similar products.
- Do not expose pyrotechnic components to temperatures above 100 °C, even for brief periods of time.
- People in the immediate vicinity of the workplace must be protected from possible noise and projectiles.
- Pyrotechnic components can trigger unintentionally.
- In the event of deployment:
  - Single-stage inflators: allow airbag to cool down completely. Wait at least 10 minutes before handling.
  - Two-stage inflators: wait for second airbag ignition. Allow airbag to cool down completely. Wait at least 10 minutes before handling.