

Technical product information

Topic	During PDI - Steering wheel vibration and/or steering wheel out of alignment is evident
Market area	Russische Föderation (5RU),Australia E04 Bentley rest Asia and Australia (6E04),China 796 VW Import Comp. Ltd (Vico), Beijing (6796),Germany E02 Bentley rest Europe (6E02),Japan E03 Bentley Japan (6E03),Korea, (South) E08 Bentley South Korea (6E08),United Arab Emirates E06 Bentley Middle East and Africa (6E06),United Kingdom E01 Bentley UK (6E01),United States E05 Bentley USA and rest America (6E05)
Brand	Bentley
Transaction No.	2060223/3
Level	EH
Status	Approval
Release date	

New customer code

Object of complaint	Complaint type	Position
running gear -> steering system	noise, vibration	
running gear -> steering system	dimensional accuracy	
running gear -> steering system	functionality	
running gear -> steering, power-assisted steering -> steering wheel centre position	functionality -> incorrectly adjusted	

Vehicle data

New Continental GT/C - New Flying Spur - Bentayga

Sales types

Type	MY	Brand	Designation	Engine code	Gearbox code	Final drive code
3S3*	2018	E		*	*	*
3S3*	2019	E		*	*	*
3S3*	2020	E		*	*	*
3S3*	2021	E		*	*	*
3S4*	2019	E		*	*	*
3S4*	2020	E		*	*	*
3S4*	2021	E		*	*	*
4V1*	2017	E		*	*	*
4V1*	2018	E		*	*	*
4V1*	2019	E		*	*	*
4V1*	2020	E		*	*	*
4V1*	2021	E		*	*	*
ZG2*	2020	E		*	*	*
ZG2*	2021	E		*	*	*

Documents

Document name
master.xml

Customer statement / workshop findings

VERY IMPORTANT: This TPI is only applicable to vehicles which have the following issues found during the Pre Delivery Inspection (PDI)

Vehicle is pulling to the left or right

Or

Steering wheel vibration Or

General vehicle geometry concerns

Technical background

In the event that during the Pre Delivery Inspection procedure (PDI) the steering wheel is shaking/vibrating or out of alignment, please refer to the instructions within the Measure section

IMPORTANT: The steering geometry procedure should only be conducted by the retailer once permission has been given from Product Support via an existing or new DISS query

Production change

-

Measure

VERY IMPORTANT: This TPI is only applicable to vehicles which have the following issues found during the Pre Delivery Inspection (PDI)

Vehicle is pulling to the left or right

Or

Steering wheel vibration Or

General vehicle geometry concerns

- Tyre Pressures to be recorded and checked against the correct specification – Actual results should be requested and attached to the DISS query
- Referring to Figure 1 - Images of the track rod end threads before and after alignment from both sides should be requested and attached to the open DISS query
- *Measure and note down dimension -a- between the track rod ball joint -1- and the track rod -2- on both sides.*

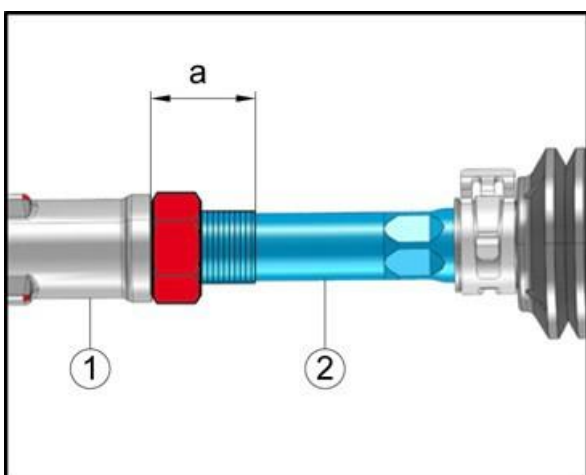

Figure 1

- Geometry results before and after alignment should be requested and attached to the open DISS query
- Vehicle ride heights before and after alignment should be requested and attached to the open DISS query