

February 11, 2021

Version 2

Warranty Extension: MIL Comes On with DTC P0420/P0430, P030x, and/or P219A/B (With Software Update)

Supersedes 20-100, dated November 24, 2020, to revise the information highlighted in yellow.

This bulletin replaces 18-025, *MIL Comes On with DTC P0300-P0306 or P219A/B*, and 19-072, *MIL Comes On with DTC P0430 or P0430 with P030X, P219A, P219B (With Software Update)*.

AFFECTED VEHICLES

Year	Model	Trim Level	VIN Range
2018	Odyssey	ALL	Check the iN VIN status for eligibility.
2016-17	Pilot	ALL	Check the iN VIN status for eligibility.
2017	Ridgeline	ALL	Check the iN VIN status for eligibility.

REVISION SUMMARY

Under AFFECTED VEHICLES, WARRANTY CLAIM INFORMATION, and SOFTWARE INFORMATION, 2017 Pilot, 2017 Ridgeline, and 2018 Odyssey were added.

BACKGROUND

The PCM software may misinterpret sensor inputs as a deteriorated catalytic converter. Additionally, debris from the high pressure pump or the fuel injector machining process can cause internal wear or clogging inside one or more injectors. One or more of the following DTCs may be stored:

- P0420 (rear bank catalyst system efficiency below threshold [bank 1])
- P0430 (front bank catalyst system efficiency below threshold [bank 2])
- P0300-P0306 (misfire)
- P219A (air-fuel ratio variation of cylinder [bank 1, rear bank])
- P219B (air-fuel ratio variation of cylinder [bank 2, front bank])

American Honda is extending the warranty on these repairs to **10 years** from the original date of purchase or 150,000 miles, whichever comes first.

CUSTOMER NOTIFICATION

Owners of affected vehicles will be sent a notification of this campaign.

Do an iN VIN status inquiry to make sure the vehicle is shown as eligible.

CUSTOMER INFORMATION: The information in this bulletin is intended for use only by skilled technicians who have the proper tools, equipment, and training to correctly and safely maintain your vehicle. These procedures should not be attempted by "do-it-yourselfers," and you should not assume this bulletin applies to your vehicle, or that your vehicle has the condition described. To determine whether this information applies, contact an authorized Honda automobile dealer.

CORRECTIVE ACTION

Do the following repairs depending on the stored DTC:

P0420 or P0430 only - Update the software, and do the cylinder AF test. If the test fails, replace the fuel injectors.

NOTE:

- If the vehicle has a 9-speed A/T, make sure the A/T software is up to date. The A/T software may have been updated in service bulletin 19-072, *MIL Comes On with DTC P0430 or P0430 with P030X, P219A, P219B (With Software Update)*.
- If the vehicle has a 6- or 10-speed A/T, you do not need to check the A/T software.

P0420 or P0430, and any combination of P0300 through P0306, P219A, or P219B - Update the software, and replace the fuel injectors.

NOTE:

- If the vehicle has a 9-speed A/T, make sure the A/T software is up to date. The A/T software may have been updated in service bulletin 19-072, *MIL Comes On with DTC P0430 or P0430 with P030X, P219A, P219B (With Software Update)*.
- If the vehicle has a 6- or 10-speed A/T, you do not need to check the A/T software.

P0300 through P0306, P219A, or P219B only - Replace the fuel injectors.

NOTE: The vehicle must have **5,000 miles or more** on the odometer.

WARRANTY CLAIM INFORMATION

Template IDs were not included because there are multiple repair variations. Document the inspection and test results on the repair order, and manually enter the warranty claim depending on which repair(s) were done.

Odyssey

Operation Number	Description	Flat Rate Time	Defect Code	Symptom Code	Failed Part Number
1255G2	Update the PGM-FI software.	0.2 hr	6E600	W8V00	37805-RLV-315
1105D4	Do the cylinder AF test.	0.1 hr			10004-RLV-A00
1211NC	Replace the fuel injectors.	2.6 hr			16010-RLV-315
1245B7	Confirm and update 9-speed A/T software.	0.1 hr			37805-RLV-315

Pilot

Operation Number	Description	Flat Rate Time	Defect Code	Symptom Code	Failed Part Number
1255G2	Update the PGM-FI software.	0.2 hr	6E600	W8V00	37805-RLV-315
1105D4	Do the cylinder AF test.	0.1 hr			10004-RLV-A00
1211NC	Replace the fuel injectors.	2.5 hr			16010-RLV-315
1245B7	Confirm and update 9-speed A/T software.	0.1 hr			37805-RLV-315

Ridgeline

Operation Number	Description	Flat Rate Time	Defect Code	Symptom Code	Failed Part Number
1255G2	Update the PGM-FI software.	0.2 hr	6E600	W8V00	37805-RLV-315
1105D4	Do the cylinder AF test.	0.1 hr			10004-RLV-A00
1211NC	Replace the fuel injectors.	2.2 hr			16010-RLV-315

Skill Level: Repair Technician

PARTS INFORMATION

Part Name	Part Number	Quantity
Fuel Injector Kit*	06160-RLV-305	1

*Includes new fuel injectors and all must-replace parts.

SOFTWARE INFORMATION

NOTE: Unnecessary or incorrect repairs resulting from a failure to update the i-HDS are not covered under warranty.

Before beginning the repair, make sure all diagnostic and reprogramming software are updated as listed.

i-HDS Software Version	1.005.038 or later
J2534 Rewrite Software Information	
PC Application Version	1.1.0.6 or later
Database Update	25-NOV-2019 or later

Do only the update listed in this service bulletin.

You cannot apply the updates with the MVCI as a standalone tool. To update the software you must use the MVCI or the DST-i interface in conjunction with the J2534 Rewrite PC application on the i-HDS.

For more information about updating the i-HDS, the MVCI, and vehicle systems, refer to service bulletin 01-023, *Updating Control Units/Modules*.

Year/Model	Vehicle System	Program ID (or later)	Program P/N (or later)
2018 Odyssey *LX	PGM-FI	MRA040	37805-5MR-A04
2018 Odyssey *EX	PGM-FI	MRA250	37805-5MR-A25
2018 Odyssey *EX-L	PGM-FI		
2018 Odyssey *EX-L (NAVI, RES)	PGM-FI		
2018 Odyssey Touring	PGM-FI	MRA750	37805-5MR-A75
2018 Odyssey Elite	PGM-FI		
2016 Pilot LX 2WD	PGM-FI	LV3150	37805-RLV-315
2016 Pilot EX 2WD	PGM-FI		
2016 Pilot EX-L 2WD	PGM-FI		
2016 Pilot EX-L (NAVI) 2WD	PGM-FI		
2016 Pilot EX-L (RES) 2WD	PGM-FI		
2016 Pilot LX 4WD	PGM-FI	LV3160	37805-RLV-316
2016 Pilot EX 4WD	PGM-FI		
2016 Pilot EX-L 4WD	PGM-FI		
2016 Pilot EX-L (NAVI) 4WD	PGM-FI		
2016 Pilot EX-L (RES) 4WD	PGM-FI	LV3170	37805-RLV-317
2016 Pilot EX (Sensing) 2WD	PGM-FI		
2016 Pilot EX-L (Sensing) 2WD	PGM-FI		

*Confirm the 9-speed A/T software is up to date.

Year/Model	Vehicle System	Program ID (or later)	Program P/N (or later)
2016 Pilot EX (Sensing) 4WD	PGM-FI	LV3180	37805-RLV-318
2016 Pilot EX-L (Sensing) 4WD	PGM-FI		
2016 Pilot Touring* (9A/T) 2WD	PGM-FI	LV4060	37805-RLV-406
2016 Pilot Touring* (9A/T) 4WD	PGM-FI	LV4070	37805-RLV-407
2016 Pilot Elite* (9A/T) 4WD	PGM-FI		
2017 Pilot LX 2WD	PGM-FI	LVC030	37805-RLV-C03
2017 Pilot EX 2WD	PGM-FI		
2017 Pilot EX-L 2WD	PGM-FI		
2017 Pilot EX-L (NAVI) 2WD	PGM-FI		
2017 Pilot EX-L (RES) 2WD	PGM-FI		
2017 Pilot LX 4WD	PGM-FI	LVC130	37805-RLV-C13
2017 Pilot EX 4WD	PGM-FI		
2017 Pilot EX-L 4WD	PGM-FI		
2017 Pilot EX-L (NAVI) 4WD	PGM-FI		
2017 Pilot EX-L (RES) 4WD	PGM-FI		
2017 Pilot EX (Sensing) 2WD	PGM-FI	LVC230	37805-RLV-C23
2017 Pilot EX-L (Sensing) 2WD	PGM-FI		
2017 Pilot EX (Sensing) 4WD	PGM-FI	LVC330	37805-RLV-C33
2017 Pilot EX-L (Sensing) 4WD	PGM-FI		
2017 Pilot *Touring (9A/T) 2WD	PGM-FI	LVC430	37805-RLV-C43
2017 Pilot *Touring (9A/T) 4WD	PGM-FI	LVC530	37805-RLV-C53
2017 Pilot *Elite (9A/T) 4WD	PGM-FI		
2017 Ridgeline RTL 4WD	PGM-FI	MJA560	37805-5MJ-A56
2017 Ridgeline RTL-T 4WD	PGM-FI		
2017 Ridgeline Sport 4WD	PGM-FI		
2017 Ridgeline Black 4WD	PGM-FI	MJA760	37805-5MJ-A76
2017 Ridgeline RTL-E 4WD	PGM-FI		
2017 Ridgeline RT 2WD	PGM-FI	MJA060	37805-5MJ-A06
2017 Ridgeline RTL 2WD	PGM-FI		
2017 Ridgeline RTL-T 2WD	PGM-FI		
2017 Ridgeline Sport 2WD	PGM-FI		

*Confirm the 9-speed A/T software is up to date.

INSPECTION

1. Connect the HDS, and do an all-DTC check.

Are any of the DTCs listed below present?

- P0420
- P0430
- P0300-P0306
- P219A
- P219B

Yes - Do the following depending on the DTC(s) present:

- **P0420 or P0430 only** - Go to the next step to start the PGM-FI software update.
- **P0420 or P0430, and any combination of P0300 through P0306, P219A, or P219B** - Go to the next step to start the PGM-FI software update.
- **P0300 through P0306, P219A, or P219B only** - Go to REPAIR PROCEDURE.

No - This service bulletin does not apply. Continue with normal system troubleshooting.

2. Update the PGM-FI software using the i-HDS J2534 rewrite software with the MVCI or DST-i. Refer to Service Bulletin 01-023, *Updating Control Units/Modules*.

NOTE:

- If the vehicle has a 9-speed A/T, make sure the A/T software is up to date. The A/T software may have been updated in service bulletin 19-072, *MIL Comes On with DTC P0430 or P0430 with P030X, P219A, P219B (With Software Update)*.
- If the vehicle has a 6- or 10-speed A/T, you do not need to check the A/T software.

Are DTCs P0300 through P0306, P219A, or P219B present?

Yes - Go to REPAIR PROCEDURE.

No - Go to the next step to start the cylinder AF test.

3. Select **Honda Systems**.

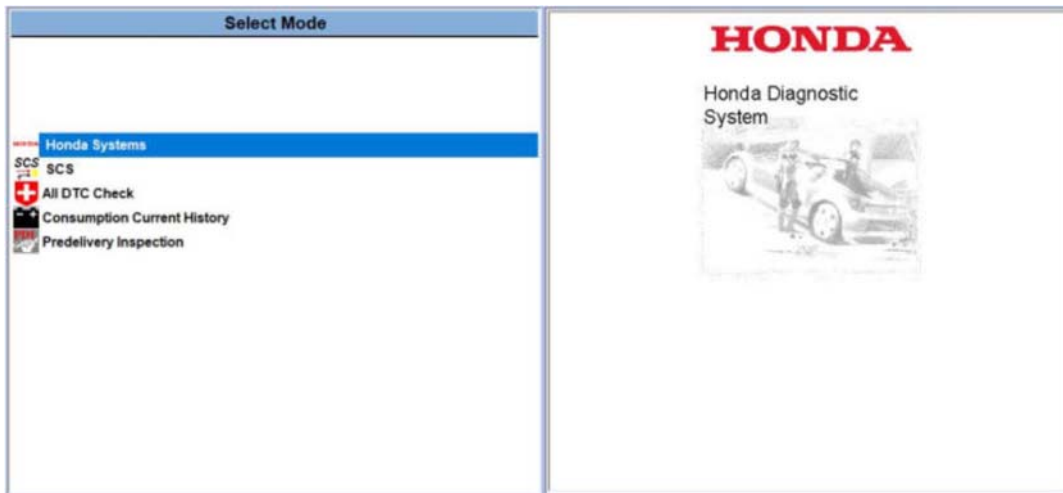

4. Select **PGM FI**.

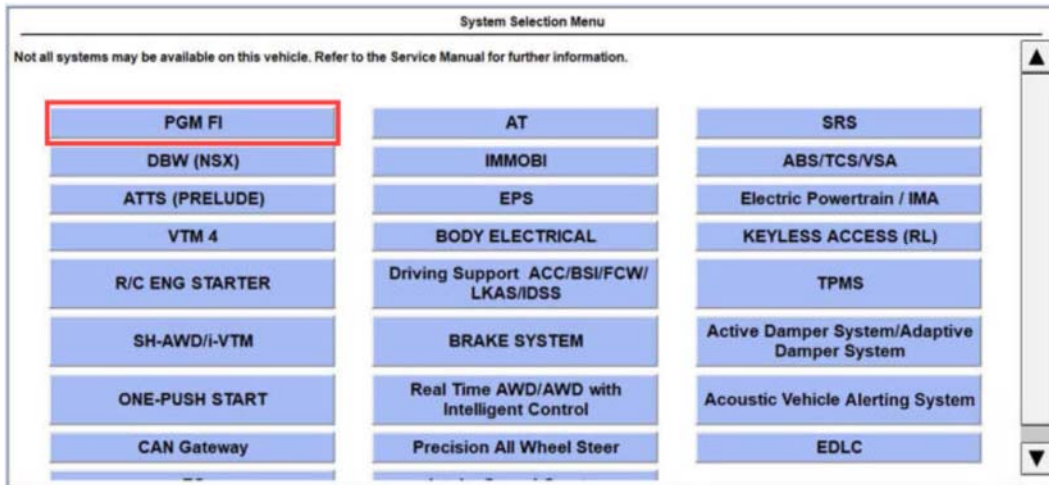

5. Select **PGM FI**.

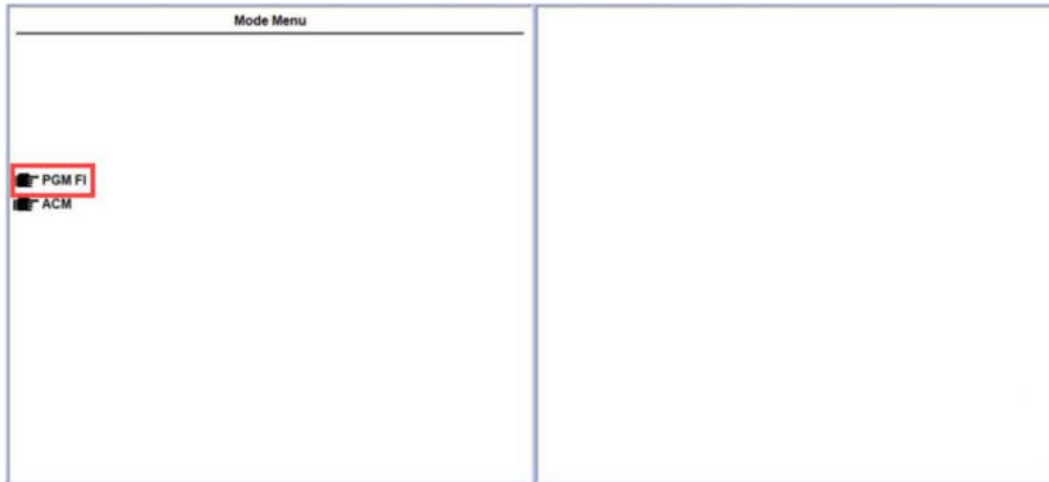

6. Select **Inspection**.



7. Select **Cylinder AF Test**.

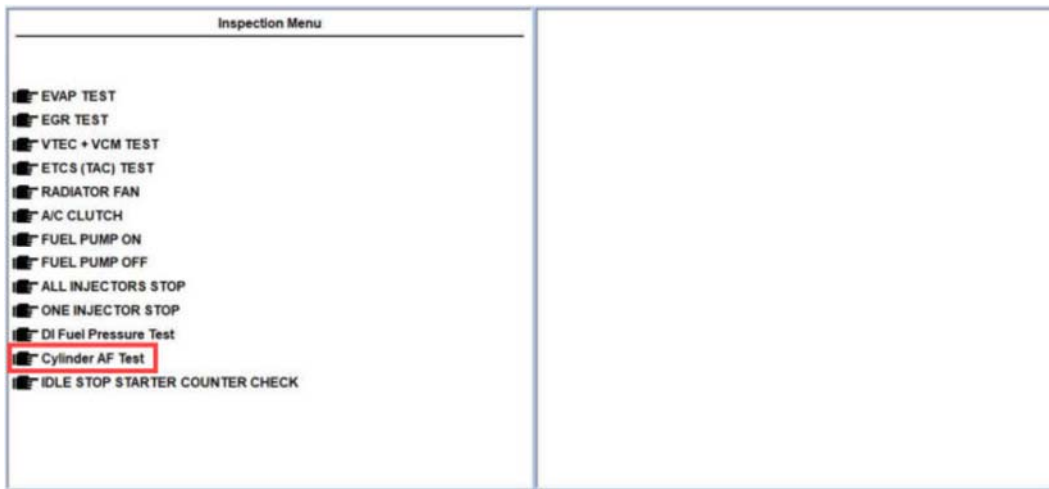

8. Make sure all cylinders pass.

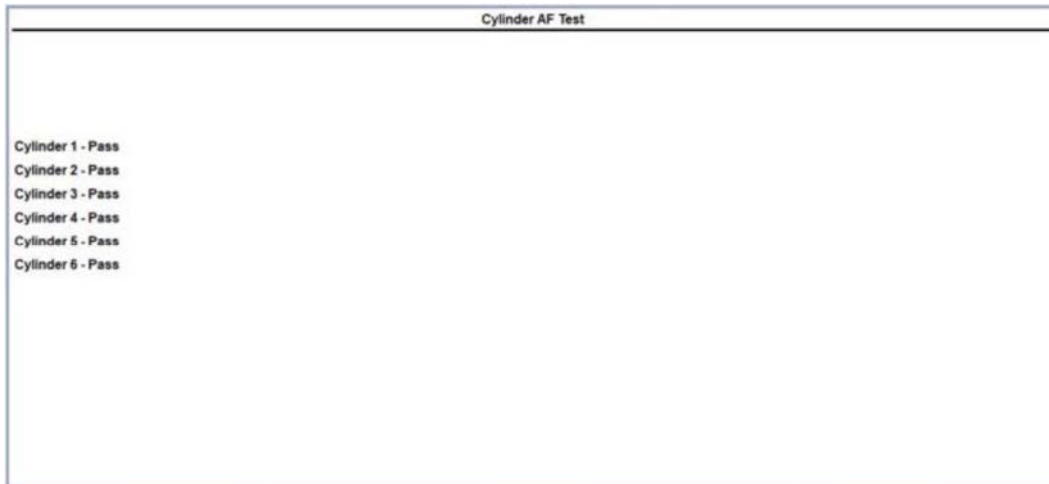

Did all cylinders pass?

Yes - The repair is complete.

No - Go to REPAIR PROCEDURE.

REPAIR PROCEDURE

1. Relieve the fuel pressure.
2. Disconnect the negative terminal from the 12-volt battery.
3. Remove the intake manifold and intake manifold base.
4. Remove the high pressure fuel pump cover.
5. Remove the fuel rail cover.
6. Remove the fuel joint pipe.
7. Remove the fuel rail and fuel injectors.
8. Replace the fuel injectors in the fuel rail.
9. Install the fuel rail and new fuel injectors into the cylinder head.
10. Lubricate the tips of the new fuel joint pipe with polyethylene glycol included in the fuel injector kit.
11. Lubricate the threaded areas of the fuel rails and high pressure fuel pump with polyethylene glycol.

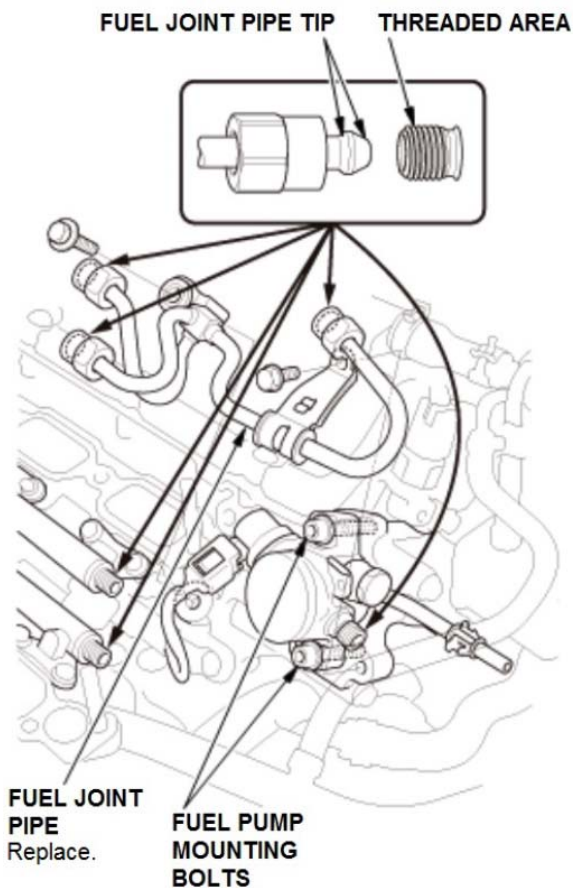

12. Loosen the fuel pump mounting bolts.
13. Install the new fuel joint pipe.

NOTE: Do not reuse the fuel joint pipe. Failure to install a new fuel joint pipe will cause fuel leaks.

14. Tighten the fuel joint pipe nuts by hand until the tips of the fuel joint pipe are seated on the fuel rails and the high pressure fuel pump.

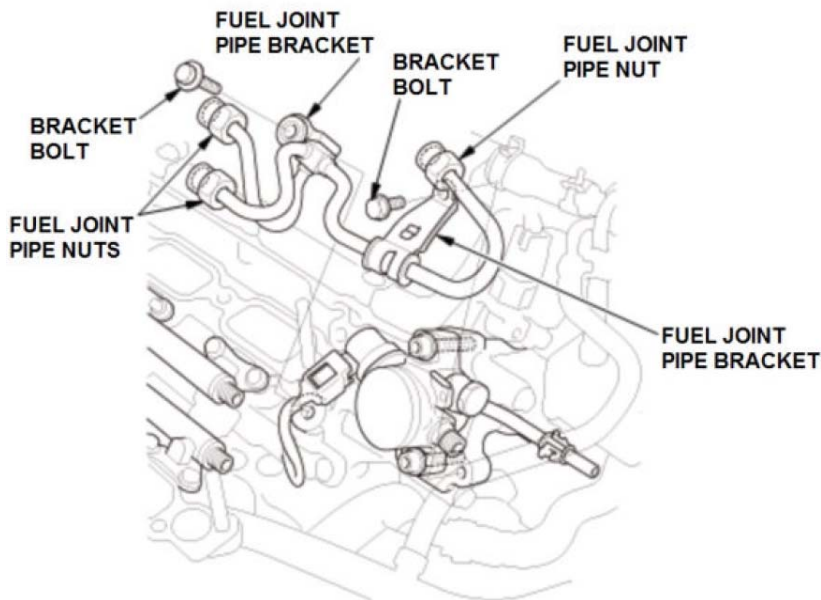

15. Loosely install the bracket bolts to secure the new fuel joint pipe to the cylinder head.
16. Tighten the fuel pump mounting bolts to **25 N·m (18 lb-ft)**.

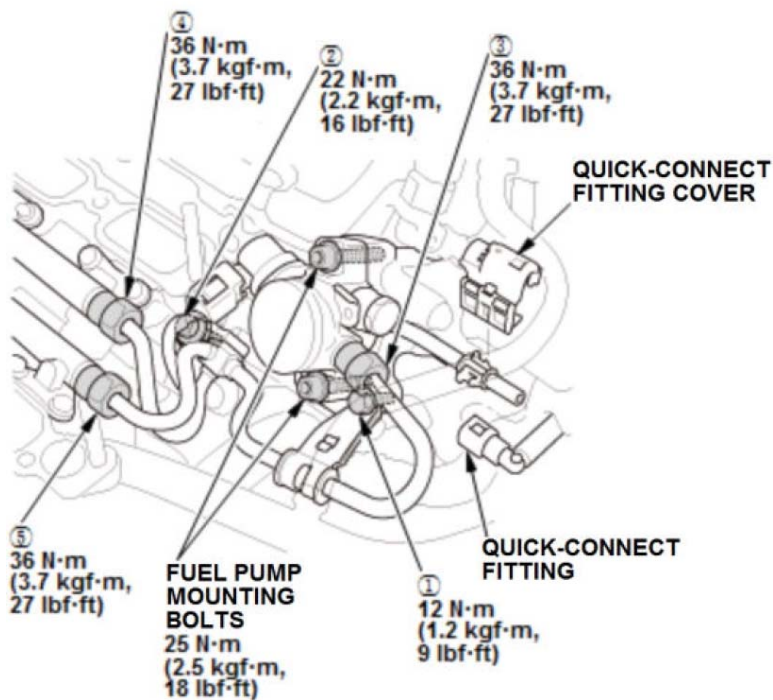

17. Tighten the fuel joint pipe bracket bolts to **12 N·m (9 lb-ft)** and **22 N·m (16 lb-ft)** in the order shown.
18. Tighten the fuel joint pipe nuts to **36 N·m (27 lb-ft)** in the order shown.

NOTE:

- A crowfoot-type special tool increases the torque applied by the torque wrench. Refer to Torque Specifications on SIS for details on how to recalculate the torque wrench setting.
- Failure to tighten the fuel joint pipe nuts to the proper torque will cause a fuel leak.

19. Connect the quick-connect fitting and install the quick-connect fitting cover.
20. Connect the negative terminal to the 12-volt battery.
21. Check for fuel leaks.
22. Install the fuel rail cover.
23. Install the high pressure fuel pump cover.
24. Install the intake manifold base and intake manifold.
25. Do an all-DTC check, and clear any DTCs from all systems.

END