

MIL ON With DTCs P0A94, P324E, P0A1A, and/or P3004

Service Category Engine/Hybrid System

Section Hybrid/Battery Control System

Market USA

Toyota Supports
 ASE Certification 

Applicability

YEAR(S)	MODEL(S)	ADDITIONAL INFORMATION
2012 - 2017	Prius V	
2010 - 2015	Prius	

SUPERSESSION NOTICE

The information contained in this bulletin supersedes Service Bulletin No. T-SB-0036-16.

- Warranty Information section has been updated.

Service Bulletin No. T-SB-0036-16 is obsolete and any printed versions should be discarded.

Introduction

Some 2010 – 2015 model year Prius and 2012 – 2017 model year Prius V vehicles may exhibit a MIL ON condition with Diagnostic Trouble Codes (DTCs) P0A94, P324E, P0A1A, and/or P3004, indicating a malfunction has occurred in the inverter assembly with converter. Follow the Repair Procedure in this bulletin to identify the specific components within the inverter assembly with converter that need to be replaced and address this condition.

MIL ON With DTCs P0A94, P324E, P0A1A, and/or P3004

Warranty Information

OP CODE	DESCRIPTION	MODEL	TIME	OFF	T1	T2
EL1602	R & R Inverter Assembly With Converter	Prius	2.0	G9200-#####	8A	73
EL1625		Prius V	1.6			
EL1603	R & R IPM Transistor	Prius	2.9			
		Prius V	2.9			
EL1604	R & R IPM Transistor and MG ECU	Prius	2.9			
		Prius V	2.9			

APPLICABLE WARRANTY

- This repair is covered under the Toyota Hybrid System Warranty. This warranty is in effect for 96 months or 100,000 miles, whichever occurs first, from the vehicle's in-service date.
- Warranty application is limited to occurrence of the specified condition described in this bulletin.
- For 2004 – 2017 model year Prius vehicles that are registered and normally operated in California, Arizona (2012 model year only), Connecticut (starting with 2005 model year), Maine (starting with 2004 model year), Maryland (starting with 2011 model year), Massachusetts (starting with 2004 model year), New Hampshire (2005 model year – 2009 model year only), New Jersey (starting with 2005 model year), New Mexico (2010 – 2011 model year only), New York (beginning with 2004 model year with ZE models only; all models starting with 2016 model year), Oregon (starting with 2008 model year), Rhode Island (starting with 2005 model year), and Vermont (starting with 2004 model year) – Partial Zero Emission Vehicle (PZEV) Emission Warranty Coverage is in effect for 15 years or 150,000 miles, from the vehicle's in-service date, whichever occurs first. (Please reference Warranty Policy Bulletin POL14-09 for additional information)

MIL ON With DTCs P0A94, P324E, P0A1A, and/or P3004

Parts Information

NOTE

- This section is for reference ONLY. The parts listed below are NOT all required for inverter assembly with converter repairs.
- Order the correct part number by entering the VIN number into the Electronic Parts Catalog (EPC).

PART NUMBER*1	PART NAME	QTY
G9200-##### (Order by VIN)	Inverter Assy, W/Converter	1*2
G920H-##### (Order by VIN)	Computer Sub-assy, MG Control W/Bracket	1*2
G920J-52010	Sensor Sub-assy, Inverter Current	1*2
G9208-47090	Wire Sub-assy, Inverter	1*2
04899-47070	Transistor Kit, Power Module Intelligent (IPM)	1*2,*7
08826-00100	Seal Packing or Equivalent	1*2
00272-SLLC2	Super Long Life Coolant	1*3
04899-47060	Plug Kit, Inverter Drain	1*3
90430-18008	Gasket	1*3
G922L-47010	Cover, Inverter Signal Connector	1*4
91551-80618	Bolt, Flange	15*4
091X1-47020	Seal, Masking, No. 1	1*5
08887-02809	Toyota Thermal Grease X-23-7884-4	2*6

*1 Part numbers are subject to change. Order the correct part number by inputting the VIN in the EPC.

*2 Refer to step 3 in this Service Bulletin to determine if the part is required.

*3 Required for ANY Repair Procedure in this Service Bulletin.

*4 NOT required. Available in case of breakage.

*5 Included in IPM Kit. Available if spare is needed.

*6 Used ONLY for IPM replacement. Part has shelf life of one year. Do NOT use if stored past one year.

*7 The appearance of the replacement IPM may be different than the original part.

MIL ON With DTCs P0A94, P324E, P0A1A, and/or P3004

Required Tools & Equipment

REQUIRED EQUIPMENT	SUPPLIER	PART NUMBER	QTY
Techstream ADVI*	ADE	TSADVUNIT	1
Techstream 2.0		TS2UNIT	
Techstream Lite		TSLITEPDLR01	
Techstream Lite (Green Cable)		TSLP2DLR01	

*Essential SST.

NOTE

- Only ONE of the Techstream units listed above is required.
- Software version 15.30.027 or later is required.
- Additional Techstream units may be ordered by calling Approved Dealer Equipment (ADE) at 1-800-368-6787.

SPECIAL SERVICE TOOLS (SST)	PART NUMBER	QTY
Anti-static Mat*	09890-47010-01	1
Squeegee*	09891-47010-1A	1
Torque Wrench Adapter*	09961-00950	1
Inverter Case Separator*	09891-47020-01	1
Electrical Insulating Gloves*	01413-00072 (Medium)	1
	01413-00073 (Large)	
	01413-00074 (Extra Large)	

*Essential SST.

CAUTION

ALWAYS inspect electrical insulating gloves before use for cracks, ruptures, tears, pinholes, or damage. Do **NOT** wear if damaged.

NOTE

Additional SSTs may be ordered by calling 1-800-933-8335.

MIL ON With DTCs P0A94, P324E, P0A1A, and/or P3004

Repair Procedure

1. Confirm the condition exists.
 - A. Are DTCs P0A94, P324E, P0A1A, and/or P3004 stored?
 - **YES** — Continue to substep B.
 - **NO** — This bulletin does NOT apply. Continue diagnosis using the applicable Repair Manual.
 - B. Does the vehicle exhibit physical damage to the inverter assembly with converter in the location shown?
 - **YES** — Continue to step 2.
 - **NO** — Go to step 3.

Figure 1.

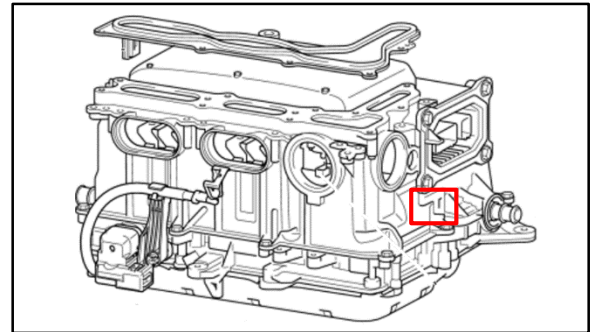

2. Replace the inverter assembly with converter.
Refer to TIS, applicable model and model year Repair Manual:
 - 2010 Prius:
Engine/Hybrid System – Hybrid/Battery Control System – “Hybrid / Battery Control: Inverter With Converter: [Removal](#) / [Installation](#)”
 - 2011 Prius:
Engine/Hybrid System – Hybrid/Battery Control System – “Hybrid / Battery Control: Inverter With Converter: [Removal](#) / [Installation](#)”
 - 2012 Prius:
Engine/Hybrid System – Hybrid/Battery Control System – “Hybrid / Battery Control: Inverter With Converter: [Removal](#) / [Installation](#)”
 - 2013 Prius:
Engine/Hybrid System – Hybrid/Battery Control System – “Hybrid / Battery Control: Inverter With Converter: [Removal](#) / [Installation](#)”
 - 2014 Prius:
Engine/Hybrid System – Hybrid/Battery Control System – “Hybrid / Battery Control: Inverter With Converter: [Removal](#) / [Installation](#)”
 - 2015 Prius:
Engine/Hybrid System – Hybrid/Battery Control System – “Hybrid / Battery Control: Inverter With Converter: [Removal](#) / [Installation](#)”
 - 2012 Prius V:
Engine/Hybrid System – Hybrid/Battery Control System – “Hybrid / Battery Control: Inverter With Converter: [Removal](#) / [Installation](#)”

MIL ON With DTCs P0A94, P324E, P0A1A, and/or P3004

Repair Procedure (continued)

- 2013 Prius V:
Engine/Hybrid System – Hybrid/Battery Control System – “Hybrid / Battery Control: Inverter With Converter: [Removal](#) / [Installation](#)”
- 2014 Prius V:
Engine/Hybrid System – Hybrid/Battery Control System – “Hybrid / Battery Control: Inverter With Converter: [Removal](#) / [Installation](#)”
- 2015 Prius V:
Engine/Hybrid System – Hybrid/Battery Control System – “Hybrid / Battery Control: Inverter With Converter: [Removal](#) / [Installation](#)”
- 2016 – 2017 Prius V:
Engine/Hybrid System – Hybrid/Battery Control System – “Hybrid / Battery Control: Inverter With Converter: [Removal](#) / [Installation](#)”

A. The repair is now complete. Clear ANY DTCs and confirm the condition is no longer present.

3. Determine the correct components to replace based on the inverter assembly with converter type, DTC, and information code.

Refer to TIS, applicable model and model year Repair Manual:

- [2010](#) / [2011](#) / [2012](#) / [2013](#) / [2014](#) / [2015](#) Prius:
Engine/Hybrid System – Hybrid/Battery Control System – “Hybrid / Battery Control: Hybrid Control System: DTC Check / Clear”
- [2012](#) / [2013](#) / [2014](#) / [2015](#) / [2016](#) / [2017](#) Prius V:
Engine/Hybrid System – Hybrid/Battery Control System – “Hybrid / Battery Control: Hybrid Control System: DTC Check / Clear”

4. Repair the inverter assembly with converter.

NOTE

- ALL repairs in this Service Bulletin require super long life coolant, an inverter drain plug kit, and a gasket.
- Toyota thermal grease is ONLY used for IPM replacement. This part has a shelf life of one year. Do NOT use if stored past one year.
- Reference the [Quick Training Guide](#) for best practices for 2010 – 2015 model year Prius and 2012 – 2017 model year Prius V vehicles.

Refer to TIS, applicable model and model year Repair Manual:

- 2010 Prius:
Engine/Hybrid System – Hybrid/Battery Control System – “Hybrid / Battery Control: Power Module Intelligent Transistor: [Removal](#) / [Installation](#)”

MIL ON With DTCs P0A94, P324E, P0A1A, and/or P3004

Repair Procedure (continued)

- 2011 Prius:
Engine/Hybrid System – Hybrid/Battery Control System – “Hybrid / Battery Control: Power Module Intelligent Transistor: [Removal](#) / [Installation](#)”
- 2012 Prius:
Engine/Hybrid System – Hybrid/Battery Control System – “Hybrid / Battery Control: Power Module Intelligent Transistor: [Removal](#) / [Installation](#)”
- 2013 Prius:
Engine/Hybrid System – Hybrid/Battery Control System – “Hybrid / Battery Control: Power Module Intelligent Transistor: [Removal](#) / [Installation](#)”
- 2014 Prius:
Engine/Hybrid System – Hybrid/Battery Control System – “Hybrid / Battery Control: Power Module Intelligent Transistor: [Removal](#) / [Installation](#)”
- 2015 Prius:
Engine/Hybrid System – Hybrid/Battery Control System – “Hybrid / Battery Control: Power Module Intelligent Transistor: [Removal](#) / [Installation](#)”
- 2012 Prius V:
Engine/Hybrid System – Hybrid/Battery Control System – “Hybrid / Battery Control: Power Module Intelligent Transistor: [Disassembly](#) / [Reassembly](#)”
- 2013 Prius V:
Engine/Hybrid System – Hybrid/Battery Control System – “Hybrid / Battery Control: Power Module Intelligent Transistor: [Disassembly](#) / [Reassembly](#)”
- 2014 Prius V:
Engine/Hybrid System – Hybrid/Battery Control System – “Hybrid / Battery Control: Power Module Intelligent Transistor: [Disassembly](#) / [Reassembly](#)”
- 2015 Prius V:
Engine/Hybrid System – Hybrid/Battery Control System – “Hybrid / Battery Control: Power Module Intelligent Transistor: [Disassembly](#) / [Reassembly](#)”
- 2016 – 2017 Prius V:
Engine/Hybrid System – Hybrid/Battery Control System – “Hybrid / Battery Control: Power Module Intelligent Transistor: [Disassembly](#) / [Reassembly](#)”

5. Clear ANY DTCs and confirm the condition is no longer present.