

HVAC Servo Motor Malfunction

Service Category Vehicle Interior

Section Heating/Air Conditioning

Market USA

Lexus Supports
ASE Certification 

Applicability

YEAR(S)	MODEL(S)	ADDITIONAL INFORMATION
2016 - 2017	GS F, GS200T, IS200T, RC200T	
2013 - 2017	GS350	
2013 - 2017	GS450H	
2014 - 2015	IS250	
2016 - 2017	IS300, RC300	
2014 - 2017	IS350	
2015 - 2017	RC F	
2015 - 2017	RC350	

HVAC Servo Motor Malfunction

Introduction

Some 2013 – 2017 model year Lexus vehicles may exhibit one of the following HVAC conditions.

- Uneven temperature or air flow between the vents
- Little or no air flow from the vent(s)
- Improper MODE control function

Additionally, some vehicles may store one or more of the following HVAC servo Diagnostic Trouble Codes (DTCs).

- B1441 – Air Mix Damper Control Servo Motor Circuit (Front Passenger Side Lower Air Mix)
- B1442 – Air Inlet Damper Control Servo Motor Circuit
- B1443 – Air Outlet Damper Control Servo Motor Circuit
- B1446 – Air Mix Damper Control Servo Motor Circuit (Driver Side Lower Air Mix)
- B1447 – Rear Air Mix Damper Control Servo Motor Circuit
- B1448 – Passenger Side Face Servo Motor Circuit
- B1449 – Rear Air Outlet Damper Control Servo Motor Circuit
- B1453 – Driver Side Air Outlet Damper COOL Control Servo Motor Circuit
- B1454 – Passenger Side Air Outlet Damper COOL Control Servo Motor Circuit
- B1455 – Driver Side Air Outlet Damper FOOT/DEF Control Servo Motor Circuit

Follow the procedure in this bulletin to address this condition.

HVAC Servo Motor Malfunction

Operation Flowchart

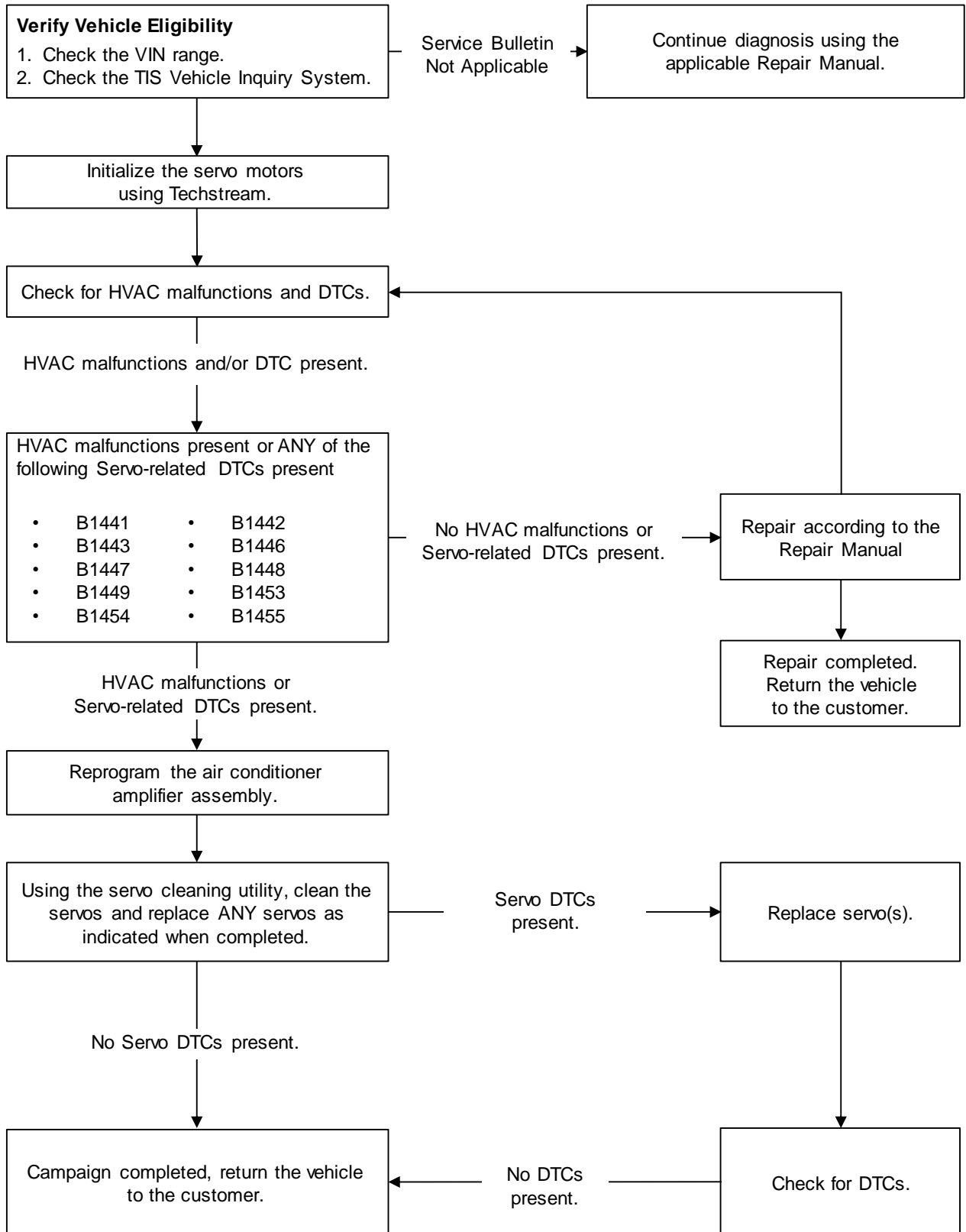

HVAC Servo Motor Malfunction

Procedures

- [Confirmation Procedure](#) 14
- [Flash Reprogram Procedure](#) 15
- [Servo Cleaning Process Procedure](#) 16
- Damper Servo Sub-assembly Replacement Procedure
 - [IS and RC Servo Location Guide](#)..... 20
 - [GS Servo Location Guide](#)..... 23
 - [Battery Disconnection](#) 26
 - Group A (Servo Replacement on Vehicle)
 - [\[4\] Air Outlet Servo \(P\) – DTC B1448 \(GS Only\)](#) 27
 - Group B (Servo Replacement on Vehicle)
 - [\[1\] Air Mix Servo \(D\) – DTC B1446 \(IS, RC, and GS\)](#) 31
 - [\[6\] Cool A/M Servo \(D\) – DTC B1453 \(IS, RC, and GS\)](#) 36
 - [\[8\] A/O Servo \(Rr D\) – DTC B1449 \(GS Only\)](#) 41
 - Group C (Servos Replaced From A/C Unit Removed From Vehicle)
 - [\[2\] Air Mix Servo \(P\) – DTC B1441 \(IS, RC, and GS\)](#) 47
 - [\[9\] Rear Air Mix Servo – DTC B1447 \(GS Only\)](#) 47
 - [\[7\] Cool A/M Servo \(P\) – DTC B1454 \(IS, RC, and GS\)](#)..... 53
 - [\[5\] Air Inlet Damper Servo – DTC B1442 \(IS, RC, and GS\)](#) 58
 - [3] Air Outlet Servo (D) – DTC B1443 (IS, RC, and GS)
 - [\(1\) With Lever Type \(IS and RC\)](#)..... 63
 - [\(2\) Without Lever Type \(GS\)](#)..... 70
 - [\[10\] DEF A/O Servo \(D\) – DTC B1455 \(IS, RC, and GS\)](#)..... 73
- [Completion Procedure](#) 77

HVAC Servo Motor Malfunction

Production Change Information

This bulletin applies to the following vehicles:

- All 2014 – 2015 IS250 vehicles.
- 2014 – 2017 IS200t, IS300, and IS350 vehicles produced **BEFORE** the Production Change Effective VINs shown below.
- 2015 – 2017 RC200t, RC300, and RC350 vehicles produced **BEFORE** the Production Change Effective VINs shown below.
- 2015 – 2017 RC F vehicles produced **BEFORE** the Production Change Effective VIN shown below.
- 2013 – 2017 GS200t and GS 350 vehicles produced **BEFORE** the Production Change Effective VINs shown below.
- 2013 – 2017 GS450h vehicles produced **BEFORE** the Production Change Effective VIN shown below.
- 2016 – 2017 GS F vehicles produced **BEFORE** the Production Change Effective VINs shown below.

MODEL	DRIVETRAIN	FRAME TYPE	PRODUCTION CHANGE EFFECTIVE VIN
IS200t	2WD	ASE30L	JTHBA1D2#H5056884
IS300	AWD	GSE37L	JTHCM1D2#H5024594
IS350	2WD	GSE31L	JTHBE1D2#H5030855
	AWD	GSE36L	JTHCE1D2#H5014302
RC200t	2WD	ASC10L	JTHHA5BC#H5006941
RC350		GSC10L	JTHHE5BC#H5017147
RC300	AWD	GSC15L	JTHSE5BC#H5008146
RC F		GSC16L	JTHSM5BC#H5003560
GS200t	2WD	USC10L	JTHHP5BC#H5006678
GS350		ARL10L	JTHBA1BL#HA005701
		GRL12L	JTHBZ1BL#HA011922
GS450h	AWD	GRL16L	JTHCZ1BL#HA007257
GS F		2WD	GWL10L
		URL10L	JTHBP1BL#HA002488

HVAC Servo Motor Malfunction

Warranty Information

Table 1. All Models – Inspection and Reprogramming

OP CODE	DESCRIPTION	TIME	OFF	T1	T2
ZKL001	Reprogram and Redistribute Grease	0.7	88650-#####*	72	41

Table 2. Servo Replacement on Vehicle

OP CODE	DESCRIPTION	MODEL	GROUP	TIME	OFF	T1	T2
ZKL002	R & R Glove Compartment Door, Air Conditioner Amplifier, and One Servo	GS	A	1.4	87106-#####*	72	41
ZKL003	R & R Driver Knee Airbag and One Servo			IS / RC			
ZKL004		1.3					
ZKL005	R & R Driver Knee Airbag and Two Servos	GS	B	1.4			
ZKL006		IS / RC		1.4			
ZKL007	R & R Driver Knee Airbag and Three Servos	GS	A and B	1.5			
ZKL008	R & R Glove Compartment Door, Air Conditioner Amplifier, One Servo, and R & R Driver Knee Airbag and One Servo			1.9			
ZKL009	R & R Glove Compartment Door, Air Conditioner Amplifier, One Servo, and R & R Driver Knee Airbag and Two Servos			2.0			
ZKL010	R & R Glove Compartment Door, Air Conditioner Amplifier, One Servo, and R & R Driver Knee Airbag and Three Servos			2.1			

*Warranty claim MUST be submitted with the correct ten-digit OFF. Choose the correct OFF for the vehicle being repaired by searching Air Conditioning, Amplifier (88650) and Servo Sub-Assy, Damper (87106) in the Electronic Parts Catalog using the VIN filter.

HVAC Servo Motor Malfunction

Warranty Information (continued)

Table 3. Servo Motor Replacement From Air Conditioner Unit Removed From Vehicle

OP CODE	DESCRIPTION	MODEL	GROUP	TIME	OFFP	T1	T2
ZKL011	Air Conditioner Box Removal and R & R One Servo	GS	C	7.6	87106-#####*	72	41
ZKL012		IS / RC		6.5			
ZKL013	Air Conditioner Box Removal and R & R Two Servos	GS		7.7			
ZKL014		IS / RC		6.6			
ZKL015	Air Conditioner Box Removal and R & R Three Servos	GS		7.8			
ZKL016		IS / RC		6.7			
ZKL017	Air Conditioner Box Removal and R & R Four Servos	GS		7.9			
ZKL018		IS / RC		6.8			
ZKL019	Air Conditioner Box Removal and R & R Five Servos	GS		8.0			
ZKL020		IS / RC		6.9			
ZKL021	Air Conditioner Box Removal and R & R Six Servos	GS		8.1			
ZKL022		IS / RC		7.0			
ZKL023	Air Conditioner Box Removal and R & R Seven Servos	GS		8.2			
ZKL024		IS / RC		7.1			
ZKL025	Air Conditioner Box Removal and R & R Eight Servos	GS		8.3			
ZKL026	Air Conditioner Box Removal and R & R Nine Servos	GS		8.4			

*Warranty claim MUST be submitted with the correct ten-digit OFFP. Choose the correct OFFP for the vehicle being repaired by searching Air Conditioning, Amplifier (88650) and Servo Sub-Assy, Damper (87106) in the Electronic Parts Catalog using the VIN filter.

HVAC Servo Motor Malfunction

Warranty Information (continued)

APPLICABLE WARRANTY

- This repair is covered under the Lexus Basic Warranty. This warranty is in effect for 48 months or 50,000 miles, whichever occurs first, from the vehicle's in-service date.
- Warranty application is limited to occurrence of the specified condition described in this bulletin.

Parts Information

Table 4. IS Models

SERVO NAME / DTC	PART NUMBER	PART NAME	QTY	NOTES	
[1] Air Mix Servo (D) / B1446	87106-30570	Damper Servo Sub-Assy, Air Conditioner Radiator, No. 5	0 – 1	-	
[2] Air Mix Servo (P) / B1441	87106-30550	Damper Servo Sub-Assy, Air Conditioner Radiator, No. 4	0 – 1		
[3] Air Outlet Servo (D) / B1443	87106-30540	Damper Servo Sub-Assy, Air Conditioner Radiator, No. 3	0 – 1		
	87296-53010	Lever, Heater Air Damper Control	0 – 1		
[5] Air Inlet Damper Servo / B1442	87106-30510	Damper Servo Sub-Assy, Blower, No.1	0 – 1		
	87296-53020	Lever, Heater Air Damper Control	0 – 1		
[6] Cool A/M Servo (D) / B1453	87106-30530	Damper Servo Sub-Assy, Air Conditioner Radiator, No. 2	0 – 1		4/2013 – 6/2014
	87106-30610		0 – 1		6/2014 –
[7] Cool A/M Servo (P) / B1454	87106-30530	Damper Servo Sub-Assy, Air Conditioner Radiator, No. 2	0 – 1		4/2013 – 6/2014
	87106-30610		0 – 1		6/2014 –
[10] DEF A/O Servo (D) / B1455	87106-30500	Damper Servo Sub-Assy, Air Conditioner Radiator, No. 1	0 – 1	-	

HVAC Servo Motor Malfunction

Parts Information (continued)

Table 5. RC and RC F Models

SERVO NAME / DTC	PART NUMBER	PART NAME	QTY
[1] Air Mix Servo (D) / B1446	87106-30570	Damper Servo Sub-Assy, Air Conditioner Radiator, No. 5	0 – 1
[2] Air Mix Servo (P) / B1441	87106-30550	Damper Servo Sub-Assy, Air Conditioner Radiator, No. 4	0 – 1
[3] Air Outlet Servo (D) / B1443	87106-30540	Damper Servo Sub-Assy, Air Conditioner Radiator, No. 3	0 – 1
	87296-53010	Lever, Heater Air Damper Control	0 – 1
[5] Air Inlet Damper Servo / B1442	87106-30510	Damper Servo Sub-Assy, Blower, No. 1	0 – 1
	87296-53020	Lever, Heater Air Damper Control	0 – 1
[6] Cool A/M Servo (D) / B1453	87106-30610	Damper Servo Sub-Assy, Air Conditioner Radiator, No. 2	0 – 1
[7] Cool A/M Servo (P) / B1454	87106-30610		0 – 1
[10] DEF A/O Servo (D) / B1455	87106-30500	Damper Servo Sub-Assy, Air Conditioner Radiator, No. 1	0 – 1

HVAC Servo Motor Malfunction

Parts Information (continued)

Table 6. GS and GS HV Models

SERVO NAME / DTC	PART NUMBER	PART NAME	QTY	NOTES
[1] Air Mix Servo (D) / B1446	87106-30570	Damper Servo Sub-Assy, Air Conditioner Radiator, No. 4	0 – 1	–
[2] Air Mix Servo (P) / B1441	87106-30550	Damper Servo Sub-Assy, Air Conditioner Radiator, No. 3	0 – 1	Except Version L (One Servo)
	87106-30560		0 – 1	Version L (Two Servos)
[3] Air Outlet Servo (D) / B1443	87106-30590	Damper Servo Sub-Assy, Air Conditioner Radiator, No. 6	0 – 1	–
[4] Air Outlet Servo (P) / B1448	87106-30580	Damper Servo Sub-Assy, Air Conditioner Radiator, No. 5	0 – 1	
[5] Air Inlet Damper Servo / B1442	87106-30510	Damper Servo Sub-Assy, Blower, No. 1	0 – 1	
	87296-53020	Lever, Heater Air Damper Control	0 – 1	
[6] Cool A/M Servo (D) / B1453	87106-30530	Damper Servo Sub-Assy, Air Conditioner Radiator, No. 2	0 – 1	
	87106-30610		0 – 1	5/2014 –
[7] Cool A/M Servo (P) / B1454	87106-30530		0 – 1	12/2011 – 5/2014
	87106-30610		0 – 1	5/2014 –
[8] A/O Servo (Rr D) / B1449	87106-30600	Damper Servo Sub-Assy, Air Conditioner Radiator, No. 7	0 – 1	12/2011 – 5/2014
	87106-30620		0 – 1	5/2014 –
[9] Rear Air Mix Servo / B1447	87106-30560	Damper Servo Sub-Assy, Air Conditioner Radiator, No. 3	0 – 1	Version L (Two Servos)
[10] DEF A/O Servo (D) / B1455	87106-30500	Damper Servo Sub-Assy, Air Conditioner Radiator, No.1	0 – 1	–

HVAC Servo Motor Malfunction

Parts Information (continued)

Table 7. GS F Models

SERVO NAME / DTC	PART NUMBER	PART NAME	QTY	NOTES
[1] Air Mix Servo (D) / B1446	87106-30570	Damper Servo Sub-Assy, Air Conditioner Radiator, No. 4	0 – 1	-
[2] Air Mix Servo (P) / B1441	87106-30550	Damper Servo Sub-Assy, Air Conditioner Radiator, No. 3	0 – 1	
	87106-30560		0 – 1	
[3] Air Outlet Servo (D) / B1443	87106-30590	Damper Servo Sub-Assy, Air Conditioner Radiator, No. 6	0 – 1	
[4] Air Outlet Servo (P) / B1448	87106-30580	Damper Servo Sub-Assy, Air Conditioner Radiator, No. 5	0 – 1	
[5] Air Inlet Damper Servo / B1442	87106-30510	Damper Servo Sub-Assy, Blower, No. 1	0 – 1	
	87296-53020	Lever, Heater Air Damper Control	0 – 1	
[6] Cool A/M Servo (D) / B1453	87106-30610	Damper Servo Sub-Assy, Air Conditioner Radiator, No. 2	0 – 1	
[7] Cool A/M Servo (P) / B1454	87106-30610		0 – 1	
[8] A/O Servo (Rr D) / B1449	87106-30620	Damper Servo Sub-Assy, Air Conditioner Radiator, No. 7	0 – 1	
			0 – 1	
[9] Rear Air Mix Servo / B1447	87106-30560	Damper Servo Sub-Assy, Air Conditioner Radiator, No. 3	0 – 1	Seat Heater With Driver, Passenger, and Rear and Cooler
[10] DEF A/O Servo (D) / B1455	87106-30500	Damper Servo Sub-Assy, Air Conditioner Radiator, No.1	0 – 1	-

HVAC Servo Motor Malfunction

Parts Information (continued)

Table 8. Group C – Additional Ancillary Parts

MODEL	PART NUMBER	PART DESCRIPTION	QTY	NOTES
All	90099-14119	O-ring	0 – 1	Evaporator O-ring
	90099-14121		0 – 1	

Required Tools & Equipment

SPECIAL SERVICE TOOLS (SST)	PART NUMBER	QTY
Plastic Pry Tool Kit*	00002-06020-02	1
DCA-8000 Battery Diagnostic Tool*	DCA-8000P T	1

*Essential SST.

NOTE

Additional SSTs may be ordered by calling 1-800-933-8335.

REQUIRED EQUIPMENT	SUPPLIER	PART NUMBER	QTY
Techstream ADVi*	ADE	TSADVUNIT	1
Techstream 2.0		TS2UNIT	
Techstream Lite		TSLITEPDLR01	
Techstream Lite (Green Cable)		TSLP2DLR01	

*Essential SST.

NOTE

- Only ONE of the Techstream units listed above is required.
- Software version 15.30.027 or later is required.
- Additional Techstream units may be ordered by calling Approved Dealer Equipment (ADE) at 1-800-368-6787.

HVAC Servo Motor Malfunction

Calibration Information

MODEL	MODEL YEAR	CALIBRATION ID	
		PREVIOUS	NEW
IS	2014	886505340004	886505363001
		886505340006	
	2015	886505340101	886505367001
	2016	886505340201	886505371001
RC	2017	886505340301	886505379001
	2015	886505340101	886505367001
	2016	886505340201	886505371001
RC F	2017	886505340301	886505379001
	2015	886505340101	886505367001
	2016	886505340201	886505371001
GS	2013	8865030P6012	886503AE0001
		8865030P6013	
		8865030P6014	
	2014	8865030U8002	886503AY4001
	2015	886503A35002	886503F15001
	2016	886503A52002	886503F39001
	2017	886503AM1000	
GS HV	2013	8865030D4012	886503AZ2001
		8865030D4013	
	2014	8865030U0002	886503F07001
	2015	8865030Z7002	886503F23001
	2016	886503A39002	886503FA2001
	2017	886503AL3000	
GS F	2016	886503A52002	886503F39001
	2017	886503AM1000	

HVAC Servo Motor Malfunction

Confirmation Procedure

1. Confirm the following conditions.
 - Uneven temperature or air flow between the vents
 - Little or no air flow from vent(s)
 - Improper MODE control function

Does the vehicle exhibit ANY of the conditions listed above?

- **YES** —Continue to the Flash Reprogram Procedure subsection.
- **NO** — Continue to step 2.

2. Using Techstream, check for the following stored DTCs.
 - B1441 – Air Mix Damper Control Servo Motor Circuit (Front Passenger Side Lower Air Mix)
 - B1442 – Air Inlet Damper Control Servo Motor Circuit
 - B1443 – Air Outlet Damper Control Servo Motor Circuit
 - B1446 – Air Mix Damper Control Servo Motor Circuit (Driver Side Lower Air Mix)
 - B1447 – Rear Air Mix Damper Control Servo Motor Circuit
 - B1448 – Passenger Side Face Servo Motor Circuit
 - B1449 – Rear Air Outlet Damper Control Servo Motor Circuit
 - B1453 – Driver Side Air Outlet Damper COOL Control Servo Motor Circuit
 - B1454 – Passenger Side Air Outlet Damper COOL Control Servo Motor Circuit
 - B1455 – Driver Side Air Outlet Damper FOOT/DEF Control Servo Motor Circuit

Are ANY of the DTCs listed above present?

- **YES** — Continue to the Flash Reprogram Procedure subsection.
- **NO** — This bulletin does NOT apply. Continue diagnosis using the applicable Repair Manual.

HVAC Servo Motor Malfunction

Flash Reprogramming Procedure

Flash reprogram the air conditioning amplifier assembly.

NOTE

The air conditioning amplifier flash reprogram is only performed one time if the air conditioning amplifier has NOT been flash reprogrammed previously.

Follow the procedure outlined in Service Bulletin [L-SB-0001-18](#), *Techstream ECU Flash Reprogramming Procedure* and flash the air conditioning amplifier with the NEW calibration file update.

NOTE

The battery diagnostic tool MUST be used in Power Supply Mode to maintain battery voltage above 11.4V while flash reprogramming the air conditioner amplifier.

NOTICE

- **Damage to the air conditioning amplifier may occur if the correct battery charge mode setting is NOT used.**
- **Power Supply Mode is used to maintain battery voltage at 13.5V while flash reprogramming.**
- **For details on how to use the battery diagnostic tool, refer to the [DCA-8000 Battery Diagnostic Tool Instruction Manual](#) located on *TIS – Diagnostics – Tools & Equipment – Battery Diagnostics*.**

HVAC Servo Motor Malfunction

Servo Cleaning Process Procedure

1. Clean the servos using the AC damper operation check tool.
 - A. Continue with the battery diagnostic tool connected using the "Power Supply Mode" ONLY.
 - B. Confirm flash reprogramming of the air conditioning amplifier is complete otherwise the AC damper servo operation check tool will show the corresponding error message.

NOTE

The AC damper servo operation check tool will ONLY function correctly with the NEW calibration file update.

Figure 1.

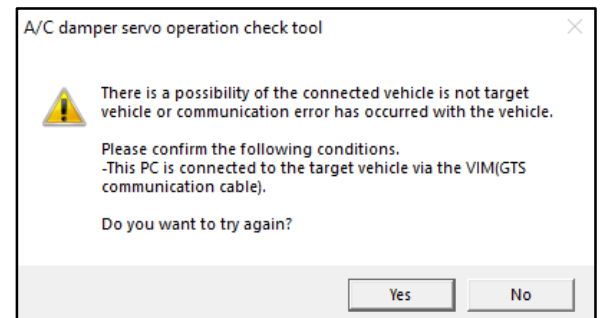

- C. BEFORE using the AC damper servo operation check tool, manually set the front and rear air conditioning to the following setting:
 - MODE – Face
 - Temperature – Max Cold
 - Air Inlet – Recirculation
- D. Download the AC damper servo operation check tool onto the Techstream desktop.
 - (1) Select the following link to download the AC damper servo operation check tool to Techstream:

[AC damper servo operation check tool download](#)

NOTE

Depending on browser and settings used, the file may not automatically save to the Techstream desktop. If this is the case, locate the downloaded file and save it to the Techstream desktop.

- E. Confirm the ignition is in the IG-ON position and the Techstream is connected to the DLC3 connector.
- F. Confirm NO other programs on the Techstream are currently communicating with the vehicle.
- G. Double-click on the AC damper servo operation check tool from the Techstream desktop.

HVAC Servo Motor Malfunction

Servo Cleaning Process Procedure (continued)

- H. Click on “NEXT” to start the AC damper servo operation check tool and the progress bar will show. It will take between 8 – 14 minutes to complete the cleaning process depending on the condition of the servos. The completion rate of the progress bar will show between 50% – 100%.

NOTE

If the connection between Techstream and the vehicle is interrupted during the cleaning process, the error message in Figure 2 will also display. To reconnect, turn OFF the Techstream unit and disconnect it from the DLC3 connector, reconnect Techstream and confirm connections, and turn ON the Techstream unit and restart the cleaning process.

Figure 2.

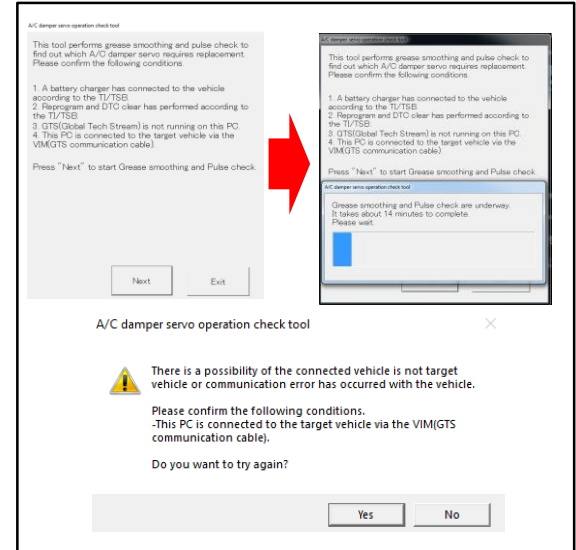

- I. When the cleaning process is completed, the DTC check result screen shown below will be displayed. If any DTC is output, the servo related to it will require replacement (Reference the Servo Location Guides on pages 20 – 25 for the servo motor location).

NOTE

If DTC B1497 or B149A is output, this bulletin does NOT apply. The communication from the air conditioning amplifier to each servo has an error or a communication interruption. Complete sub steps I and J and continue diagnosis using the applicable Repair Manual.

HVAC Servo Motor Malfunction

Servo Cleaning Process Procedure (continued)

Are any DTCs output?

- **YES** — Check DTC and Servo Location Guide and replace the appropriate servo according to the displayed DTC (Figure 3).
- **NO** — Complete substeps J – K to complete the repair and return the vehicle to the customer (Figure 4).

Figure 3.

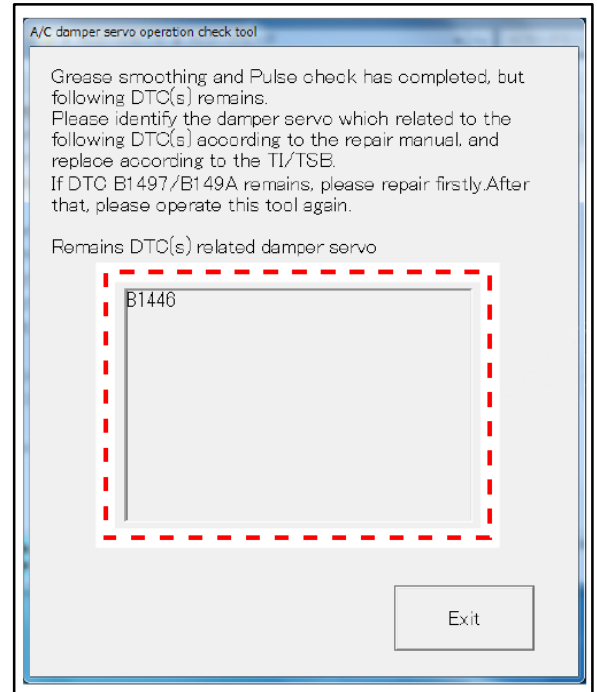
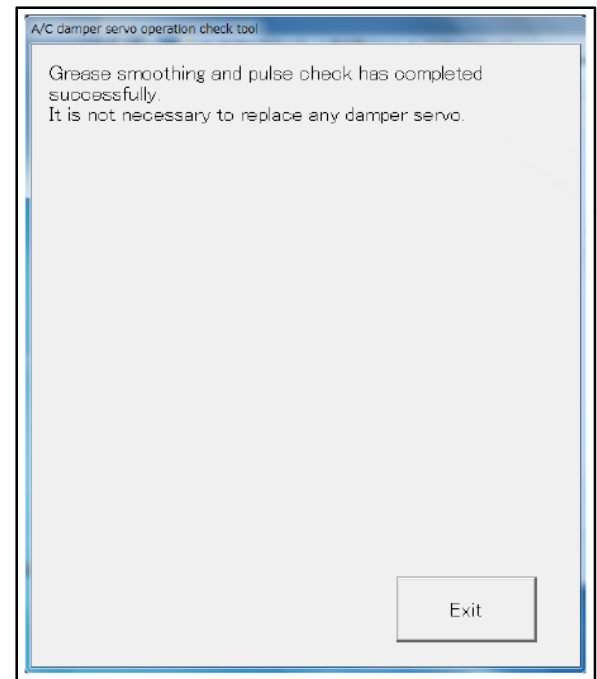

Figure 4.



HVAC Servo Motor Malfunction

Servo Cleaning Process Procedure (continued)

- J. Take a screen shot of the VIN displayed on the Techstream System Selection Menu overlaid with the AC damper servo operation check tool results showing the DTCs. Retain the screen shot as per Toyota Warranty Policies and Procedures with the repair order.

Figure 5.

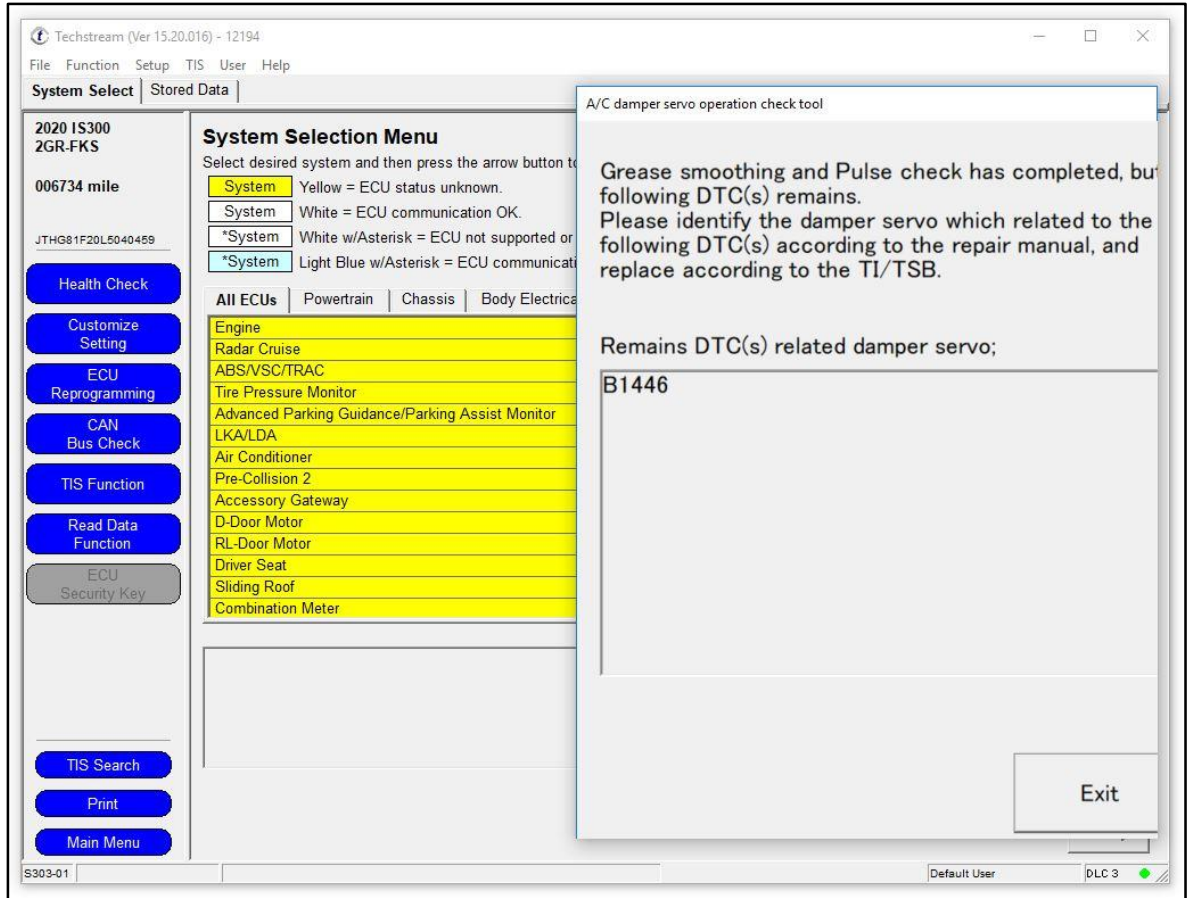

- K. The Servo Cleaning Operation is complete. Cycle the ignition to the IG-OFF position and select Exit.
- L. Turn OFF and disconnect the battery diagnostic tool.

HVAC Servo Motor Malfunction

Damper Servo Sub-assembly Replacement Procedure

NOTE

The servo replacement procedure (and removal of surrounding parts) varies depending on the servo to be replaced. Perform the replacement procedures according to the IS, RC, and GS Servo Location Guides.

IS and RC Servo Location Guide

Required Removal Work for Replacement of Each Servo

Figure 6. Servo Replacement on Vehicle

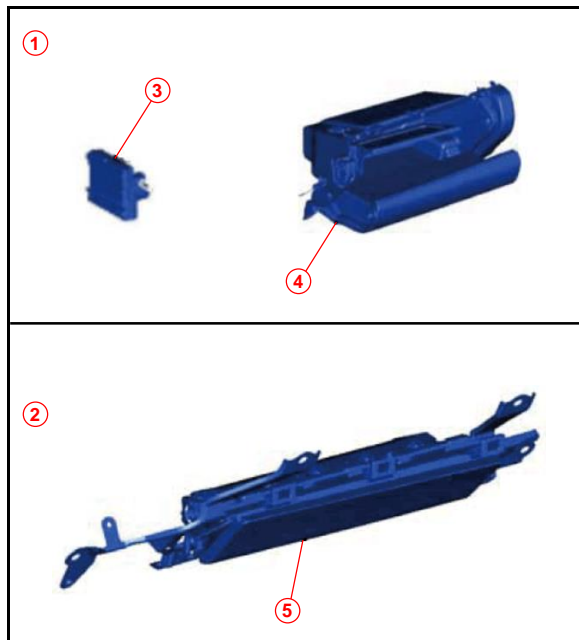

1	Group A
2	Group B
3	Air Conditioning Amplifier
4	Glove Compartment Door Assembly
5	Lower No. 1 Instrument Panel Airbag Assembly

Figure 7. Servos Replaced From Air Conditioning Unit Removed From Vehicle

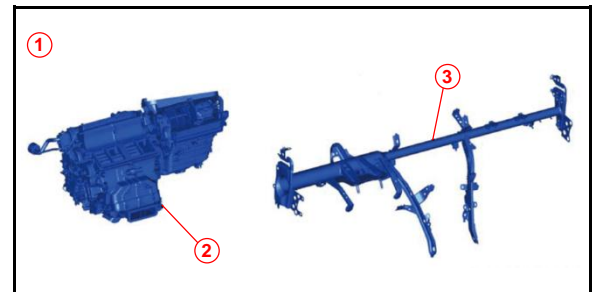

1	Group C
2	Air Conditioning Unit
3	Instrument Panel Reinforcement Assembly

- Groups A and B Servo Replacement:
Servo replacement takes place on the vehicle.
- Group C Servo Replacement:
To access the servos, servo replacement requires removal of the air conditioning unit from the vehicle.
If multiple servos need to be replaced that require Group C procedure, performing procedures for Groups A and B will NOT be necessary.

HVAC Servo Motor Malfunction

Damper Servo Sub-assembly Replacement Procedure (continued)

IS and RC Servo Location Guide (continued)

No.	DTC	PART NUMBER	ACTIVE TEST ITEMS	MODEL		GROUP			PG.
				IS	RC	A	B	C	
[1]	B1446	87106-30570	Air Mix Servo Targ Pulse (D)	•	•	–	•	–	31
[2]	B1441	87106-30550	Air Mix Servo Targ Pulse (P)	•	•	–	–	•	47
[3]	B1443	87106-30540	Air Outlet Servo Pulse (D)	•	•	–	–	•	W/Lever: 63
[4]	B1448	–	–	–	–	–	–	–	–
[5]	B1442	87106-30510	Air Inlet Damper Targ Pulse	•	•	–	–	•	58
[6]	B1453	87106-30530 (4/2013 - 6/2014)	Cool A/M Servo Pulse (D)	•	–	–	•	–	36
		87106-30610 (6/2014 -)		•	•	–	•	–	
[7]	B1454	87106-30530 (4/2013 - 6/2014)	Cool A/M Servo Pulse (P)	•	–	–	–	•	53
		87106-30610 (6/2014 -)		•	•	–	–	•	
[10]	B1455	87106-30500	DEF A/O Servo Pulse (D)	•	•	–	–	•	73

HVAC Servo Motor Malfunction

Damper Servo Sub-assembly Replacement Procedure (continued)

IS and RC Servo Location Guide (continued)

Figure 8. IS and RC Servo Motors

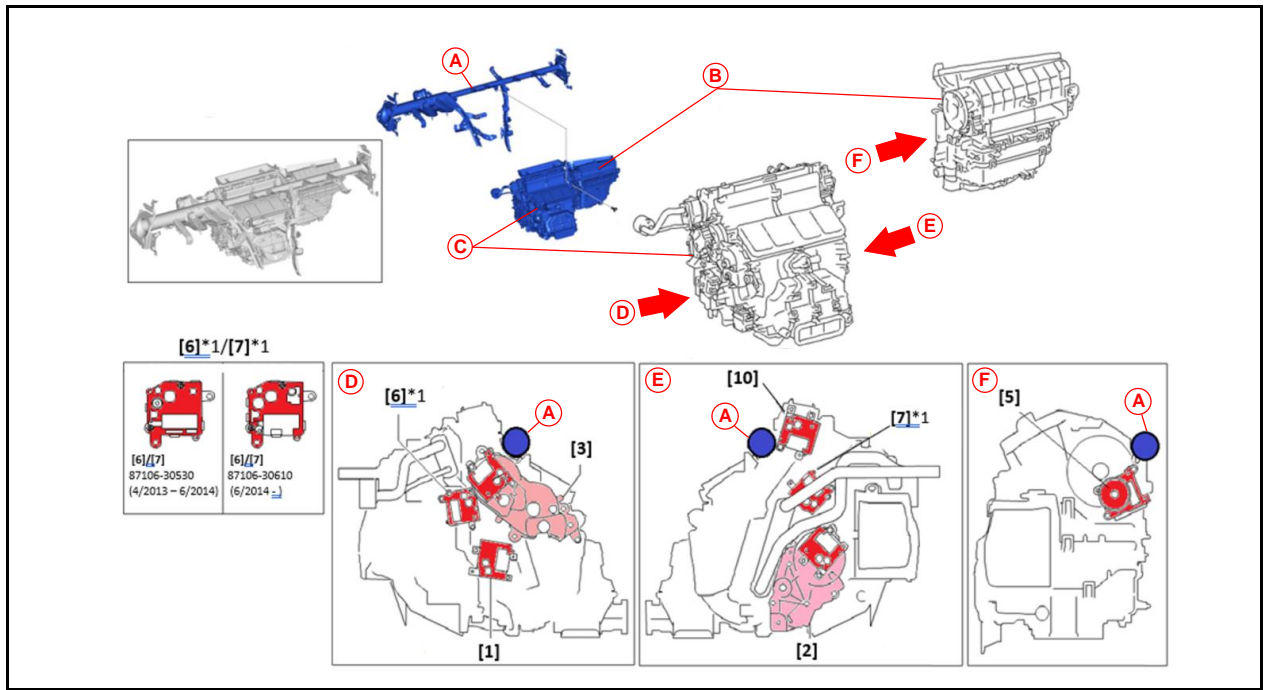

A	I/P Reinforcement Assembly
B	Blower Assembly
C	Air Conditioning Radiator Assembly

D	Air Conditioner (Left-hand View)
E	Air Conditioner (Right-hand View)
F	Blower (Left-hand View)

HVAC Servo Motor Malfunction

Damper Servo Sub-assembly Replacement Procedure (continued)

NOTE

The servo replacement procedure (and removal of surrounding parts) varies depending on the servo to be replaced. Perform the replacement procedures according to the IS, RC, and GS Servo Location Guides.

GS Servo Location Guide

Required Removal Work for Replacement of Each Servo

Figure 9. Servo Replacement on Vehicle

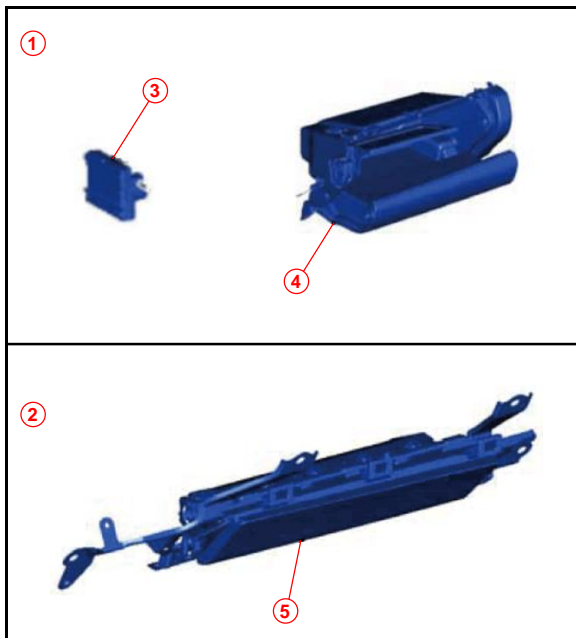

1	Group A
2	Group B
3	Air Conditioning Amplifier
4	Glove Compartment Door Assembly
5	Lower No. 1 Instrument Panel Airbag Assembly

Figure 10. Servos Replaced From Air Conditioning Unit Removed From Vehicle

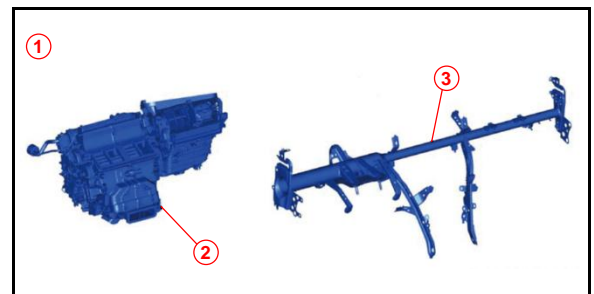

1	Group C
2	Air Conditioning Unit
3	Instrument Panel Reinforcement Assembly

- Groups A and B Servo Replacement:
Servo replacement takes place on the vehicle.
- Group C Servo Replacement:
To access the servos, servo replacement requires removal of the air conditioning unit from the vehicle.
If multiple servos need to be replaced that require Group C procedure, performing procedures for Groups A and B will NOT be necessary.

HVAC Servo Motor Malfunction

Damper Servo Sub-assembly Replacement Procedure (continued)

GS Servo Location Guide (continued)

No.	DTC	PART NUMBER	ACTIVE TEST ITEMS	MODEL		GROUP			Pg.
				GS	GS F	A	B	C	
[1]	B1446	87106-30570	Air Mix Servo Targ Pulse (D)	•	•	–	•	–	31
[2]	B1441	87106-30550	Air Mix Servo Targ Pulse (P)	•	•	–	–	•	47
		87106-30560		•	•	–	–	•	
[3]	B1443	87106-30590	Air Outlet Servo Pulse (D)	•	•	–	–	•	W/O Lever: 70
[4]	B1448	87106-30580	Air Outlet Servo Pulse (P)	•	•	•	–	–	27
[5]	B1442	87106-30510	Air Inlet Damper Targ Pulse	•	•	–	–	•	58
[6]	B1453	87106-30530	Cool A/M Servo Pulse (D)	•	–	–	•	–	36
		87106-30610		•	•	–	•	–	
[7]	B1454	87106-30530	Cool A/M Servo Pulse (P)	•	–	–	–	•	53
		87106-30610		•	•	–	–	•	
[8]	B1449	87106-30600	A/O Servo Pulse (Rr D)	•	–	–	•	–	41
		87106-30620		•	•	–	•	–	
[9]	B1447	87106-30560	Rear Air Mix Servo Targ Pulse	•	•	–	–	•	47
[10]	B1455	87106-30500	DEF A/O Servo Pulse (D)	•	•	–	–	•	73

HVAC Servo Motor Malfunction

Damper Servo Sub-assembly Replacement Procedure (continued)

GS Servo Location Guide (continued)

Figure 11. GS Servo Motors

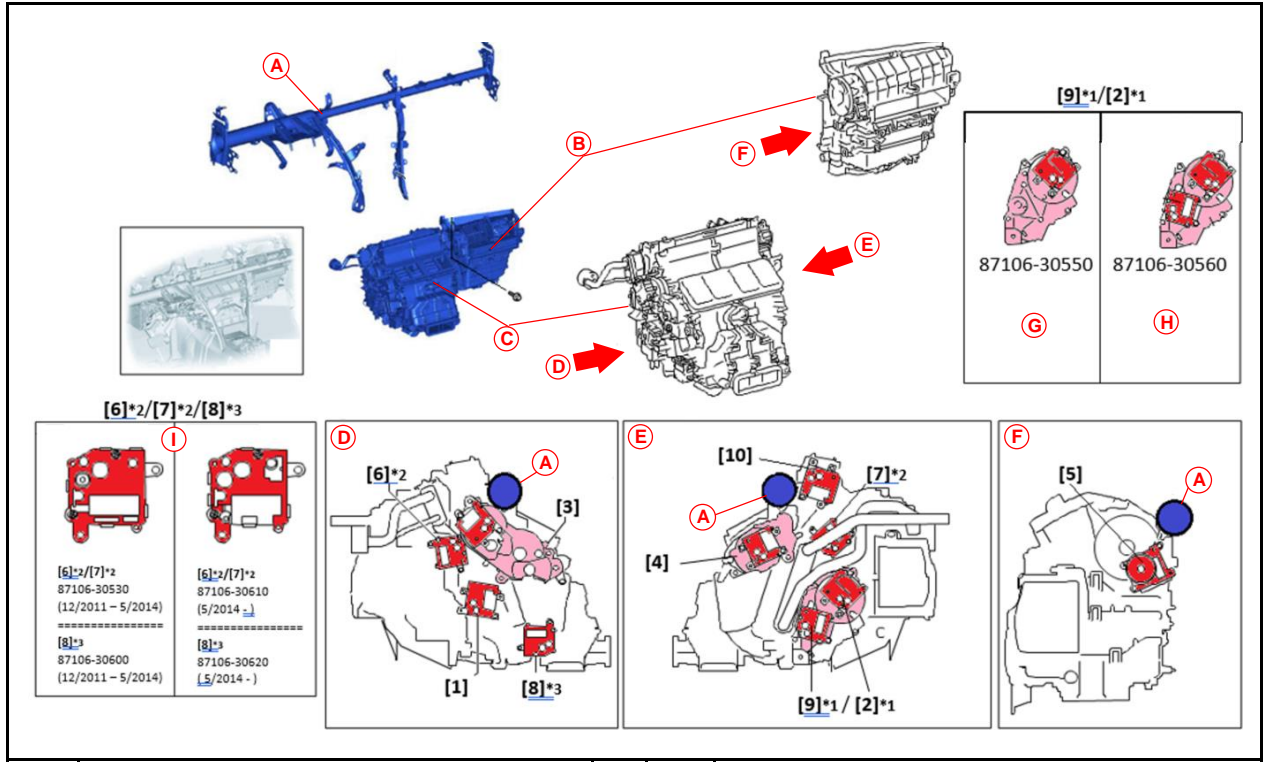

A	I/P Reinforcement Assembly
B	Blower Assembly
C	Air Conditioning Radiator Assembly
D	Air Conditioner (Left-hand View)
E	Air Conditioner (Right-hand View)

F	Blower (Left-hand View)
G	Except Version L (One Servo)
H	Version L (Two Servos)
I	Reference Image Only

HVAC Servo Motor Malfunction

Damper Servo Sub-assembly Replacement Procedure (continued)

Battery Disconnection

1. Disconnect the battery.

Refer to TIS, applicable model and model year Repair Manual:

Vehicle Interior – Supplemental Restraint Systems – “Supplemental Restraint Systems: Knee Airbag Assembly (for Driver Side): Removal”

- IS200T: [2016](#) / [2017](#)
- IS250: [2014](#) / [2015](#)
- IS300: [2016](#) / [2017](#)
- IS350: [2014](#) / [2015](#) / [2016](#) / [2017](#)
- RC200T: [2016](#) / [2017](#)
- RC300: [2016](#) / [2017](#)
- RC350: [2015](#) / [2016](#) / [2017](#)
- RC F: [2015](#) / [2016](#) / [2017](#)
- GS200T: [2016](#) / [2017](#)
- GS350: [2013](#) / [2014](#) / [2015](#) / [2016](#) / [2017](#)
- GS450H: [2013](#) / [2014](#) / [2015](#) / [2016](#) / [2017](#)
- GS F: [2016](#) / [2017](#)

HVAC Servo Motor Malfunction

Damper Servo Sub-assembly Replacement Procedure (continued)

Replacement Procedure Group A (Servo Replacement on Vehicle)

NOTE

If there are currently servos requiring replacement that are BOTH in Group A and in Group C, perform the air conditioning unit removal steps from Group C (pg. 47; Step 1A) first, then follow the servo replacement steps from Group A to replace the Group A servo. Replace ALL Group A and Group C servo(s) BEFORE reinstalling the air conditioning unit.

[4] Air Outlet Servo (P) – DTC B1448 (GS ONLY)

1. Remove the glove compartment door assembly and air conditioning amplifier (passenger side).

Refer to TIS, applicable model and model year Repair Manual:

Vehicle Interior –

Heating/Air Conditioning –

“Heating / Air Conditioning: Air Conditioning Amplifier: Removal”

- GS200T: [2016](#) / [2017](#)
- GS350: [2013](#) / [2014](#) / [2015](#) / [2016](#) / [2017](#)
- GS450H: [2013](#) / [2014](#) / [2015](#) / [2016](#) / [2017](#)
- GS F: [2016](#) / [2017](#)

Figure 12.

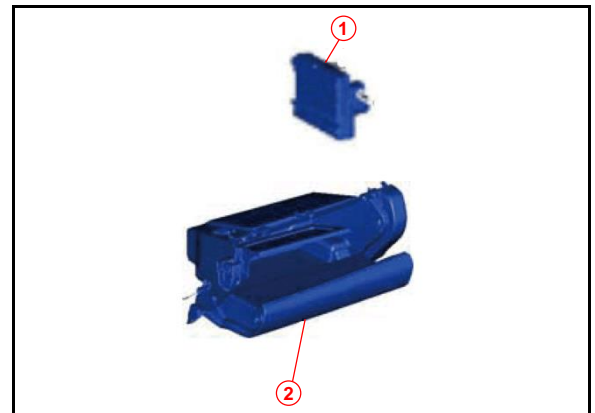

1	Air Conditioning Amplifier
2	Glove Compartment Door Assembly

HVAC Servo Motor Malfunction

Damper Servo Sub-assembly Replacement Procedure (continued)

Replacement Procedure Group A (Servo Replacement on Vehicle) (continued)

2. Disconnect the two connectors.

Figure 13.

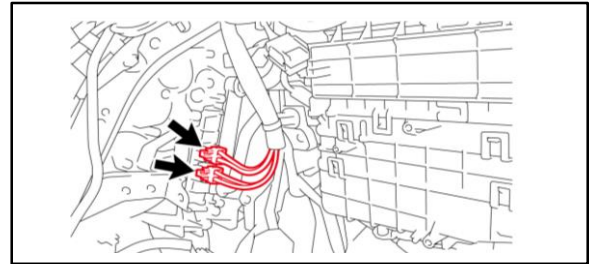

3. Disconnect the connector from the servo.

4. Remove the three screws and the servo module.

NOTE
Do NOT remove the screws installed on the servo body.

Figure 14.

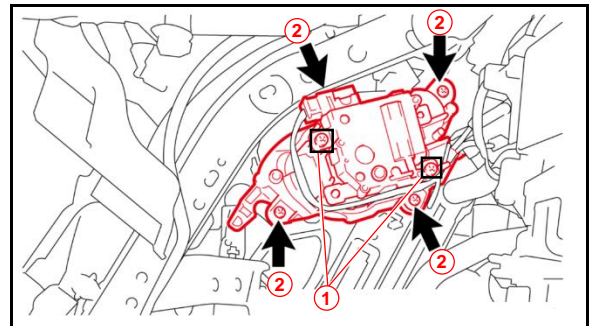

1	Do Not Remove
2	Remove

5. Mark and store the removed servo in a separate container to avoid reinstalling it in error.

NOTE
Reuse the attaching screws. If a screw is missing, order part number 90099-00968.

HVAC Servo Motor Malfunction

Damper Servo Sub-assembly Replacement Procedure (continued)

Replacement Procedure Group A (Servo Replacement on Vehicle) (continued)

6. Install the NEW air outlet servo (P). Align the missing tooth part of the gear with the corresponding mark on the case, then position the lever between the two marks.

CAUTION
Be careful of the lever position as it may move due to the weight of the door.

Figure 15.

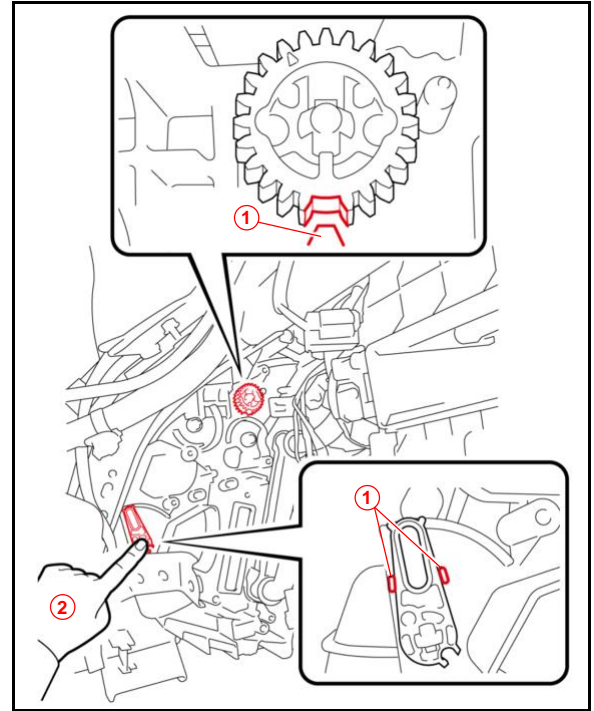

1	Mark
2	Hold

7. Temporarily install the NEW servo while adjusting the positions of the gear and lever.
8. Confirm that the pin of the servo is inserted into the hole of the lever correctly, and install the NEW servo with the three screws.

Figure 16.

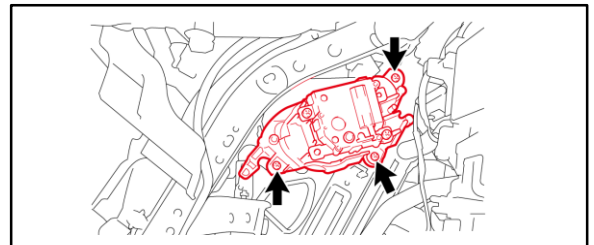

HVAC Servo Motor Malfunction

Damper Servo Sub-assembly Replacement Procedure (continued)

Replacement Procedure Group A (Servo Replacement on Vehicle) (continued)

9. Install the harness at the position shown and connect the connector.

CAUTION
 Make sure to route the harness as shown, otherwise the harness may run short and the connector may NOT connect.

Figure 17.

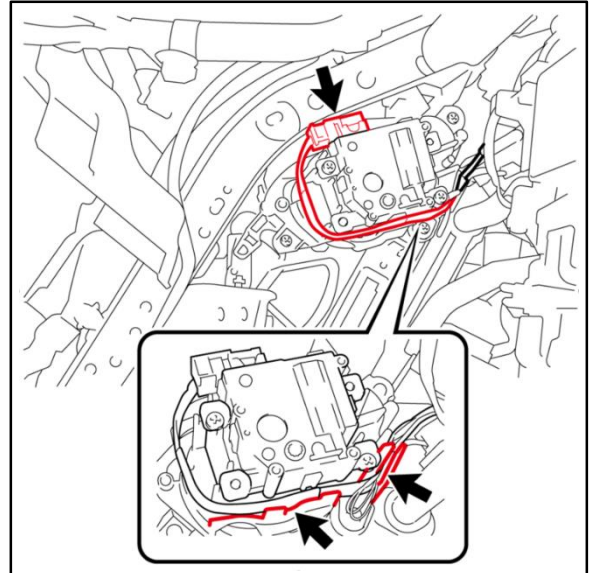

10. Connect the two connectors.

Figure 18.

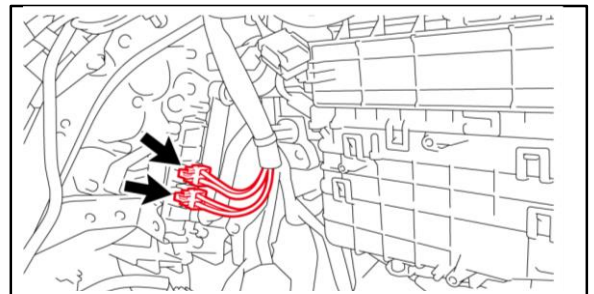

11. Reinstall the air conditioning amplifier and glove compartment door assembly.

Refer to TIS, applicable model and model year Repair Manual:

Vehicle Interior – Heating/Air Conditioning – “Heating / Air Conditioning: Air Conditioning Amplifier: Installation”

- GS200T: [2016](#) / [2017](#)
- GS350: [2013](#) / [2014](#) / [2015](#) / [2016](#) / [2017](#)
- GS450H: [2013](#) / [2014](#) / [2015](#) / [2016](#) / [2017](#)
- GS F: [2016](#) / [2017](#)

12. Is this the last servo being replaced?

- **YES** — [Continue to the Completion Procedure.](#)
- **NO** — [Go to the next servo replacement procedure.](#)

HVAC Servo Motor Malfunction

Damper Servo Sub-assembly Replacement Procedure (continued)

Replacement Procedure Group B (Servo Replacement on Vehicle)

- [1] Air Mix Servo (D) – DTC B1446 (IS, RC, and GS)
- [6] Cool A/M Servo (D) – DTC B1453 (IS, RC, and GS)
- [8] A/O Servo (Rr D) – DTC B1449 (GS ONLY)

NOTE

If servos from BOTH Group B and C require replacement, perform the air conditioning unit removal steps from Group C (pg. 47; step 1A.) first. Then, follow the corresponding servo motor replacement steps from Group B to replace the Group B servo(s). Replace ALL Group B and C servos BEFORE reinstalling the air conditioning unit.

Requires removal of:

- **Knee Airbag Assembly**
- **No. 1 Air Duct Sub-Assembly**

1. Remove the [1] air mix servo (D) – DTC B1446 (IS, RC, and GS).

A. Remove the knee airbag assembly (driver side).

Refer to TIS, applicable model and model year Repair Manual:

Vehicle Interior –
Supplemental Restraint Systems –
 “Supplemental Restraint Systems:
 Knee Airbag Assembly
 (for Driver Side): Removal”

- IS200T: [2016](#) / [2017](#)
- IS250: [2014](#) / [2015](#)
- IS300: [2016](#) / [2017](#)
- IS350: [2014](#) / [2015](#) / [2016](#) / [2017](#)
- RC200T: [2016](#) / [2017](#)
- RC300: [2016](#) / [2017](#)
- RC350: [2015](#) / [2016](#) / [2017](#)
- RC F: [2015](#) / [2016](#) / [2017](#)
- GS200T: [2016](#) / [2017](#)
- GS350: [2013](#) / [2014](#) / [2015](#) / [2016](#) / [2017](#)
- GS450H: [2013](#) / [2014](#) / [2015](#) / [2016](#) / [2017](#)
- GS F: [2016](#) / [2017](#)

Figure 19.

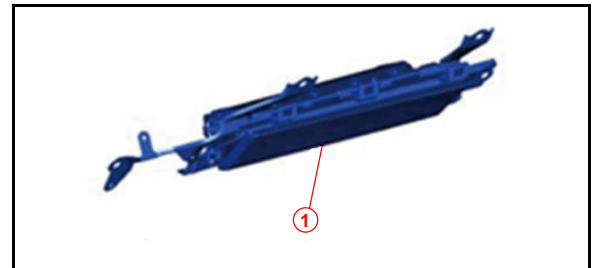

1	Knee Airbag Assembly (Driver Side)
----------	---

HVAC Servo Motor Malfunction

Damper Servo Sub-assembly Replacement Procedure (continued)

Replacement Procedure Group B (Servo Replacement on Vehicle) (continued)

B. Remove the No. 1 air duct sub-assembly.

Refer to TIS, applicable model and model year Repair Manual:

Steering – Steering Column – “Steering Column: Steering Column Assembly: Removal”

- IS200T: [2016](#) / [2017](#)
- IS250: [2014](#) / [2015](#)
- IS300: [2016](#) / [2017](#)
- IS350: [2014](#) / [2015](#) / [2016](#) / [2017](#)
- RC200T: [2016](#) / [2017](#)
- RC300: [2016](#) / [2017](#)
- RC350: [2015](#) / [2016](#) / [2017](#)
- RC F: [2015](#) / [2016](#) / [2017](#)

Vehicle Interior – Heating/Air Conditioning – “Heating / Air Conditioning: Air Conditioning Unit: Removal”

- GS200T: [2016](#) / [2017](#)
- GS350: [2013](#) / [2014](#) / [2015](#) / [2016](#) / [2017](#)
- GS450H: [2013](#) / [2014](#) / [2015](#) / [2016](#) / [2017](#)
- GS F: [2016](#) / [2017](#)

C. Disconnect the connector and remove the two screws and the servo.

NOTE

Reuse the attaching screws. If a screw is missing, order part number 90099-00968.

Figure 20. Air Mix Servo (D)

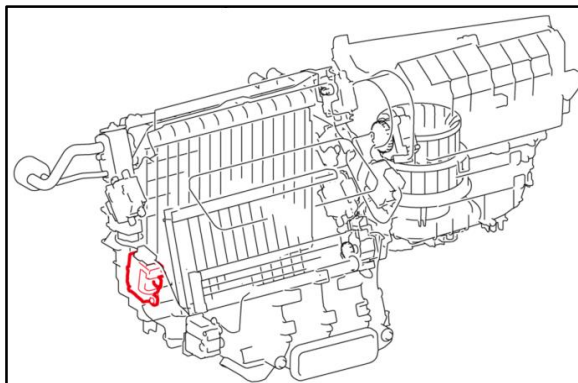
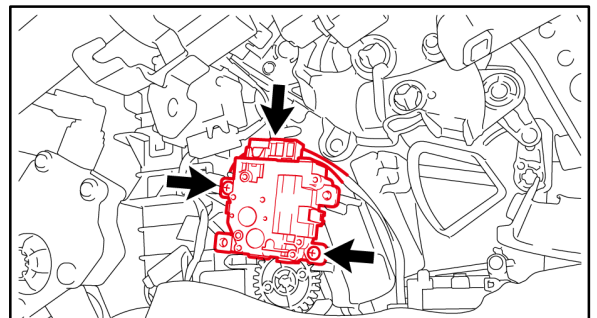

Figure 21.



HVAC Servo Motor Malfunction

Damper Servo Sub-assembly Replacement Procedure (continued)

Replacement Procedure Group B (Servo Replacement on Vehicle) (continued)

D. Mark and store the removed servo in a separate container to avoid reinstalling it in error.

E. Install the NEW air mix servo (D) by aligning the tooth-missed part of the gear with the corresponding mark on the case.

NOTE

The mark on the air conditioning unit side can be found on the housing surface above the gear.

Figure 22.

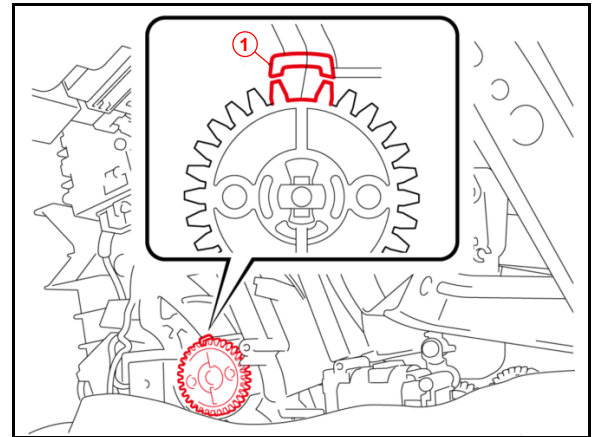

1	Mark
----------	-------------

F. Set the positions of the gear and the NEW servo and temporarily install the servo.

G. Install the NEW servo with the two screws and connect the connector.

Figure 23.

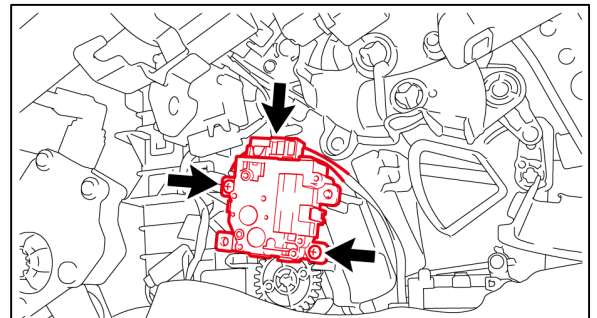

HVAC Servo Motor Malfunction

Damper Servo Sub-assembly Replacement Procedure (continued)

Replacement Procedure Group B (Servo Replacement on Vehicle) (continued)

H. Reinstall the No. 1 air duct sub-assembly.

Refer to TIS, applicable model and model year Repair Manual:

Steering – Steering Column – “Steering Column: Steering Column Assembly: Installation”

- IS200T: [2016](#) / [2017](#)
- IS250: [2014](#) / [2015](#)
- IS300: [2016](#) / [2017](#)
- IS350: [2014](#) / [2015](#) / [2016](#) / [2017](#)
- RC200T: [2016](#) / [2017](#)
- RC300: [2016](#) / [2017](#)
- RC350: [2015](#) / [2016](#) / [2017](#)
- RC F: [2015](#) / [2016](#) / [2017](#)

Vehicle Interior – Heating/Air Conditioning – “Heating / Air Conditioning:
Air Conditioning Unit: Installation”

- GS200T: [2016](#) / [2017](#)
- GS350: [2013](#) / [2014](#) / [2015](#) / [2016](#) / [2017](#)
- GS450H: [2013](#) / [2014](#) / [2015](#) / [2016](#) / [2017](#)
- GS F: [2016](#) / [2017](#)

HVAC Servo Motor Malfunction

Damper Servo Sub-assembly Replacement Procedure (continued)

Replacement Procedure Group B (Servo Replacement on Vehicle) (continued)

- I. Reinstall the knee airbag assembly (driver side).
Refer to TIS, applicable model and model year Repair Manual:
Vehicle Interior – Supplemental Restraint Systems – “Supplemental Restraint Systems: Knee Airbag Assembly (for Driver Side): Installation”
 - IS200T: [2016](#) / [2017](#)
 - IS250: [2014](#) / [2015](#)
 - IS300: [2016](#) / [2017](#)
 - IS350: [2014](#) / [2015](#) / [2016](#) / [2017](#)
 - RC200T: [2016](#) / [2017](#)
 - RC300: [2016](#) / [2017](#)
 - RC350: [2015](#) / [2016](#) / [2017](#)
 - RC F: [2015](#) / [2016](#) / [2017](#)
 - GS200T: [2016](#) / [2017](#)
 - GS350: [2013](#) / [2014](#) / [2015](#) / [2016](#) / [2017](#)
 - GS450H: [2013](#) / [2014](#) / [2015](#) / [2016](#) / [2017](#)
 - GS F: [2016](#) / [2017](#)

- J. Is this the last servo being replaced?
 - **YES** — [Continue to the Completion Procedure.](#)
 - **NO** — [Go to the next servo replacement procedure.](#)

HVAC Servo Motor Malfunction

Damper Servo Sub-assembly Replacement Procedure (continued)

Replacement Procedure Group B (Servo Replacement on Vehicle) (continued)

2. Remove the [6] cool air mix servo (D) – DTC B1453 (IS, RC, and GS).

A. Remove the knee airbag assembly (driver side).

Refer to TIS, applicable model and model year Repair Manual:

Vehicle Interior –

Supplemental Restraint Systems –

“Supplemental Restraint Systems:

Knee Airbag Assembly

(for Driver Side): Removal”

- IS200T: [2016](#) / [2017](#)
- IS250: [2014](#) / [2015](#)
- IS300: [2016](#) / [2017](#)
- IS350: [2014](#) / [2015](#) / [2016](#) / [2017](#)
- RC200T: [2016](#) / [2017](#)
- RC300: [2016](#) / [2017](#)
- RC350: [2015](#) / [2016](#) / [2017](#)
- RC F: [2015](#) / [2016](#) / [2017](#)
- GS200T: [2016](#) / [2017](#)
- GS350: [2013](#) / [2014](#) / [2015](#) / [2016](#) / [2017](#)
- GS450H: [2013](#) / [2014](#) / [2015](#) / [2016](#) / [2017](#)
- GS F: [2016](#) / [2017](#)

Figure 24.

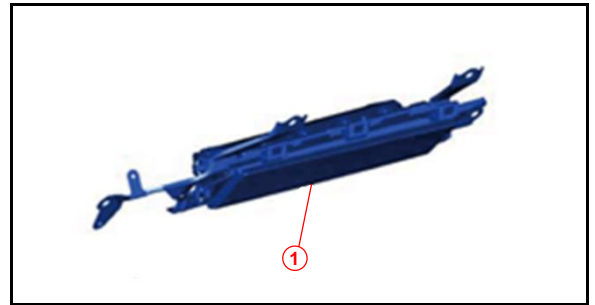

1	Knee Airbag Assembly (Driver Side)
----------	---

HVAC Servo Motor Malfunction

Damper Servo Sub-assembly Replacement Procedure (continued)

Replacement Procedure Group B (Servo Replacement on Vehicle) (continued)

B. Remove the No. 1 air duct sub-assembly.

Refer to TIS, applicable model and model year Repair Manual:

Steering – Steering Column – “Steering Column: Steering Column Assembly: Removal”

- IS200T: [2016](#) / [2017](#)
- IS250: [2014](#) / [2015](#)
- IS300: [2016](#) / [2017](#)
- IS350: [2014](#) / [2015](#) / [2016](#) / [2017](#)
- RC200T: [2016](#) / [2017](#)
- RC300: [2016](#) / [2017](#)
- RC350: [2015](#) / [2016](#) / [2017](#)
- RC F: [2015](#) / [2016](#) / [2017](#)

Vehicle Interior – Heating/Air Conditioning – “Heating / Air Conditioning:
Air Conditioning Unit: Removal”

- GS200T: [2016](#) / [2017](#)
- GS350: [2013](#) / [2014](#) / [2015](#) / [2016](#) / [2017](#)
- GS450H: [2013](#) / [2014](#) / [2015](#) / [2016](#) / [2017](#)
- GS F: [2016](#) / [2017](#)

C. Remove the driving support ECU assembly (w/dynamic radar cruise control system)
(for IS, RC, and RC F ONLY).

Refer to TIS, applicable model and model year Repair Manual:

Engine / Hybrid System – Cruise Control – “Cruise Control:
Driving Support ECU – Removal”

- IS200T: [2016](#) / [2017](#)
- IS250: [2014](#) / [2015](#)
- IS300: [2016](#) / [2017](#)
- IS350: [2014](#) / [2015](#) / [2016](#) / [2017](#)
- RC200T: [2016](#) / [2017](#)
- RC300: [2016](#) / [2017](#)
- RC350: [2015](#) / [2016](#) / [2017](#)
- RC F: [2015](#) / [2016](#) / [2017](#)

HVAC Servo Motor Malfunction

Damper Servo Sub-assembly Replacement Procedure (continued)

Replacement Procedure Group B (Servo Replacement on Vehicle) (continued)

D. Disconnect the two connectors.

Figure 25.

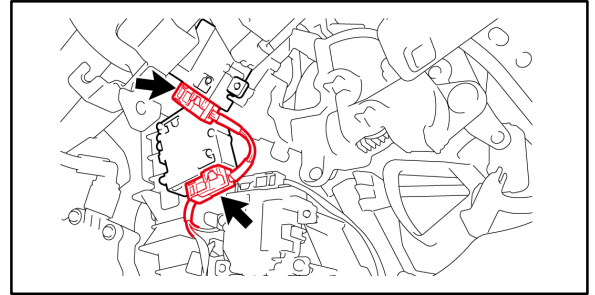

E. Remove the two screws and the servo.

NOTE

Reuse the attaching screws.
If a screw is missing, order part number 90099-00968.

Figure 26.

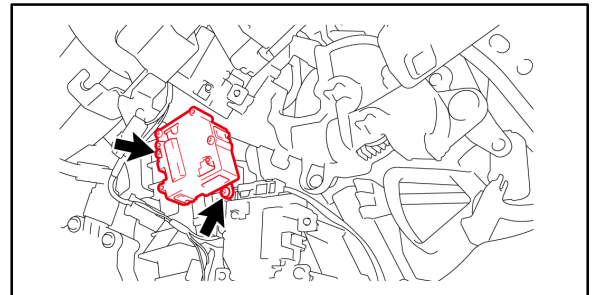

F. Mark and store the removed servo in a separate container to avoid reinstalling it in error.

G. Install the NEW [6] cool A/M servo (D) by turning the shaft with your hand so that the flat part of the shaft and the mark are aligned in parallel.

Figure 27.

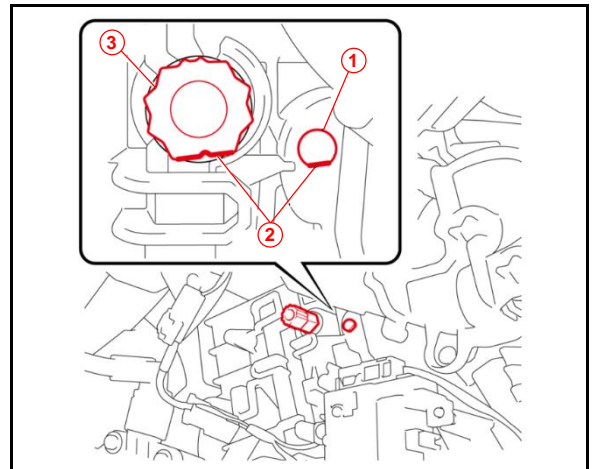

NOTE

The mark on the air conditioning unit side can be found on the housing surface next to the shaft.

1	Mark
2	Flat Part
3	Shaft

HVAC Servo Motor Malfunction

Damper Servo Sub-assembly Replacement Procedure (continued)

Replacement Procedure Group B (Servo Replacement on Vehicle) (continued)

- H. Set the positions of the shaft and the NEW servo to temporarily install the servo.

- I. Install the NEW servo with the two screws.

Figure 28.

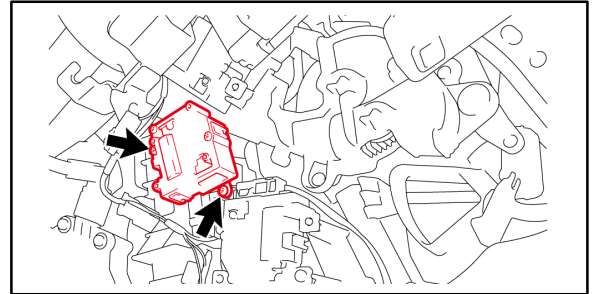

- J. Reconnect the two connectors.

Figure 29.

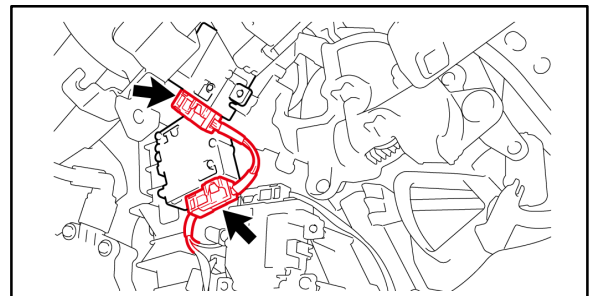

- K. Reinstall the driver support ECU assembly (w/dynamic radar cruise control system) (for IS, RC, and RC F ONLY).

Refer to TIS, applicable model and model year Repair Manual:

Engine / Hybrid System – Cruise Control – “Cruise Control:

Driving Support ECU: Installation”

- IS200T: [2016](#) / [2017](#)
- IS250: [2014](#) / [2015](#)
- IS300: [2016](#) / [2017](#)
- IS350: [2014](#) / [2015](#) / [2016](#) / [2017](#)
- RC200T: [2016](#) / [2017](#)
- RC300: [2016](#) / [2017](#)
- RC350: [2015](#) / [2016](#) / [2017](#)
- RC F: [2015](#) / [2016](#) / [2017](#)

HVAC Servo Motor Malfunction

Damper Servo Sub-assembly Replacement Procedure (continued)

Replacement Procedure Group B (Servo Replacement on Vehicle) (continued)

L. Reinstall the No. 1 air duct sub-assembly.

Refer to TIS, applicable model and model year Repair Manual:

Steering – Steering Column – “Steering Column: Steering Column Assembly: Installation”

- IS200T: [2016](#) / [2017](#)
- IS250: [2014](#) / [2015](#)
- IS300: [2016](#) / [2017](#)
- IS350: [2014](#) / [2015](#) / [2016](#) / [2017](#)
- RC200T: [2016](#) / [2017](#)
- RC300: [2016](#) / [2017](#)
- RC350: [2015](#) / [2016](#) / [2017](#)
- RC F: [2015](#) / [2016](#) / [2017](#)

Vehicle Interior – Heating/Air Conditioning – “Heating / Air Conditioning: Air Conditioning Unit: Installation”

- GS200T: [2016](#) / [2017](#)
- GS350: [2013](#) / [2014](#) / [2015](#) / [2016](#) / [2017](#)
- GS450H: [2013](#) / [2014](#) / [2015](#) / [2016](#) / [2017](#)
- GS F: [2016](#) / [2017](#)

M. Reinstall the knee airbag assembly (driver side).

Refer to TIS, applicable model and model year Repair Manual:

Vehicle Interior – Supplemental Restraint Systems – “Supplemental Restraint Systems: Knee Airbag Assembly (for Driver Side): Installation”

- IS200T: [2016](#) / [2017](#)
- IS250: [2014](#) / [2015](#)
- IS300: [2016](#) / [2017](#)
- IS350: [2014](#) / [2015](#) / [2016](#) / [2017](#)
- RC200T: [2016](#) / [2017](#)
- RC300: [2016](#) / [2017](#)
- RC350: [2015](#) / [2016](#) / [2017](#)
- RC F: [2015](#) / [2016](#) / [2017](#)
- GS200T: [2016](#) / [2017](#)
- GS350: [2013](#) / [2014](#) / [2015](#) / [2016](#) / [2017](#)
- GS450H: [2013](#) / [2014](#) / [2015](#) / [2016](#) / [2017](#)
- GS F: [2016](#) / [2017](#)

N. Is this the last servo being replaced?

- **YES** — [Continue to the Completion Procedure.](#)
- **NO** — [Go to the next servo replacement procedure.](#)

HVAC Servo Motor Malfunction

Damper Servo Sub-assembly Replacement Procedure (continued)

Replacement Procedure Group B (Servo Replacement on Vehicle) (continued)

3. Remove the [8] A/O servo (Rr D) – DTC B1449 (GS ONLY).

A. Remove the knee airbag assembly (driver side).

Refer to TIS, applicable model and model year Repair Manual:

Vehicle Interior – Supplemental Restraint Systems – “Supplemental Restraint Systems: Knee Airbag Assembly (for Driver Side): Removal”

- GS200T: [2016](#) / [2017](#)
- GS350: [2013](#) / [2014](#) / [2015](#) / [2016](#) / [2017](#)
- GS450H: [2013](#) / [2014](#) / [2015](#) / [2016](#) / [2017](#)
- GS F: [2016](#) / [2017](#)

Figure 30.

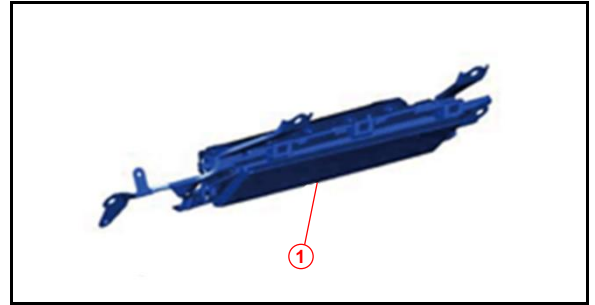

1	Knee Airbag Assembly (Driver Side)
----------	---

B. Remove the No. 1 air duct sub-assembly.

Refer to TIS, applicable model and model year Repair Manual:

Vehicle Interior – Heating/Air Conditioning – “Heating / Air Conditioning: Air Conditioning Unit: Removal”

- GS200T: [2016](#) / [2017](#)
- GS350: [2013](#) / [2014](#) / [2015](#) / [2016](#) / [2017](#)
- GS450H: [2013](#) / [2014](#) / [2015](#) / [2016](#) / [2017](#)
- GS F: [2016](#) / [2017](#)

HVAC Servo Motor Malfunction

Damper Servo Sub-assembly Replacement Procedure (continued)

Replacement Procedure Group B (Servo Replacement on Vehicle) (continued)

- C. Remove the instrument panel finish panel end LH, then remove the front No. 1 console box insert.

NOTE

The removal procedure for the instrument panel finish panel end LH is included in the Repair Manual procedure for front console box removal.

Refer to TIS, applicable model and model year Repair Manual:
Vehicle Interior – Interior Panels/Trim – “Interior Panels / Trim: Front Console Box: Removal”

- GS200T: [2016](#) / [2017](#)
- GS350: [2013](#) / [2014](#) / [2015](#) / [2016](#) / [2017](#)
- GS450H: [2013](#) / [2014](#) / [2015](#) / [2016](#) / [2017](#)
- GS F: [2016](#) / [2017](#)

- D. Remove the carpet clip and fold back the carpet enough so that the servo can be removed.

Figure 31.

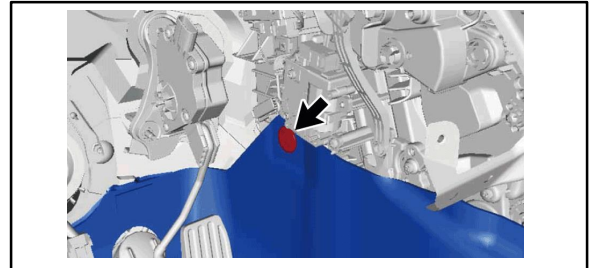

- E. Disconnect the connector from the servo.

Figure 32.

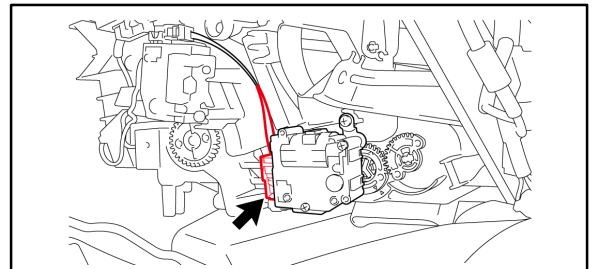

- F. Remove the two screws.

NOTE

Reuse the attaching screws.
 If a screw is missing, order part number 90099-00968.

Figure 33.

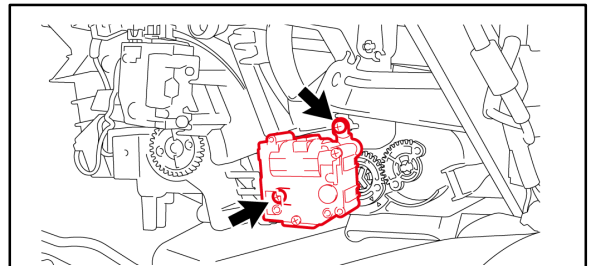

HVAC Servo Motor Malfunction

Damper Servo Sub-assembly Replacement Procedure (continued)

Replacement Procedure Group B (Servo Replacement on Vehicle) (continued)

- G. Insert a screwdriver wrapped in protective tape between the gap of the servo and gear and remove the servo.

NOTE

The gear remains on the air conditioning unit side.

Figure 34.

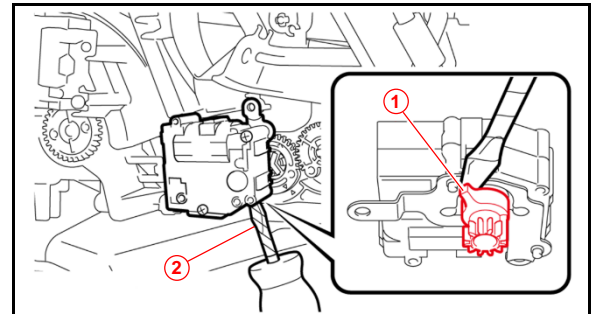

1	Insertion Point
2	Protective Tape

- H. Turn the gear with your hand until it can be removed, then remove the gear.

Figure 35.

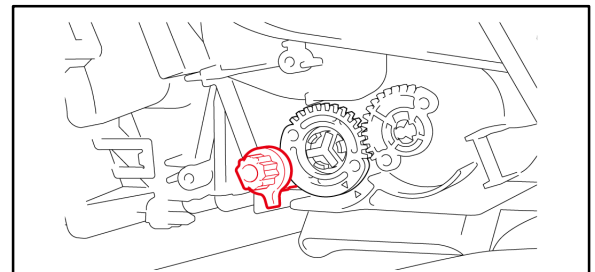

- I. Mark and store the removed servo in a separate container to avoid reinstalling it in error.

- J. Install the NEW [8] A/O Servo (Rr D) by turning the gear by hand and placing it as shown.

NOTE

The mark on the air conditioning unit side is found at the inner part of the housing surface.

Figure 36.

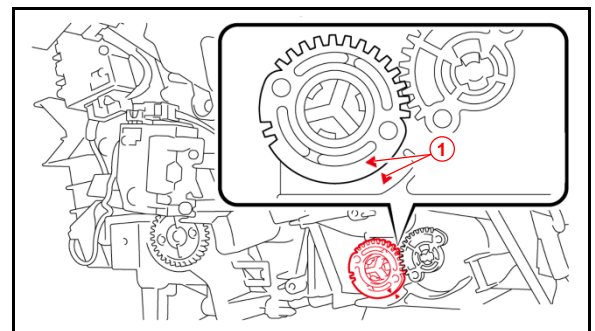

1	Match Mark
----------	-------------------

HVAC Servo Motor Malfunction

Damper Servo Sub-assembly Replacement Procedure (continued)

Replacement Procedure Group B (Servo Replacement on Vehicle) (continued)

- K. Align the long teeth of the servo gear with the teeth of the gear and temporarily install the NEW servo.

Figure 37.

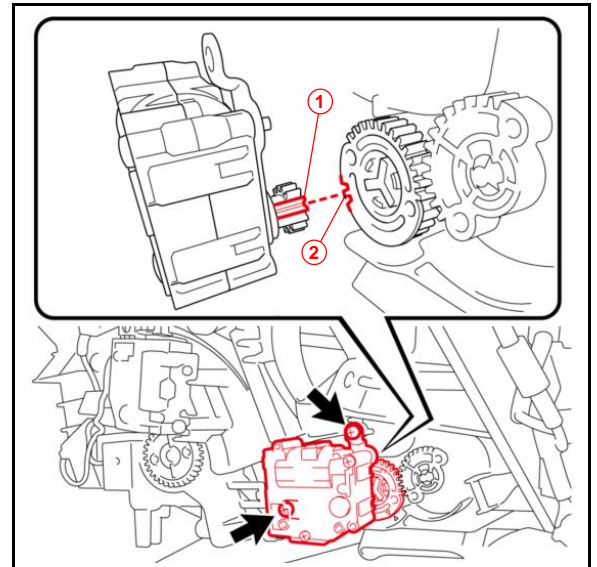

1	Long Teeth
2	Alignment Point

- L. Reconnect the connector.

Figure 38.

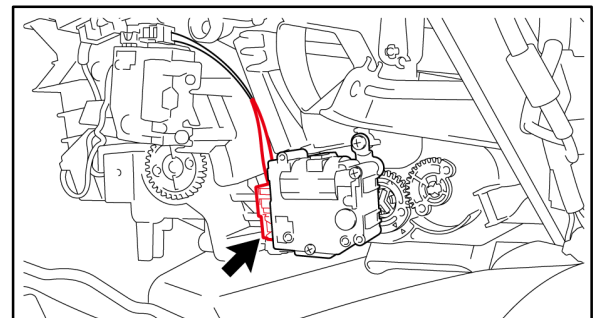

HVAC Servo Motor Malfunction

Damper Servo Sub-assembly Replacement Procedure (continued)

Replacement Procedure Group B (Servo Replacement on Vehicle) (continued)

- M. Restore the carpet and reinstall the clip.

Figure 39.

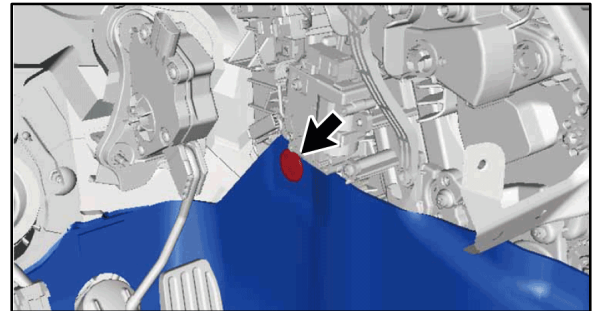

- N. Reinstall the front No. 1 console box insert, then reinstall the instrument panel finish panel end LH.

NOTE

The installation procedure for the instrument panel finish panel end LH is included in the Repair Manual procedure for front console box installation.

Refer to TIS, applicable model and model year Repair Manual:
Vehicle Interior – Interior Panels/Trim – “Interior Panels / Trim:
 Front Console Box: Installation”

- GS200T: [2016](#) / [2017](#)
- GS350: [2013](#) / [2014](#) / [2015](#) / [2016](#) / [2017](#)
- GS450H: [2013](#) / [2014](#) / [2015](#) / [2016](#) / [2017](#)
- GS F: [2016](#) / [2017](#)

- O. Reinstall the No. 1 air duct assembly.

Refer to TIS, applicable model and model year Repair Manual:
Vehicle Interior – Heating/Air Conditioning – “Heating / Air Conditioning:
 Air Conditioning Unit: Installation”

- GS200T: [2016](#) / [2017](#)
- GS350: [2013](#) / [2014](#) / [2015](#) / [2016](#) / [2017](#)
- GS450H: [2013](#) / [2014](#) / [2015](#) / [2016](#) / [2017](#)
- GS F: [2016](#) / [2017](#)

HVAC Servo Motor Malfunction

Damper Servo Sub-assembly Replacement Procedure (continued)

Replacement Procedure Group B (Servo Replacement on Vehicle) (continued)

- P. Reinstall the knee airbag assembly (driver side).
Refer to TIS, applicable model and model year Repair Manual:
Vehicle Interior – Supplemental Restraint Systems – “Supplemental Restraint Systems:
Knee Airbag Assembly(for Driver Side): Installation”
- GS200T: [2016](#) / [2017](#)
 - GS350: [2013](#) / [2014](#) / [2015](#) / [2016](#) / [2017](#)
 - GS450H: [2013](#) / [2014](#) / [2015](#) / [2016](#) / [2017](#)
 - GS F: [2016](#) / [2017](#)
- Q. Is this the last servo being replaced?
- **YES** — [Continue to the Completion Procedure.](#)
 - **NO** — [Go to the next servo replacement procedure.](#)

HVAC Servo Motor Malfunction

Damper Servo Sub-assembly Replacement Procedure (continued)

Replacement Procedure Group C (Servos Replaced From A/C Unit Removed From Vehicle)

- [2] Air Mix Servo (P) – DTC B1441 (IS, RC, and GS)
- [3] Air Outlet Servo (D) – DTC B1443 (IS, RC, and GS)
- [5] Air Inlet Damper Servo – DTC B1442 (IS, RC, and GS)
- [7] Cool A/M Servo (P) – DTC B1454 (IS, RC, and GS)
- [9] Rear Air Mix Servo – DTC B1447 (GS ONLY)
- [10] DEF A/O Servo (D) – DTC B1455 (IS, RC, and GS)

1. Remove the [2] air mix servo (P) – DTC B1441 (IS, RC, and GS) and [9] rear air mix servo – DTC B1447 (GS ONLY).

NOTE

The replacement procedure for [2] air mix servo (P) and [9] rear air mix servo are combined (replaced as a set) as both servos are mounted together on one module.

- A. Remove the air conditioning unit and blower assembly from the vehicle together as an assembly.

Refer to TIS, applicable model and model year Repair Manual:

Vehicle Interior –

Heating/Air Conditioning –

“Heating / Air Conditioning: Air Conditioning Unit: Removal”

Figure 40.

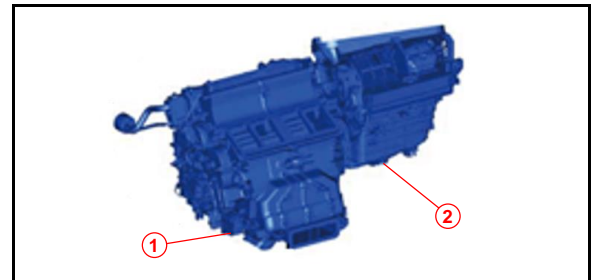

1	Air Conditioning Unit
2	Blower Assembly

- IS200T: [2016](#) / [2017](#)
- IS250: [2014](#) / [2015](#)
- IS300: [2016](#) / [2017](#)
- IS350: [2014](#) / [2015](#) / [2016](#) / [2017](#)
- RC200T: [2016](#) / [2017](#)
- RC300: [2016](#) / [2017](#)
- RC350: [2015](#) / [2016](#) / [2017](#)
- RC F: [2015](#) / [2016](#) / [2017](#)
- GS200T: [2016](#) / [2017](#)
- GS350: [2013](#) / [2014](#) / [2015](#) / [2016](#) / [2017](#)
- GS450H: [2013](#) / [2014](#) / [2015](#) / [2016](#) / [2017](#)
- GS F: [2016](#) / [2017](#)

HVAC Servo Motor Malfunction

Damper Servo Sub-assembly Replacement Procedure (continued)

Replacement Procedure Group C (Servos Replaced From A/C Unit Removed From Vehicle) (continued)

B. Separate the blower assembly from the air conditioning unit.

Refer to TIS, applicable model and model year Repair Manual:

Vehicle Interior – Heating/Air Conditioning – “Heating / Air Conditioning: Blower Unit: Removal”

- IS200T: [2016](#) / [2017](#)
- IS250: [2014](#) / [2015](#)
- IS300: [2016](#) / [2017](#)
- IS350: [2014](#) / [2015](#) / [2016](#) / [2017](#)
- RC200T: [2016](#) / [2017](#)
- RC300: [2016](#) / [2017](#)
- RC350: [2015](#) / [2016](#) / [2017](#)
- RC F: [2015](#) / [2016](#) / [2017](#)
- GS200T: [2016](#) / [2017](#)
- GS350: [2013](#) / [2014](#) / [2015](#) / [2016](#) / [2017](#)
- GS450H: [2013](#) / [2014](#) / [2015](#) / [2016](#) / [2017](#)
- GS F: [2016](#) / [2017](#)

C. Disconnect each connector.

NOTE

The number of connectors to disconnect depends on the vehicle specification.

Figure 41.

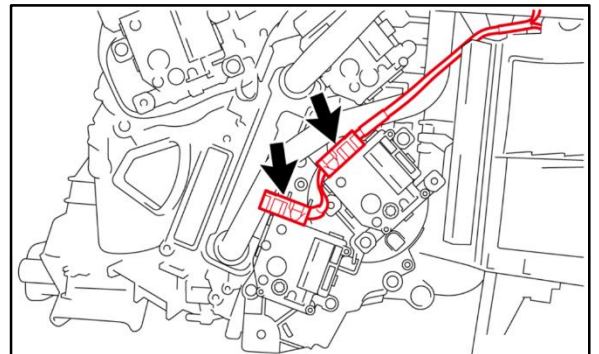

D. Disengage the claws and remove the clamp.

Figure 42.

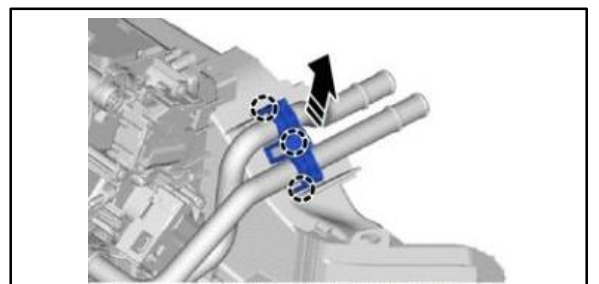

HVAC Servo Motor Malfunction

Damper Servo Sub-assembly Replacement Procedure (continued)

Replacement Procedure Group C (Servos Replaced From A/C Unit Removed From Vehicle) (continued)

- E. Remove the heater radiator unit sub-assembly.

NOTE

Prepare a drain pan or cloth in case the coolant leaks out.

Figure 43.

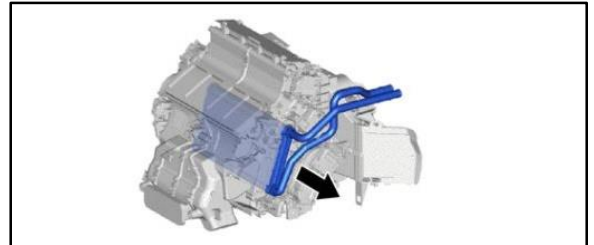

- F. Remove the three screws and the [2] air mix servo (P) and [9] rear air mix servo module.

NOTE

- Do NOT remove the screws on the servo body.
- Be careful not to hit and damage the housing when removing the servo.
- Reuse the screws. If a screw is missing, order part number 90099-00968)

Figure 44.

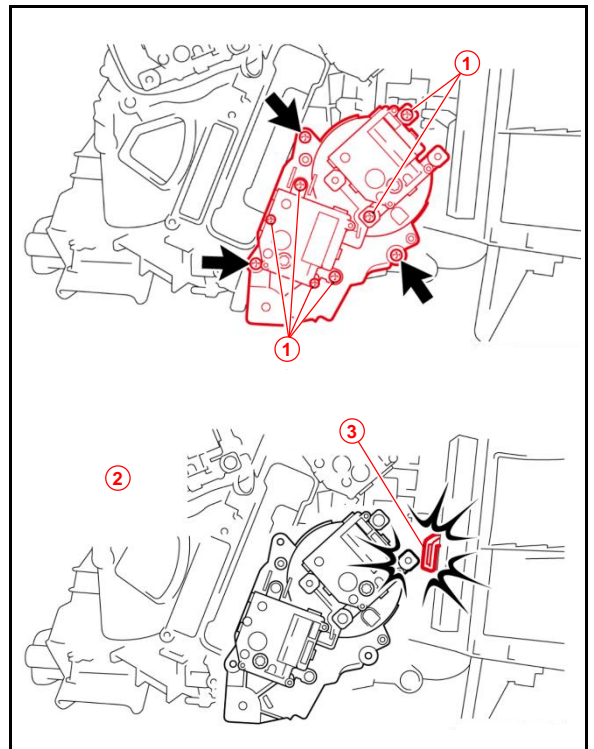

1	Do Not Remove
2	NG
3	Do Not Hit

- G. Mark and store the removed servo in a separate container to avoid reinstalling it in error.

HVAC Servo Motor Malfunction

Damper Servo Sub-assembly Replacement Procedure (continued)

Replacement Procedure Group C (Servos Replaced From A/C Unit Removed From Vehicle) (continued)

- H. Install the NEW [2] air mix servo (P) and NEW [9] rear air mix servo by turning both outer and inner shafts by hand to align the angles with the marks.

NOTE

- The mark on the air conditioning unit side can be found on the housing surface next to the shaft.
- Both shafts **MUST** be aligned to install the servo.

Figure 45.

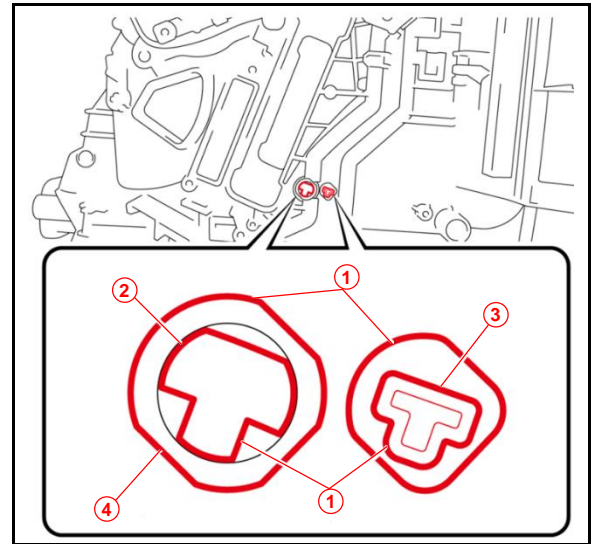

1	Align
2	Inner Shaft
3	Mark
4	Outer Shaft

- I. Set the positions of the shaft and servo to temporarily install the NEW servo.

HVAC Servo Motor Malfunction

Damper Servo Sub-assembly Replacement Procedure (continued)

Replacement Procedure Group C (Servos Replaced From A/C Unit Removed From Vehicle) (continued)

- J. Install the NEW servo with the three screws and reinstall each connector.

Figure 46.

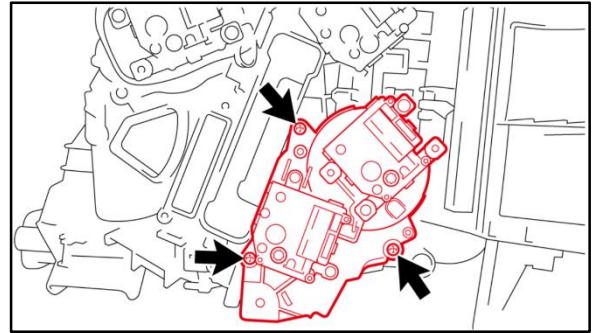
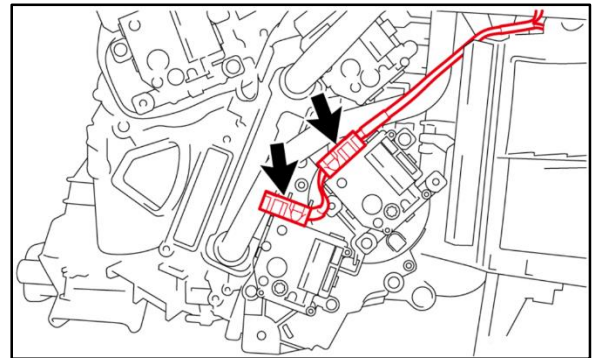

Figure 47.



- K. Reinstall the blower assembly to the air conditioning unit.

Refer to TIS, applicable model and model year Repair Manual:

Vehicle Interior – Heating/Air Conditioning – “Heating / Air Conditioning:
Blower Unit: Installation”

- IS200T: [2016](#) / [2017](#)
- IS250: [2014](#) / [2015](#)
- IS300: [2016](#) / [2017](#)
- IS350: [2014](#) / [2015](#) / [2016](#) / [2017](#)
- RC200T: [2016](#) / [2017](#)
- RC300: [2016](#) / [2017](#)
- RC350: [2015](#) / [2016](#) / [2017](#)
- RC F: [2015](#) / [2016](#) / [2017](#)
- GS200T: [2016](#) / [2017](#)
- GS350: [2013](#) / [2014](#) / [2015](#) / [2016](#) / [2017](#)
- GS450H: [2013](#) / [2014](#) / [2015](#) / [2016](#) / [2017](#)
- GS F: [2016](#) / [2017](#)

HVAC Servo Motor Malfunction

Damper Servo Sub-assembly Replacement Procedure (continued)

Replacement Procedure Group C (Servos Replaced From A/C Unit Removed From Vehicle) (continued)

L. Reinstall the air conditioning unit.

Refer to TIS, applicable model and model year Repair Manual:

*Vehicle Interior – Heating/Air Conditioning – “Heating / Air Conditioning:
Air Conditioning Unit: Installation”*

- IS200T: [2016](#) / [2017](#)
- IS250: [2014](#) / [2015](#)
- IS300: [2016](#) / [2017](#)
- IS350: [2014](#) / [2015](#) / [2016](#) / [2017](#)
- RC200T: [2016](#) / [2017](#)
- RC300: [2016](#) / [2017](#)
- RC350: [2015](#) / [2016](#) / [2017](#)
- RC F: [2015](#) / [2016](#) / [2017](#)
- GS200T: [2016](#) / [2017](#)
- GS350: [2013](#) / [2014](#) / [2015](#) / [2016](#) / [2017](#)
- GS450H: [2013](#) / [2014](#) / [2015](#) / [2016](#) / [2017](#)
- GS F: [2016](#) / [2017](#)

M. Is this the last servo being replaced?

- **YES** — [Continue to the Completion Procedure.](#)
- **NO** — [Go to the next servo replacement procedure.](#)

HVAC Servo Motor Malfunction

Damper Servo Sub-assembly Replacement Procedure (continued)

Replacement Procedure Group C (Servos Replaced From A/C Unit Removed From Vehicle) (continued)

2. Remove the [7] Cool A/M Servo (P) – DTC B1454 (IS, RC, and GS).

A. Remove the air conditioning unit and blower assembly from the vehicle together as an assembly.

Refer to TIS, applicable model and model year Repair Manual:

Vehicle Interior –

Heating/Air Conditioning –

“Heating / Air Conditioning: Air Conditioning Unit: Removal”

- IS200T: [2016](#) / [2017](#)
- IS250: [2014](#) / [2015](#)
- IS300: [2016](#) / [2017](#)
- IS350: [2014](#) / [2015](#) / [2016](#) / [2017](#)
- RC200T: [2016](#) / [2017](#)
- RC300: [2016](#) / [2017](#)
- RC350: [2015](#) / [2016](#) / [2017](#)
- RC F: [2015](#) / [2016](#) / [2017](#)
- GS200T: [2016](#) / [2017](#)
- GS350: [2013](#) / [2014](#) / [2015](#) / [2016](#) / [2017](#)
- GS450H: [2013](#) / [2014](#) / [2015](#) / [2016](#) / [2017](#)
- GS F: [2016](#) / [2017](#)

Figure 48.

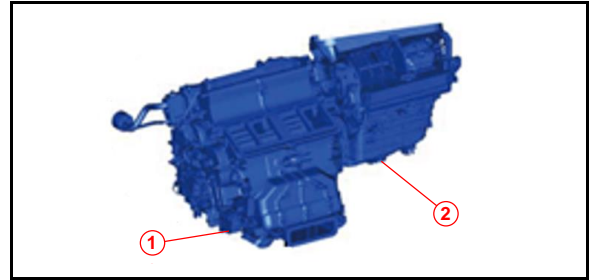

1	Air Conditioning Unit
2	Blower Assembly

HVAC Servo Motor Malfunction

Damper Servo Sub-assembly Replacement Procedure (continued)

Replacement Procedure Group C (Servos Replaced From A/C Unit Removed From Vehicle) (continued)

B. Separate the blower assembly from the air conditioning unit.

Refer to TIS, applicable model and model year Repair Manual:

Vehicle Interior – Heating/Air Conditioning – “Heating / Air Conditioning: Blower Unit: Removal”

- IS200T: [2016](#) / [2017](#)
- IS250: [2014](#) / [2015](#)
- IS300: [2016](#) / [2017](#)
- IS350: [2014](#) / [2015](#) / [2016](#) / [2017](#)
- RC200T: [2016](#) / [2017](#)
- RC300: [2016](#) / [2017](#)
- RC350: [2015](#) / [2016](#) / [2017](#)
- RC F: [2015](#) / [2016](#) / [2017](#)
- GS200T: [2016](#) / [2017](#)
- GS350: [2013](#) / [2014](#) / [2015](#) / [2016](#) / [2017](#)
- GS450H: [2013](#) / [2014](#) / [2015](#) / [2016](#) / [2017](#)
- GS F: [2016](#) / [2017](#)

C. Disconnect the connector.

Figure 49.

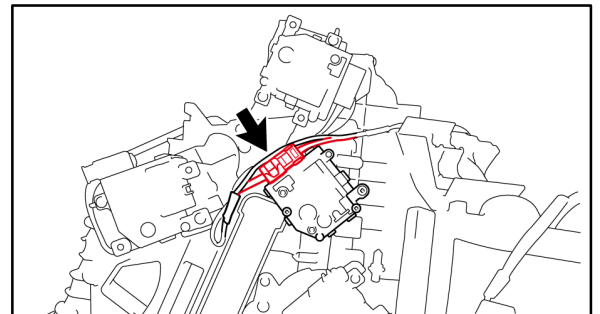

D. Remove the two screws and the servo.

NOTE

Reuse the screws. If a screw is missing, order part number 90099-00968.

Figure 50.

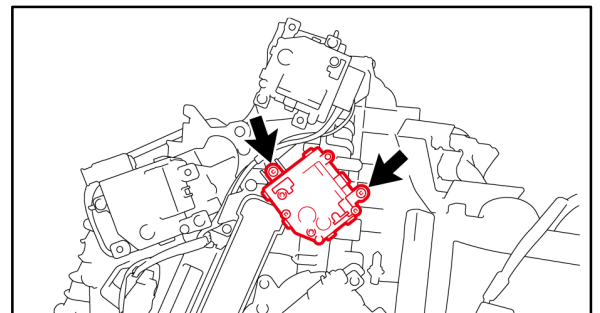

HVAC Servo Motor Malfunction

Damper Servo Sub-assembly Replacement Procedure (continued)

Replacement Procedure Group C (Servos Replaced From A/C Unit Removed From Vehicle) (continued)

E. Mark and store the removed servo in a separate container to avoid reinstalling it in error.

F. Install the NEW [7] cool A/M servo (P) by turning the shaft by hand so that the flat part of the shaft and the mark are aligned in parallel.

NOTE

The mark on the air conditioning unit side can be found on the housing surface above the shaft.

Figure 51.

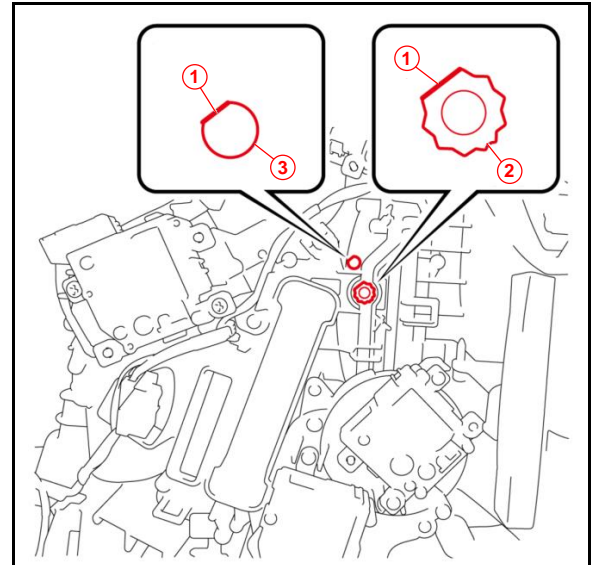

1	Flat Part
2	Shaft
3	Mark

G. Set the positions of the shaft and servo to temporarily install the NEW servo.

H. Install the NEW servo with the two screws.

Figure 52.

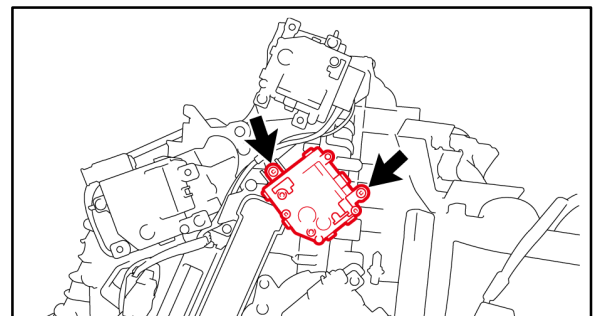

HVAC Servo Motor Malfunction

Damper Servo Sub-assembly Replacement Procedure (continued)

Replacement Procedure Group C (Servos Replaced From A/C Unit Removed From Vehicle) (continued)

- I. Reconnect the connector.

Figure 53.

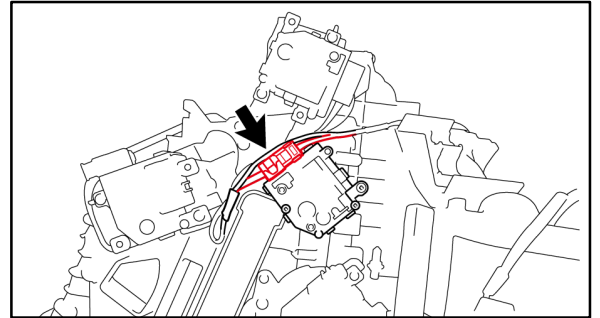

- J. Reinstall the heater radiator unit sub-assembly.

Figure 54.

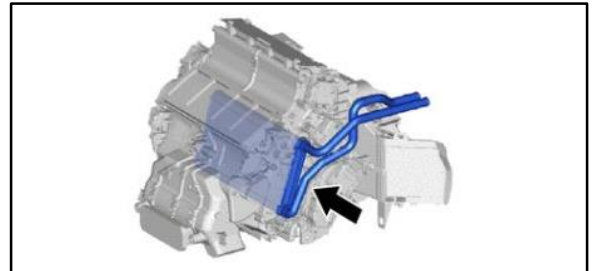

- K. Engage the claws to install the clamp.

Figure 55.

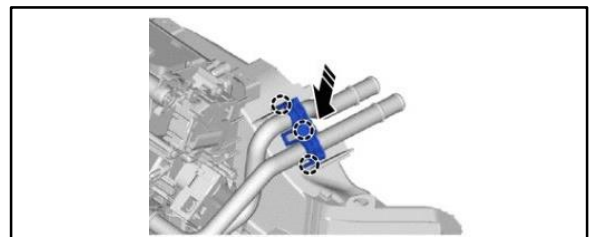

HVAC Servo Motor Malfunction

Damper Servo Sub-assembly Replacement Procedure (continued)

Replacement Procedure Group C (Servos Replaced From A/C Unit Removed From Vehicle) (continued)

- L. Reinstall the blower assembly to the air conditioning unit.

Refer to TIS, applicable model and model year Repair Manual:

Vehicle Interior – Heating/Air Conditioning – “Heating / Air Conditioning:
Blower Unit: Installation”

- IS200T: [2016](#) / [2017](#)
- IS250: [2014](#) / [2015](#)
- IS300: [2016](#) / [2017](#)
- IS350: [2014](#) / [2015](#) / [2016](#) / [2017](#)
- RC200T: [2016](#) / [2017](#)
- RC300: [2016](#) / [2017](#)
- RC350: [2015](#) / [2016](#) / [2017](#)
- RC F: [2015](#) / [2016](#) / [2017](#)
- GS200T: [2016](#) / [2017](#)
- GS350: [2013](#) / [2014](#) / [2015](#) / [2016](#) / [2017](#)
- GS450H: [2013](#) / [2014](#) / [2015](#) / [2016](#) / [2017](#)
- GS F: [2016](#) / [2017](#)

- M. Reinstall the air conditioning unit.

Refer to TIS, applicable model and model year Repair Manual:

Vehicle Interior – Heating/Air Conditioning – “Heating / Air Conditioning:
Air Conditioning Unit: Installation”

- IS200T: [2016](#) / [2017](#)
- IS250: [2014](#) / [2015](#)
- IS300: [2016](#) / [2017](#)
- IS350: [2014](#) / [2015](#) / [2016](#) / [2017](#)
- RC200T: [2016](#) / [2017](#)
- RC300: [2016](#) / [2017](#)
- RC350: [2015](#) / [2016](#) / [2017](#)
- RC F: [2015](#) / [2016](#) / [2017](#)
- GS200T: [2016](#) / [2017](#)
- GS350: [2013](#) / [2014](#) / [2015](#) / [2016](#) / [2017](#)
- GS450H: [2013](#) / [2014](#) / [2015](#) / [2016](#) / [2017](#)
- GS F: [2016](#) / [2017](#)

HVAC Servo Motor Malfunction

Damper Servo Sub-assembly Replacement Procedure (continued)

Replacement Procedure Group C (Servos Replaced From A/C Unit Removed From Vehicle) (continued)

- N. Is this the last servo being replaced?
- **YES** — [Continue to the Completion Procedure.](#)
 - **NO** — [Go to the next servo replacement procedure.](#)

3. Remove the [5] air inlet damper servo – DTC B1442 (IS, RC, and GS).

- A. Remove the air conditioning unit and blower assembly from the vehicle together as an assembly.

Refer to TIS, applicable model and model year Repair Manual:

*Vehicle Interior –
Heating/Air Conditioning –
“Heating / Air Conditioning: Air
Conditioning Unit: Removal”*

- IS200T: [2016](#) / [2017](#)
- IS250: [2014](#) / [2015](#)
- IS300: [2016](#) / [2017](#)
- IS350: [2014](#) / [2015](#) / [2016](#) / [2017](#)
- RC200T: [2016](#) / [2017](#)
- RC300: [2016](#) / [2017](#)
- RC350: [2015](#) / [2016](#) / [2017](#)
- RC F: [2015](#) / [2016](#) / [2017](#)
- GS200T: [2016](#) / [2017](#)
- GS350: [2013](#) / [2014](#) / [2015](#) / [2016](#) / [2017](#)
- GS450H: [2013](#) / [2014](#) / [2015](#) / [2016](#) / [2017](#)
- GS F: [2016](#) / [2017](#)

Figure 56.

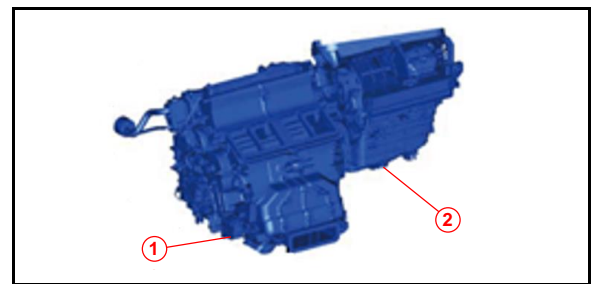

1	Air Conditioning Unit
2	Blower Assembly

HVAC Servo Motor Malfunction

Damper Servo Sub-assembly Replacement Procedure (continued)

Replacement Procedure Group C (Servos Replaced From A/C Unit Removed From Vehicle) (continued)

B. Remove the blower assembly from the air conditioning unit.

Refer to TIS, applicable model and model year Repair Manual:

Vehicle Interior – Heating/Air Conditioning – “Heating / Air Conditioning: Blower Unit: Removal”

- IS200T: [2016](#) / [2017](#)
- IS250: [2014](#) / [2015](#)
- IS300: [2016](#) / [2017](#)
- IS350: [2014](#) / [2015](#) / [2016](#) / [2017](#)
- RC200T: [2016](#) / [2017](#)
- RC300: [2016](#) / [2017](#)
- RC350: [2015](#) / [2016](#) / [2017](#)
- RC F: [2015](#) / [2016](#) / [2017](#)
- GS200T: [2016](#) / [2017](#)
- GS350: [2013](#) / [2014](#) / [2015](#) / [2016](#) / [2017](#)
- GS450H: [2013](#) / [2014](#) / [2015](#) / [2016](#) / [2017](#)
- GS F: [2016](#) / [2017](#)

C. Using a screwdriver wrapped in protective tape, remove the heater air damper control lever.

Figure 57.

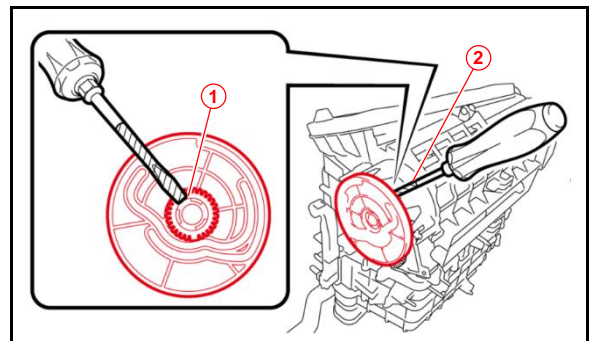

1	Contact Point
2	Protective Tape

HVAC Servo Motor Malfunction

Damper Servo Sub-assembly Replacement Procedure (continued)

Replacement Procedure Group C (Servos Replaced From A/C Unit Removed From Vehicle) (continued)

- D. Remove the two screws and servo and disconnect the connector.

NOTE

Reuse the screws. If a screw is missing, order part number 90099-00968.

Figure 58.

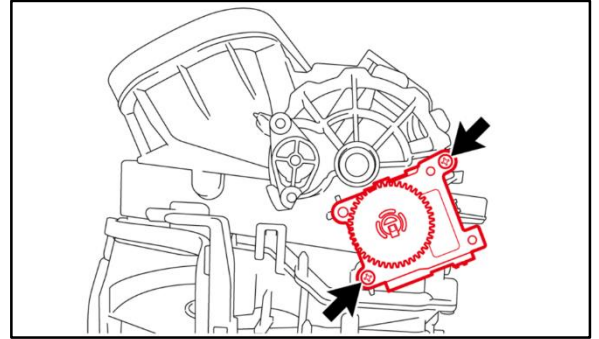

- E. Mark and store the removed servo and lever in a separate container to avoid reinstalling them in error.

- F. Install the NEW [5] air inlet damper servo by reinstalling the two screws.

Figure 59.

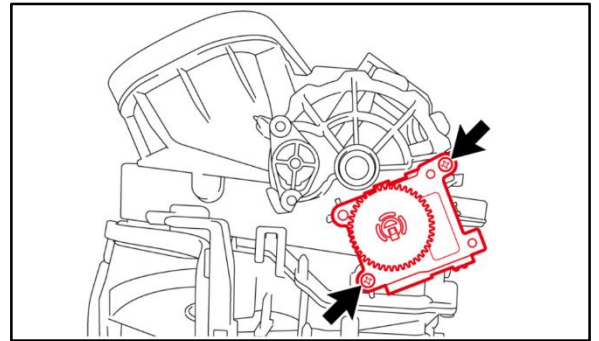

- G. Turn the two door levers by hand to set to the position shown.

Figure 60.

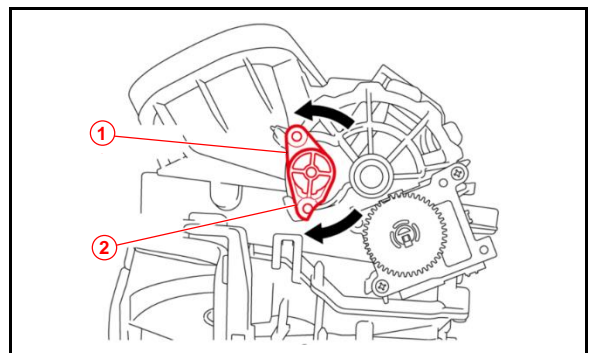

1	Door Lever 1
2	Door Lever 2

HVAC Servo Motor Malfunction

Damper Servo Sub-assembly Replacement Procedure (continued)

Replacement Procedure Group C (Servos Replaced From A/C Unit Removed From Vehicle) (continued)

- H. Look through the peephole of the heater air damper control lever to align the tooth-missed part of the gear, and temporarily install the heater air damper control lever.

- I. Confirm that the pins of the two door levers are inserted into the holes of the heater air damper control lever, then install the heater air damper control lever.

Figure 61.

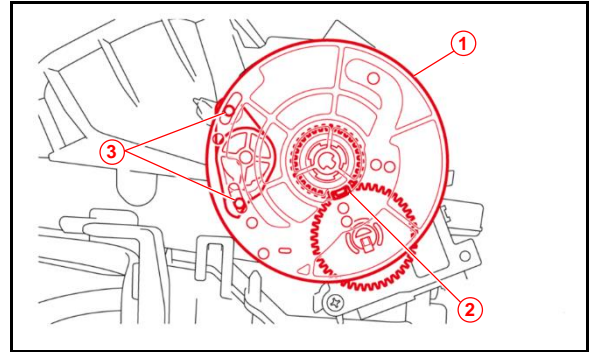

1	Heater Air Damper Control Lever
2	Peephole
3	Pin

- J. Reconnect the servo connector.

- K. Reinstall the blower assembly to the air conditioning unit.
 Refer to TIS, applicable model and model year Repair Manual:
Vehicle Interior – Heating/Air Conditioning – “Heating / Air Conditioning: Blower Unit: Installation”
 - IS200T: [2016](#) / [2017](#)
 - IS250: [2014](#) / [2015](#)
 - IS300: [2016](#) / [2017](#)
 - IS350: [2014](#) / [2015](#) / [2016](#) / [2017](#)
 - RC200T: [2016](#) / [2017](#)
 - RC300: [2016](#) / [2017](#)
 - RC350: [2015](#) / [2016](#) / [2017](#)
 - RC F: [2015](#) / [2016](#) / [2017](#)
 - GS200T: [2016](#) / [2017](#)
 - GS350: [2013](#) / [2014](#) / [2015](#) / [2016](#) / [2017](#)
 - GS450H: [2013](#) / [2014](#) / [2015](#) / [2016](#) / [2017](#)
 - GS F: [2016](#) / [2017](#)

HVAC Servo Motor Malfunction

Damper Servo Sub-assembly Replacement Procedure (continued)

Replacement Procedure Group C (Servos Replaced From A/C Unit Removed From Vehicle) (continued)

L. Reinstall the air conditioning unit.

Refer to TIS, applicable model and model year Repair Manual:

Vehicle Interior – Heating/Air Conditioning – “Heating / Air Conditioning: Air Conditioning Unit: Installation”

- IS200T: [2016](#) / [2017](#)
- IS250: [2014](#) / [2015](#)
- IS300: [2016](#) / [2017](#)
- IS350: [2014](#) / [2015](#) / [2016](#) / [2017](#)
- RC200T: [2016](#) / [2017](#)
- RC300: [2016](#) / [2017](#)
- RC350: [2015](#) / [2016](#) / [2017](#)
- RC F: [2015](#) / [2016](#) / [2017](#)
- GS200T: [2016](#) / [2017](#)
- GS350: [2013](#) / [2014](#) / [2015](#) / [2016](#) / [2017](#)
- GS450H: [2013](#) / [2014](#) / [2015](#) / [2016](#) / [2017](#)
- GS F: [2016](#) / [2017](#)

M. Is this the last servo being replaced?

- **YES** — [Continue to the Completion Procedure.](#)
- **NO** — [Go to the next servo replacement procedure.](#)

HVAC Servo Motor Malfunction

Damper Servo Sub-assembly Replacement Procedure (continued)

Replacement Procedure Group C (Servos Replaced From A/C Unit Removed From Vehicle) (continued)

4. Remove the [3] air outlet servo (D) – DTC B1443 (W/lever type) (IS and RC ONLY).

NOTE

There are two types of [3] air outlet servo (D):

- W/Lever Type (IS and RC) – Step 4.
- W/O Lever Type (GS) – Go to Step 5.

Figure 62. Air Outlet Servo (D)

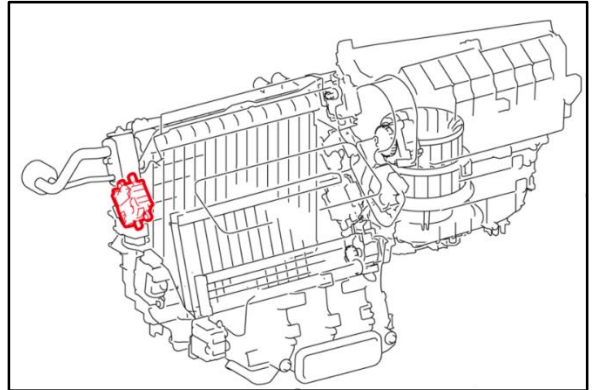

A. Remove the air conditioning unit and blower assembly from the vehicle together as an assembly.

Refer to TIS, applicable model and model year Repair Manual:

Vehicle Interior – Heating/Air Conditioning – “Heating / Air Conditioning: Air Conditioning Unit: Removal”

- IS200T: [2016](#) / [2017](#)
- IS250: [2014](#) / [2015](#)
- IS300: [2016](#) / [2017](#)
- IS350: [2014](#) / [2015](#) / [2016](#) / [2017](#)
- RC200T: [2016](#) / [2017](#)
- RC300: [2016](#) / [2017](#)
- RC350: [2015](#) / [2016](#) / [2017](#)
- RC F: [2015](#) / [2016](#) / [2017](#)

Figure 63.

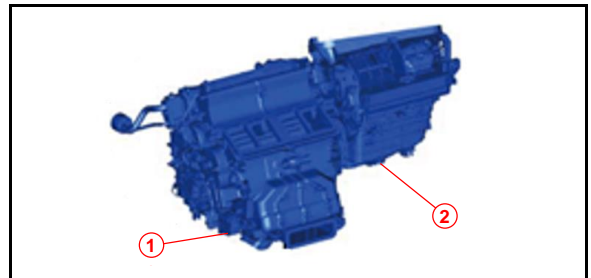

1	Air Conditioning Unit
2	Blower Assembly

HVAC Servo Motor Malfunction

Damper Servo Sub-assembly Replacement Procedure (continued)

Replacement Procedure Group C (Servos Replaced From A/C Unit Removed From Vehicle) (continued)

- B. Remove the three screws from the cover sub-assembly.

Figure 64.

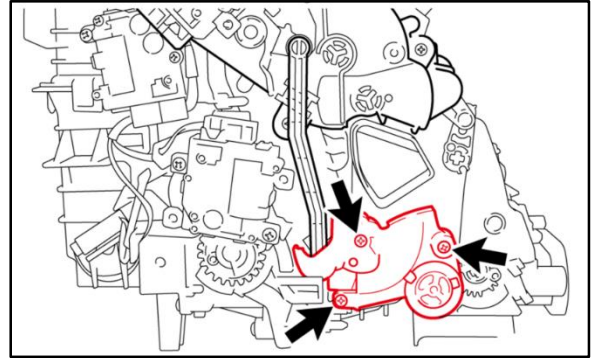

- C. Disconnect the connector and remove the three screws and servo.

NOTE

- Do NOT remove the screws on the servo body.
- Reuse the screws. If a screw is missing, order part number 90099-00968.

Figure 65.

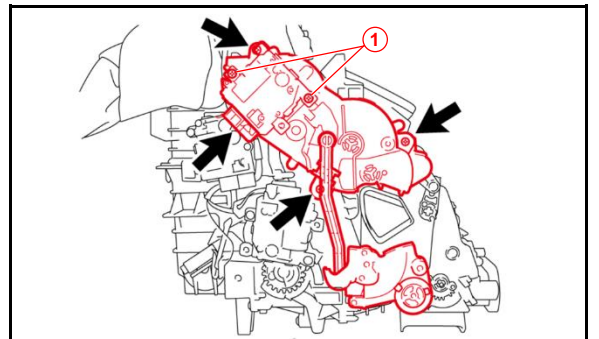

1	Do Not Remove
----------	----------------------

- D. Remove the [3] air outlet servo (D), heater damper control lever, and cover sub-assembly from the HVAC box and place them on a work bench.

- E. Disengage the claw and remove the cover sub-assembly.

NOTE

Do NOT discard the screws and the cover sub-assembly as they will be reused.

Figure 66.

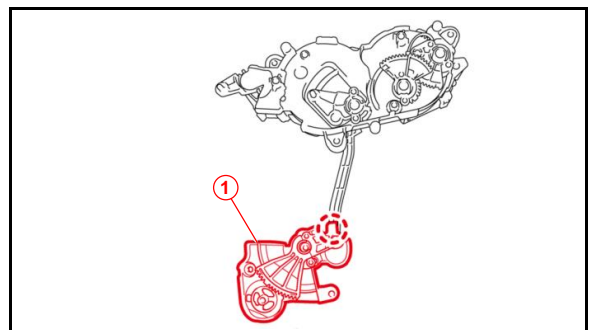

1	Cover Sub-Assembly
----------	---------------------------

HVAC Servo Motor Malfunction

Damper Servo Sub-assembly Replacement Procedure (continued)

Replacement Procedure Group C (Servos Replaced From A/C Unit Removed From Vehicle) (continued)

- F. Mark and store the removed servo and lever in a separate container to avoid reinstalling them in error.

NOTE

Replace the heater air damper control lever as it may become damaged during removal (part number 87296-53010).

Figure 67.

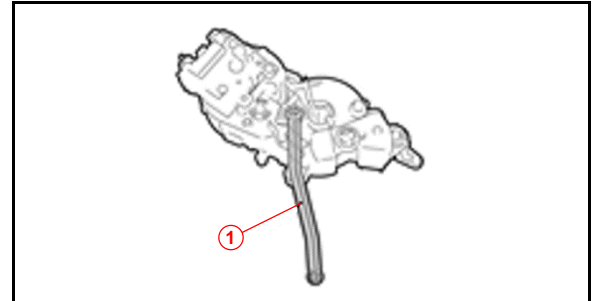

1	Lever
----------	--------------

- G. Install the NEW [3] air outlet servo (D) (W/lever type) by turning the gear by hand to align the match marks.

NOTE

The mark on the air conditioning unit side can be found at the inner part of the housing surface.

Figure 68.

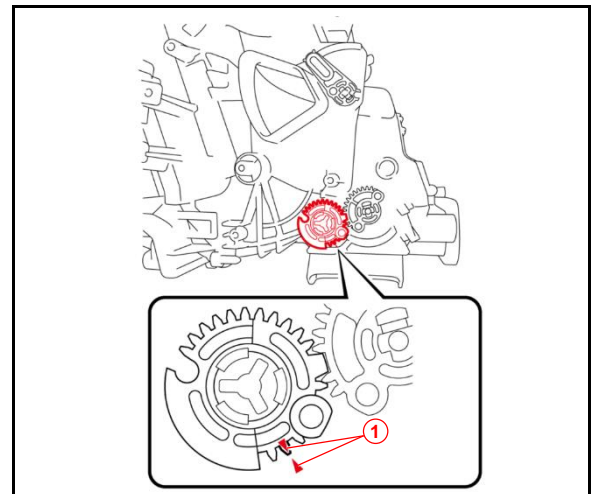

1	Match Mark
----------	-------------------

HVAC Servo Motor Malfunction

Damper Servo Sub-assembly Replacement Procedure (continued)

Replacement Procedure Group C (Servos Replaced From A/C Unit Removed From Vehicle) (continued)

- H. Align the peephole with the big tooth of the gear attached to the cover sub-assembly and temporarily install the cover sub-assembly.
- I. Look through the peephole to confirm that the big tooth is aligned with the tooth-missed part of the gear, then install the cover sub-assembly with the three screws.

NOTE

The gear can be moved with ease if the cover sub-assembly is installed at the correct position.

Figure 69.

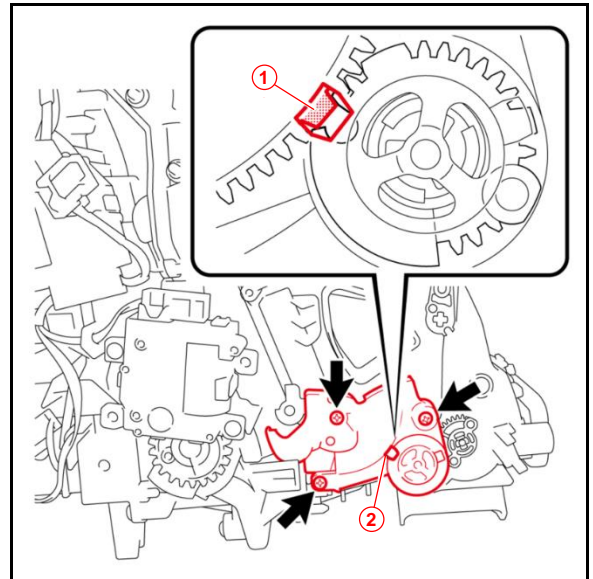

1	Big Tooth
2	Peephole

HVAC Servo Motor Malfunction

Damper Servo Sub-assembly Replacement Procedure (continued)

Replacement Procedure Group C (Servos Replaced From A/C Unit Removed From Vehicle) (continued)

- J. For installation of the [3] air outlet servo (D) (W/lever type), align the tooth-missed part of the gear with the mark, and position the two levers in between the two marks.

NOTE

- The mark on the air conditioning unit side can be found at the inner part of the housing surface.
- Be careful of the level positions as they may move due to the weight of the door.

Figure 70.

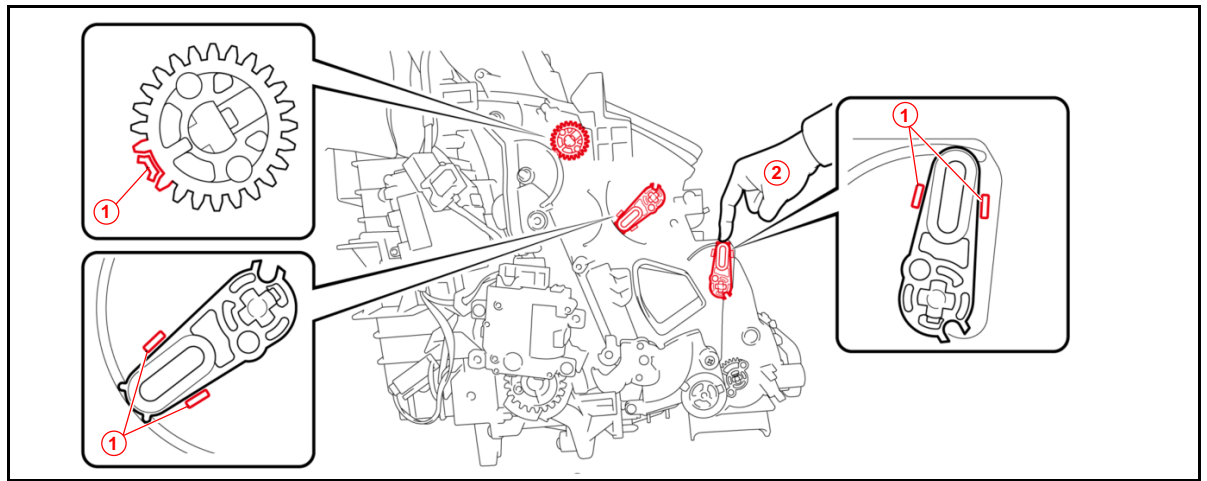

1	Mark
2	Hold

HVAC Servo Motor Malfunction

Damper Servo Sub-assembly Replacement Procedure (continued)

Replacement Procedure Group C (Servos Replaced From A/C Unit Removed From Vehicle) (continued)

- K. Temporarily install the NEW [3] air outlet servo (D) (W/lever type) while adjusting the positions of the gear and lever.
- L. Looking down from above, confirm that the pins of the servo are inserted into the holes of the two levers.
- M. Install the NEW [3] air outlet servo (D) (W/lever type) with the three screws.
- N. Reconnect the connector.

Figure 71.

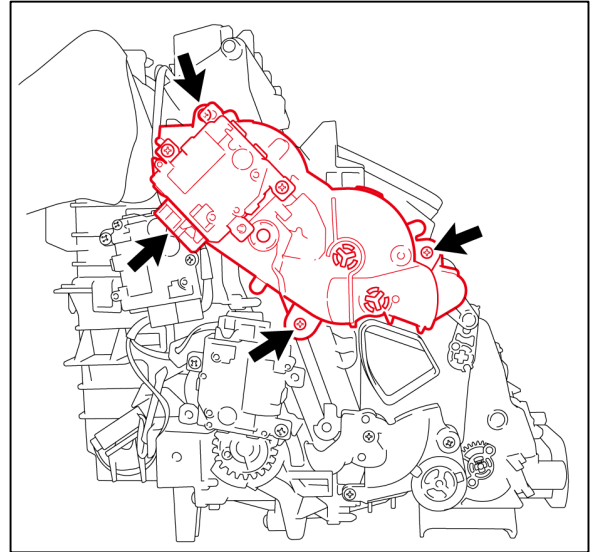

- O. Install the NEW heater air damper control lever by engaging the end claws into the cover sub-assembly and servo.

NOTE

Make sure to install the lever into the cover sub-assembly first, then into the servo. The lever will be locked and will NOT move if it is installed into the servo first.

Figure 72.

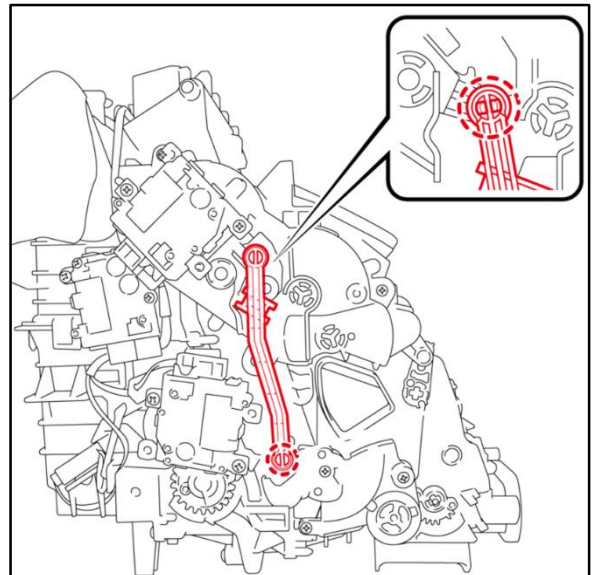

HVAC Servo Motor Malfunction

Damper Servo Sub-assembly Replacement Procedure (continued)

Replacement Procedure Group C (Servos Replaced From A/C Unit Removed From Vehicle) (continued)

P. Install the air conditioning unit.

Refer to TIS, applicable model and model year Repair Manual:

Vehicle Interior – Heating/Air Conditioning – “Heating / Air Conditioning:
Air Conditioning Unit: Installation”

- IS200T: [2016](#) / [2017](#)
- IS250: [2014](#) / [2015](#)
- IS300: [2016](#) / [2017](#)
- IS350: [2014](#) / [2015](#) / [2016](#) / [2017](#)
- RC200T: [2016](#) / [2017](#)
- RC300: [2016](#) / [2017](#)
- RC350: [2015](#) / [2016](#) / [2017](#)
- RC F: [2015](#) / [2016](#) / [2017](#)

Q. Is this the last servo being replaced?

- **YES** — [Continue to the Completion Procedure.](#)
- **NO** — [Go to the next servo replacement procedure.](#)

HVAC Servo Motor Malfunction

Damper Servo Sub-assembly Replacement Procedure (continued)

Replacement Procedure Group C (Servos Replaced From A/C Unit Removed From Vehicle) (continued)

Figure 73. [3] Air Outlet Servo (D)

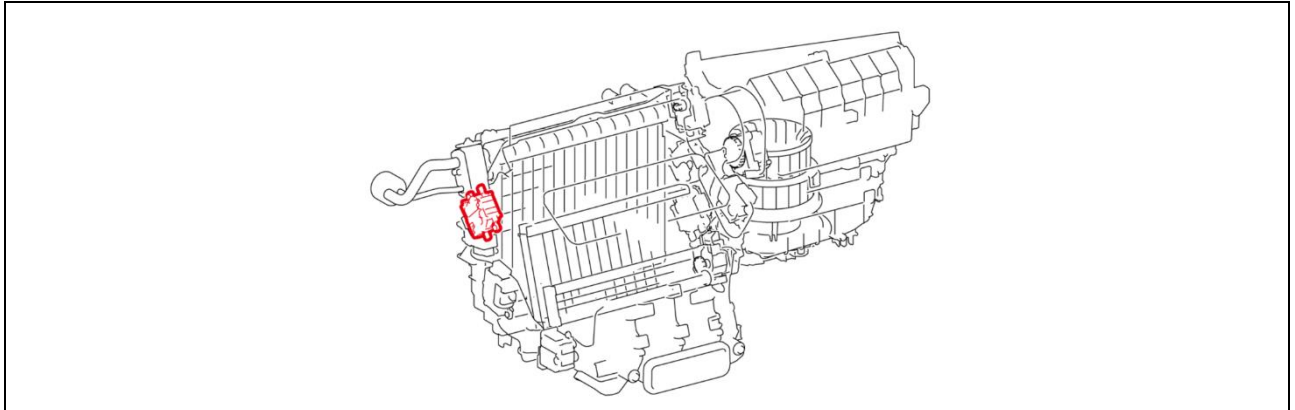

5. Remove the [3] air outlet servo (D) – DTC B1443 (W/O lever type) (GS ONLY).

- A. Remove the air conditioning unit and blower assembly from the vehicle together as an assembly.

Refer to TIS, applicable model and model year Repair Manual:

*Vehicle Interior –
Heating/Air Conditioning –
“Heating / Air Conditioning:
Air Conditioning Unit: Removal”*

- GS200T: [2016](#) / [2017](#)
- GS350: [2013](#) / [2014](#) / [2015](#) / [2016](#) / [2017](#)
- GS450H: [2013](#) / [2014](#) / [2015](#) / [2016](#) / [2017](#)
- GS F: [2016](#) / [2017](#)

Figure 74.

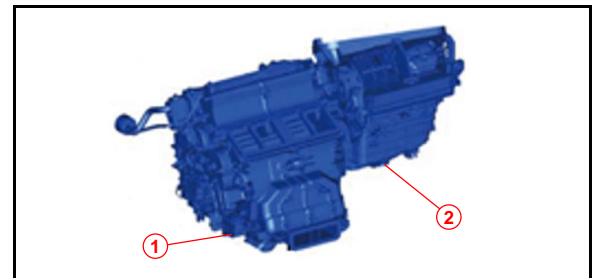

1	Air Conditioning Unit
2	Blower Assembly

HVAC Servo Motor Malfunction

Damper Servo Sub-assembly Replacement Procedure (continued)

Replacement Procedure Group C (Servos Replaced From A/C Unit Removed From Vehicle) (continued)

- B. Disconnect the connector and remove the three screws.

NOTE

Reuse the screws. If a screw is missing, order part number 90099-00968.

Figure 75.

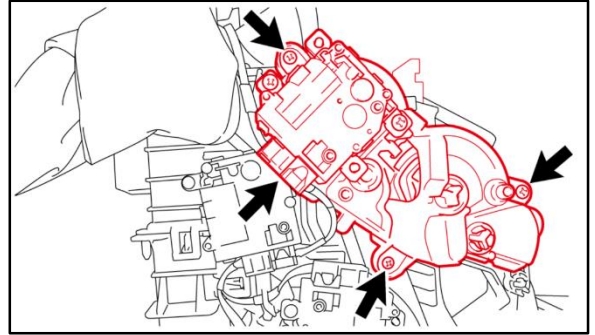

- C. Mark and store the removed servo in a separate container to avoid reinstalling it in error.
- D. Install the NEW [3] air outlet servo (D) (W/O lever type) by aligning the tooth-missed part of the gear with the mark, and position the two levers in between the two marks.

NOTE

- The mark on the air conditioning unit side can be found at the inner part of the housing surface.
- Be careful of the level positions as they may move due to the weight of the door.

Figure 76.

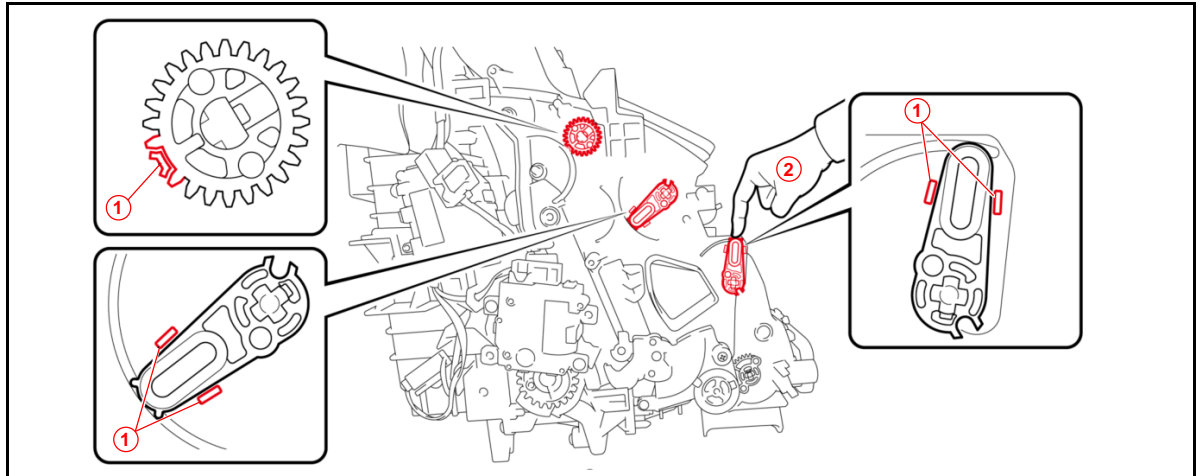

1	Mark
2	Hold

HVAC Servo Motor Malfunction

Damper Servo Sub-assembly Replacement Procedure (continued)

Replacement Procedure Group C (Servos Replaced From A/C Unit Removed From Vehicle) (continued)

- E. Temporarily install the NEW [3] air outlet servo (D) (W/O lever type) while adjusting the positions of the gear and lever.
- F. Looking down from above, confirm that the pins of the servo are inserted into the holes of the two levers.
- G. Install the NEW servo with the three screws.

Figure 77.

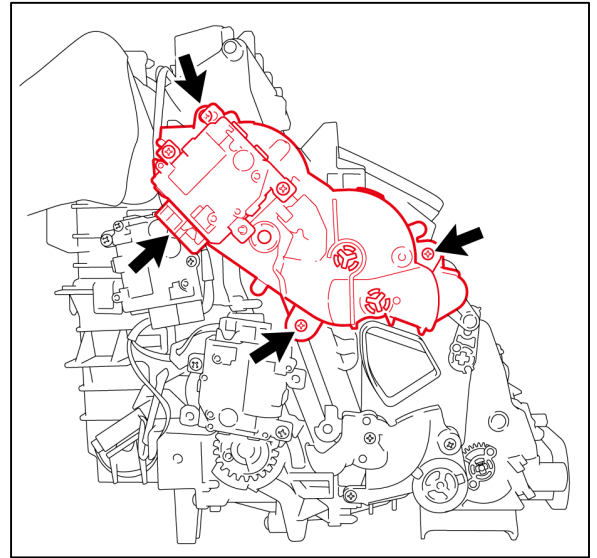

- H. Reconnect the connector.

- I. Install the air conditioning unit.

Refer to TIS, applicable model and model year Repair Manual:

Vehicle Interior – Heating / Air Conditioning – “Heating / Air Conditioning: Air Conditioning Unit: Installation”

- GS200T: [2016](#) / [2017](#)
- GS350: [2013](#) / [2014](#) / [2015](#) / [2016](#) / [2017](#)
- GS450H: [2013](#) / [2014](#) / [2015](#) / [2016](#) / [2017](#)
- GS F: [2016](#) / [2017](#)

- J. Is this the last servo being replaced?

- **YES** — [Go to the Completion Procedure.](#)
- **NO** — [Go to the next servo replacement procedure.](#)

HVAC Servo Motor Malfunction

Damper Servo Sub-assembly Replacement Procedure (continued)

Replacement Procedure Group C (Servos Replaced From A/C Unit Removed From Vehicle) (continued)

Figure 78. [10] DEF A/O Servo (D)

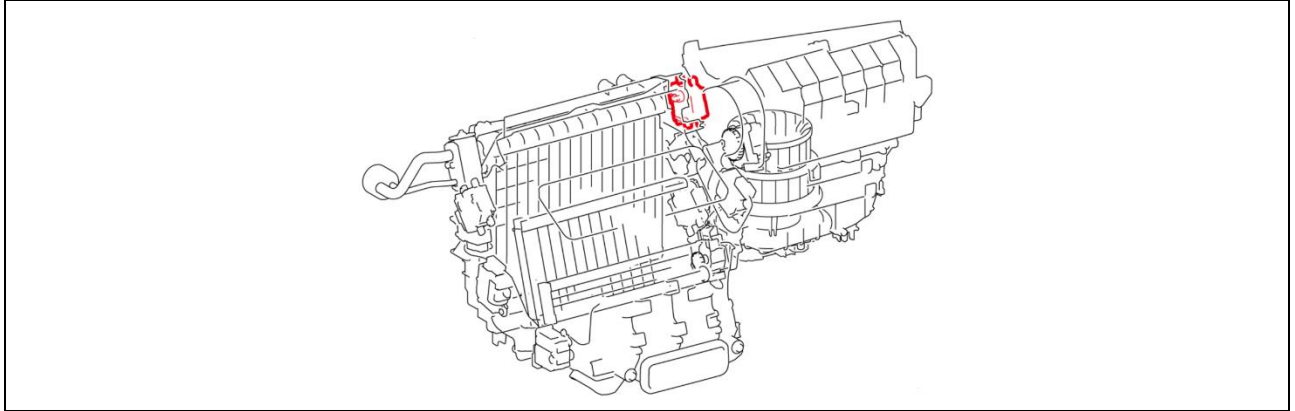

6. Remove the [10] DEF A/O servo (D) – DTC B1455.

- A. Remove the air conditioning unit and blower assembly from the vehicle together as an assembly.

Refer to TIS, applicable model and model year Repair Manual:

*Vehicle Interior –
Heating/Air Conditioning –
“Heating / Air Conditioning:
Air Conditioning Unit: Removal”*

Figure 79.

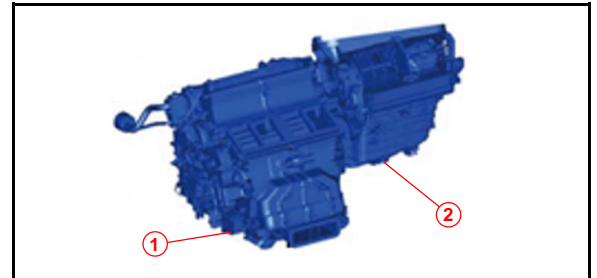

1	Air Conditioning Unit
2	Blower Assembly

- IS200T: [2016](#) / [2017](#)
- IS250: [2014](#) / [2015](#)
- IS300: [2016](#) / [2017](#)
- IS350: [2014](#) / [2015](#) / [2016](#) / [2017](#)
- RC200T: [2016](#) / [2017](#)
- RC300: [2016](#) / [2017](#)
- RC350: [2015](#) / [2016](#) / [2017](#)
- RC F: [2015](#) / [2016](#) / [2017](#)
- GS200T: [2016](#) / [2017](#)
- GS350: [2013](#) / [2014](#) / [2015](#) / [2016](#) / [2017](#)
- GS450H: [2013](#) / [2014](#) / [2015](#) / [2016](#) / [2017](#)
- GS F: [2016](#) / [2017](#)

HVAC Servo Motor Malfunction

Damper Servo Sub-assembly Replacement Procedure (continued)

Replacement Procedure Group C (Servos Replaced From A/C Unit Removed From Vehicle) (continued)

- B. Disconnect the connector and remove the two screws.

NOTE

Reuse the screws. If a screw is missing, order part number 90099-00968.

Figure 80.

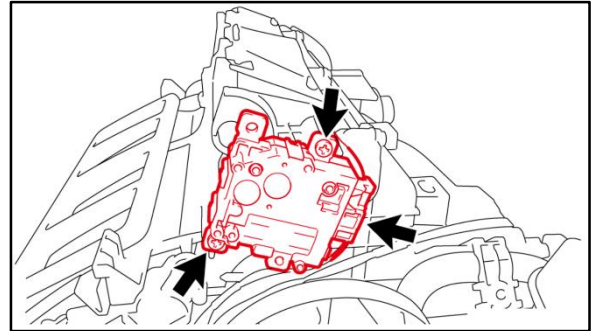

- C. Insert a screwdriver wrapped in protective tape between the gap of the servo and gear and remove the servo.

NOTE

The gear remains on the air conditioning unit side.

Figure 81.

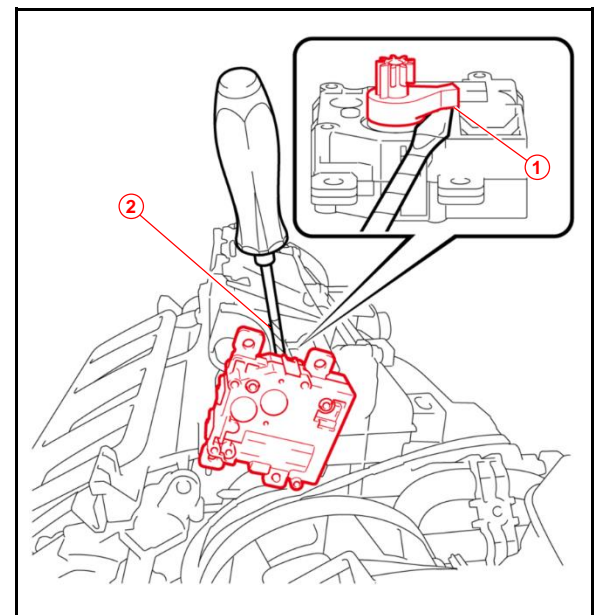

1	Insertion Point
2	Protective Tape

HVAC Servo Motor Malfunction

Damper Servo Sub-assembly Replacement Procedure (continued)

Replacement Procedure Group C (Servos Replaced From A/C Unit Removed From Vehicle) (continued)

D. Turn the gear by hand to remove it.

Figure 82.

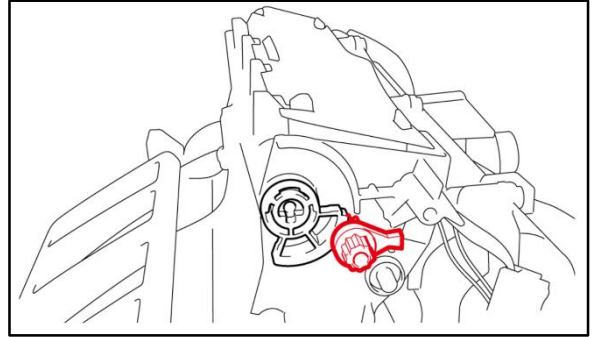

E. Mark and store the removed servo and servo gear in a separate container to avoid reinstalling them in error.

F. Install the NEW [10] DEF A/O servo (D). Turn the gear by hand to line it up with the mark on the air conditioning unit.

Figure 83.

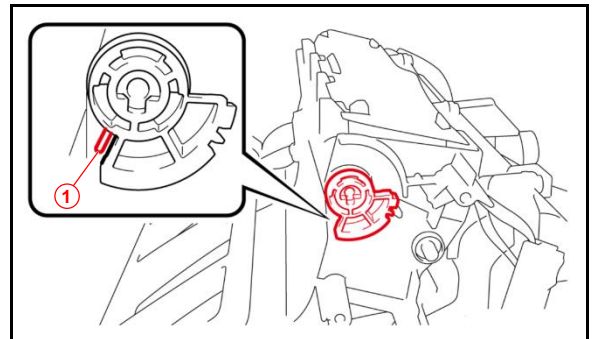

1	Mark
----------	-------------

HVAC Servo Motor Malfunction

Damper Servo Sub-assembly Replacement Procedure (continued)

Replacement Procedure Group C (Servos Replaced From A/C Unit Removed From Vehicle) (continued)

- G. Align the long teeth of the servo gear with the teeth of the gear, and temporarily install the NEW servo.

- H. Install the NEW servo with the two screws and reconnect the connector.

Figure 84.

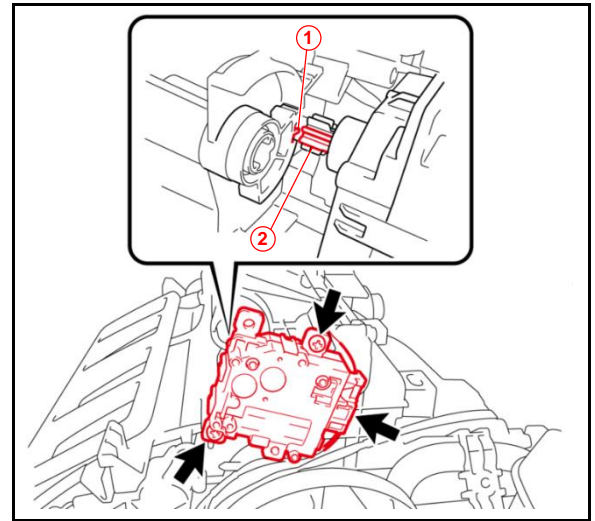

1	Alignment Location
2	Long Teeth

- I. Reinstall the air conditioning unit.

Refer to TIS, applicable model and model year Repair Manual:

Vehicle Interior – Heating/Air Conditioning – “Heating / Air Conditioning: Air Conditioning Unit: Installation”

- IS200T: [2016](#) / [2017](#)
- IS250: [2014](#) / [2015](#)
- IS300: [2016](#) / [2017](#)
- IS350: [2014](#) / [2015](#) / [2016](#) / [2017](#)
- RC200T: [2016](#) / [2017](#)
- RC300: [2016](#) / [2017](#)
- RC350: [2015](#) / [2016](#) / [2017](#)
- RC F: [2015](#) / [2016](#) / [2017](#)
- GS200T: [2016](#) / [2017](#)
- GS350: [2013](#) / [2014](#) / [2015](#) / [2016](#) / [2017](#)
- GS450H: [2013](#) / [2014](#) / [2015](#) / [2016](#) / [2017](#)
- GS F: [2016](#) / [2017](#)

HVAC Servo Motor Malfunction

Damper Servo Sub-assembly Replacement Procedure (continued)

Replacement Procedure Group C (Servos Replaced From A/C Unit Removed From Vehicle) (continued)

- J. Is this the last servo being replaced?
- **YES** — [Continue to the Completion Procedure.](#)
 - **NO** — [Go to the next servo replacement procedure.](#)

Completion Procedure

1. Initialize the servo(s).

Refer to TIS, applicable model and model year Repair Manual:

Vehicle Interior – Heating/Air Conditioning – “Heating / Air Conditioning: Air Conditioning System: Initialization”

- IS200T: [2016](#) / [2017](#)
 - IS250: [2014](#) / [2015](#)
 - IS300: [2016](#) / [2017](#)
 - IS350: [2014](#) / [2015](#) / [2016](#) / [2017](#)
 - RC200T: [2016](#) / [2017](#)
 - RC300: [2016](#) / [2017](#)
 - RC350: [2015](#) / [2016](#) / [2017](#)
 - RC F: [2015](#) / [2016](#) / [2017](#)
 - GS200T: [2016](#) / [2017](#)
 - GS350: [2013](#) / [2014](#) / [2015](#) / [2016](#) / [2017](#)
 - GS450H: [2013](#) / [2014](#) / [2015](#) / [2016](#) / [2017](#)
 - GS F: [2016](#) / [2017](#)
2. Check for DTCs.
 3. If the servo does NOT function correctly, replace it.
 4. Restore the vehicle back to its assembled condition.