



# SERVICE BULLETIN

Classification: FA99-001e	Reference: NTB99-001e	Date: February 12, 2021
------------------------------	--------------------------	----------------------------

## STRUT AND SHOCK ABSORBER REPLACEMENT GUIDELINES

This bulletin has been amended. See **AMENDMENT HISTORY** on the last page. Please discard previous versions of this bulletin.

**APPLIED VEHICLES:** All 1990-2021 Nissan vehicles except those listed below

This bulletin **does not apply to:**

All GT-R (R35) vehicles

Armada (TA60 and Y62) – vehicles equipped with rear-leveling air suspension

### SERVICE INFORMATION

This bulletin provides information to identify:

- A leaking strut or a shock absorber that qualifies for replacement under warranty.
- A strut or shock absorber that has slight oil seepage, a condition which is considered normal, does not affect strut/shock absorber operation or performance, and does not require replacement.
- A strut or shock absorber that should be replaced due to rod resistance/noise issues.

### IMPORTANT:

- If strut/shock absorber leakage is diagnosed in one strut/shock absorber, do **NOT** automatically replace struts/shock absorbers on both sides. Replace the leaking strut/shock absorber only.
- In cases where diagnosis of a strut indicates part replacement and the labor operation states that it includes toe or alignment check/set, the alignment check/set must be supported with a printout from your alignment machine (i.e., “alignment printout”).

Nissan Bulletins are intended for use by qualified technicians, not 'do-it-yourselfers'. Qualified technicians are properly trained individuals who have the equipment, tools, safety instruction, and know-how to do a job properly and safely. NOTE: If you believe that a described condition may apply to a particular vehicle, DO NOT assume that it does. See your Nissan dealer to determine if this applies to your vehicle.

## Inspect the Condition of Oil Leakage

If oil does NOT extend beyond the spring seat or upper 1/2 of shock:

- This is **slight oil seepage**. The strut/shock absorber should NOT be replaced.

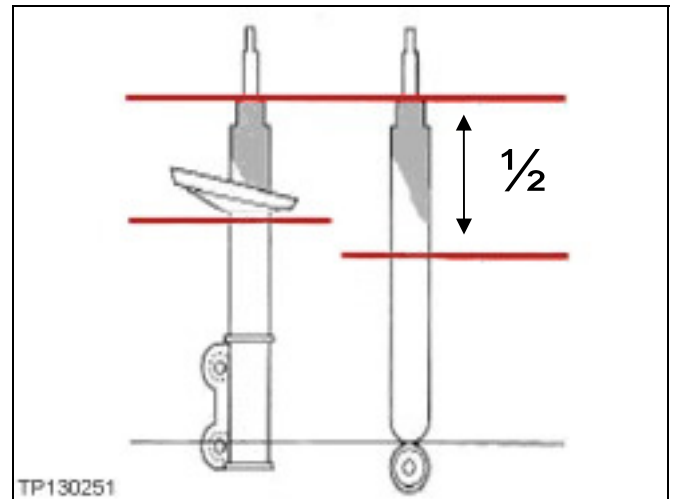

Figure 1

If oil does extend beyond the spring seat or upper 1/2 of shock:

- Use a finger to touch the oil that has extended beyond the spring seat or upper 1/2 of shock.

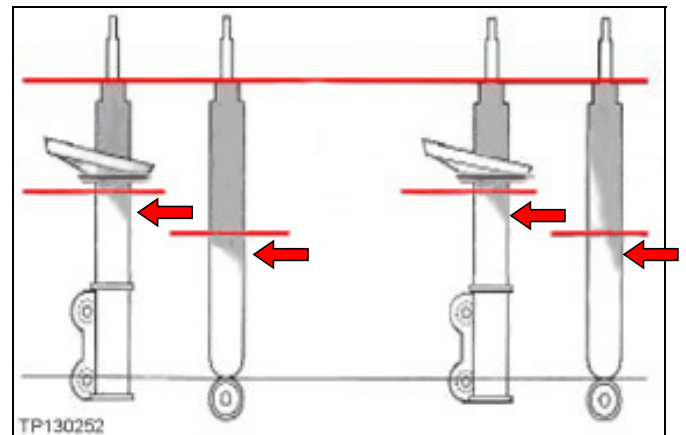

Figure 2

- If you confirm the oil layer is thick and contains large pieces of dust and debris, the strut/shock absorber **should be replaced**.

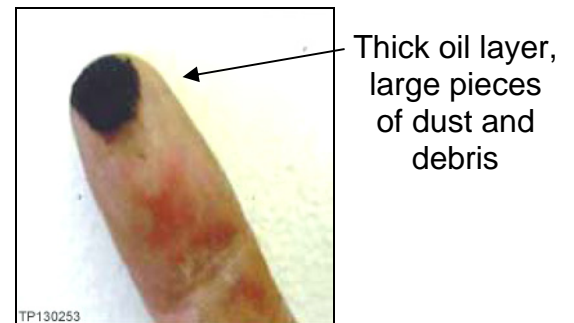

Figure 3

- If you confirm the oil layer is thin and does NOT contain large pieces of dust and debris, the strut/shock absorber should NOT be replaced.

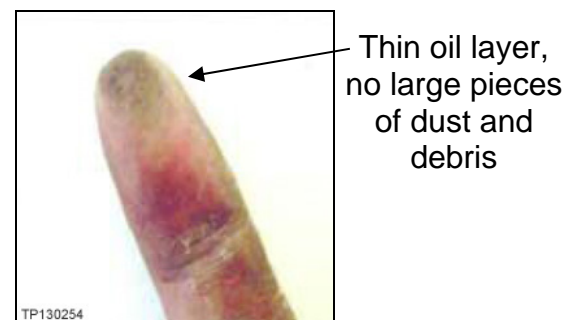

Figure 4

## Inspect the Strut/Shock Absorber Rod

**CAUTION:** The front shock absorbers for 2005 – 2021 Frontier (D40), 2005 – 2015 Xterra (N50), and 2005 - 2012 Pathfinder (R51) vehicles do NOT have a bound stopper inside. DO NOT fully compress the shock rod into the shock body. Make sure to stop the rod close to the end of travel when compressing during step 1.

1. Compress and extend the strut rod or shock absorber rod more than four (4) times by hand.
2. Confirm the resistance and sound is normal when operating.
  - If unusual resistance or sound is noted, the strut/shock absorber should be replaced.

### **AMENDMENT HISTORY**

<b>PUBLISHED DATE</b>	<b>REFERENCE</b>	<b>DESCRIPTION</b>
February 15, 1999	NTB99-001	Original bulletin published
March 19, 2013	NTB99-001a	Changes made throughout
September 22, 2017	NTB99-001b	APPLIED VEHICLES revised
–	NTB99-001c	Version not released
May 1, 2018	NTB99-001d	APPLIED VEHICLES and leakage criteria revised
February 12, 2021	NTB99-001e	APPLIED VEHICLES and CAUTION on page 3 revised