



Technical Service Bulletin

39 Four-wheel drive malfunction message, DTC C05ED00 is stored in the all-wheel drive control module

39 21 42 2051558/6 March 2, 2021. Supersedes Technical Service Bulletin Group 39 number 20-39 dated December 10, 2020 for reasons listed below.

Model(s)	Year	VIN Range	Vehicle-Specific Equipment
Q5, SQ5	2018	All	Quattro Ultra
Q5, SQ5	2019	000001 - 124125	Quattro Ultra
A6, A7, S6, and S7	2018 - 2019	All	Quattro Ultra
A6, A7, S6, and S7	2020	000001 - 008938	Quattro Ultra
A4, A4 allroad, and S4	2018	All	Quattro Ultra
A4, A4 allroad, and S4	2019	A000001 - A021502 Or N000001 - N001666	Quattro Ultra
A5, A5 Cabriolet. A5 Sportback, S5, S5 Cabriolet, and S5 Sportback	2018	All	Quattro Ultra
A5, A5 Cabriolet. A5 Sportback, S5, S5 Cabriolet, and S5 Sportback	2019	A000001 –A073698 Or N000001 - 010733	Quattro Ultra

Condition

REVISION HISTORY		
Revision	Date	Purpose
6	-	Revised <i>Required Parts and Tools</i> (Updated sealant quantity)
5	12/10/2020	Revised <i>Service</i> (Updated which ODIS test plan results to follow)



Technical Service Bulletin

4	08/22/2020	Revised <i>Service</i> (Updated instructions to reuse springs) Revised <i>Required Parts and Tools</i> (Updated Vise part number)
---	------------	--

Customer states:

- The message "four-wheel-drive malfunction" is sporadically shown in the instrument cluster.

Workshop findings:

The following DTC is logged in the all-wheel-drive control module, J492 (address word 0022):

- **DTC C05ED00** (4WD/AWD Clutch "B" Stuck Engaged) with symptom code 29725.

Technical Background

Quattro Ultra shift fork inside the rear differential is worn/faulty (Figure 1).



Figure 1. Worn/faulty shift fork.

Production Solution

Improved material in production.



Technical Service Bulletin

Service

Proceed as follows:

Complete the ODIS test plan for the **DTC C05ED00** (4WD/AWD Clutch "B" Stuck Engaged) completely according to Guided Fault Finding to rule out other reasons for the restricted function and to avoid an unnecessary parts replacement:

- If the result of the test plan leads to replacing the rear differential or finds no defect, perform a short test drive. If the same DTC returns after the test drive with the same symptom, the shift fork inside the rear differential is at fault and must be replaced. Perform the repair as follows. Do **not** replace the complete differential.
 - If the result of the test plan leads to replacing or repairing a different part (The All-Wheel Drive Clutch, Driveshaft Speed Sensor G970, All Wheel Drive Clutch Actuator 2 V623, or any other part), follow the Guided Fault Finding repair advice and this TSB does not apply.
1. Drain the oil of the rear differential according to the repair manual.
 2. Remove the rear differential per the repair manual.



Tip: Although there are instructions available in the Elsa repair manual to perform this repair, the tools utilized in Elsa have never been required tools. Our records indicate that few dealers have procured them as a result. The repair shown in this TSB uses tools that are minimum required tools and one tool that will be auto shipped to Audi dealers shortly. If you are missing a tool for this repair, please order it and continue with the repair.

At the time of publishing this TSB, we have enough tools in stock to handle these repairs/orders. If the web site shows no availability of a tool that you require, please call SBS directly at 1-800-892-9650 as they may have stock that is not showing on the site.

3. Place the differential on a workbench and remove the All-Wheel Drive Clutch Actuator 2 -V623- according to the repair manual.
4. Loosen the case bolts -1 to 9- and separate the housing halves saving the bolts as they will be reused for reassembly (Figure 2). Use care to not damage the sealing surfaces.

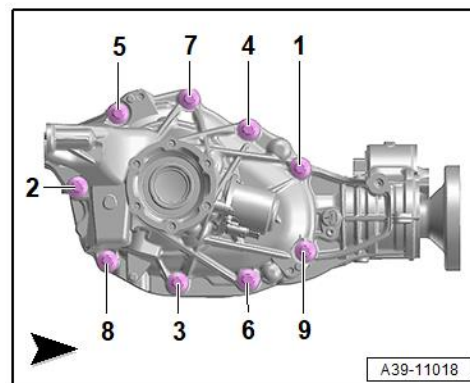

Figure 2. Case bolts.



Technical Service Bulletin

5. Mount the side carrier as shown below (Figure 3) to the VAS6095 using T40206, T40206/1A, one long slotted arm from the VAS6095, 3350/2 (Figure 4 and Figure 5), three M10 flat washers 2mm thick each (Figure 5), one M10 x 1.5 x70 bolt (Figure 4 and Figure 5), and one M12 x 1.5 x 38 bolt (Figure 4).



Figure 3. Mounted side carrier.



Technical Service Bulletin

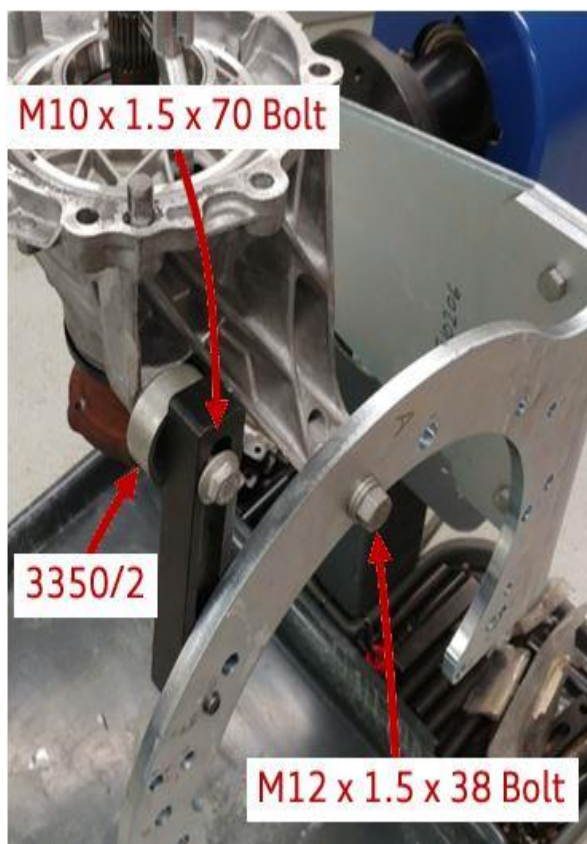

Figure 4. Mounting detail.

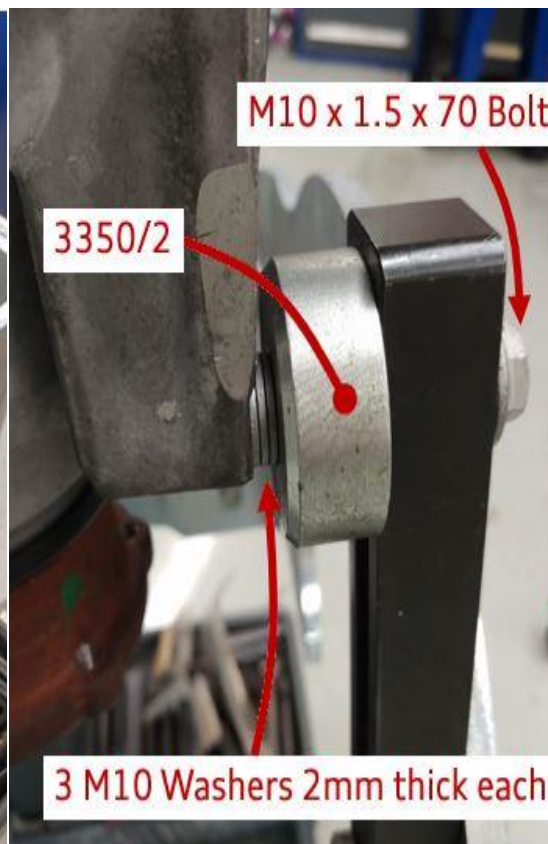

Figure 5. Mounting.

- 5a. The passenger side differential mount attaches to the T40206/1A at hole #6 and the long slotted arm of the VAS6095 attaches to threaded hole 5A using one of the M12 x 1.75 x 40 bolts from the VAS6095 engine/transmission stand (Figure 7). Alternately the long slotted arm of the VAS6095 can attach to threaded hole 5B with any M12 bolt and a nut (bolt must be 50mm or longer).



Technical Service Bulletin



Figure 6. Mounting.



Figure 7. Mounting.

6. Pull out the gear carrier (Figure 8, position 3) using the VAS 251001 with VAS 251 001/2 (Figure 8, position 1) and thrust piece 30 – 555 (Figure 8, position 2).

Alternate puller tool T10040 with T10040/2. This tool is harder to get jaws in the access holes but it will work.

Alternate thrust pieces can also be used and a test repair was performed not using a thrust piece. *If no thrust piece is used you may damage the end of the puller or the shaft if too much force is applied.*

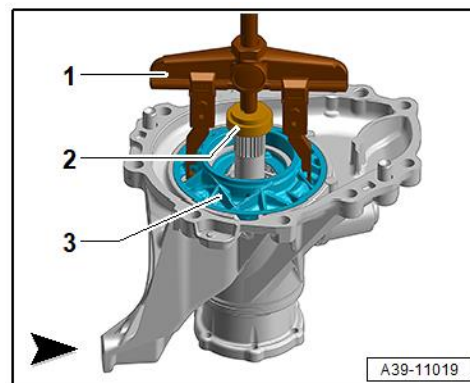

Figure 8. Puller arrangement.



Technical Service Bulletin

7. Remove the gear carrier (Figure 9, position 1 and Figure 10). During this step, guide the shift fork out of the clutch module (engagement collar), then remove the shim (Figure 9, position 2).

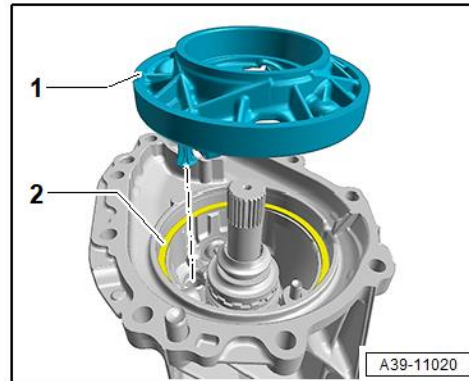

Figure 9. Gear carrier and shim removal.



Figure 10. Gear carrier removal.



Technical Service Bulletin

8. Remove the springs and save them for reinstallation (Figure 11, position 1).
Remove the roller sleeves (Figure 11, position 2).

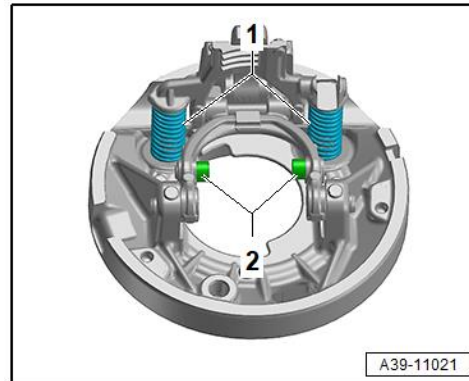

Figure 11. Shift fork assembly.

9. Install an M8 flange nut (Figure 12, position 3) onto the T10172/9 (Figure 12, position 4).

Tension the gear carrier in the vise as shown (Figure 12, position 1) using the plastic or brass soft jaws (Figure 12, 2). You may need a 2nd technician to assist you in holding the carrier.

Position the sleeve provided in the repair kit Part # 0B0 598 082 (Figure 12, position 6) between the shift fork (Figure 12, position 8).

Press out the bearing pin (Figure 12, position 5) until the thrust piece stops (Figure 12, position 4).

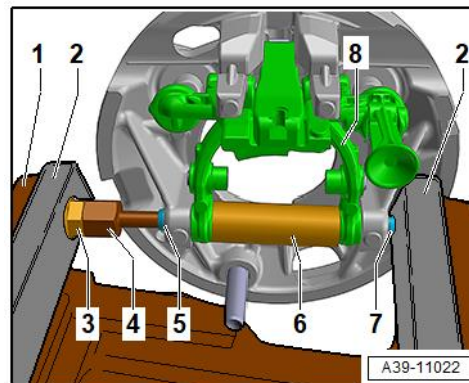

Figure 12. Pin removal.

The bearing pin (Figure 12, position 5) remains in the shift fork (Figure 12, position 8) together with the sleeve (Figure 12, position 6).

Repeat the procedure on the other side.



Technical Service Bulletin

10. Insert the pins (Figure 13, position 1) into the holes of the gear carrier.

The pins have to be easy to move in and out of the holes

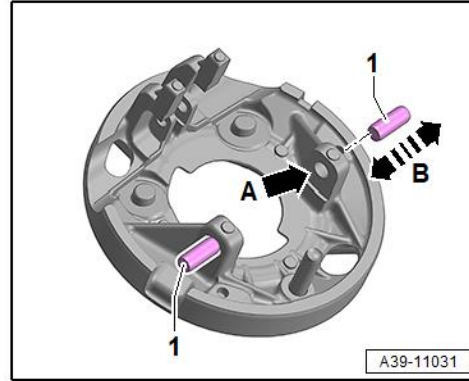

Figure 13. Pin checking.

11. Insert the new shift fork from the repair kit (Figure 14, position 2) into the gear carrier, and in doing so pay attention to the right installation position.

Flap the latch (Figure 14, position 1) outward for installation.

Insert the shift fork (Figure 14, position 2) into the recess of the gear carrier -arrow-.

Partially insert the new pins provided in the repair kit (Figure 14, position 3), to secure the shift fork for the next step (Figure 14, position 2).

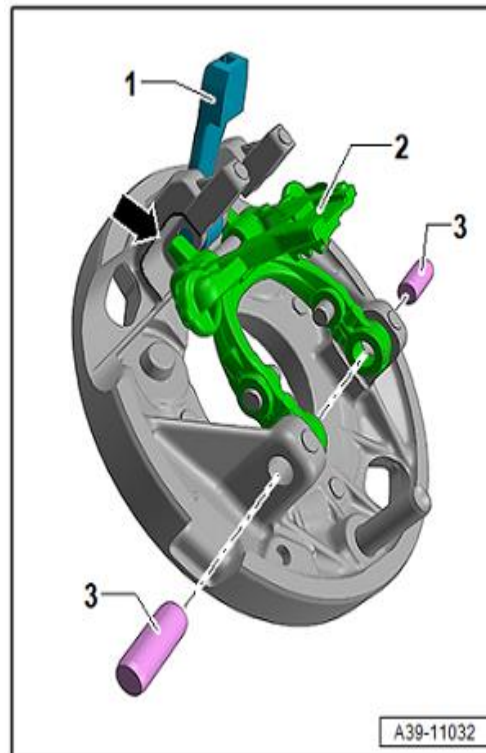

Figure 14. Installing a new shift fork.



Technical Service Bulletin

12. Pressing in the bearing pin with a vise using the plastic or brass soft jaws:

- Tension the gear carrier (Figure 15, position 2) and pin -5- as shown into the vise (Figure 15, position 4).
- Push in the pin (Figure 15, position 5) so far that it is flush with the inner side of the shift fork (Figure 15, position 1).
- Repeat the procedure on the other side.
- Check if the shift fork (Figure 15, position 1) can be swiveled with ease.

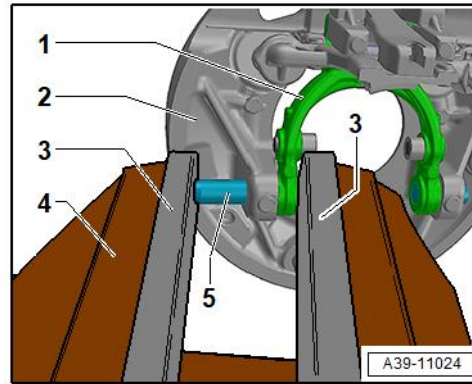

Figure 15. Pressing a pin with a vise.

12a Alternately, we realize not all shop vises will accept the procedure above. If your vise works you can proceed to step #13.

As a workable option, the minimum required tool 582277 Stud Remover can be used in place of a vise with T10172/9 with an M8 flange nut threaded on the T10172/9 (Figure 16).



Figure 16. Stud remover 582277.



Technical Service Bulletin

- 12b Insert the T10172/9 with the M8 flange nut as shown and the collared nut provides a solid surface to press the pin against (Figure 17).



Figure 17. T10172/9 installed in 582277.

- 12c. Set up the 582277 stud remover to press in the pin (Figure 18). The spindle might “walk” off-center and if it does loosen the spindle and center it again and continue pressing. You can also mount the body of the 582277 stud remover in a vise to steady it while pressing the pins. Press in one pin and then repeat on the opposite side.



Figure 18. Pin pressing with the 582277.



Technical Service Bulletin

13. Apply a small amount of assembly grease to the pins for the bushing and install the new bushings from the repair kit (Figure 19, position 2).

Reinstall the springs (Figure 19, position 1).

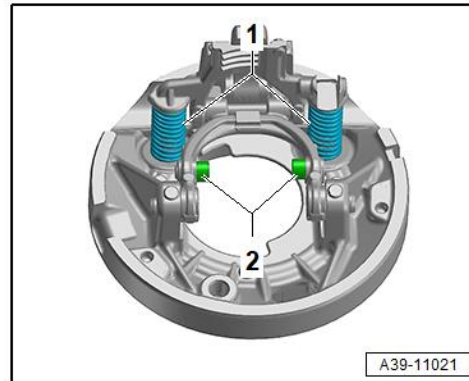

Figure 19. Bushing and spring installation.

14. Insert the shim (Figure 20, position 3).

If the coupling sleeve (Figure 21, position 3) is easily removed from the shaft, remove it, and insert it into the gear carrier (Figure 21). Pay attention that the sleeves (Figure 21, position 1) engage in to the groove of the coupling sleeve (Figure 21, position 3).

Insert the gear carrier (Figure 20, position 1) into the housing together with the coupling sleeve. Pay attention that the shock absorber (Figure 20, position 2), and the centering pin is correctly positioned to the housing (Figure 20, arrow).

If the coupling sleeve (Figure 21, position 3) is difficult to remove from the shaft you can raise it up the shaft and install it into the clutch module and install the gear carrier paying attention to the steps above.

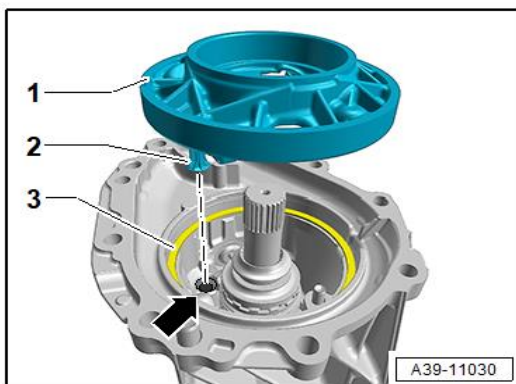

Figure 20. Shim and carrier installation.

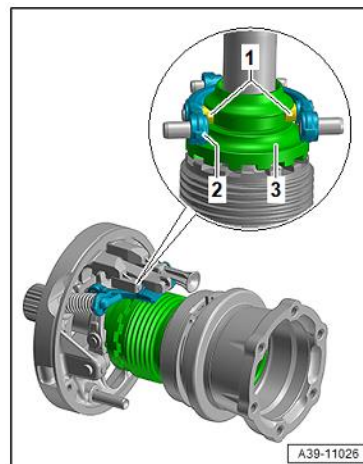

Figure 21. Detail of coupling installation.



Technical Service Bulletin

15. Remove the magnet (Figure 22, position 1), clean it, and re-insert.

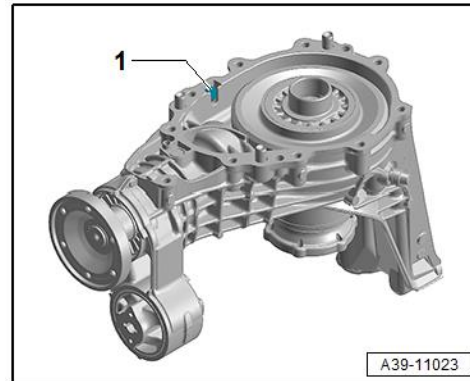

Figure 22. Magnet location.

16. Clean any oil and sealant residue off of the housing halves.

Apply the sealant (D 176 501 A1) onto the housing halves for the differential as shown (Figure 23).

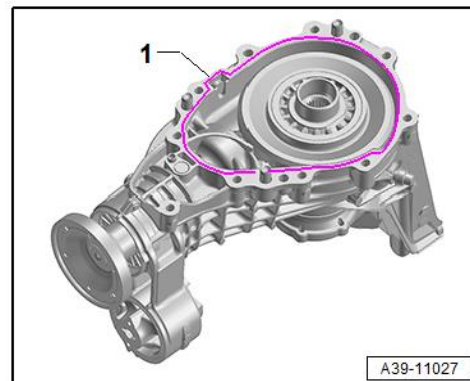

Figure 23. Sealant application.



Technical Service Bulletin

17. Reassemble the case halves.

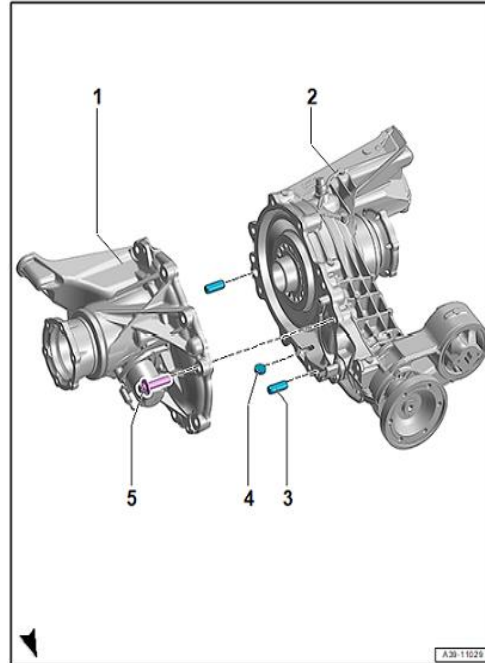

Figure 24. Case halves.

18. Install and torque the case bolts as follows and in the sequence shown (Figure 25):

- Install all the way by hand.
- Torque the bolts in sequence to 30 Nm.
- Turn each bolt an additional 45° in sequence.



Tip: The bolts for the differential case are reused.

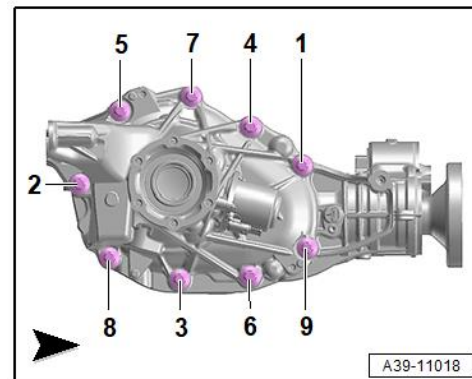

Figure 25. Tightening sequence.

19. Install the All-Wheel Drive Clutch Actuator 2 -V623- per the repair manual.
20. Install the differential into the vehicle per the repair manual.
21. Fill the differential with oil per the repair manual.
22. Clear faults and test drive to confirm the repair.



Technical Service Bulletin

Warranty

Claim Type:	<ul style="list-style-type: none"> • 110 up to 48 Months/50,000 Miles. • G10 for CPO Covered Vehicles – Verify Owner. • If the vehicle is outside any warranty, this Technical Service Bulletin is informational only. 		
Service Number:	3988		
Damage Code:	0016		
Labor Operations:	AWD final drive assembly remove + reinstall	3988 19XX	See SRT with associated operations
	Some models have associated labor operations for remove + reinstall AWD final drive assembly depending on their equipment	See Elsa	See SRT with associated operations
	Repair final drive (Replace Shift Fork)	3988 4199	130 TU
Diagnostic Time:	GFF	0150 0000	Time stated on the diagnostic protocol (Max 100 TU)
	Road test prior to service procedure	0121 0002	10 TU
	Road test after service procedure	0121 0004	10 TU
Claim Comment:	As per TSB #2051558/6		

All warranty claims submitted for payment must be in accordance with the *Audi Warranty Policies and Procedures Manual*. Claims are subject to review or audit by Audi Warranty.

Required Parts and Tools

Always check with your Parts Department and/or ETKA for the latest information and parts bulletins.		
Part Number	Part Description	Quantity
See ETKA	Fasteners, Bolts, Nuts, and Screws as needed per the Repair Manual	See ETKA/ELSA
0B0598082	Repair kit (selector fork)	01



Technical Service Bulletin

G 060190A2	Axle oil	01
D 176501A1	Sealant	0.5
M10	Flat washers (2mm thick each)	03

Tool Number	Tool Description
VAS6095	Engine Stand
T40206 with T40206/1	Gearbox Support
3350/2	Bearing Installer
N 10560702 or equivalent	Bolt M10 x 1.5 x 70
N 91041702 or equivalent	Bolt M12 x 1.5 x 38
VAS6095 engine stand bolt or equivalent	Bolt M12 x 1.75 x 40
VAS251001 with VAS251001/2 or T10040 with T10040/2	Two Arm Puller
T10172/9	Counter hold - Kit (multiple uses)
N 91182201 or equivalent	M8 flange nut
30 – 555 or equivalent	Press Piece - Pad
WIL745 or equivalent	Shop Vise
582277	Stud Remover (optional if needed)
VAS6095	Engine Stand

Additional Information

All parts and service references provided in this TSB (2051558) are subject to change and/or removal.

©2020 Audi of America, Inc. All rights reserved. Information contained in this document is based on the latest information available at the time of printing and is subject to the copyright and other intellectual property rights of Audi of America, Inc., its affiliated companies, and its licensors. All rights are reserved to make changes at any



Technical Service Bulletin

time without notice. No part of this document may be reproduced, stored in a retrieval system, or transmitted in any form or by any means, electronic, mechanical, photocopying, recording, or otherwise, nor may these materials be modified or reposted to other sites without the prior expressed written permission of the publisher.