



## TECHNICAL SERVICE BULLETIN

### Shifter Not Moving The Transmission To The Proper Gear Position

**21-2033**  
09 March 2021

#### Model:

<b>Ford</b> 2013-2018 C-MAX
2015-2018 Edge
2013-2016 Fusion
2014-2019 Escape
2013-2021 Transit Connect

**Issue:** Some 2013-2016 Fusion, 2013-2018 C-MAX, 2013-2019 Escape, 2014-2021 Transit Connect, and 2015-2018 Edge vehicles may indicate an incorrect shifter lever position. This may be due to the bushing at the transmission end of the shifter lever cable resulting in a mismatch of cluster and selected gear position. To correct the condition, follow the Service Procedure steps to replace the bushing and install the protective cap over the selector at the transmission end of the selector lever cable.

**Action:** Follow the Service Procedure to correct the condition on vehicles that meet the following criteria:

- One of the following vehicles:
  - 2013-2016 Fusion
  - 2013-2018 C-MAX
  - 2014-2019 Escape
  - 2013-2021 Transit Connect
  - 2015-2018 Edge
- At least one of the following symptoms:
  - Shifter not moving the transmission to proper shifter position
  - Damaged shifter bushing
  - Missing shifter bushing
  - Mismatch of cluster and selected gear position

**NOTE:** Part quantity refers to the number of that service part number required, which may be different than the number of individual pieces. Service part numbers contain 1 piece unless otherwise stated. "As Needed" indicates the part is required but the number may vary or is not a whole number; parts can be billed out as non-whole numbers, including less than 1.

#### Parts

Part Number	Description	Quantity
DG9Z-7K340-A	Shifter Cable Bushing	1
DG9Z-7S004-A	Protective Cap	1

**Warranty Status:** Eligible under provisions of New Vehicle Limited Warranty (NVLW)/Service Part Warranty (SPW)/Special Service Part (SSP)/Extended Service Plan (ESP) coverage. Limits/policies/prior approvals are not altered by a TSB. NVLW/SPW/SSP/ESP coverage limits are determined by the identified causal part and verified using the OASIS part coverage tool.

#### Labor Times

---

Description	Operation No.	Time
2013-2021 Transit Connect, 2014-2019 Escape/Escape Hybrid 2015-2018 Edge: Replace The Shift Cable Bushing Following The Service Procedure (Do Not Use With Any Other Labor Operations)	212033A	0.5 Hrs.
2013-2016 Fusion/Fusion Hybrid: Replace The Shift Cable Bushing Following The Service Procedure (Do Not Use With Any Other Labor Operations)	212033B	0.6 Hrs.
2015-2018 CMAX: Replace The Shift Cable Bushing Following The Service Procedure (Do Not Use With Any Other Labor Operations)	212033C	0.8 Hrs.

### Repair/Claim Coding

Causal Part:	7E395
Condition Code:	01

### Service Procedure

1. Access the cable at the transmission side by following the selector lever cable removal and installation procedure. Refer to WSM, Section 307-05.
2. Disconnect the selector lever cable from the transmission manual lever and the bracket. (Figure 1)
  - (1). Remove the selector lever cable bracket bolt.
  - (2). Disengage the selector lever cable holding clip. Use caution when removing the hold down bracket to avoid damage. Hold down bracket is available separate of the shift cable.
  - (3). Disconnect the selector lever cable.
    - Tighten to 7 Nm (62 lb-in)

Figure 1

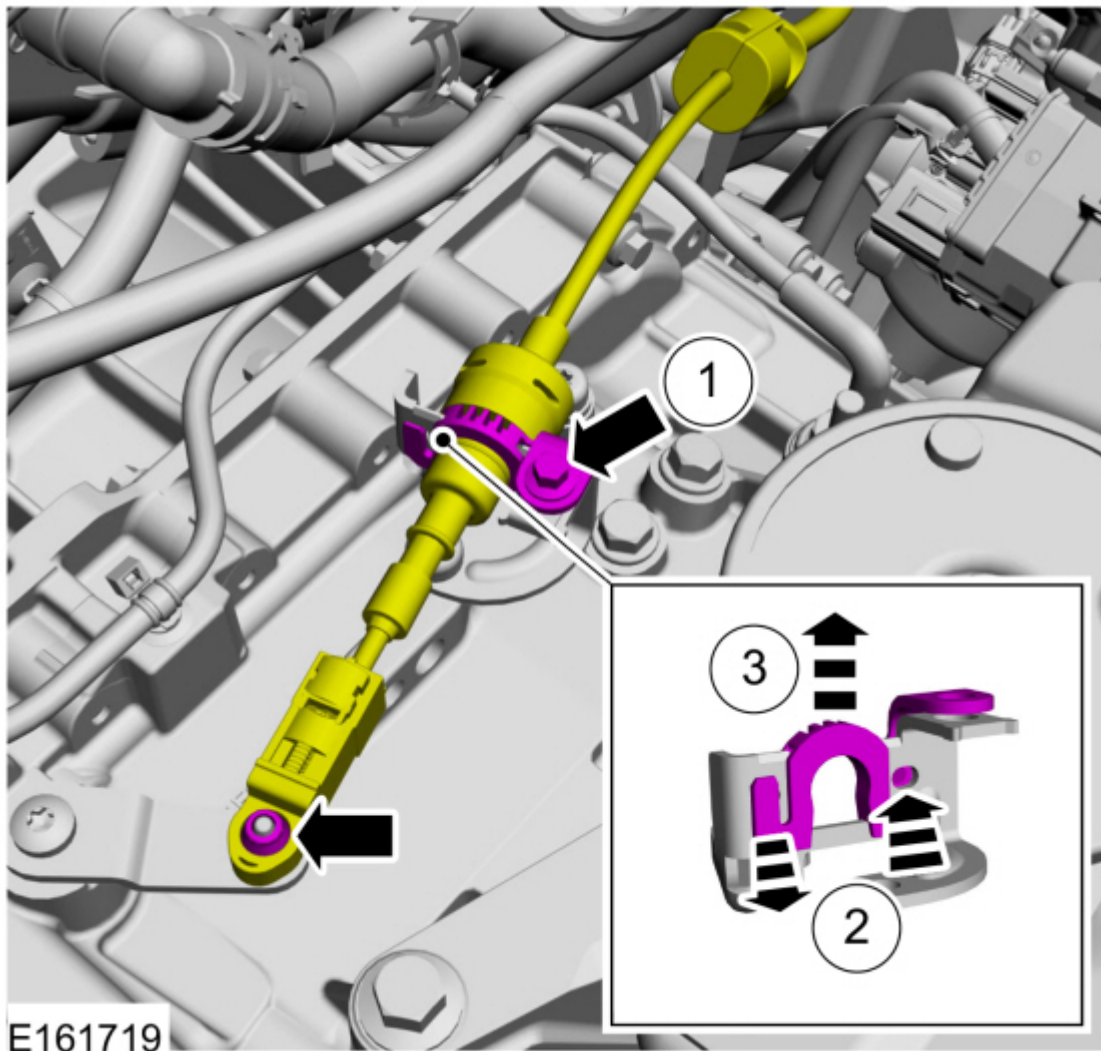

**NOTE:** Note the selector lever cable bushing replacement/orientation. (Figure 2)

Figure 2

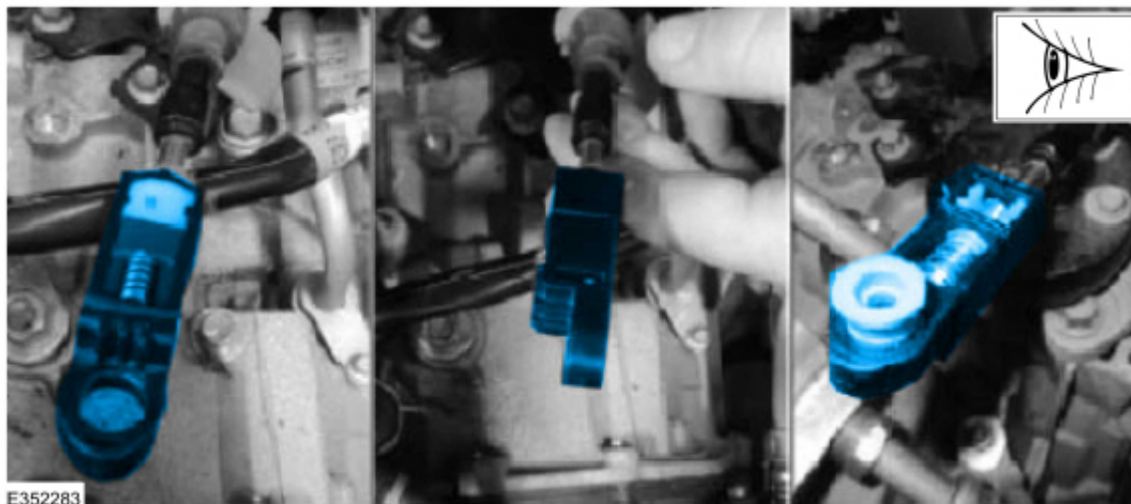

**⚠ CAUTION:** Use care to prevent damage to the shifter cable during this procedure.

### 3. Remove the shifter bushing.

(1). For 2013 vehicles only, use a pair of straight jaw adjustable pliers and a 15 mm shallow socket to push the bushing partially out of the selector lever cable end. (Figure 3)

**NOTE: The 15 mm socket will rest against the hard plastic bottom end of the shift cable and will be large enough to allow bushing to be pressed partially out.**

(2). Turn the selector lever cable end over and using a punch push the bushing the rest of the way out of the selector lever cable end. (Figure 4)



**CAUTION: Use care to prevent damage to the shifter cable during this procedure.**

**NOTE: For all 2013 vehicles equipped with original shift cable, the original bushing is taller than the replacement bushing.**

(3). For 2014-2016 vehicles only, press out the shifter cable bushing using one of the following two methods:

- Using a 5 mm and a 15 mm socket with straight jaw adjustable pliers, the bushing can be pressed out of the shifter cable end. The 5 mm socket will fit into the small part of the bushing on top, the 15 mm will go against the bottom of the shifter cable end, make sure to have socket centered with the bushing to allow clearance of the bushing shoulder as it is being pressed out. (Figures 5-6)
- Use a tool such as a Lisle 38350 - Exhaust Hanger Removal plier to press the bushing out. The shoulder of the bushing is positioned upward, small end of the plier is pressing the bushing out. (Figure 7)

Figure 3

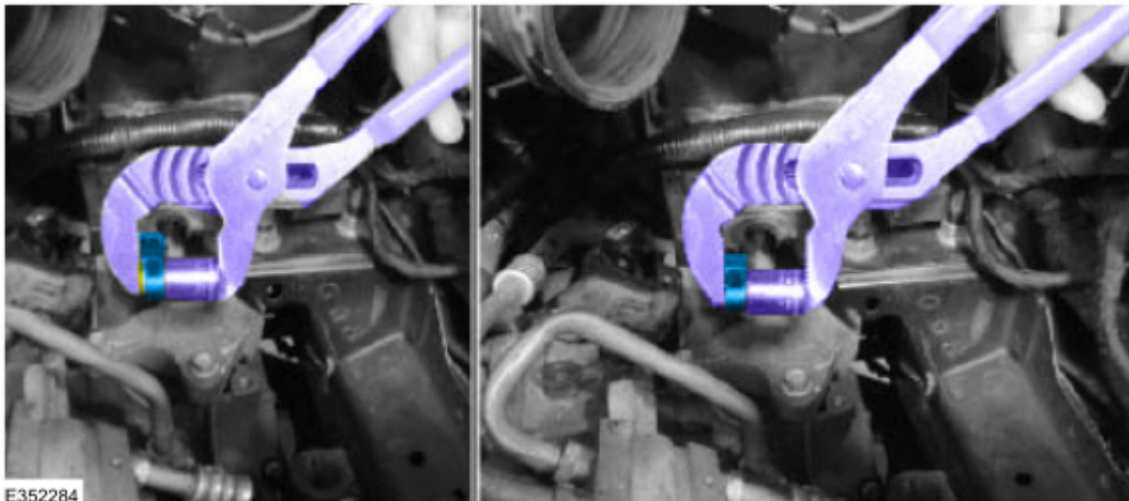

Figure 4

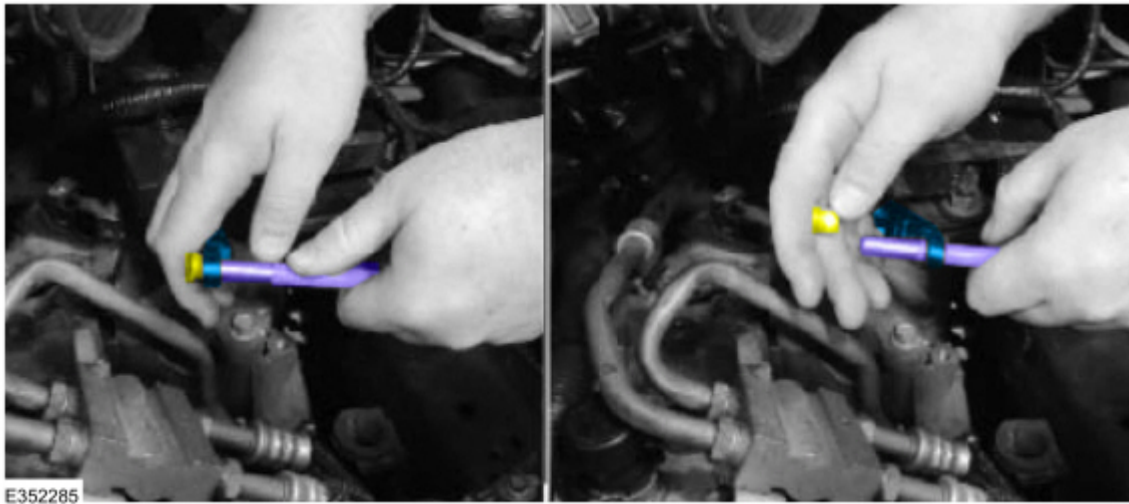

Figure 5

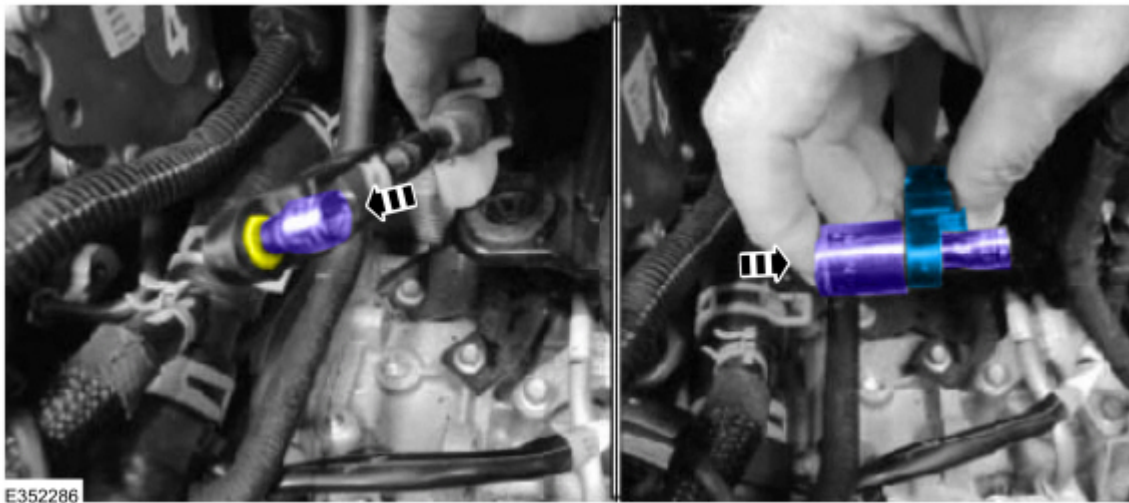

Figure 6

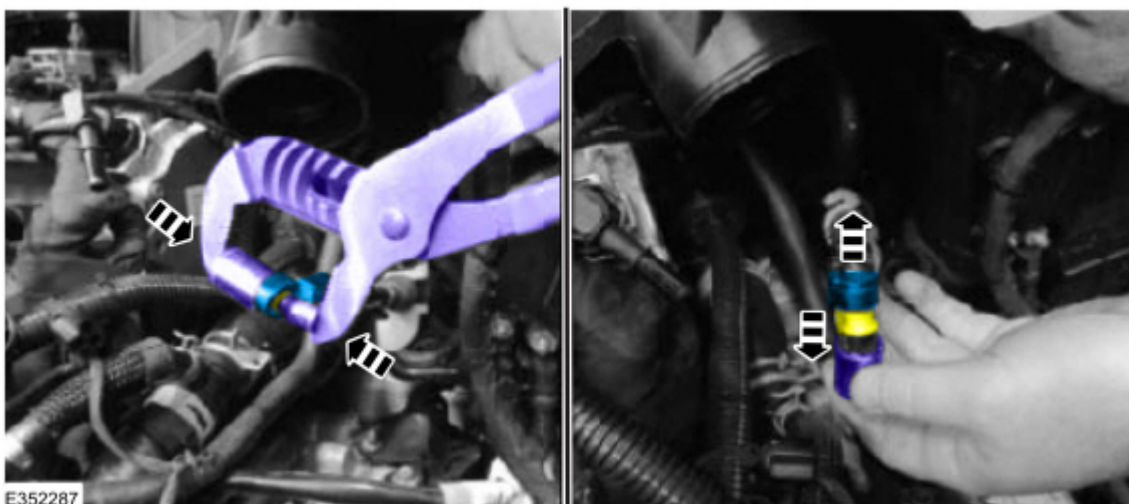

Figure 7



**⚠ CAUTION: Use care to prevent damage to the shifter cable during this procedure.**

4. Install the new selector lever cable bushing by hand. Do not use any grease to install, the bushing and cable end should be dry. (Figure 8)

Figure 8

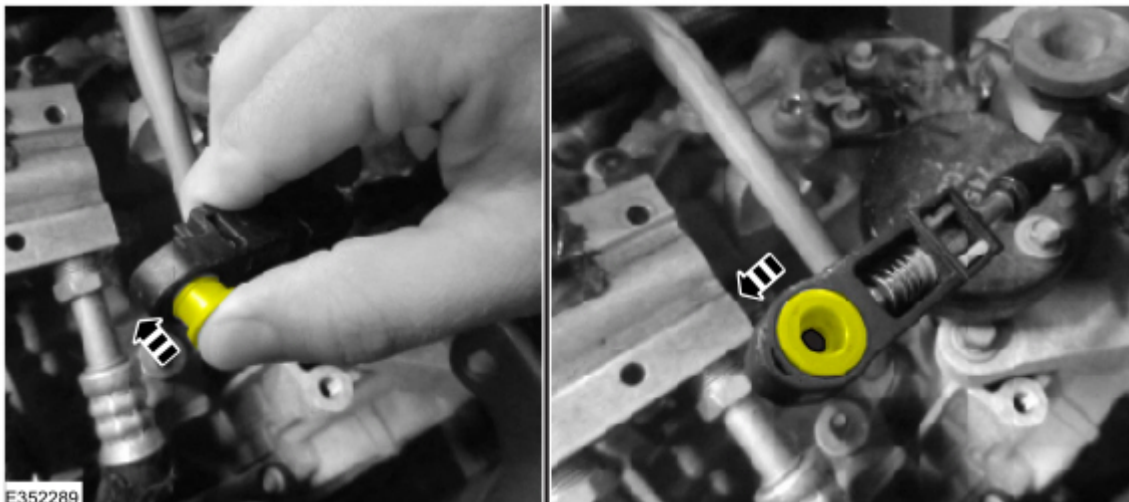

5. Visually inspect the shifter cable end for any signs of damage. If damage to the shifter cable end is found, replace the shifter cable.
6. Place the vehicle's transmission gear selector in DRIVE.
7. Rotate the manual control lever clockwise until it stops. (Figure 9)

Figure 9

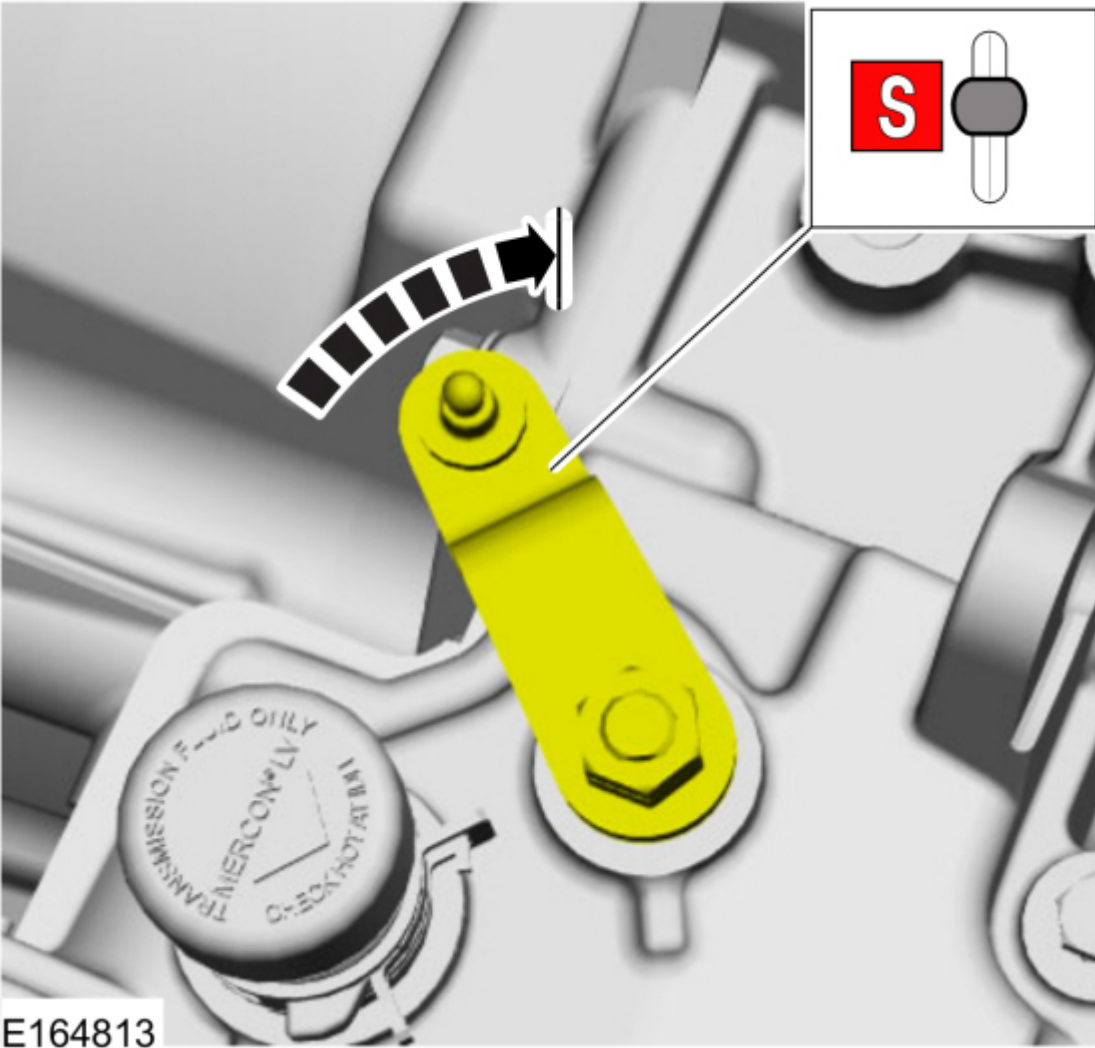

8. Rotate the manual control lever counterclockwise 1 detent into DRIVE. (Figure 10)  
Figure 10

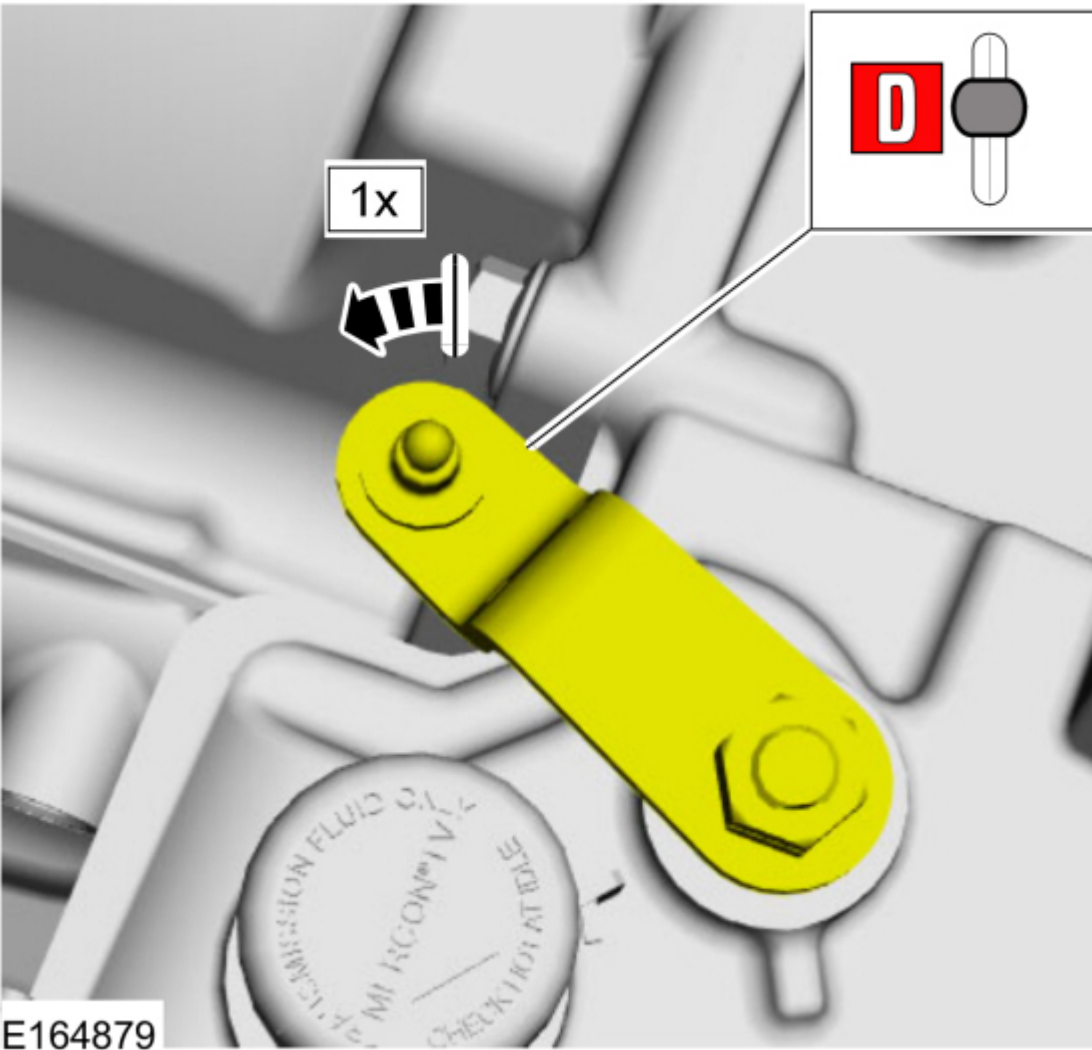

**9. Release the selector lever cable adjuster lock. (Figure 11)**

(1). Carefully release the adjuster lock tabs outward.

(2). While holding the adjuster lock tabs outward, slide the lock out to unlock the selector lever cable.

Figure 11



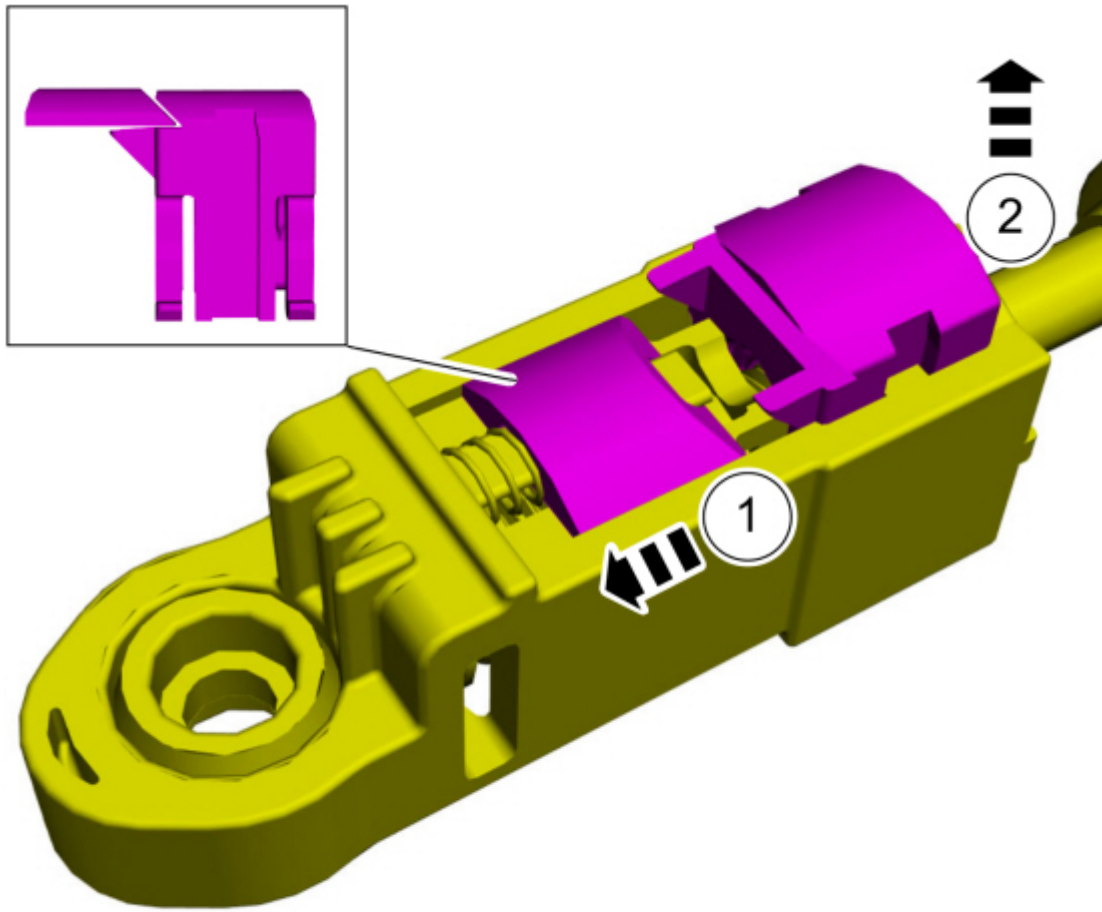

E164715

10. Connect the selector lever cable to the manual control lever. (Figure 12)

Figure 12

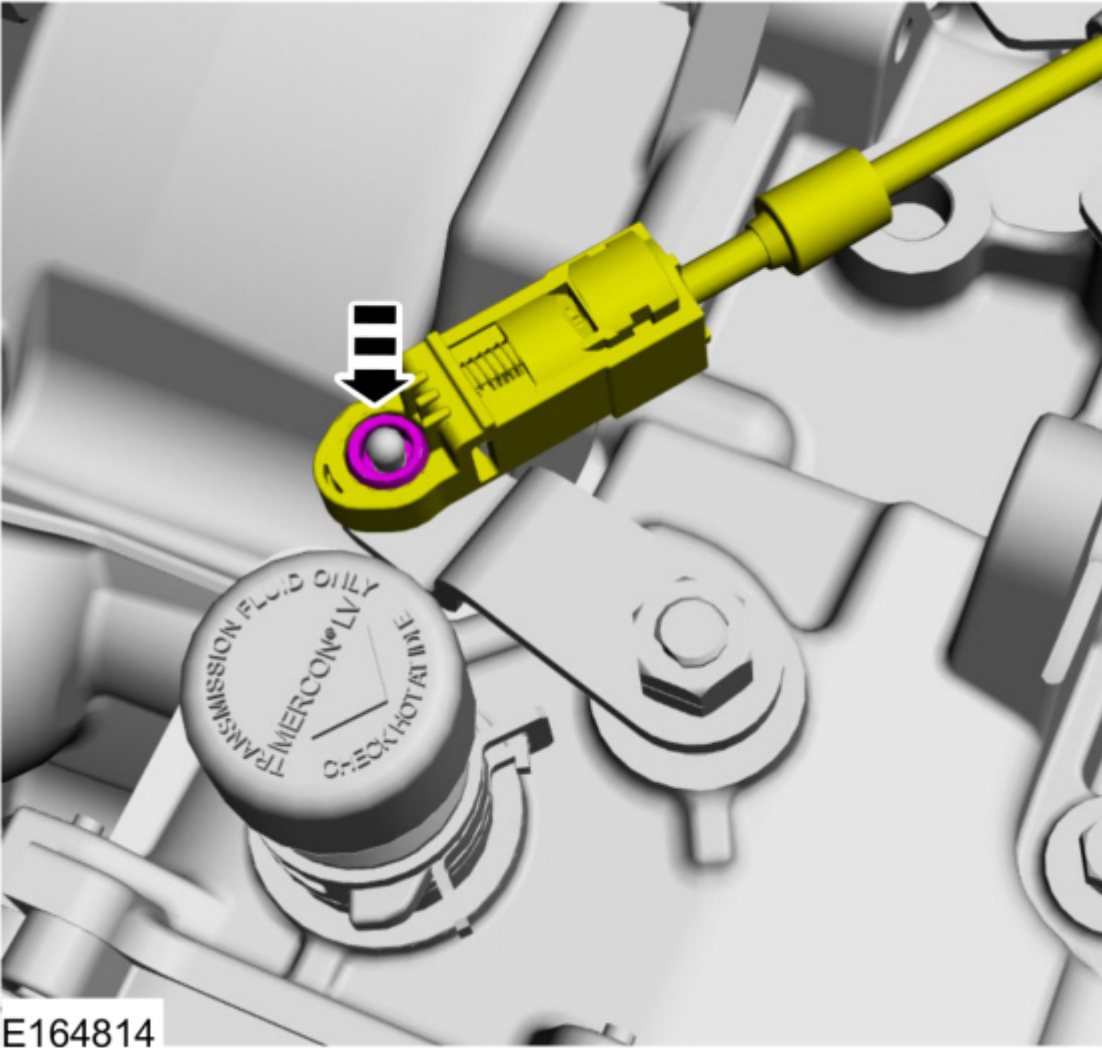

11. Slide the adjuster tab in place to lock the selector lever cable. (Figure 13)

Figure 13

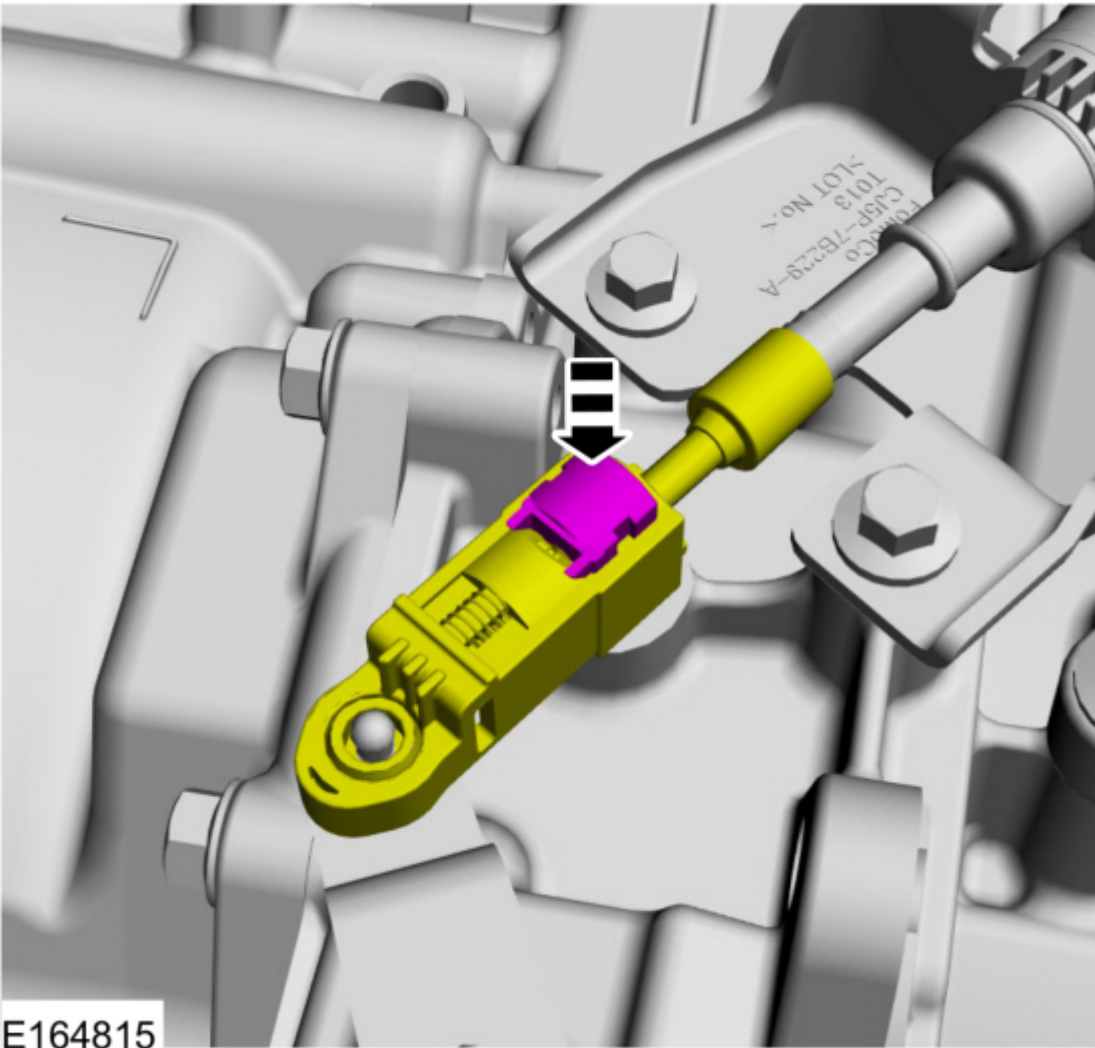

E164815

12. Visually inspect the cable end and give a slight pull up to verify the bushing is fully seated. If not fully seated, reseal the cable.
13. Install the new cap onto the selector lever cable adjuster. Clip one side into the adjuster body and then slide the other onto the housing until it snaps into place. The protective cap should cover the bushing and the terminal end of the adjuster. (Figure 14)

Figure 14



14. Verify the installation by checking the cap is retained by pulling on the adjuster body.
15. To assemble the vehicle, reverse the removal procedure. Refer to WSM, Section 307-05.

**16. Verify that the engine starts in PARK and NEUTRAL only and that the reverse lamps illuminate in REVERSE.**

---

© 2021 Ford Motor Company

All rights reserved.

NOTE: The information in Technical Service Bulletins is intended for use by trained, professional technicians with the knowledge, tools, and equipment to do the job properly and safely. It informs these technicians of conditions that may occur on some vehicles, or provides information that could assist in proper vehicle service. The procedures should not be performed by "do-it-yourselfers". Do not assume that a condition described affects your car or truck. Contact a Ford or Lincoln dealership to determine whether the Bulletin applies to your vehicle. Warranty Policy and Extended Service Plan documentation determine Warranty and/or Extended Service Plan coverage unless stated otherwise in the TSB article. The information in this Technical Service Bulletin (TSB) was current at the time of printing. Ford Motor Company reserves the right to supersede this information with updates. The most recent information is available through Ford Motor Company's on-line technical resources.