

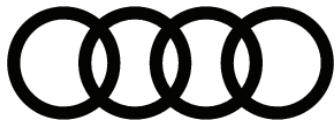

Audi e-tron GT (type F8)

Self-study programme SSP 684



For internal use only

Audi Service Training

Contents

Introduction

Introduction	4
Dimensions	5

Body

Introduction	7
Underbody structure	9
Body assembly	10

Power units

Electric drive motor for front axle	19
Electric drive motor for rear axle	20
Introduction	22
Construction of electric drive motors	22
Electric drive cooling system	26
Description of function	27
Electric drive control unit (power electronics)	27
Networking/sensors	30
Driving dynamics	32
Electronic engine sound	32

Power transmission

Overview	34
Selector mechanism	36
Single-speed transmission - OMG	39
Two-speed transmission OME	44
Service	80

Running gear

Overview	82
Axles	82
Wheel alignment	90
Adaptive air suspension	92
Electronic damping control	102
Steering system	104
Brake system	108
ESC 9.2	113
Electromechanical parking brake (EPB)	115
Integration of hydraulic brake system in vehicle's recuperation system	118
Wheels and tires, tire pressure monitoring	120

Electrics and electronics

12 Volt power supply	123
Networking	130
Control units	140
Terminal control	142
Exterior lighting	146

Convenience electronics

Control unit for head-up display J898	154
Convenience system central control unit J393	155
Front seats	155
Control unit in dash panel insert J285	158
Interior lighting	158
Central locking system with convenience key	160

High-voltage system

Safety regulations	161
Warning labels	162
Overview of high-voltage components	164
High-voltage battery AX2	165
Power contactor with boost function J1178	170

Voltage converter A48	172
Charging unit 1 for high-voltage battery AX4	173
Intermediate capacitors	175
Power contactors	175
Safety circuit	176
Charging	179

Air conditioning and thermal management

Climate control	187
Thermal management control unit J1024	190
Electrical air conditioner compressor V470	191
High-voltage heater (linear) Z189	192
Refrigerant circuit	193
Heat pump function	196
Heating circuit	198
Coolant circuit for high-voltage battery	200
Coolant circuit for electric powertrain	204
Cooling high-voltage battery 1 AX2 when charging	206

Safety and driver assist systems

Offer structure for driver assist systems	208
Special characteristics of the driver assist systems on the Audi e-tron GT	209
Fitting locations of sensors and control units	211
Maneuver assist	217
Park assist plus	220
Remote park assist plus	227
Passive safety	234
Airbag control unit J234	238
Sensors	240
Active safety	240

Infotainment and Audi connect

Introduction and overview of versions	242
Sound	243
Antennas	246

Servicing, inspection & roadside/breakdown assistance

Service interval display	250
Roadside/breakdown assistance	250

This self-study programme provides basic information on the design and function of new vehicle models, new components or new technologies.

It is not a Workshop Manual. Any figures given here are for explanatory purposes only and refer to the data valid at the time of writing.

Content is not updated.

It is essential that you refer to the latest technical literature when carrying out maintenance and repair work.

In the glossary at the end of this self-study programme you will find an explanation of all terms which are shown in *italics* and indicated by an arrow ↗.



Note



Reference

Introduction

Introduction



684_065

The Audi e-tron GT is a fully electric, driver-oriented, high performance Gran Turismo. With its expressive design, it has the potential to become a real classic, marrying performance driving with day-to-day practicality.

Initially, a sporty RS model and an all-rounder suitable for long journeys are available. What they have in common is their ability to reproduce the electrical motor performance for sporty acceleration at any time. The top model is the first fully electric RS with 440 kW and 830 Nm of system torque.

The e-tron GT puts Vorsprung durch Technik onto the road. 100 % electric quattro drive, torque vectoring and four-wheel steering provide new types of dynamic driving and excellent grip for the best handling and safety. High-power charging with up to 270 kW at 800 Volts enables short charging stops. Intelligent thermal management ensures permanently high charging performance during the entire charging process.

The e-tron GT is first Audi BEV with flat-floor architecture. The result is a low centre of gravity for a sporty look and dynamic handling. When designing the car, the designers put everything they learned in the wind tunnel into practice. The sophisticated active aerodynamics with controllable air inlets on the front don't just look effective: they are the basis for more range at higher speeds, along with excellent aerodynamic acoustics for a comfortable drive.

Product highlights

Aerodynamics

The vehicle is equipped with aerodynamic features such as controllable cool air intakes, air curtains, aerodynamic wheels, full trim on the underbody, targeted airflow around the brakes and tires along with a variable rear spoiler to control the air resistance and downforce at the rear according to the situation. These help to achieve a good drag coefficient and play a major part in providing good electrical range and driving performance.

Drive and high-voltage system

The permanently excited synchronous motors ensure powerful quattro drive, and the 800 Volt electrical system allows DC charging with up to 270 kW so that the vehicle can be charged for approx. 100 km of range in about five minutes.

Running gear and power transmission

With the optional three-chamber air suspension, the two-speed rear transmission unit and torque vectoring on the rear axle, the e-tron GT is the arbiter in the conflict between comfortable and sporty driving.

Driver assist systems

Alongside the tour, city and parking assist packages familiar from previous models, the park assist plus and the remote park assist plus are being offered for the first time.

Infotainment and Audi connect

With the e-tron route planner and the optional Bang & Olufsen 3D Sound System with 16 loudspeakers and 3D sound, the MIB 3 infotainment system provides top levels of acoustic comfort. And with the electronic engine sound for inside and outside, which can be adjusted by the driver in Audi drive select, Audi is bringing another acoustic dimension to electric sound.

Dimensions

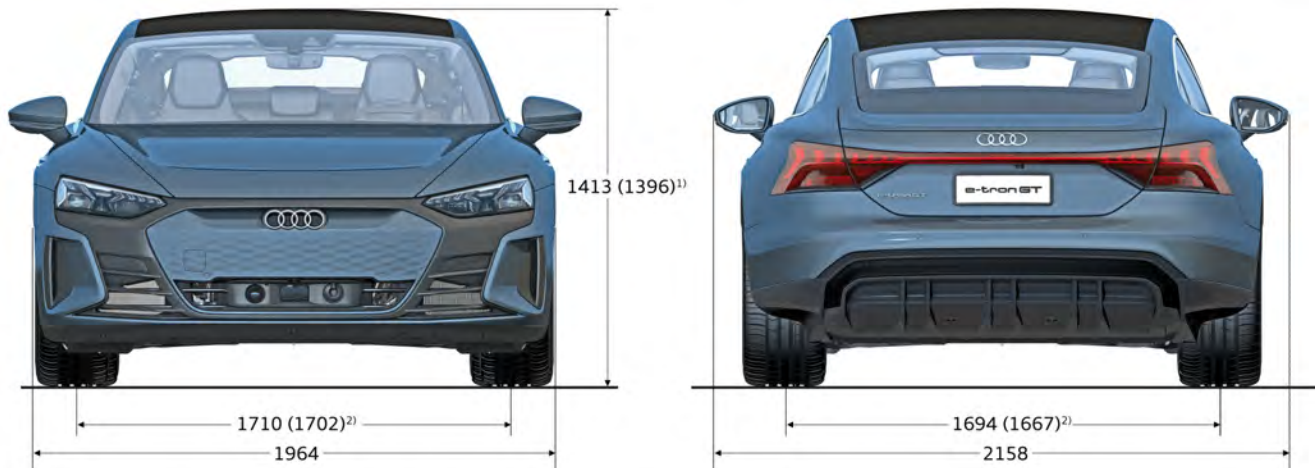

684_066

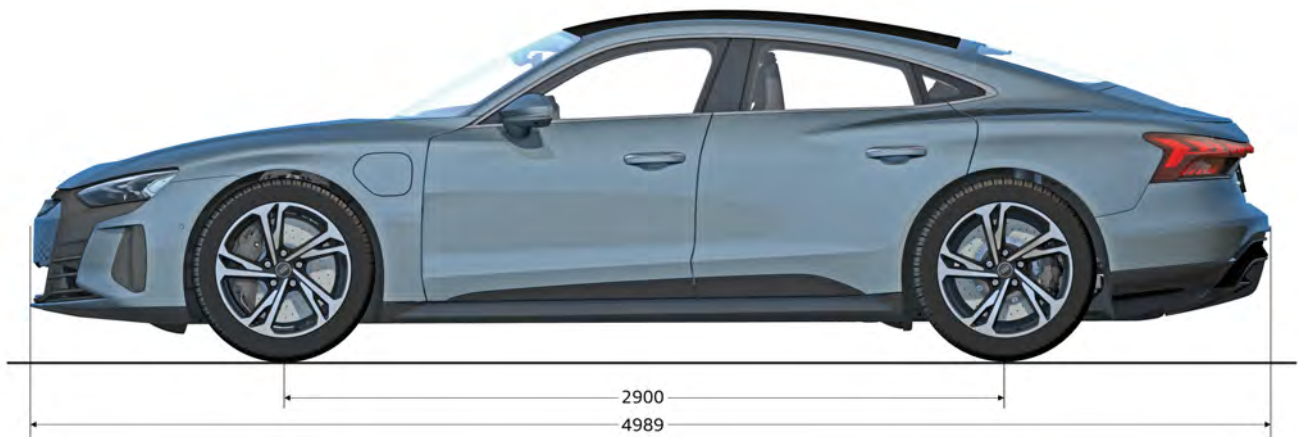

684_067

Exterior dimensions, weights, other data

Length in mm	4989
Width (not incl. mirrors) in mm	1964
Width (incl. mirrors) in mm	2158
Height in mm	1413 (1396) ^[1]
Wheelbase in mm	2900
Front track in mm	1710 (1702) ^[2]
Rear track in mm	1694 (1667) ^[2]
Turning circle in m	11.6
Unladen weight (EU) in kg	2351 (2422) ^[2]

[1] Value in brackets is with air spring

[2] Value in brackets applies to RS model

Max. gross weight in kg	2840 (2860) ^[2]
Peak electric power output in kW	350 (440) ^[2]
Electric torque in Nm	630 (830) ^[2]
Drag coefficient	0.24
Load sill height in mm	697 (681) ^[1]
Front luggage compartment capacity in ltr.	81
Rear luggage compartment capacity in ltr.	405 (350) ^[3]

[2] Value in brackets applies to RS model

[1] Value in brackets is with air spring

[3] Value in brackets applies to equipment version with Bang & Olufsen Premium Sound System

Body

Introduction

The body of the Audi e-tron GT (type F8) is a modern composite construction which uses various materials. The quality of the materials selected not only reduces weight, but also provides the basis for meeting the stringent vehicle safety standards. The majority of components used in the body structure are made of cold-formed or hot-formed steel panels, aluminum extrusions or aluminum castings. Aluminum panels are used for the outer skin.

Outer skin

- > Front Fenders
- > Doors
- > Hood
- > Rear lid
- > Side panels

These components are made of aluminum on the Audi e-tron GT (type F8).

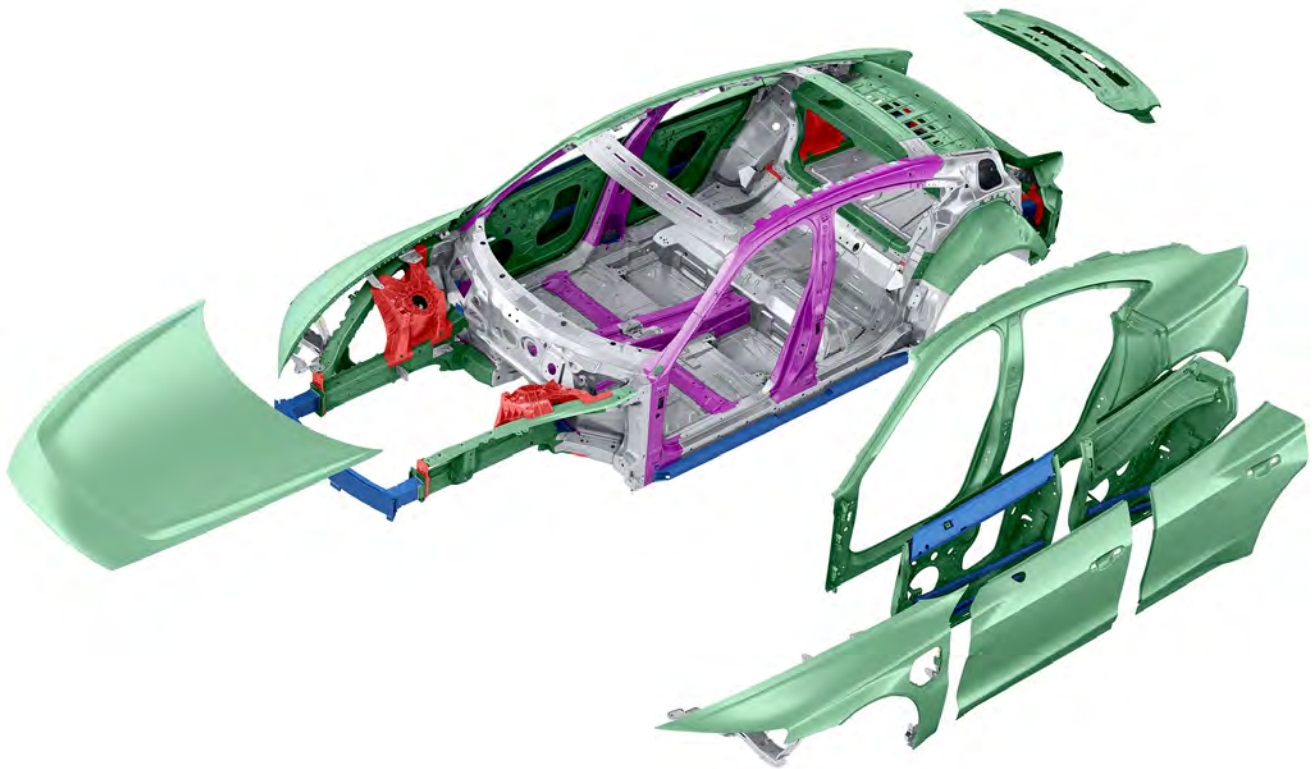



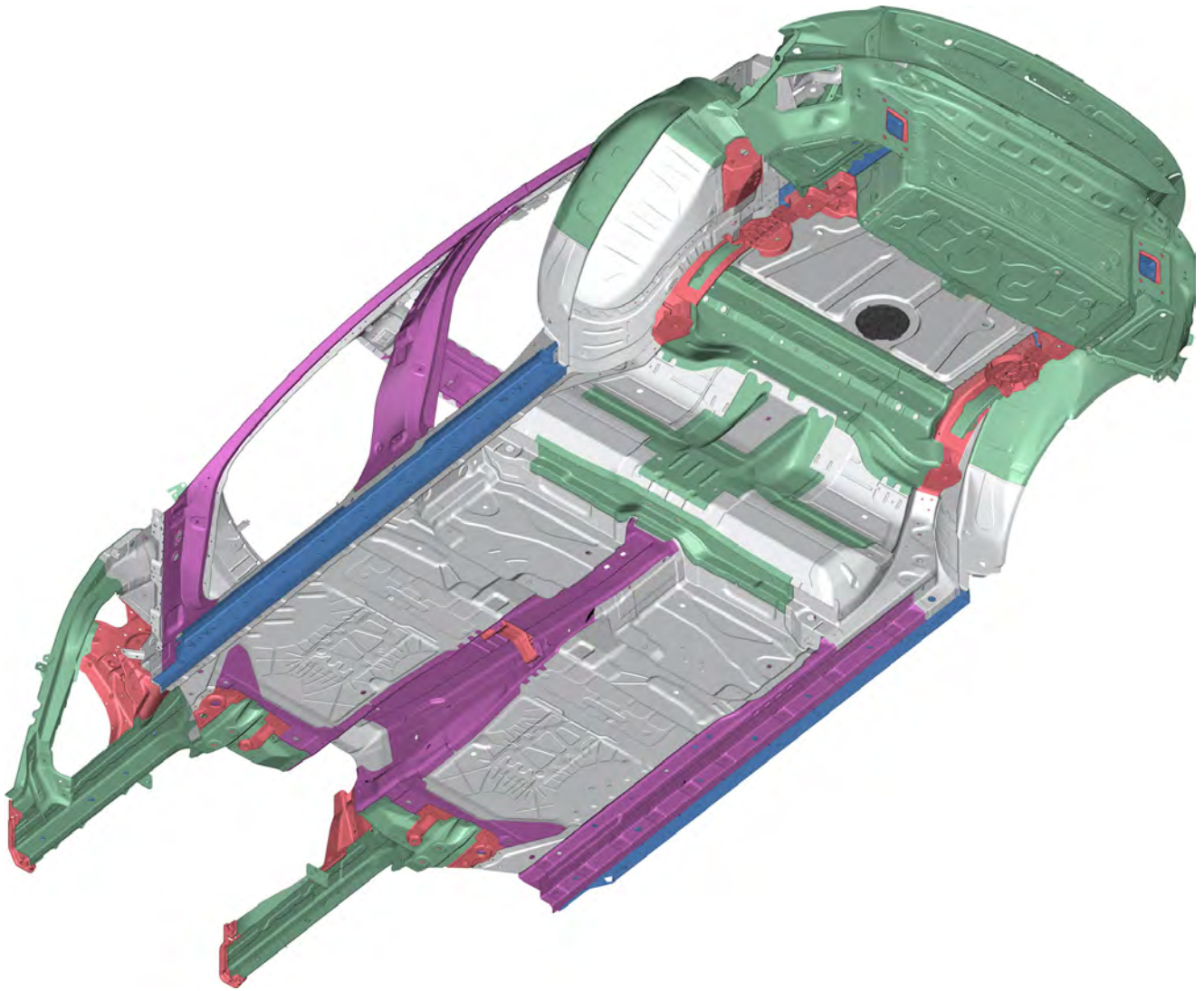

684_098



684_137

Key:

-  Cold-formed steel
-  Hot-formed steel
-  Die-cast aluminum
-  extrusion aluminum
-  panel

Joining techniques

The following joining techniques are used in the manufacture of the multi-material body:

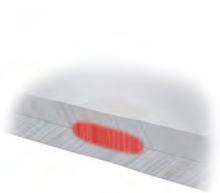

Resistance spot welding for steel



MIG/MAG welding



Laser welding for aluminum

The following joining techniques are used in the manufacture of the multi-material body:

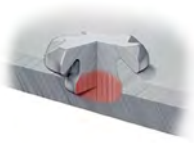

Friction element welding



Semi-tubular punch riveting



Bonding



Flow-drill screws



Seaming

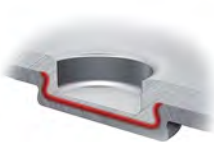

Clinching

Underbody structure

The high-voltage battery has been fully integrated into the supporting body structure in the vehicle floor on the Audi e-tron GT (type F8) using a battery frame. The battery frame increases the rigidity of the body, particularly in areas that are especially relevant for safety (such as the high-voltage battery).

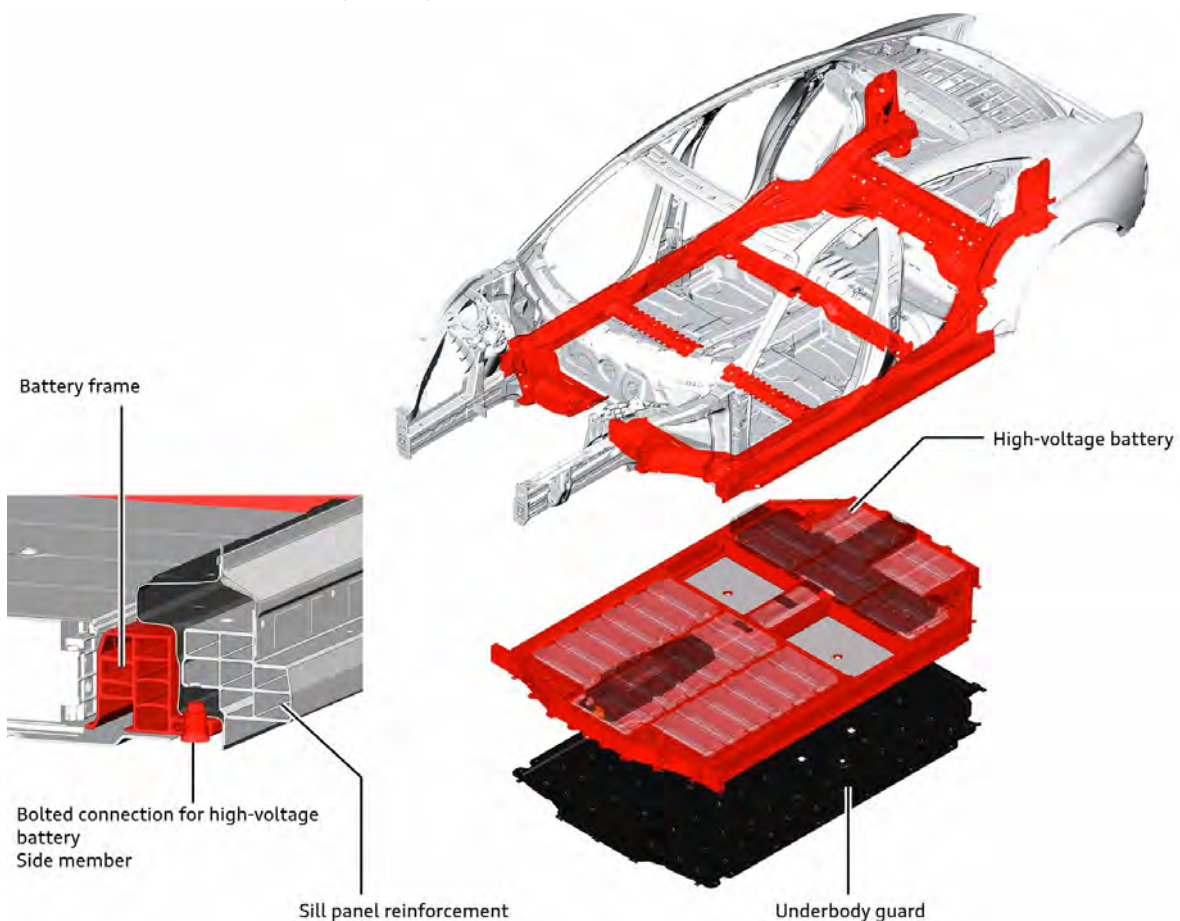

684_139

High-voltage battery

The high-voltage battery is secured to the underbody of the Audi e-tron GT with a total of 28 bolts.

Battery frame

The battery frame made of aluminum extrusions not only provides the highest possible protection in the event of an accident but also increases the body's torsional rigidity. If the battery frame is damaged, it must be replaced.

Underbody guard

The underbody guard is made of aluminum and is bolted and bonded onto the battery frame. It protects the high-voltage battery against damage from below (e.g. from stones) and can be replaced separately if damaged. If the battery frame (aluminum extrusion) is damaged, it must be replaced.

Sill panel reinforcement

The sill panel reinforcement increases the rigidity of the body in a side impact, particularly in areas that are especially relevant for safety (such as the high-voltage battery).

Body assembly

Aerodynamics

Particularly on electric vehicles, the aerodynamics are a key factor for the range. Especially at high speeds, small details have a positive effect on air resistance and therefore also on the performance and efficiency of the vehicle.

Air curtains

Controlled airflow at the front wheels plays a major role in the aerodynamic concept. The side air inlets at the front of the vehicle (the air curtains) guide the air into the wheel housings via a channel so that the wheels and the side of the vehicle have optimal airflow. Narrow horizontal ribs in the air ducts guide the air so that disruptive swirls in the wheel housings are encapsulated. This results in the air travelling more "cleanly" along the side of the vehicle with reduced flow losses. The design of the aerodynamic wheels along with the profile and the embossing of the tire sidewalls are also optimised in this regard.

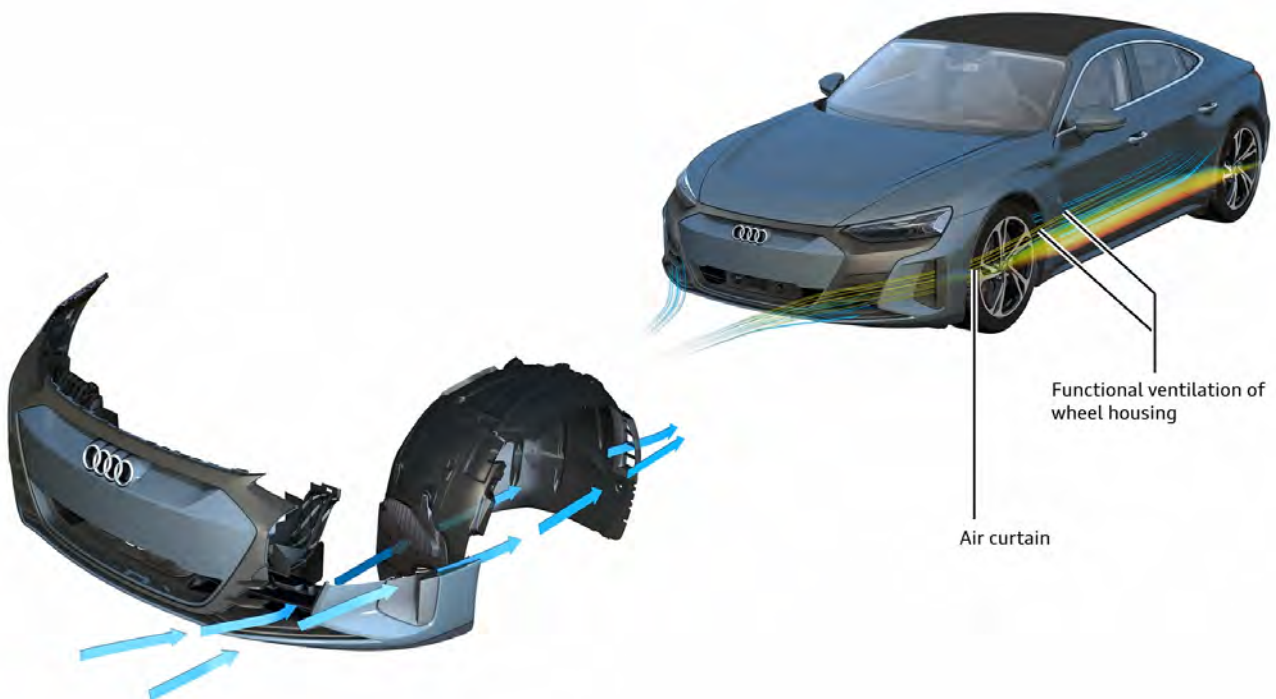

684_302

Underbody

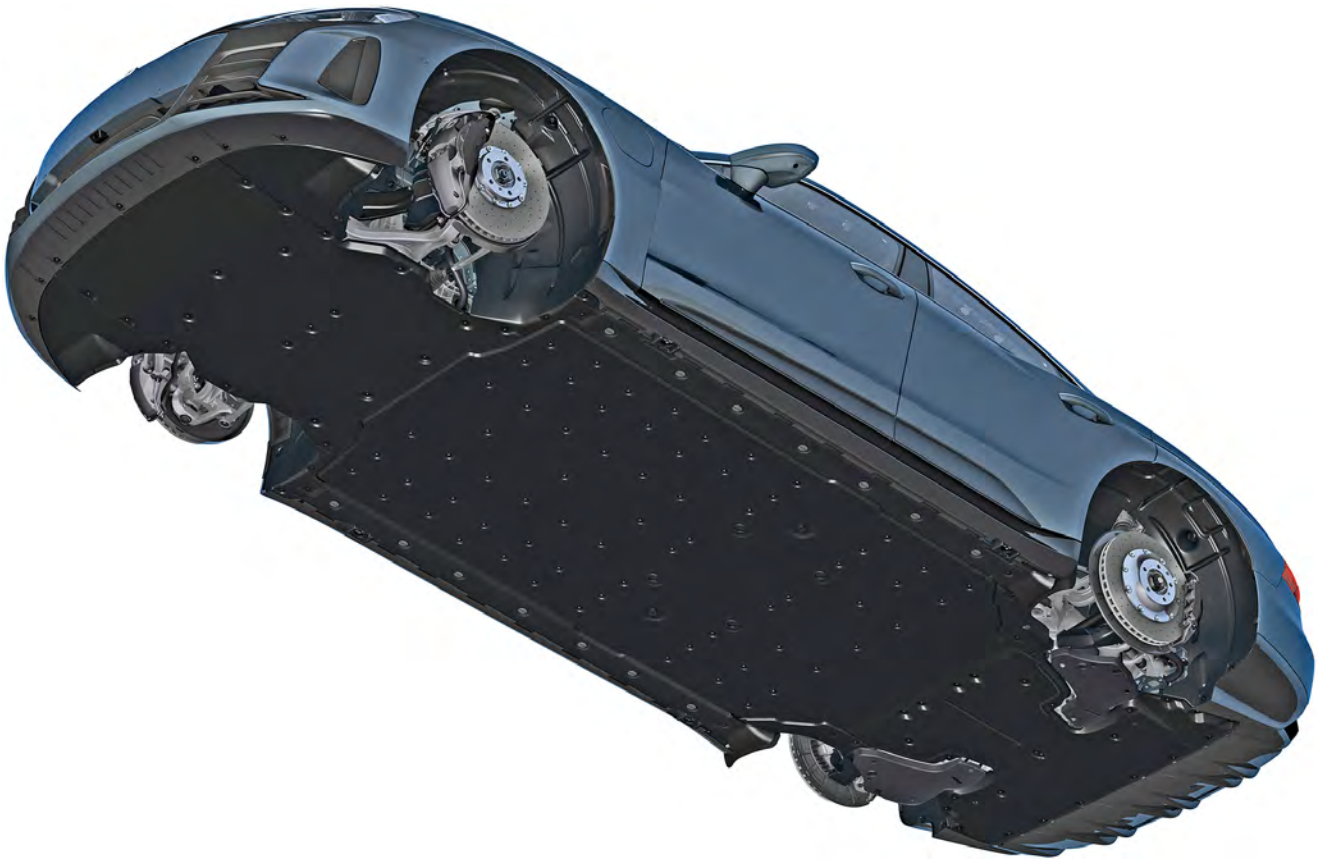

684_315

The complex aerodynamic concept continues under the vehicle floor, where underbody trim with spoiler elements guides the air cleanly around the vehicle. Trim is fitted to the entirety of the underbody (including the aluminum cover plate for the high-voltage battery). The screw connections take the form of bowl-like indentations, similar to the dimples on a golf ball. They allow the air to flow even more easily than a fully flat surface would.

Rear spoiler

The Audi e-tron GT (type F8) has a retractable spoiler in the rear lid. Depending on the speed, the spoiler blade is automatically moved into two positions. A button on the MMI touch display can also be used to move the spoiler to its upper end position manually. If the button is pressed for longer, the spoiler is moved back into the position corresponding to the current speed. If the spoiler is manually moved to its end position, it stays there if the vehicle is stopped or parked. After terminal 15 is switched on, the spoiler retracts automatically once the vehicle is travelling over 20 km/h.

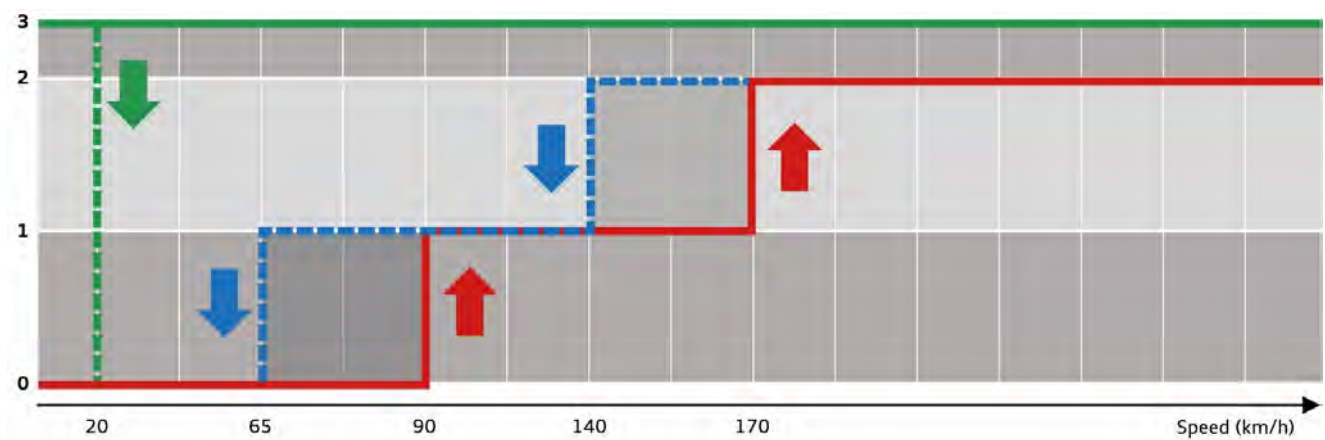

684_231

- 0 Spoiler retracted
- 1 Spoiler in ECO position

- 2 Spoiler in performance position
- 3 End position (manual)

It is actuated by rear spoiler adjustment control unit J223. The position of the spoiler is monitored by two Hall sensors in the spoiler adjustment system. One of the sensors measures the end position of the extended rear spoiler, while the other counts the number of drive motor revolutions while the spoiler is being retracted.

Adjusters allow the height of the spoiler blade to be aligned vertically (z axis) in relation to the rear lid and side panel. Elongated holes are used for alignment in the longitudinal and transverse directions (x and y axes).

Drain hoses on the right and left ensure that rainwater can be channelled out of the drive unit for rear spoiler adjustment. Since moulded hoses are used, the markings on both sides must align with each other when the hoses are fitted onto the mountings.

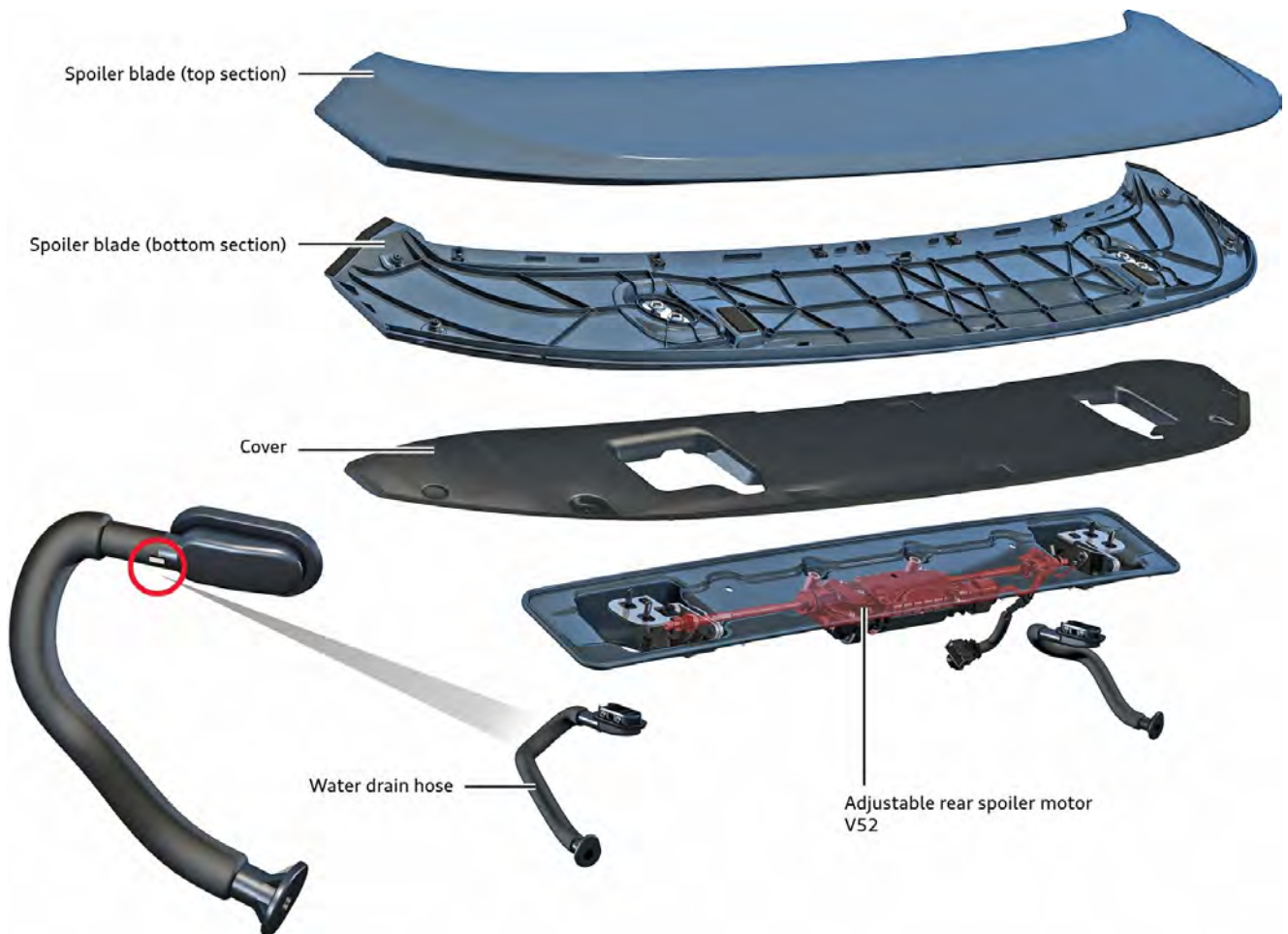

684_308

Glass trim

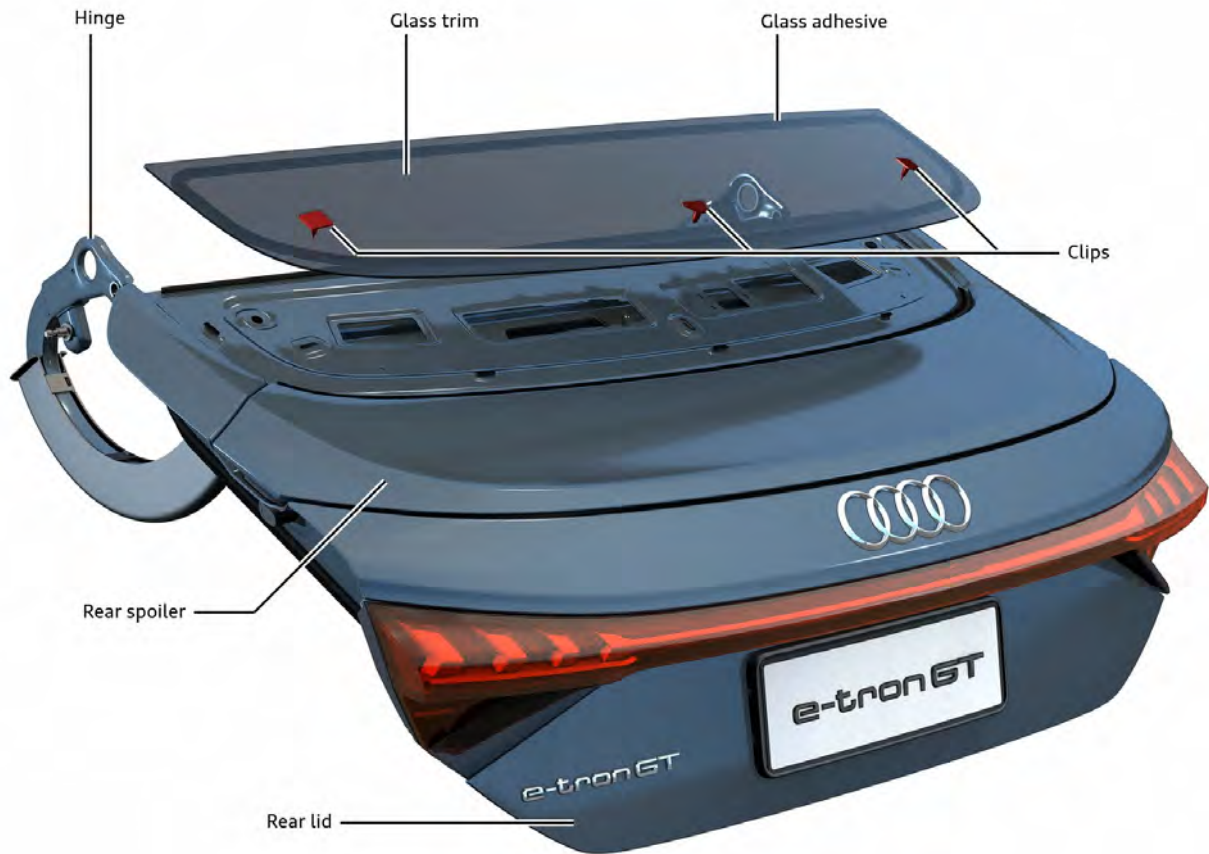

684_307

The rear window is optically lengthened downwards with a piece of glass trim made of tinted safety glass fitted above the spoiler. Three clips ensure that the trim is positioned correctly. It is bonded to the rear lid with window adhesive.

Rear lid



684_304

The electrically operated rear lid in the Audi e-tron GT (type F8) is operated via a spindle drive on the rear lid hinge (left-side).



Note

When motor for rear lid V444 is removed, the electrical connector must be unplugged first. The clip on the ball mounting must then be pressed together with 90° angled long-nose pliers. Under no circumstances should the clip be prised off with a screwdriver or a similar tool.

Roof

Two roof versions are available for the Audi e-tron GT (type F8); the CFRP roof or the panoramic sunroof.

CFRP roof



684_313

The outer section of the roof (made of clear-coated CFRP) is bonded to a frame made of extra-high-strength steel. Acoustic fleece material at the front and rear provides the necessary noise insulation. The CFRP outer skin only weighs approx. 4.2 kg; the entire roof (including frame, adhesive, seals and acoustic fleece) weighs approx. 10.2 kg. The uppermost, visible carbon fibre weaving has a 0/90° orientation/a twill of 45°. This means that the parallel lines of the twill weave are diagonal to the vehicle's longitudinal axis.

No roof carrier system is available in conjunction with the CFRP roof.

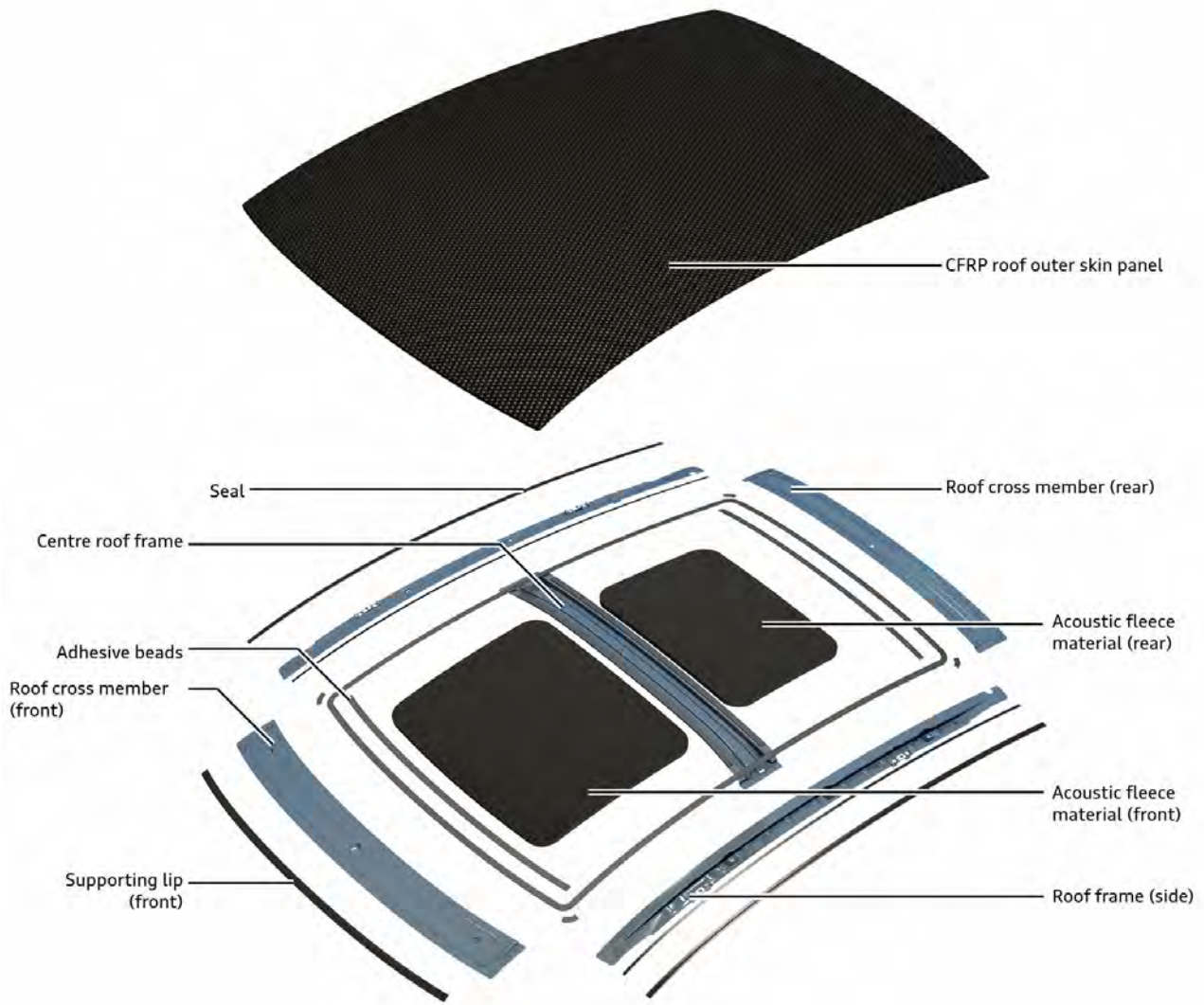

684_314

Panoramic sunroof

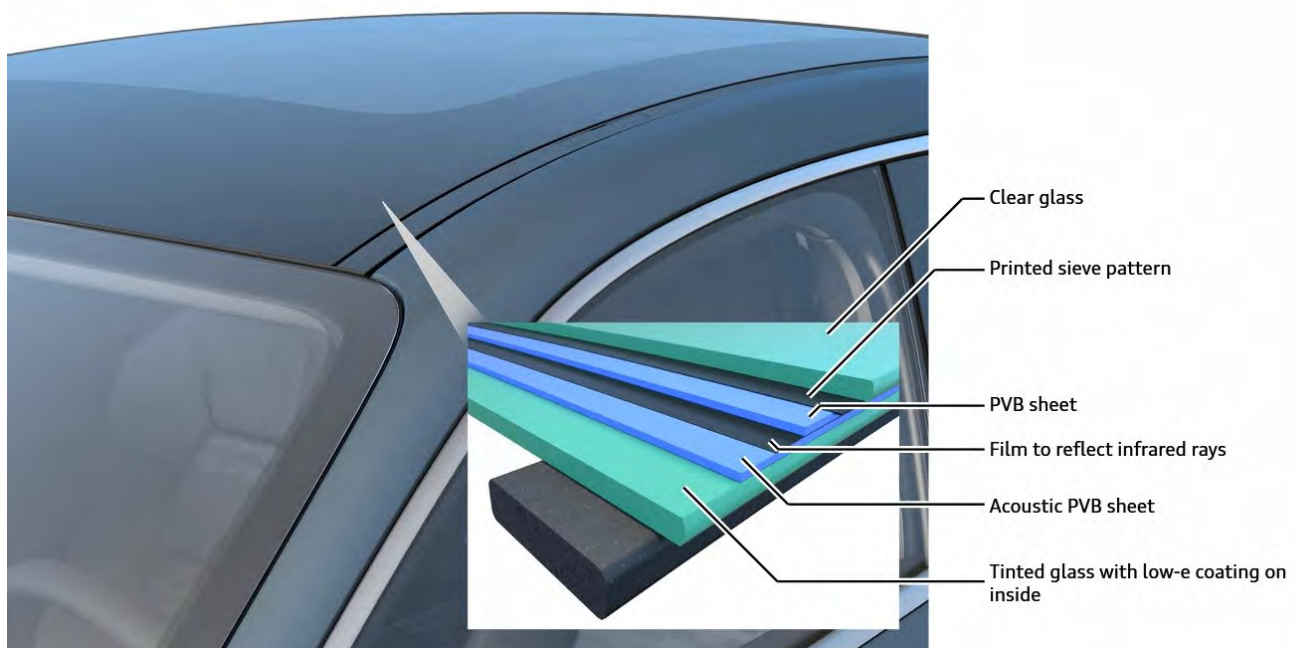

684_311

The panoramic sunroof covers the entire roof surface and is permanently bonded to the vehicle body. It cannot be opened. The laminated safety glass has an acoustic foil covering and an additional foil covering which almost entirely reflects infrared rays. An additional low emissivity coating provides additional heat and sun protection. Retainers for a roof carrier are integrated under the side roof trim strips. The entire panoramic sunroof (including frame, adhesive, seals and bracket) weighs approx. 22.5 kg.

Vehicle interior



Floor mats and carpets made of Econyl®

The "Cascade" seat cover is made of 35 % recycled PET bottles and 15 % recycled textile fibres.

Optional Dinamica

Seat padding made of 85 % recycled PET bottles

684_316

A major emphasis was placed on sustainability when selecting materials for the vehicle interior.

For example, the floor mat and the carpet are made of Econyl®.

Nylon waste which would otherwise pollute our planet (such as fishing nets, fabric remnants, carpets and industry waste) are collected, sorted and cleaned to win back the nylon contained therein. In an extensive cleaning and regeneration process, nylon fibres are created from the regenerated nylon waste and subsequently woven into, among other things, carpets for the Audi e-tron GT (type F8).

The foam of the seat padding is made of 85 % recycled PET bottles.

The Cascade seat cover is made of 35 % recycled PET bottles and 15 % regionally recycled textile fibres. This seat cover is fitted on the Audi e-tron GT (type F8) with leather-free interior (PR number: 7HF). In this case, the interior elements are partly covered with leatherette and partly with the high-end microfibre Dinamica. This fibre is also primarily made of recycled polyester fibres and is 100% recyclable. The Alcantara steering wheel is fitted on this version.

Dash panel

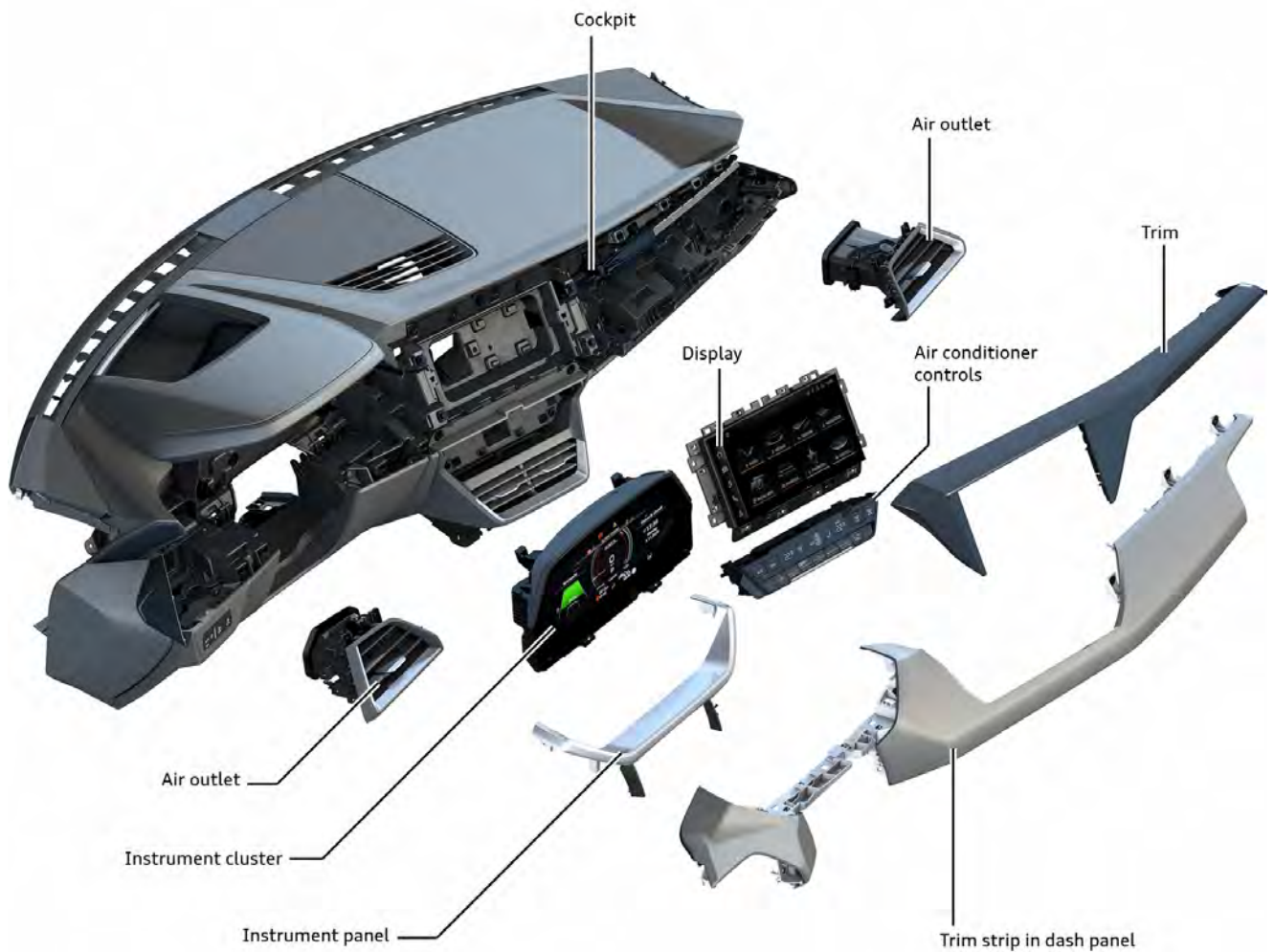

684_310

The cockpit of the Audi e-tron GT (type F8) is very driver-oriented. This is achieved, on the one hand, by setting the MMI touch display at an angle towards the driver. On the other hand, the lines of the door trim and the cockpit create a visual frame around driver's area. Also thanks to the mainly horizontal basic architecture, the interior of the vehicle gives a high-quality, progressive and tidy impression. The layered structure of the dash panel must be taken into account when dismantling and assembling. It may be necessary to remove more parts than initially expected to remove a component. Please therefore always follow the procedures described in the most recent service literature.

Power units

Electric drive motor for front axle

Motor with code EBGA



684_055a

Torque/power curve

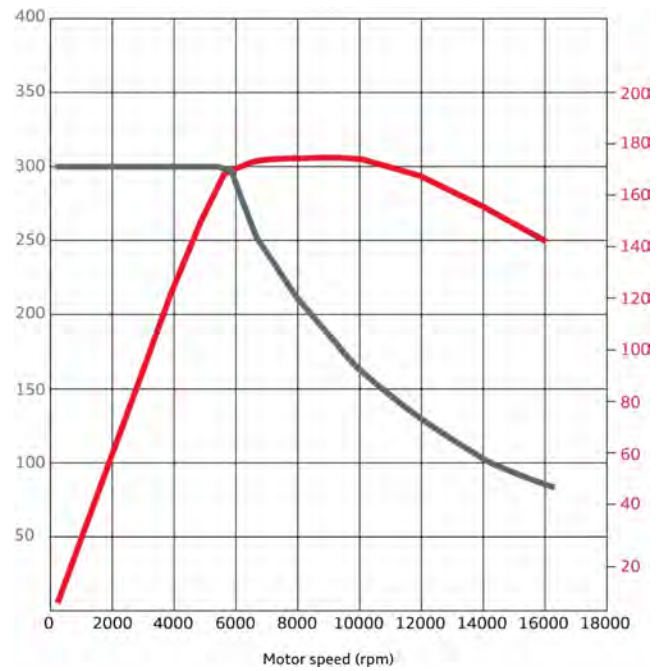

684_377

— Power in kW
— Torque in Nm

Characteristics	Technical data
Insert	e-tron GT and RS e-tron GT (front axle)
Engine code	EBGA
Body type	Permanently excited synchronous motor
Type of rotor	Internal rotor
Pole pairs	4
Cooling	Cooling jacket around stator windings
Coolant	G12 evo
Continuous power output in kW at 8000 rpm	80 kW
Peak power output at 8000 rpm	175 kW
Torque in Nm at up to 5500 rpm (4 sec)	300 Nm

Electric drive motor for rear axle

Motor with code EBFA



Torque/power curve

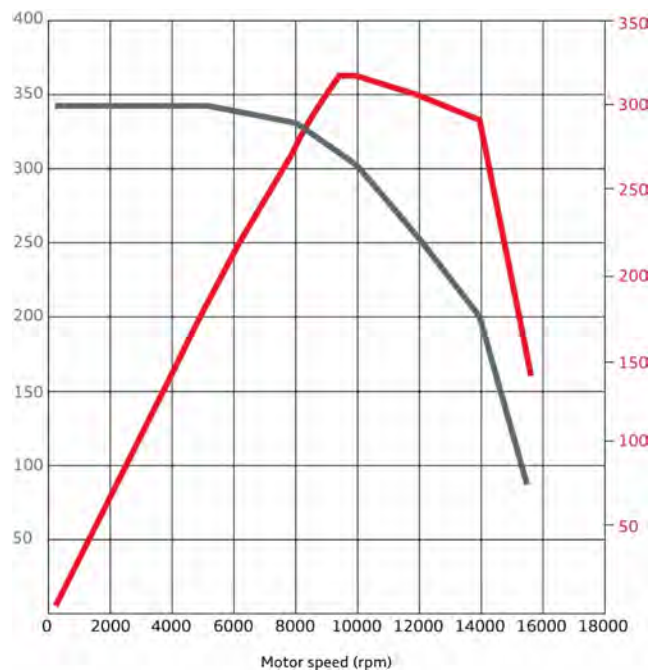

684_378

684_055b

— Power in kW
— Torque in Nm

Characteristics	Technical data
Application	e-tron GT (rear axle)
Motor code	EBFA
Body type	Permanently excited synchronous motor
Type of rotor	Internal rotor
Pole pairs	4
Cooling	Cooling jacket around stator windings
Coolant	G12 evo
Continuous power output in kW at 10000 rpm	120 kW
Peak power output at 10000 rpm	320 kW
Torque in Nm at up to 5000 rpm (4 sec)	340 Nm

Motor with code EBEA



Torque/power curve

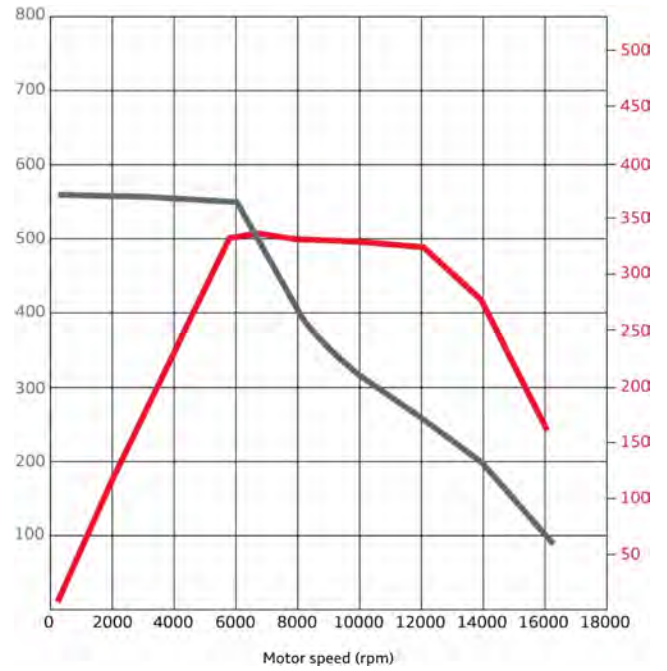

684_391

684_055b

— Power in kW
— Torque in Nm

Characteristics	Technical data
Application	RS e-tron GT (rear axle)
Motor code	EBEA
Body type	Permanently excited synchronous motor
Type of rotor	Internal rotor
Pole pairs	4
Cooling	Cooling jacket around stator windings
Coolant	G12 evo
Continuous power output in kW at 8000 rpm	170 kW
Peak power output at 6700 rpm	335 kW
Torque in Nm at up to 5900 rpm (4 sec)	550 Nm

Introduction

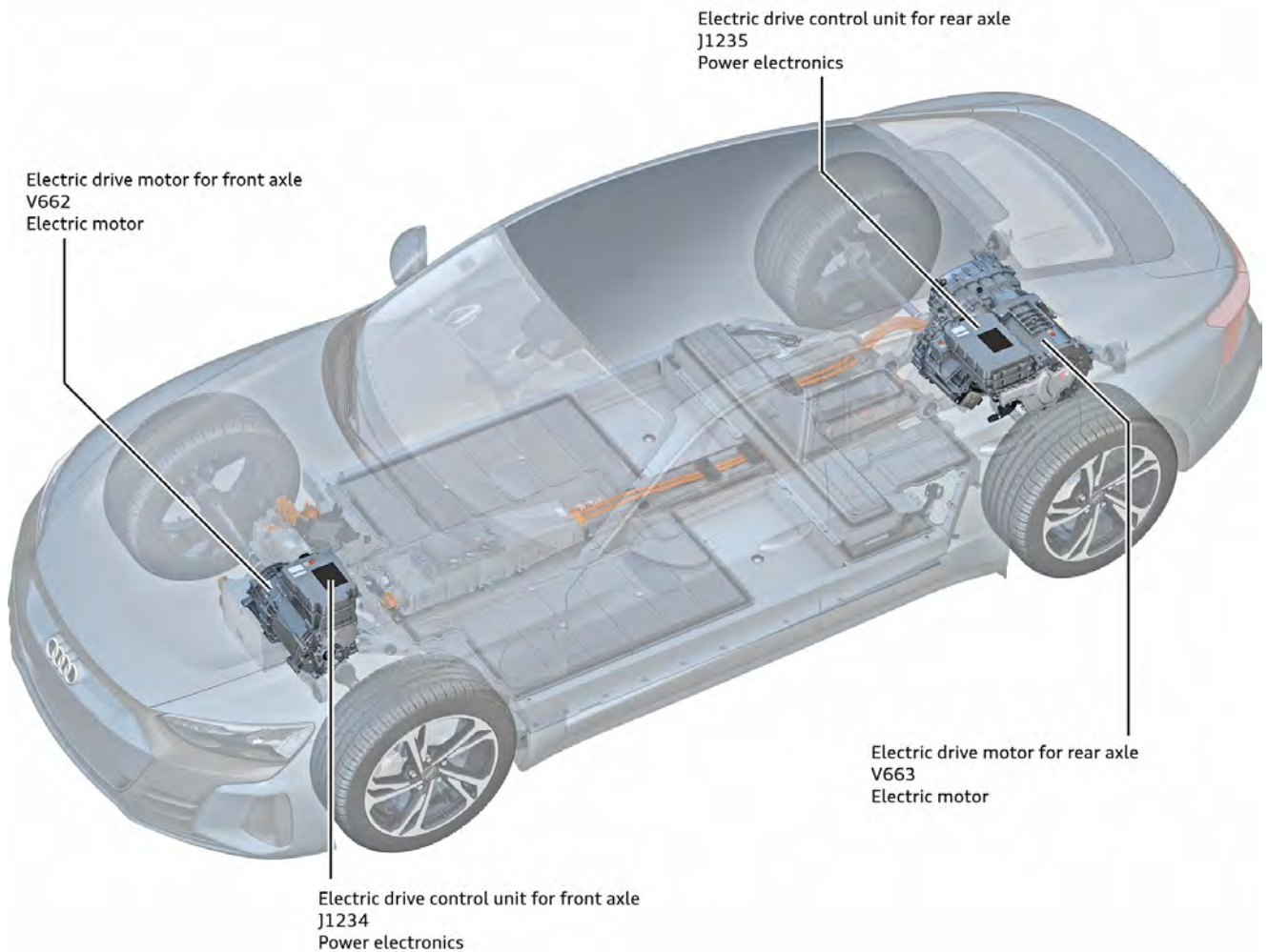

684_219

Permanently excited synchronous motors are fitted on front and rear axles of the e-tron GT and RS e-tron GT (type F8). The high power density of the motors allows for a very dynamic motor response. The construction of the electric drive motors differs in the active length of the rotor/stator core. The design of the power electronics is also different on the front and rear axles. The power electronics on the front axle can process a maximum current of 300 amperes. The power electronics on the rear axle can manage 600 amperes.

Construction of electric drive motors

General information

The electric drive motors on the Audi e-tron GT (type F8) are permanently excited synchronous motors. On the rear axle, this is a construction parallel to the axle, and on the front axle it is coaxial. Different power outputs from the electric drive motors are achieved by different rotor/stator core lengths. The larger the rotor/stator core is, the larger the magnetic field will be. This is referred to as the length of the active components.

Active length of front axle	160 mm
Diameter of axle	190 mm
Active length of rear axle (e-tron GT)	130 mm
Diameter of rear axle (e-tron GT)	245 mm
Active length of rear axle (RS e-tron GT)	210 mm
Diameter of rear axle (RS e-tron GT)	245 mm

Drive motor on rear axle (e-tron GT)

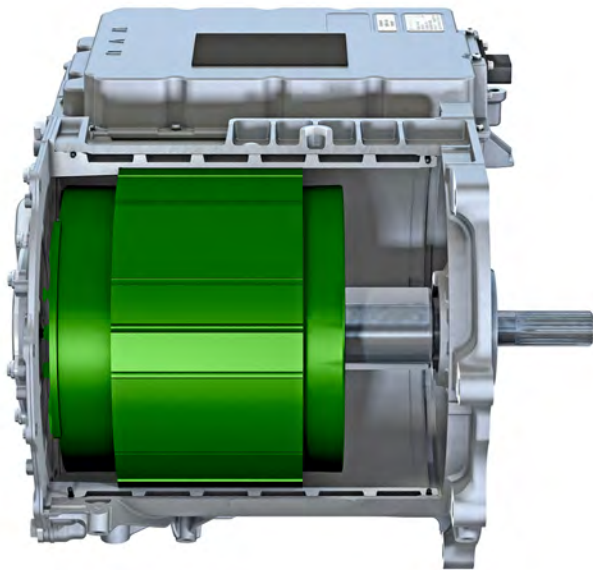

684_375

Drive motor on rear axle (RS e-tron GT)

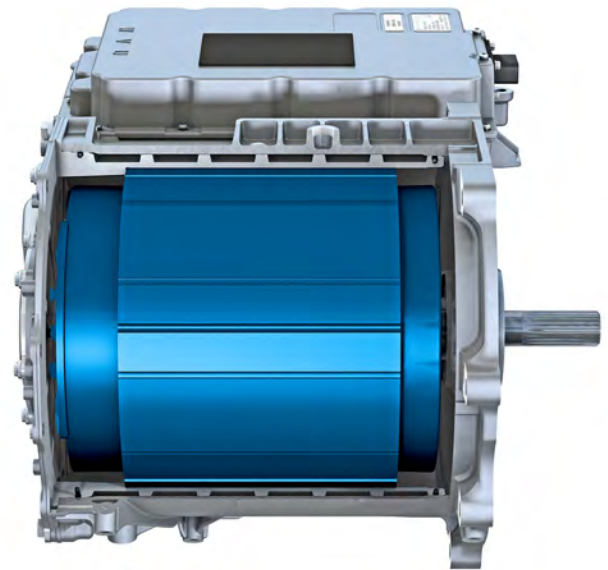

684_376

Front axle

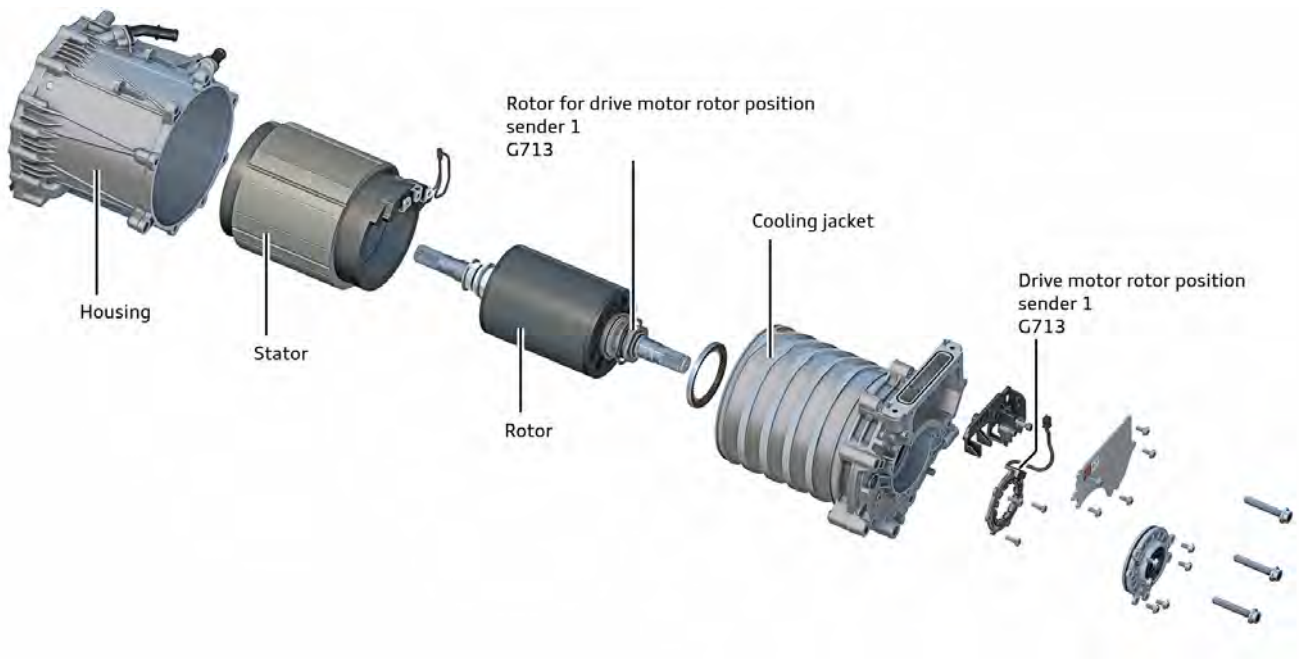

684_252

Rear axle

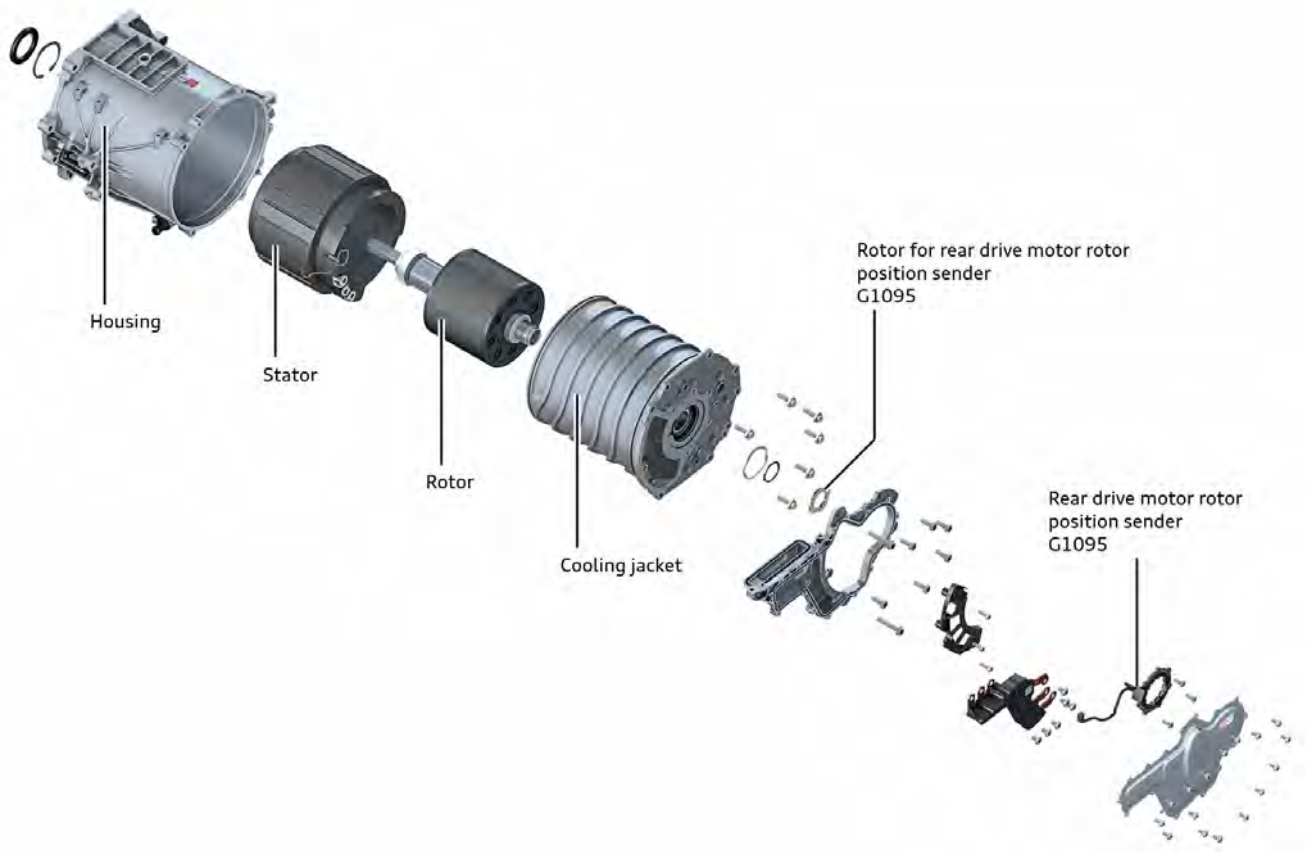

684_379

Rotor

The rotor is made up of permanent magnets arranged with alternating poles. The magnets used are very strong ferrite magnets that are magnetised artificially during manufacturing. The air gap between the rotor and the stator is kept very small, increasing the efficiency of the motor.



684_429

Stator

The stator is made of thin metal plates that are insulated from one another. The plates strengthen the magnetic field produced by the current flowing through the copper windings. The copper windings are integrated in the metal plates and are known as hairpin windings. The advantage of this type of winding is that, compared to conventional windings, a higher amount of copper can be housed in the same amount of space. Heat dissipation characteristics are also improved by this type of winding.



684_430

Conventional winding

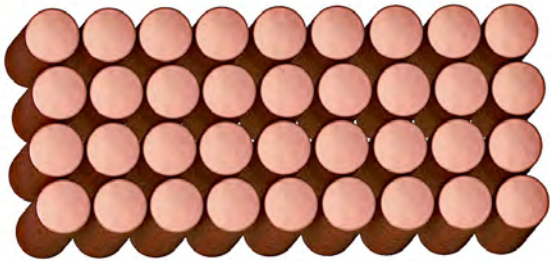

684_373

Hairpin winding

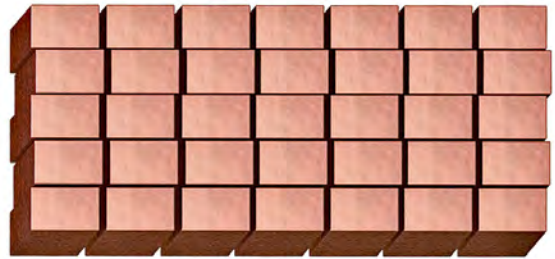

684_374

Drive motor rotor position sender 1 G713 / rear drive motor rotor position sender G1095

The rotor position senders work on the resolver principle. The senders consist of a rotor disc made of field-conducting material, field coils and receiver coils. All receiver coils have a different number of windings. Because the field coils are supplied with a sinusoidal voltage, a magnetic field is generated in the field coils. This magnetic field is induced in the receiver coils.

If one of the lobes of the rotor disc now intersects the magnetic field of a receiver coil, the magnetic field in the corresponding coil is strengthened.

Because of the different number of windings, the control unit can detect the position of the rotor precisely. The speed of the electric drive motors is determined based on the number of occurrences. The rotor position senders do not wear and are resistant to ageing.

Drive motor rotor position sender 1 G713 /
Rear drive motor rotor position sender G1095

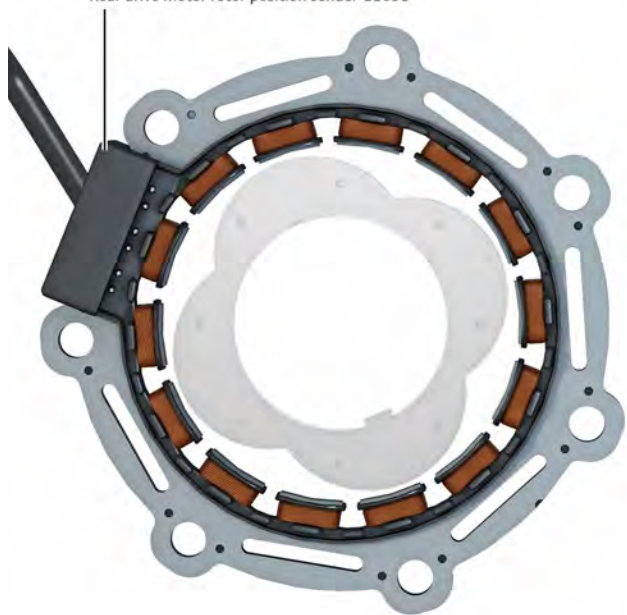

684_335

Electric drive cooling system

Coolant flows through the electric drive motors on the front and rear axles. They are integrated in the coolant circuit for the electric powertrain. The power electronics are also integrated into this coolant circuit. The coolant flowing in is first directed to the power electronics to dissipate the high levels of heat at the power modules. The coolant then flows through the stator cooling jacket. On the rear axle, the coolant is additionally routed through the 2-speed transmission unit, before it leaves the electric drive motor. On the Audi e-tron GT, only G12evo coolant must be used.

Front axle

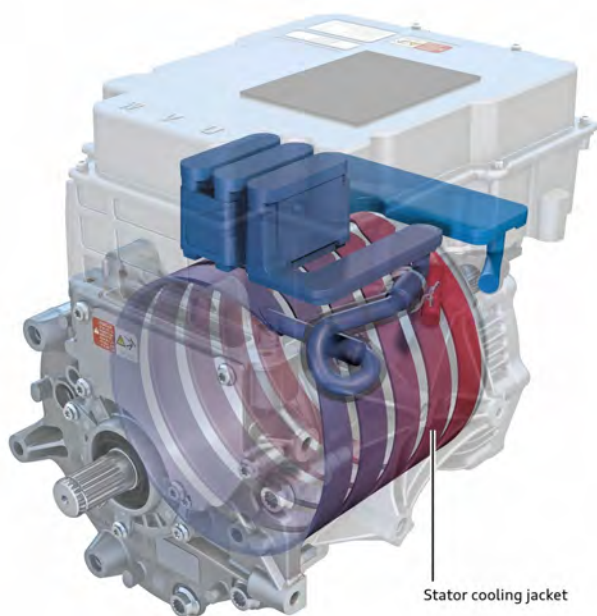

684_241

Rear axle

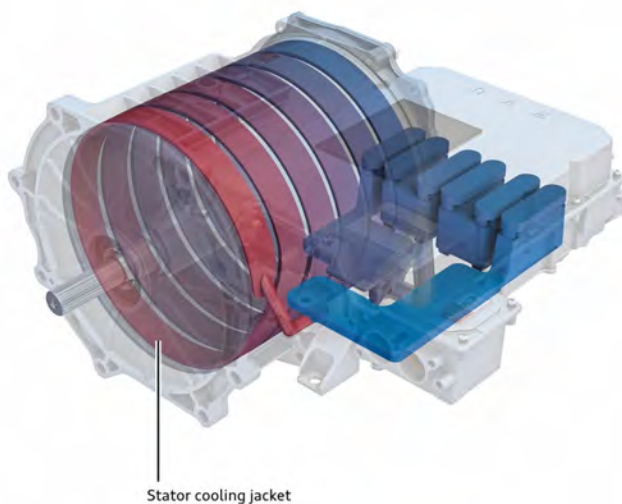

684_242

Description of function

The power electronics applies an alternating voltage displaced by 120° to the coils. This generates a magnetic field that alternates its direction continuously. This characteristic is also used to drive the rotary-mounted magnets. If the positive edge of the sine wave is applied to the coil, the north pole is attracted; when it is the negative edge, the south pole is attracted. The motor begins to turn. The faster the frequency of the power electronics, the quicker the motor turns. In recuperation, a voltage is induced in the stator coils by the magnetic field of the permanent magnets. This energy is used to charge the battery. As the electric drive motors on the Audi e-tron GT are permanently excited synchronous motors, the rotation of the field in the stator is just as fast as the speed of the rotor. The motors are fully regulated by the power electronics, which process the driver's requests.



Reference

Further information on this topic can be found in Service TV programme 0568 TV "Electric drives – Motors".

Electric drive control unit (power electronics)

Introduction

Power electronics have become an integral part of today's electrical engineering. They have the task of converting electric energy using electronic components – be it from alternating voltage to direct voltage or vice versa. To be able to switch high three-figure ampere currents, power electronics are being further developed on a daily basis. There are two different versions of the electric drive control unit on the Audi e-tron GT (type F8). Each of the power electronics is connected to the vehicle body via a potential equalisation line.

Electric drive control unit for front axle J1234 (300 A version)

Electric drive control unit for front axle J1234 is bolted onto the electric drive motor. The contact between the control electronics and the electric drive motor is fixed.

Contacts on front axle

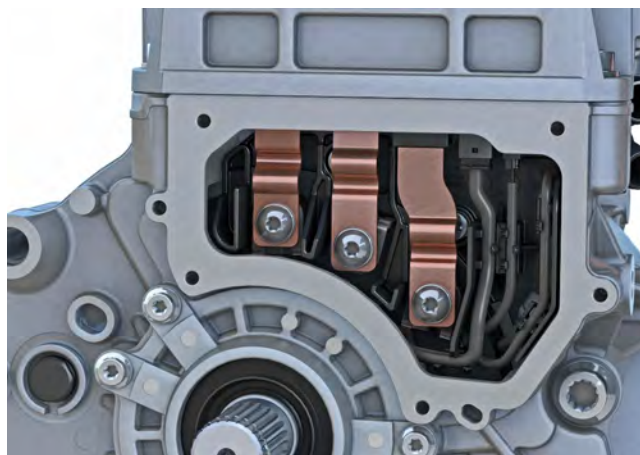

684_362



Note

Electric drive control unit for front axle J1234 must under no circumstances be opened.

How the system works

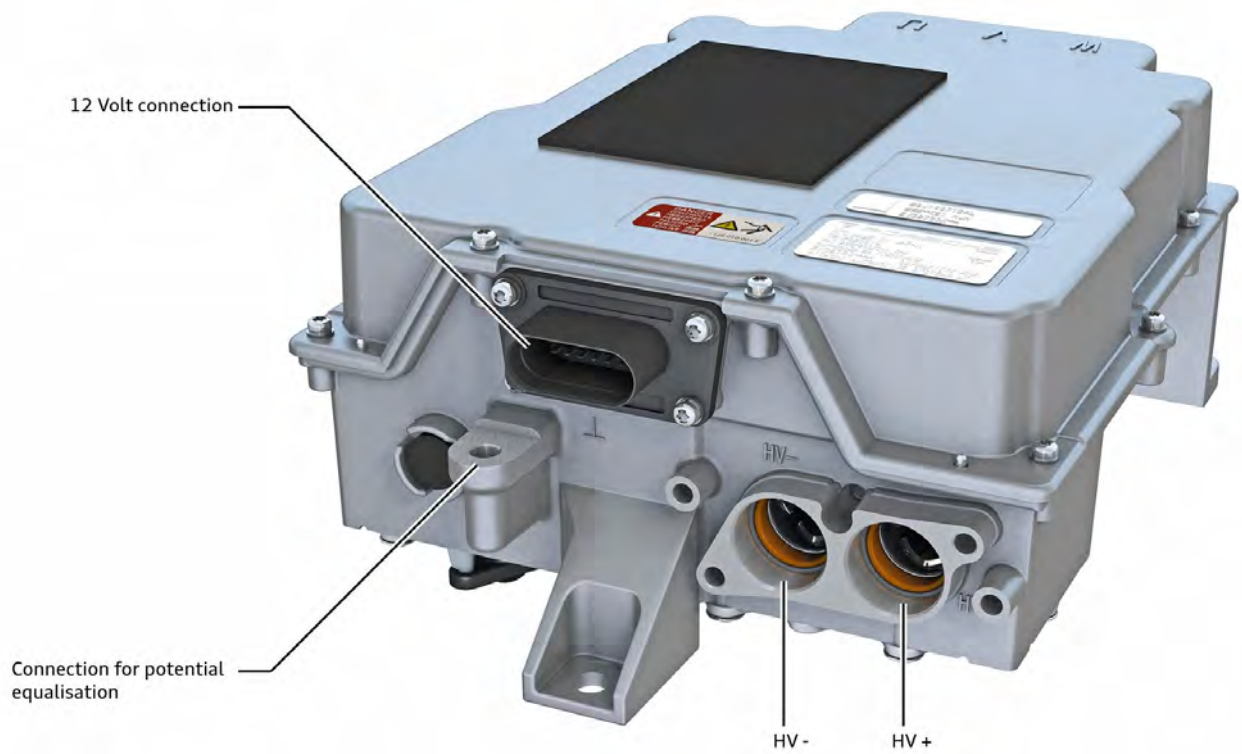

684_359a

Electric drive control unit for front axle J1234 converts direct voltage from the battery into three-phase alternating voltage for the electric drive motors. The direct voltage enters the power electronics via plug contacts. The electromagnetic compatibility filter ensures that no interference from the switching impulses can be transmitted into the system as a whole. There follows a group of several intermediate circuit capacitors which provide a uniform amount of energy to the IGBTs (insulated-gate bipolar transistors). During recuperation, the condensers also smooth the voltage used to charge the battery. Converted voltage enters the motor via the IGBTs. Current sensors monitor the motor's current draw on the alternating current and direct current side.

300 A pulse inverter

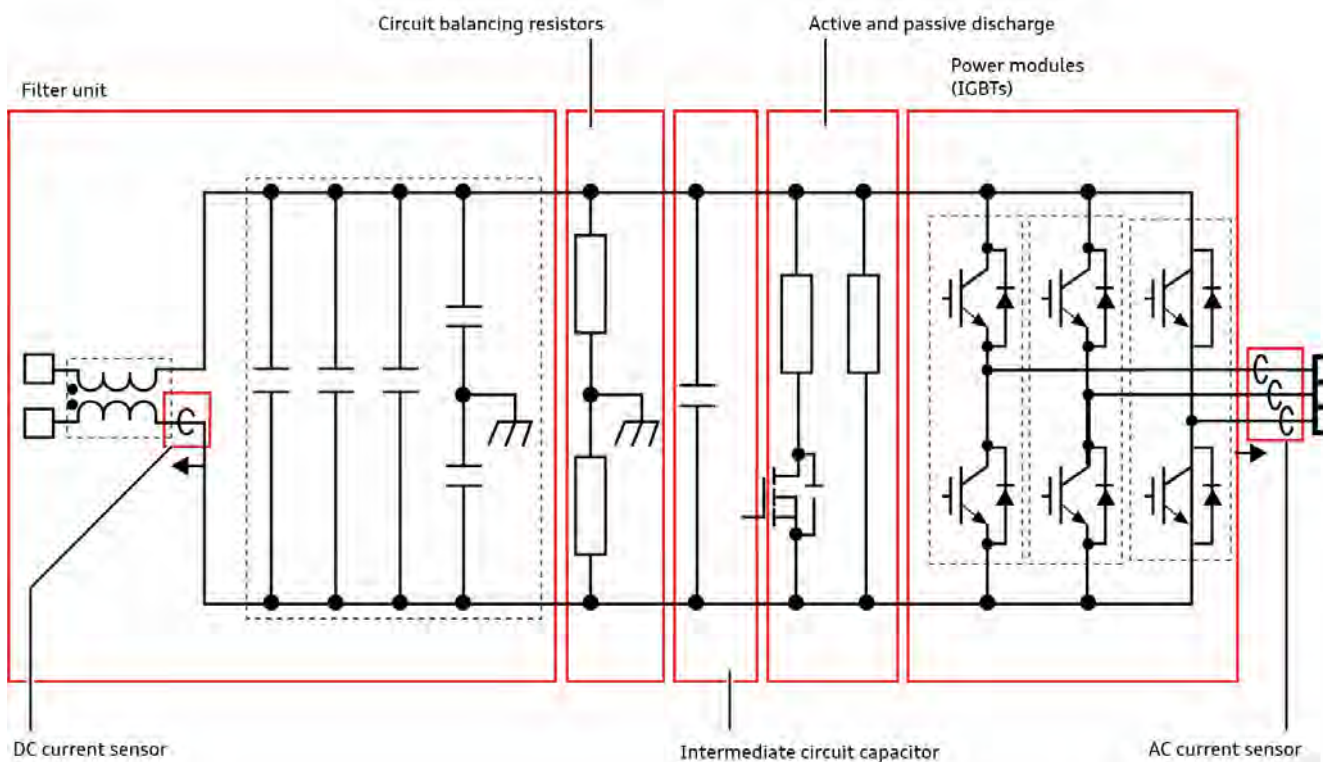

684_414

Electric drive control unit for rear axle J1235 (600 A version)

Electric drive control unit for rear axle J1235 is bolted onto the electric drive motor. However, the contacts are different to those on the front axle. The current bridge consists of bus bars with flexible elements.

Contacts on rear axle

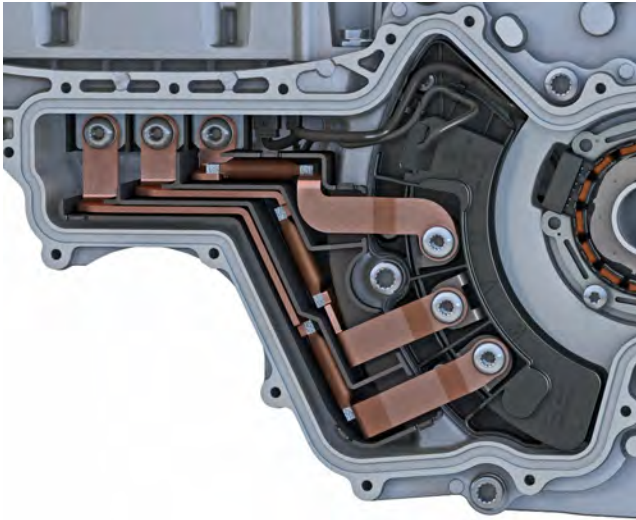

684_333



Note

Electric drive control unit for rear axle J1235 must under no circumstances be opened.

How the system works

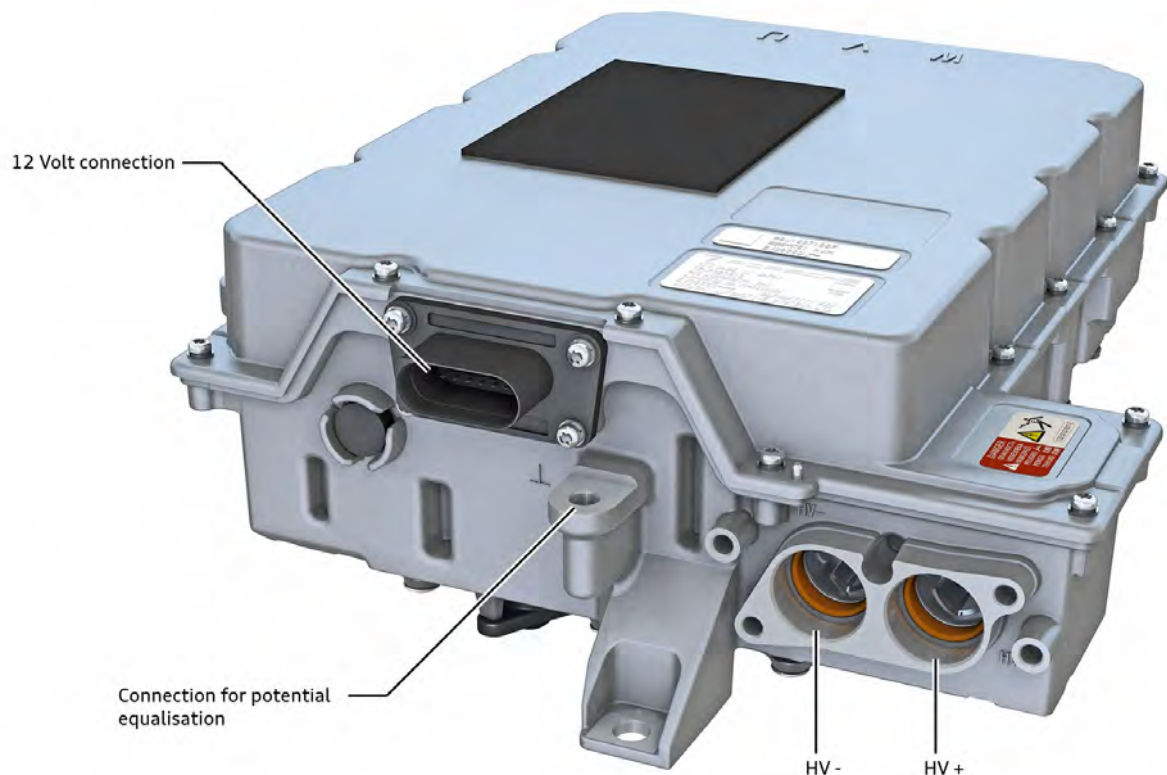

684_359b

Electric drive control unit for rear axle J1235 converts direct voltage from the battery into three-phase alternating voltage for the electric drive motors. As can be seen in the illustration, the design and functions of electric drive control unit for rear axle J1235 are practically identical to those on the control unit for the front axle. The only difference is that the number of IGBTs has been adjusted for the higher current. There are six power modules rather than three. The IGBTs are correspondingly connected together in parallel. Current sensors monitor the motor's current draw on the alternating current and direct current side.

The 300 ampere version is used on the Audi e-tron GT. On the RS e-tron GT, the 600 ampere version is used.

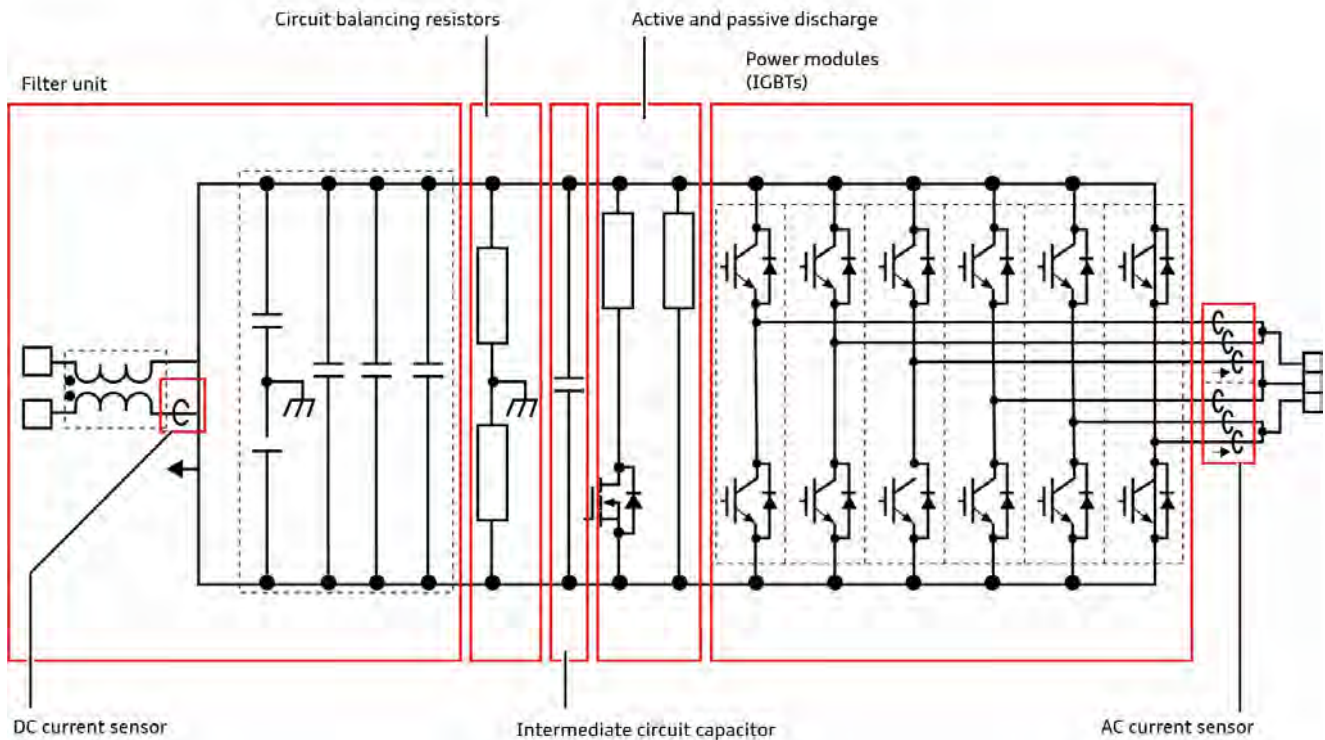

684_416

Networking/sensors

The power electronics are connected to the FlexRay and the CAN bus via the 12 Volt communication connection. There is also an input from the gearbox speed sender (rear axle only) and terminals 30, 31 and 15. The resolver and the temperature sensor are also directly connected to the power electronics. The designations of the temperature sensors are rear drive motor temperature sender G1096 and front drive motor temperature sender G1093. On the high-voltage side, the power electronics have five connections. Two of them are on the DC side (HV positive and HV negative for the high-voltage battery) and three are on the AC side (phase connections U, V and W).

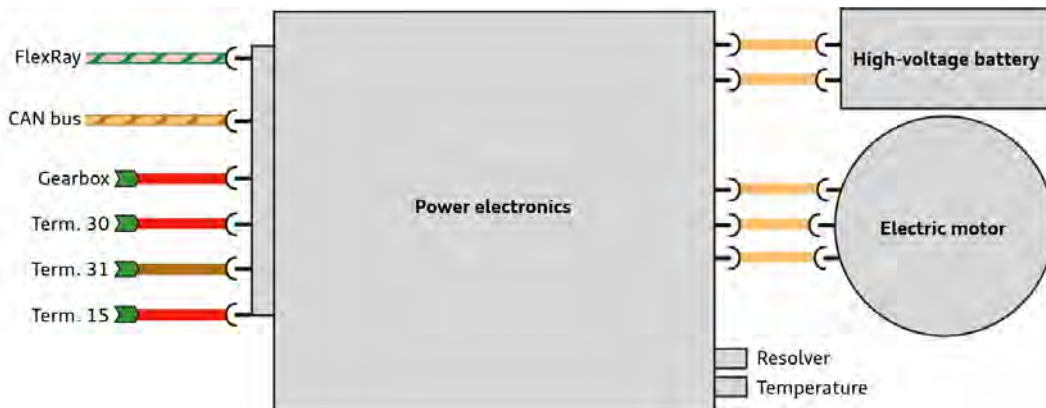

684_413



Note

If an electric drive motor or the power electronics are replaced in service, the new components must be adapted to each other. Please always refer to the current service literature.

Data processing

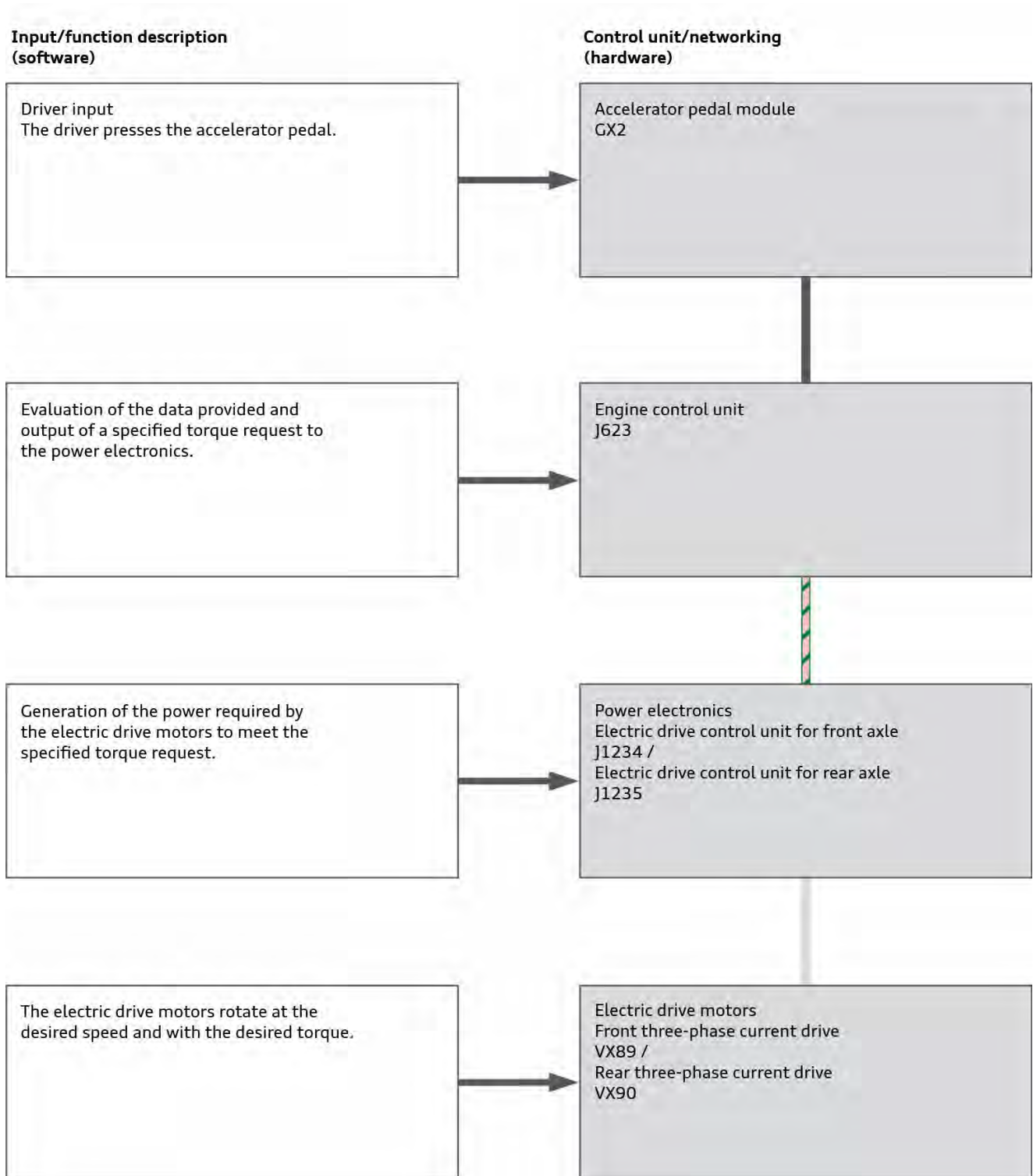

684_003

Key:

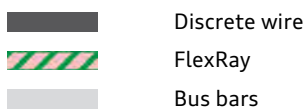

Driving dynamics

Launch control

A launch control system has been implemented for the Audi e-tron GT (type F8). This involves pre-tensioning the drive system when the brake pedal and the accelerator pedal are pressed at the same time.

Creep response

If the Audi e-tron GT (type F8) is on a level surface with a transmission position selected, the vehicle will begin to “creep”, as vehicles with an automatic gearbox do.

Transmission position D/S

There is no transmission position S on this vehicle project. The response of the electric drive motors is affected by the Audi drive select settings.

Driving away on a slope

When driving away on a slope without the brake or accelerator pedal pressed, the vehicle behaves differently depending on the situation.

Direction of travel	Transmission position	Action
uphill	D	Vehicle remains stationary
uphill	R	Vehicle rolls backwards
downhill	D	Vehicle rolls forwards
downhill	R	Vehicle remains stationary

If the vehicle remains stationary in a specific situation (refer to table), the ESC (ABS control unit J104) controls this input. As soon as transmission position N is selected via the selector lever, the vehicle starts to roll.

Recuperation settings

The strength of recuperation in overrun mode (brake pedal and accelerator pedal not pressed) can be set via the paddle levers on the steering wheel. Two levels of different strengths can be selected. The first level is much more noticeable to the driver than level 2. The maximum recuperation under braking is approx. 265 kW.

Coasting mode

If the vehicle is in coasting mode, the motor is set to 0 torque. This means that the motor cannot provide motor power or act as a generator.

Reversing

When the vehicle reverses, the rotating magnetic field reverses the electric motor’s direction of rotation. This means that the motor turns in reverse. The front motor is used as the main axle when reversing.

Electronic engine sound

Engine sound generator control unit 2 J1167 / engine sound generator control unit 3 J1177

On the Audi e-tron GT and the RS e-tron GT (type F8), an exterior sound system is available as standard. An interior sound system is available as an option. A warning sound at low speeds is required by law and this requirement is met (in the basic version) by a single loudspeaker. The system is known as AVAS (acoustic vehicle alerting system). The loudspeaker is fitted in the front section of the vehicle. Customers can also choose additional equipment where an additional loudspeaker is fitted at the rear of the vehicle along with two loudspeakers in the vehicle interior. Engine sound generator control unit 3 J1177 is fitted as part of this additional equipment. The two loudspeakers in the vehicle interior are fitted in the rear left and rear right doors. They are additional loudspeakers. The two control units control the sound that is experienced on the basis of speed, load and the Audi drive select mode selected. The technical implementation of country-specific regulations may mean that the sound is perceived differently depending on whether the vehicle is driving forwards or reversing. Retrofitting the optional equipment is not permissible due to legal restrictions.

Options in the EU:

Drive select mode	Front exterior loudspeaker	Rear exterior loudspeaker (optional)	Interior loudspeakers (optional)	Speed
efficiency	X			Becomes quieter at 25 km/h and above, no longer audible at 60 km/h and above
comfort	X	X		Exterior up to 220 km/h
dynamic	X	X (louder)	X	Exterior up to 220 km/h Interior up to 250 km/h

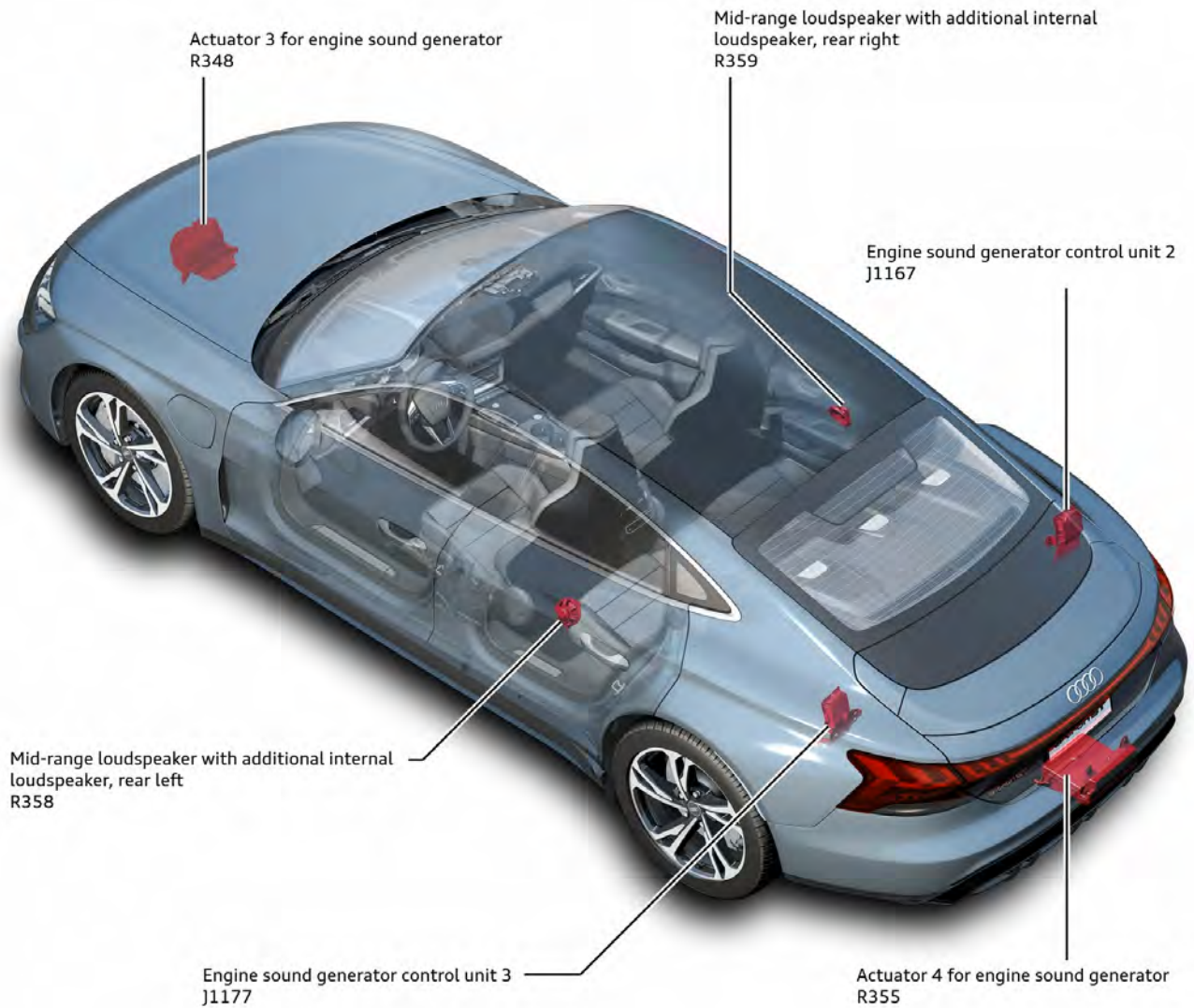

684_114

Power transmission

Overview

Two-speed transmission – OME
Audi e-tron GT: differential lock is optional equipment
Audi RS e-tron GT: differential lock is standard equipment

Electric drive motor for rear axle V663
Electric motor

The rear wheels are driven by rear three-phase current drive VX90

Electric drive control unit for rear axle J1235
Power electronics

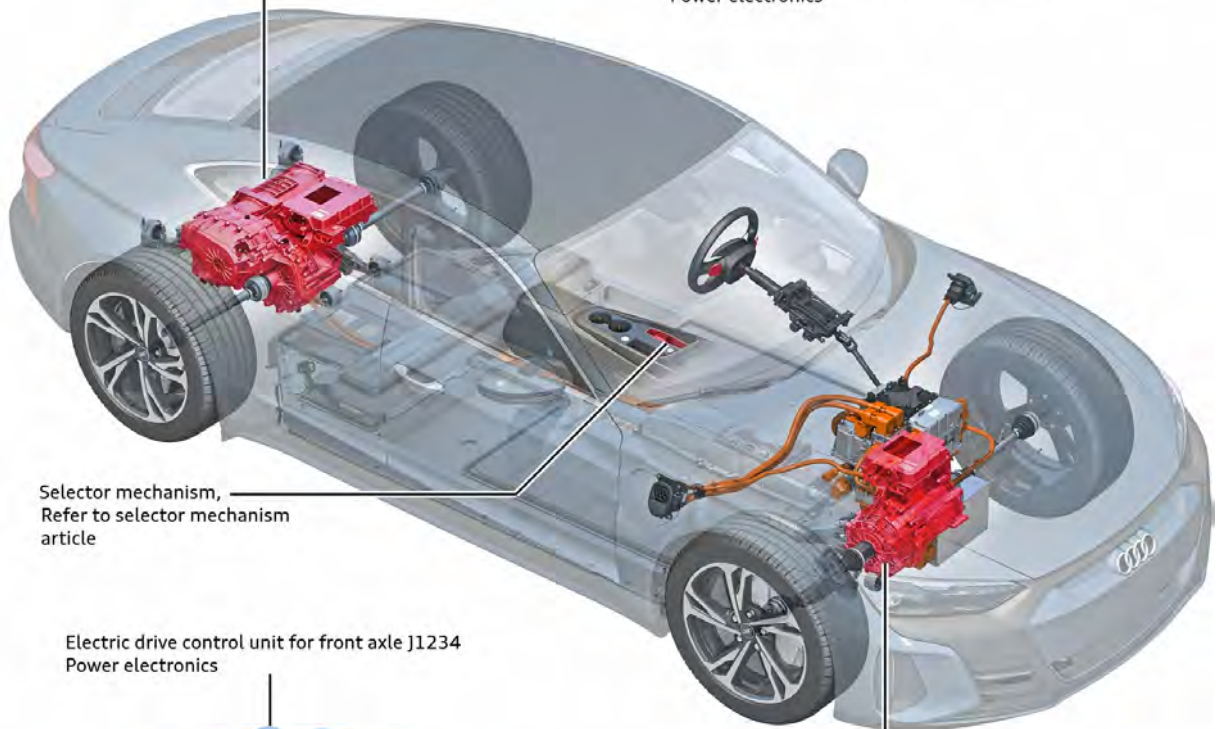

Selector mechanism,
Refer to selector mechanism article

Electric drive control unit for front axle J1234
Power electronics

Single-speed transmission – OMG

The front wheels are driven by front three-phase current drive VX89

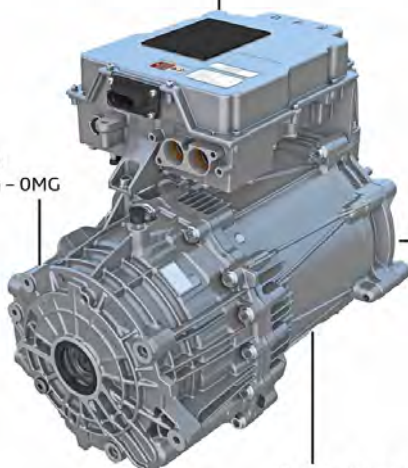

Electric drive motor for front axle V662
Electric motor

The Audi e-tron GT (type F8) is equipped with two three-phase current drives. They are regulated by motor control unit J623, which controls the drive torque via the power electronics.

In addition, the motor control unit is responsible for controlling the two-speed transmission OME.

Maximum torques at the axles

The two-speed transmission OME on the rear axle of the Audi e-tron GT increases both the driving dynamics and the efficiency of the vehicle.

The diagram gives a qualitative overview of the drive torques at the axles as a function of the speed, taking into consideration the gear set on the rear transmission unit.

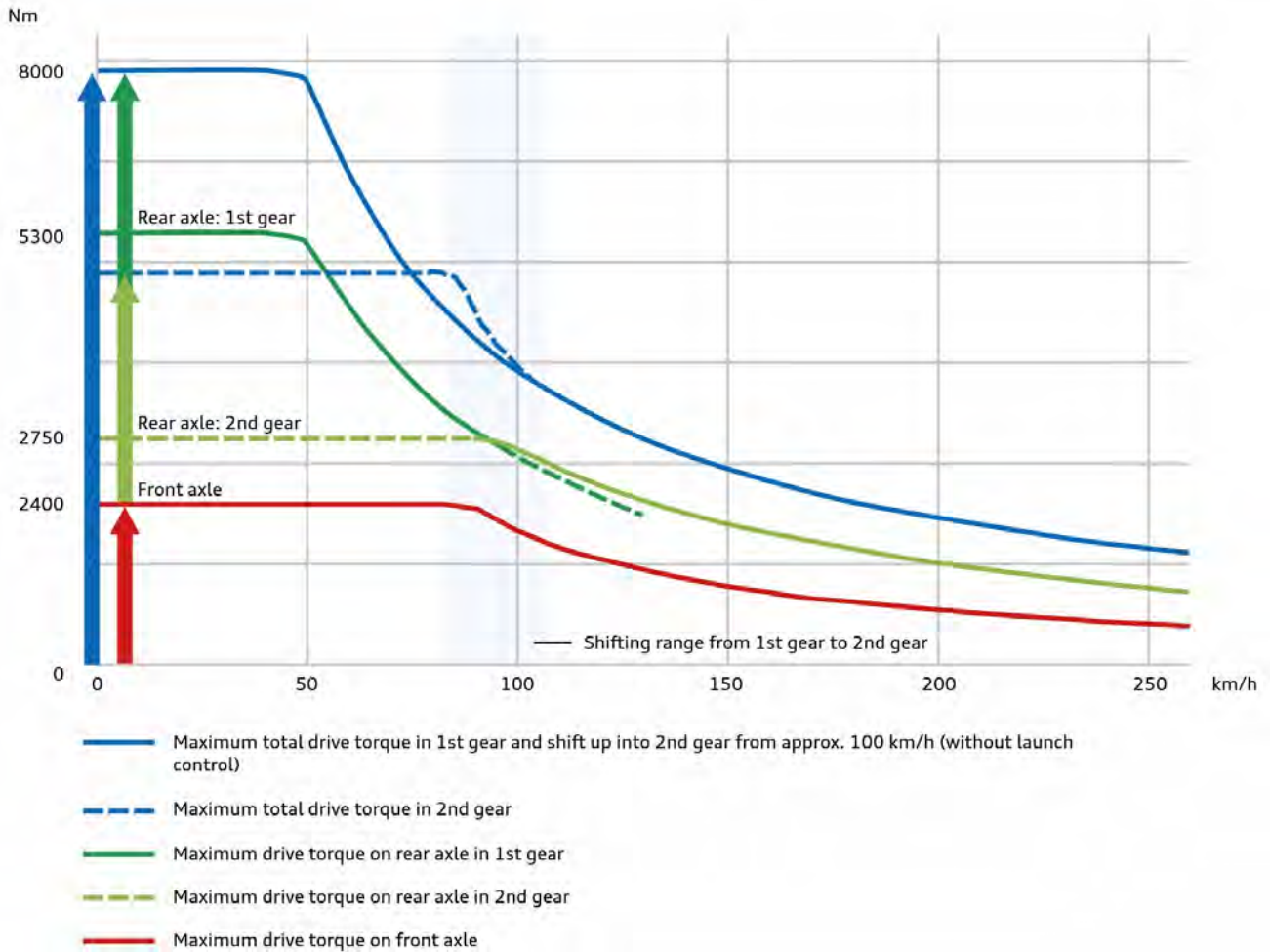

684_336

Selector mechanism

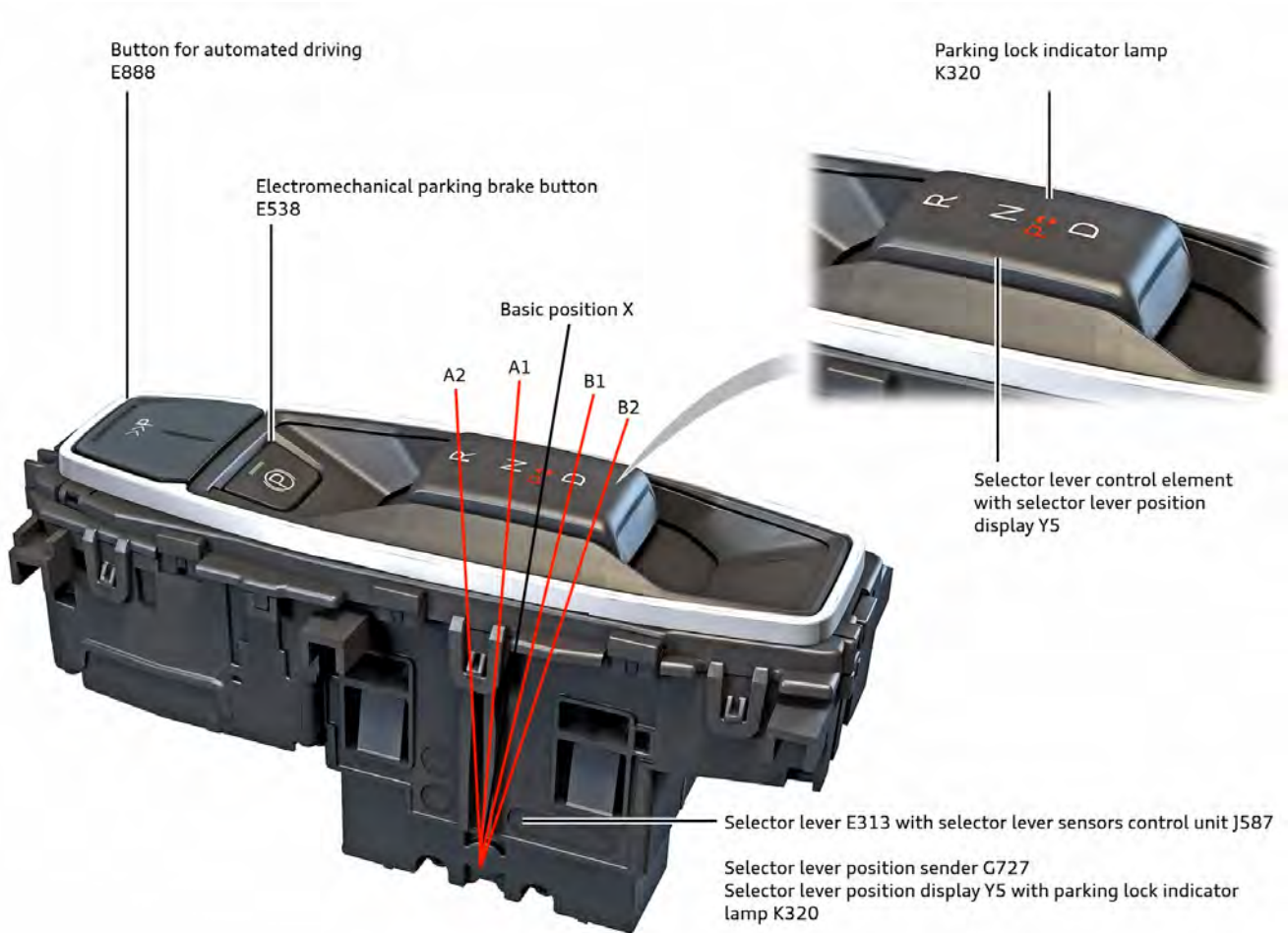

684_172

The driver's desired transmission position (R, N or D) is transmitted via the selector mechanism to motor control unit J623.

The data are transmitted to data bus diagnostic interface J533 via the infotainment CAN bus and from there to motor control unit J623 via FlexRay.

Transmission position D is the only position available for driving forwards. The gear selection can be influenced using the Audi drive select modes **efficiency, comfort and dynamic**.

The parking lock function is activated in conjunction with the electromechanical parking brake. This happens when button E538 is pressed to activate the parking brake when the vehicle is stationary, and this status is communicated to the motor control unit. It is also possible for the parking lock function to be activated via the Auto-P function as part of the exit concept.



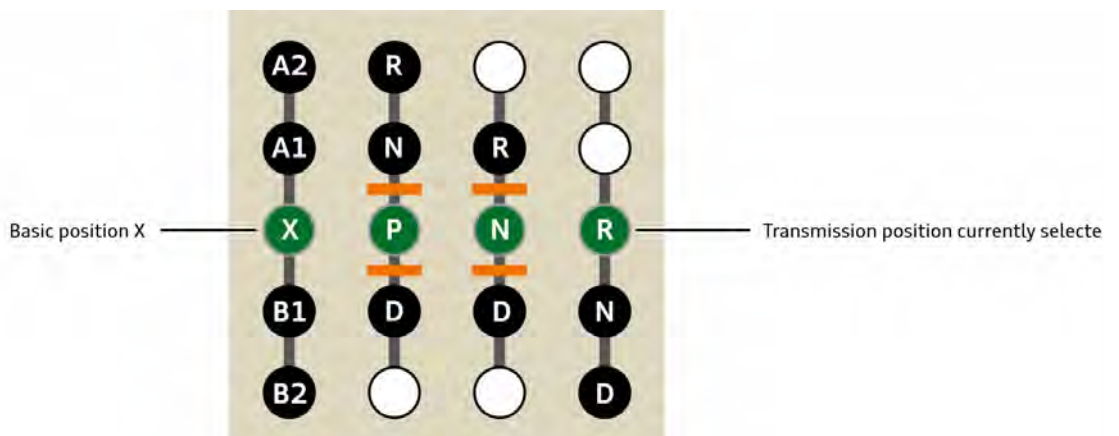

Shift schematic



684_166

From the basic position – X – there are two forward positions (A1, A2) and two rearward positions (B1, B2). The selector lever returns to the basic position – X – after every operation.

Key:

-  Basic selector lever position & current transmission position
-  Selectable positions which change the transmission position
-  Selectable positions which do not change the transmission position
-  Software lock – deactivation by pressing the brake pedal

Shift behaviour

When the vehicle is driven in transmission position D, 2nd gear is normally used for driving off. If transmission position R is selected and then position D, 1st gear remains selected. At driving speeds above approx. 20 km/h, the vehicle shifts into 2nd gear.

Manoeuvring, rocking the vehicle backwards and forwards to free it

The software lock is activated in transmission position N after approx. one second. This allows rapid changing of the transmission position from D to R and vice versa without applying the brake. This makes it easier to change transmission positions when manoeuvring. It also makes it possible to free the vehicle if necessary by rocking it forwards and backwards.



Note

A tone will sound briefly when R is selected.

Activating the parking lock function (P-ON)

The button for electromechanical parking brake E538 is marked with a white illuminated symbol.



If button E538 is pressed at vehicle speeds < approx. 2 km/h, the parking brake is actuated via ABS control unit J104. The parking brake brings the vehicle to a standstill by blocking the wheels on the rear axle.

The red symbol for the parking brake appears in the instrument cluster.



Directly after the rear wheels are blocked by the parking brake, the parking lock function is activated by blocking two-speed transmission unit OME on the rear axle. There is no physical parking lock. By engaging two gears simultaneously, the transmission unit blocks itself, which acts as a parking lock. Parking lock indicator lamp K320 lights up on the selector lever control.

Auto-P function (P-ON/OFF)

The parking lock function is activated automatically if the drive system is switched off when transmission position D or R is selected and the vehicle is stationary.

If the vehicle's drive system is activated, the parking lock function is deactivated when the driver presses the brake pedal and selects transmission position D, R or N.

Exit concept (P-ON)

The parking lock function is automatically activated if the driver's door is opened and the driver's seat belt is unbuckled when the vehicle is stationary with transmission position D or R selected.

Transmission position N

The parking lock function remains deactivated (P-OFF): Car wash function

The parking lock function remains deactivated if the ignition is switched off when transmission position N is selected. A 30-minute countdown starts, during which time the parking lock function remains deactivated. After approx. 30 minutes, the parking lock function is activated automatically. The countdown is interrupted if the ignition is switched on or the vehicle begins to move.

Function diagram – selector mechanism

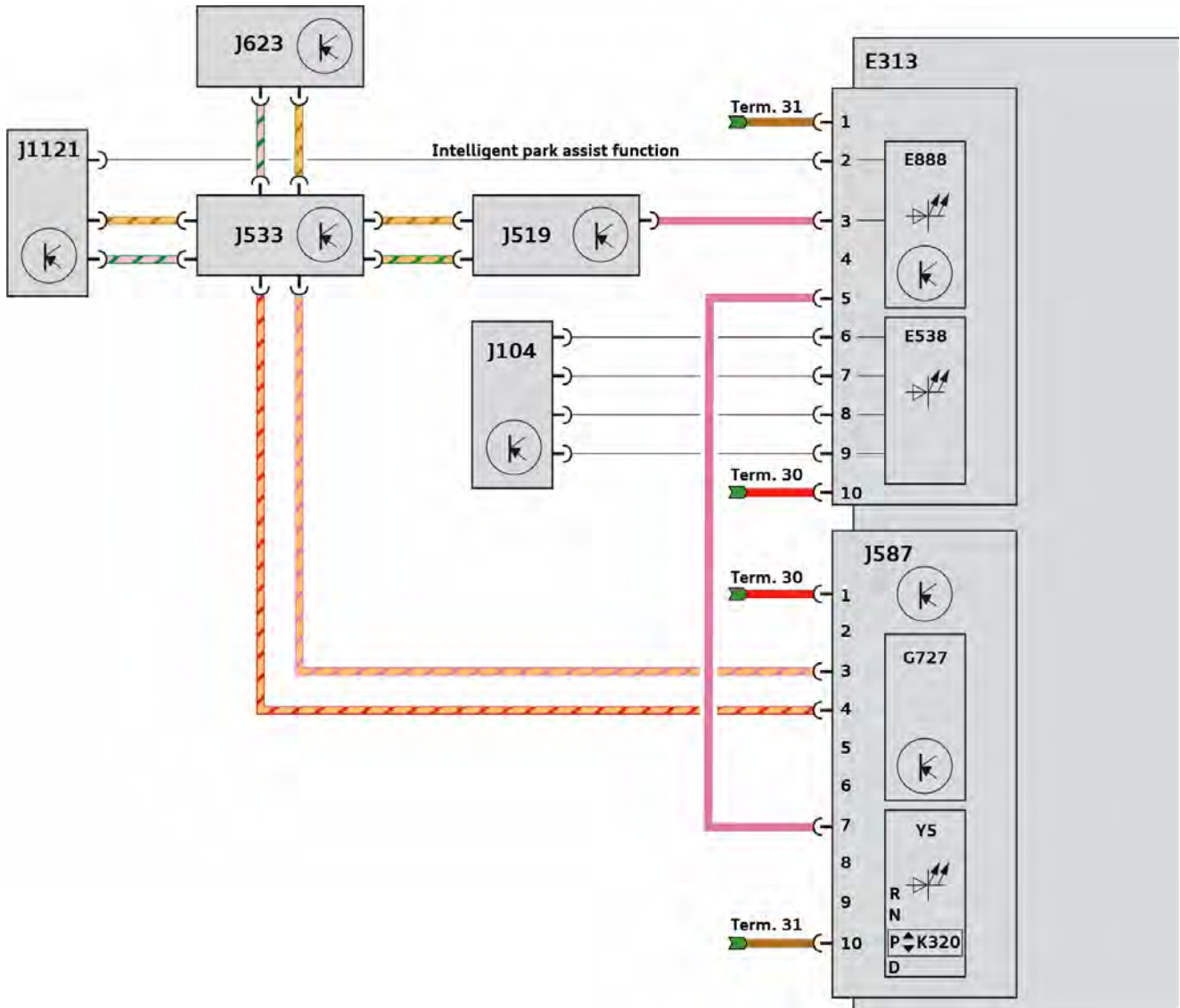

684_169

Key:

E313 Selector lever with:

- E538 Electromechanical parking brake button
- E888 Button for automated driving
- G727 Selector lever position sender
- J587 Selector lever sensors control unit
- Y5 Selector lever position display with K320 parking lock indicator lamp

- J104** ABS control unit
- J519** Onboard supply control unit
- J533** Data bus diagnostic interface
- J623** Motor control unit
- J1121** Driver assist systems control unit

- Earth wire
- Positive wire
- LIN bus
- FlexRay
- FlexRay Low
- Convenience CAN, high



Convenience CAN, low



CAN bus High (Infotainment)



CAN bus Low (Infotainment)

Single-speed transmission – OMG

Single-speed transmission – OMG has the factory designation EQ450-1K. It comprises two planetary gear stages on a common shaft. They are referred to as the input stage and the output stage.

The planetary gear stages reduce the speed of the electric motor with a reduction ratio of $i = 8.053$ for forwards driving and reversing.

The torque, which is increased according to the ratio, is transmitted to the wheels via a planetary gear differential.

The transmission unit is flanged onto the electric drive motor; together with the intermediate housing of the electric drive motor, this forms an area with a separate oil supply. As the gears are submerged in the oil pan, they churn the oil upwards. This lubricates and cools the components. The gear oil is cooled via the cooling system for the electric drive motor. The heat is exchanged via the intermediate housing of the electric drive motor.

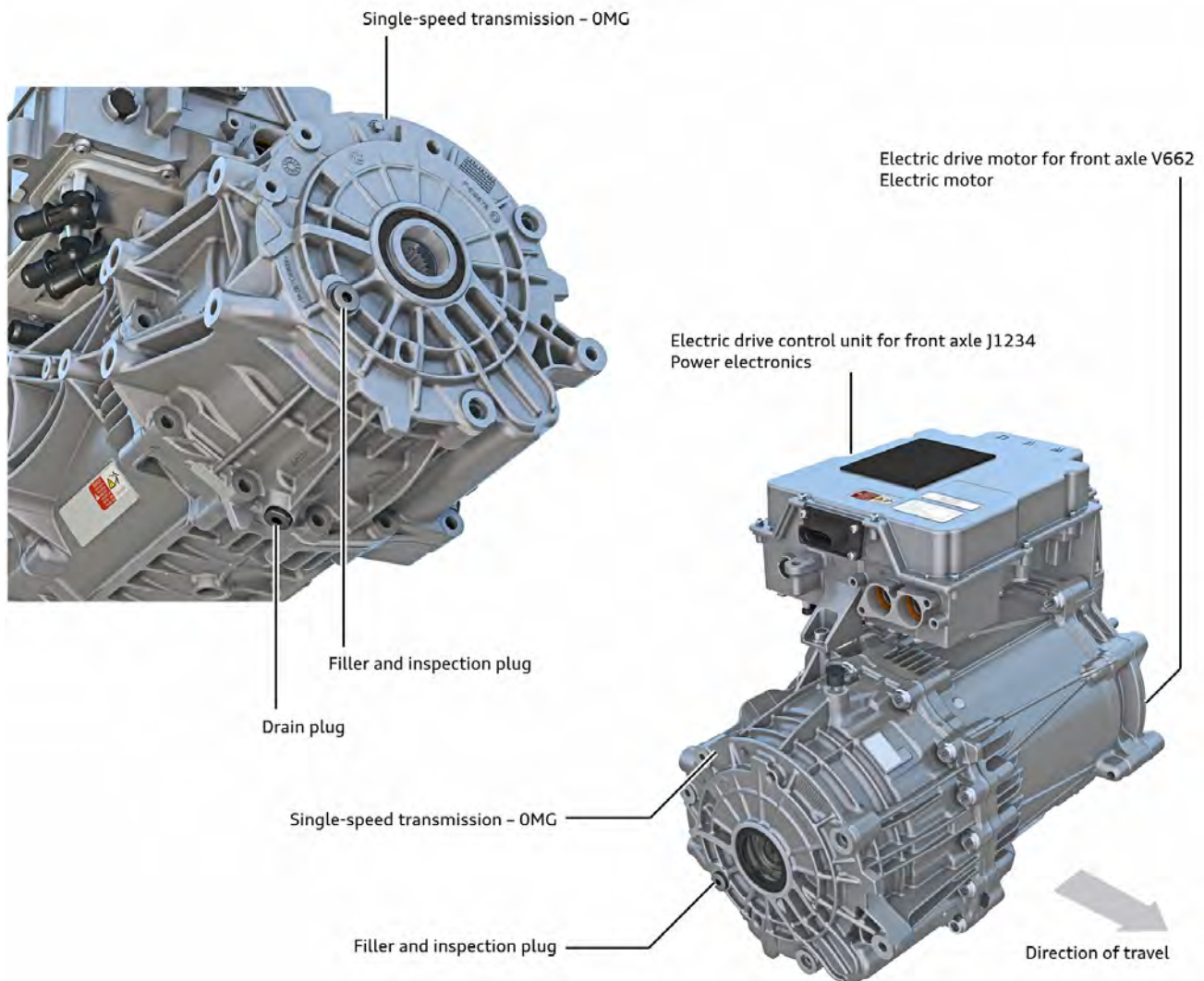

684_173

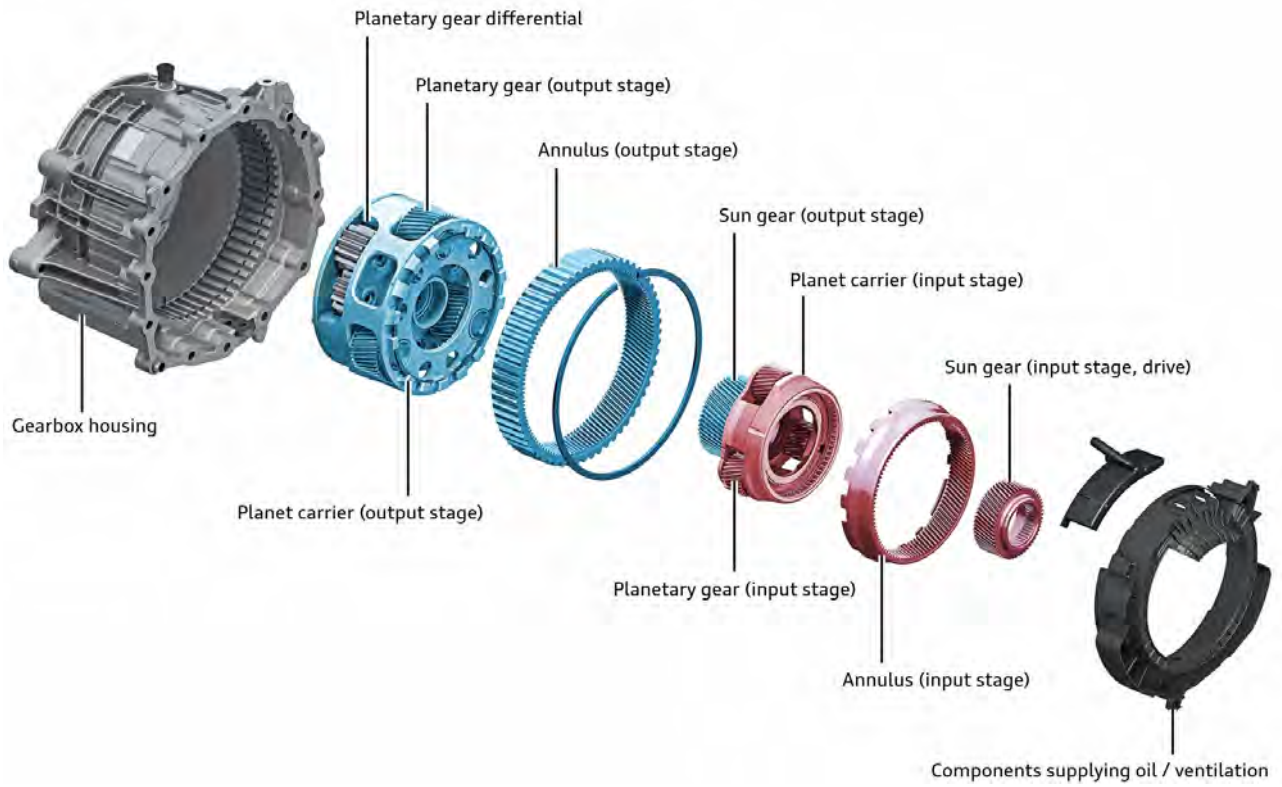

684_064

Key:

- Planetary gear set - output stage
- Planetary gear set - input stage

Transmission schematic

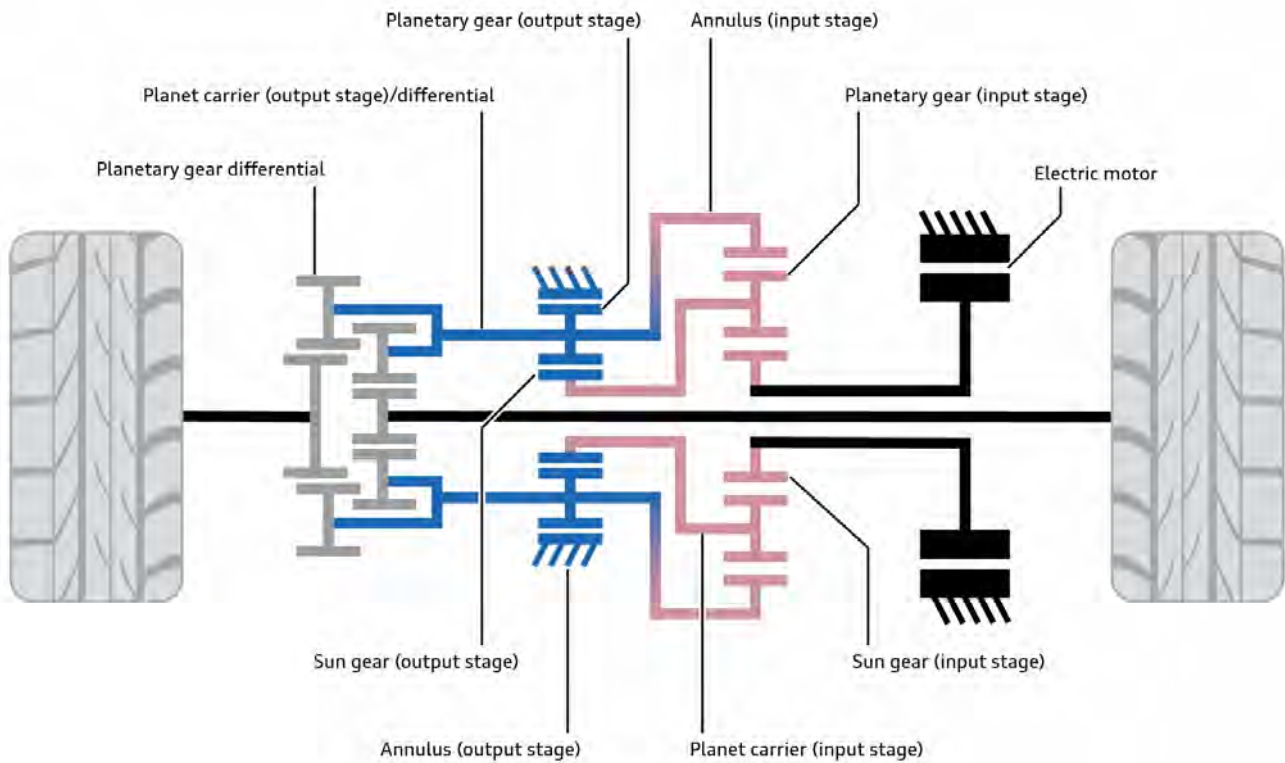

684_177

The electric drive motor transmits the torque via the sun gear into the input stage. The torque is transmitted to the planet carrier of the output stage via the annulus of the input stage. The planetary gears of the output stage transmit torque to the stationary annulus and the sun gear of the output stage, which in turn transmit torque to the planet carrier of the input stage. The torque is transmitted from the planet carrier of the output stage to the planet carrier of the planetary gear differential, and via its differential gears and sun gear to the axles and the wheels.

Planetary gear differential

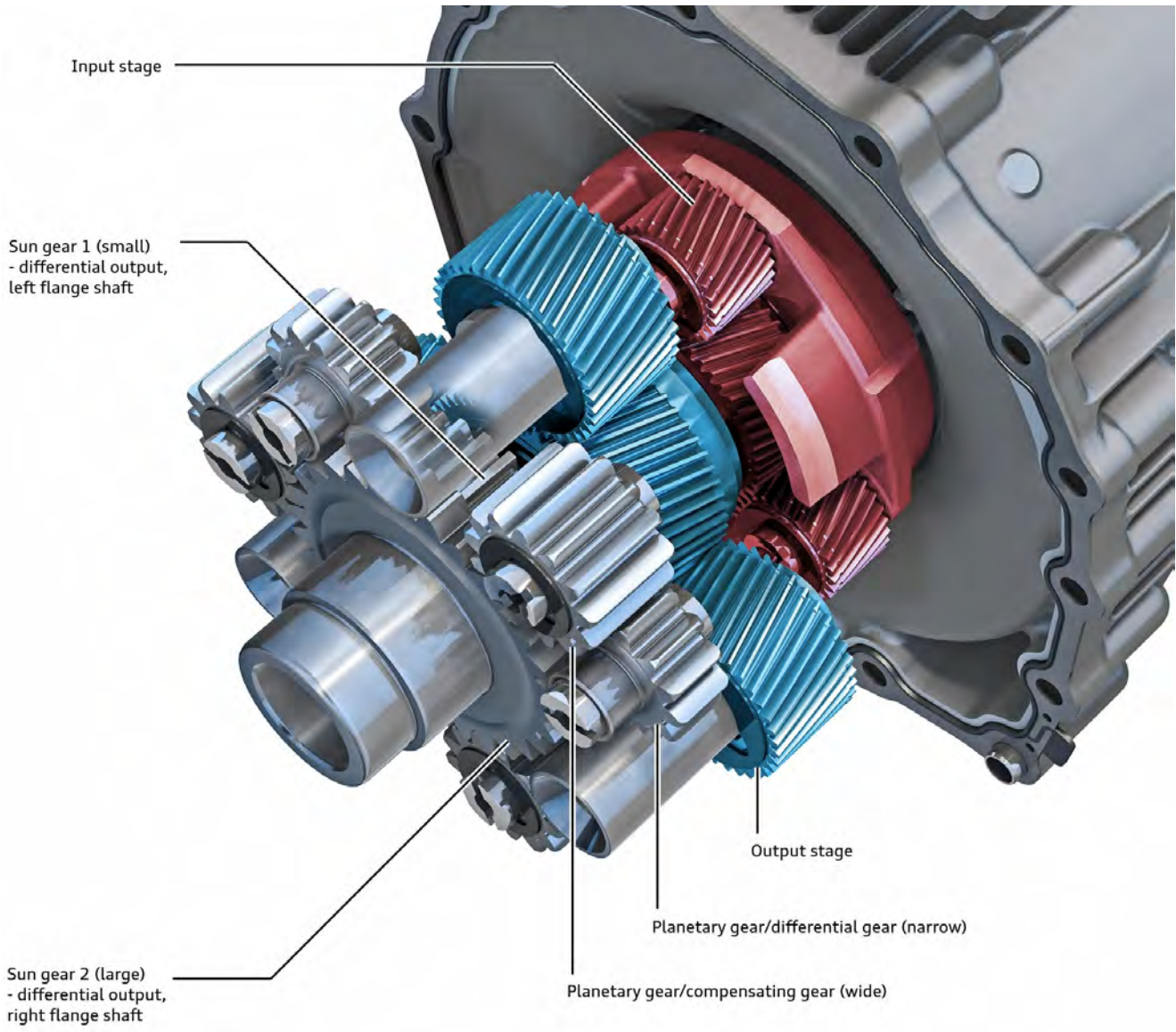

684_174

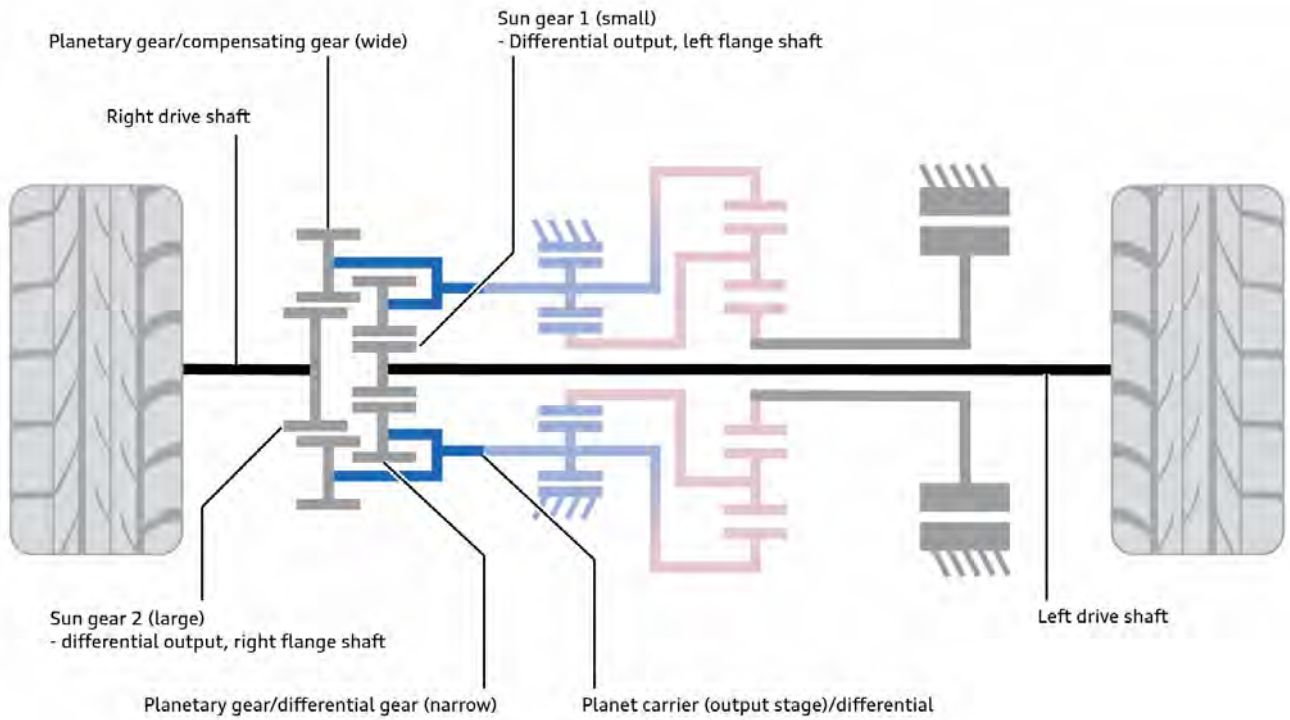

684_186

The torque is transmitted via the planet carrier of the output stage to the differential gears (planetary gears of the differential). The planet carrier of the output stage also serves as the planet carrier of the planetary gear differential. The differential gears transmit the torque further to the axles via the sun gears.



Reference

For further information on the planetary gear differential, please refer to SSP 675 "Audi e-tron (type GE)" (refer to article "Lightweight planetary gear differential").

Two-speed transmission OME

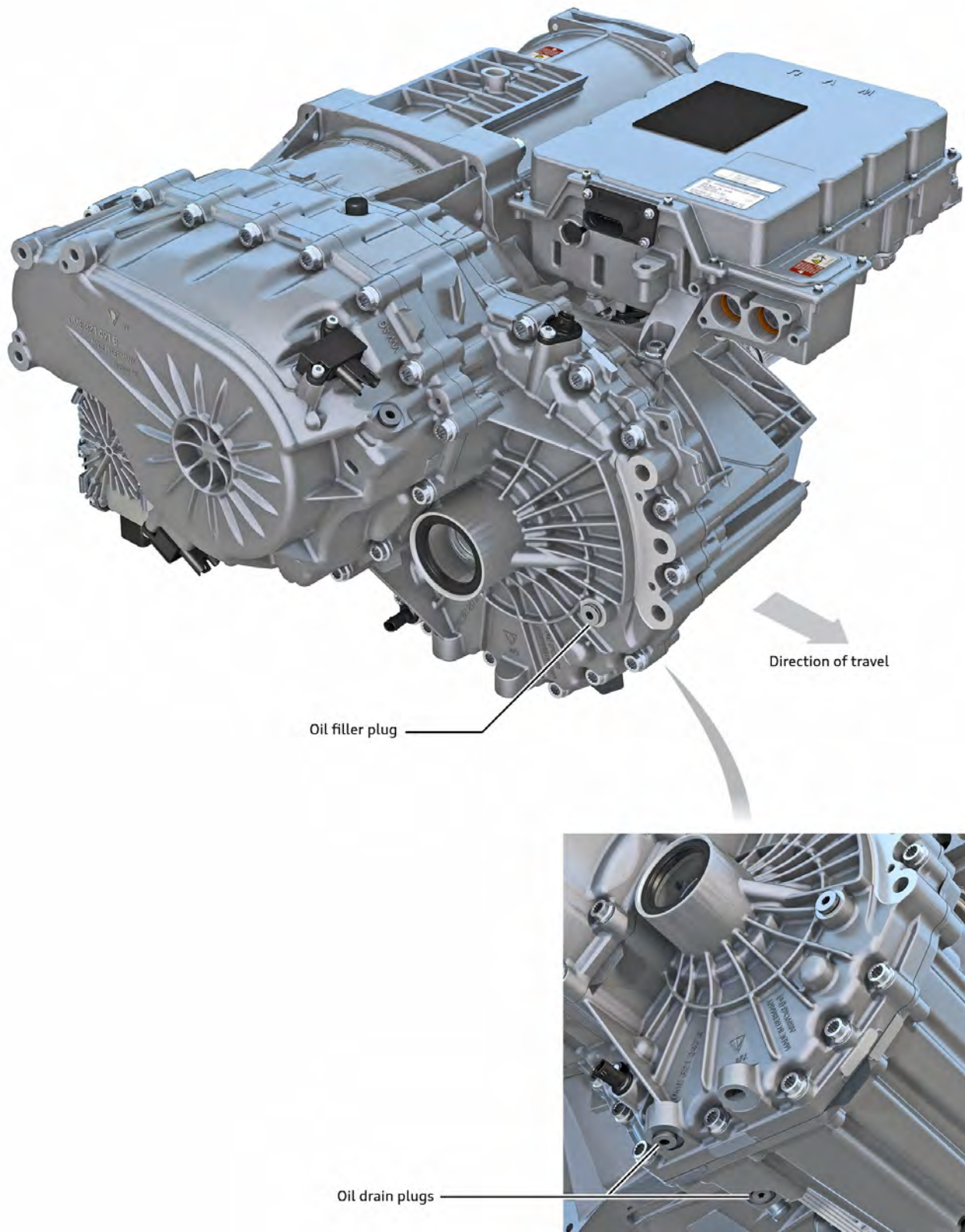

684_339

The Audi e-tron GT (type F8) is fitted with two-speed transmission unit OME on the rear axle as standard equipment. The transmission unit is fitted parallel to the axle and has two continuous speed reduction stages and one planetary gear set. The transmission unit has the factory designation EQ550-2P.

An active differential lock is available as optional equipment for the Audi e-tron GT. This active differential lock is standard equipment on the Audi RS e-tron GT.



Reference

You can view the components of two-speed transmission unit – OME in detail using the AR application AR "Audi e-tron GT (Type F8) - Drive / Power Transmission".

Three selector elements - a freewheel, a dog clutch and a multi-plate clutch- enable the transmission unit to perform the following tasks:

- › Shifting between 1st and 2nd gear. The different ratios are achieved using a planetary gear set.
- › Reversing in transmission position R. This is done by reversing the direction of rotation on the electric drive motor in 1st gear and engaging the dog clutch for power transmission.
- › Activating the parking lock function. This is done by blocking the gears and locking them in position.
- › Enabling neutral position.

The shift matrix shows the interaction between the selector elements required for the transmission functions.

Transmission position/gear	Ratio
1 (R/N)	15,560
2	8,160

Transmission position D is the only position available for driving forwards. The gear selection can be influenced using the Audi drive select modes **efficiency, comfort and dynamic**.

Exploded view

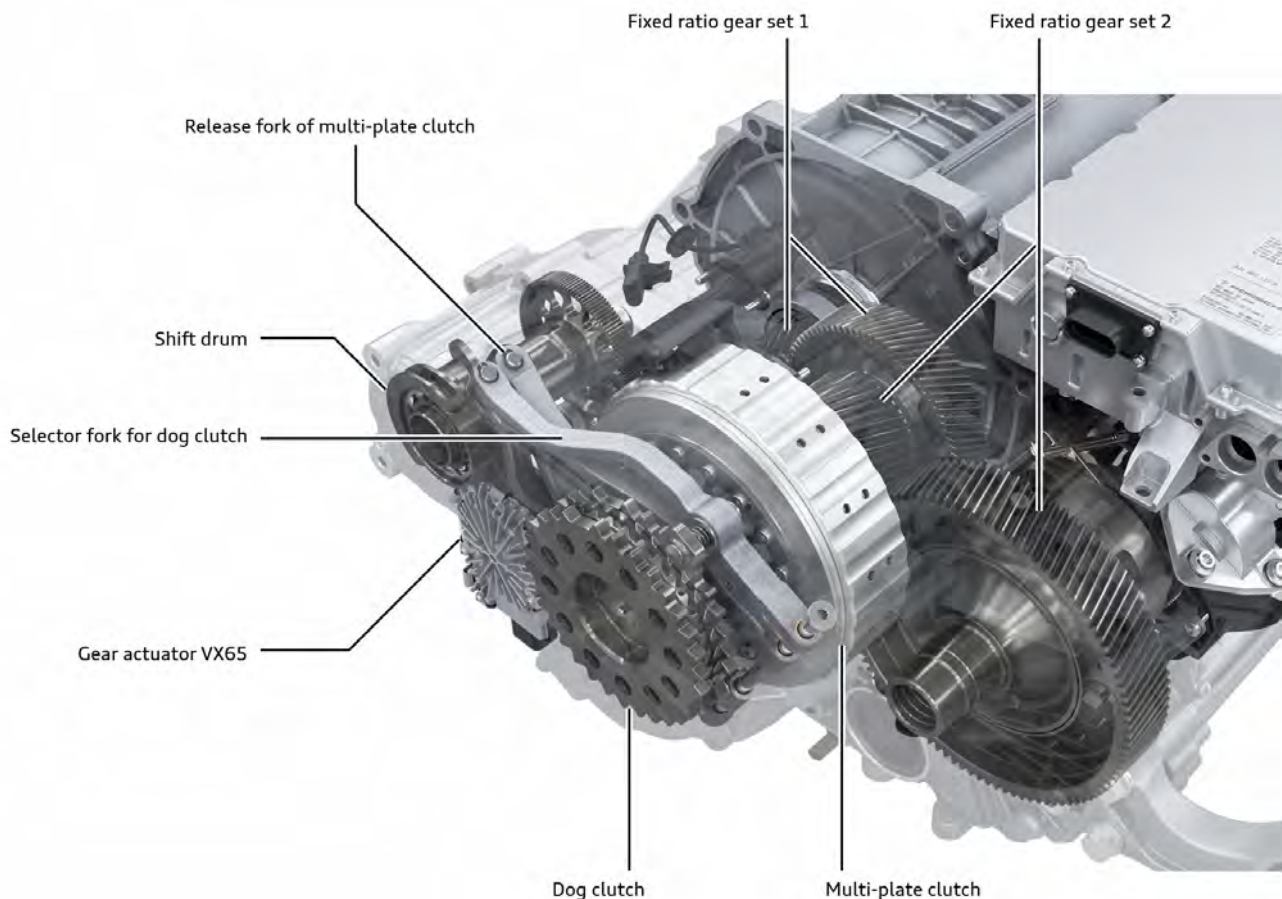

684_370

The multi-plate clutch and dog clutch are operated via the selector fork and the release fork, which are controlled by the shift drum.

The shift drum is actuated by gear actuator VX65 via a spur gear drive.

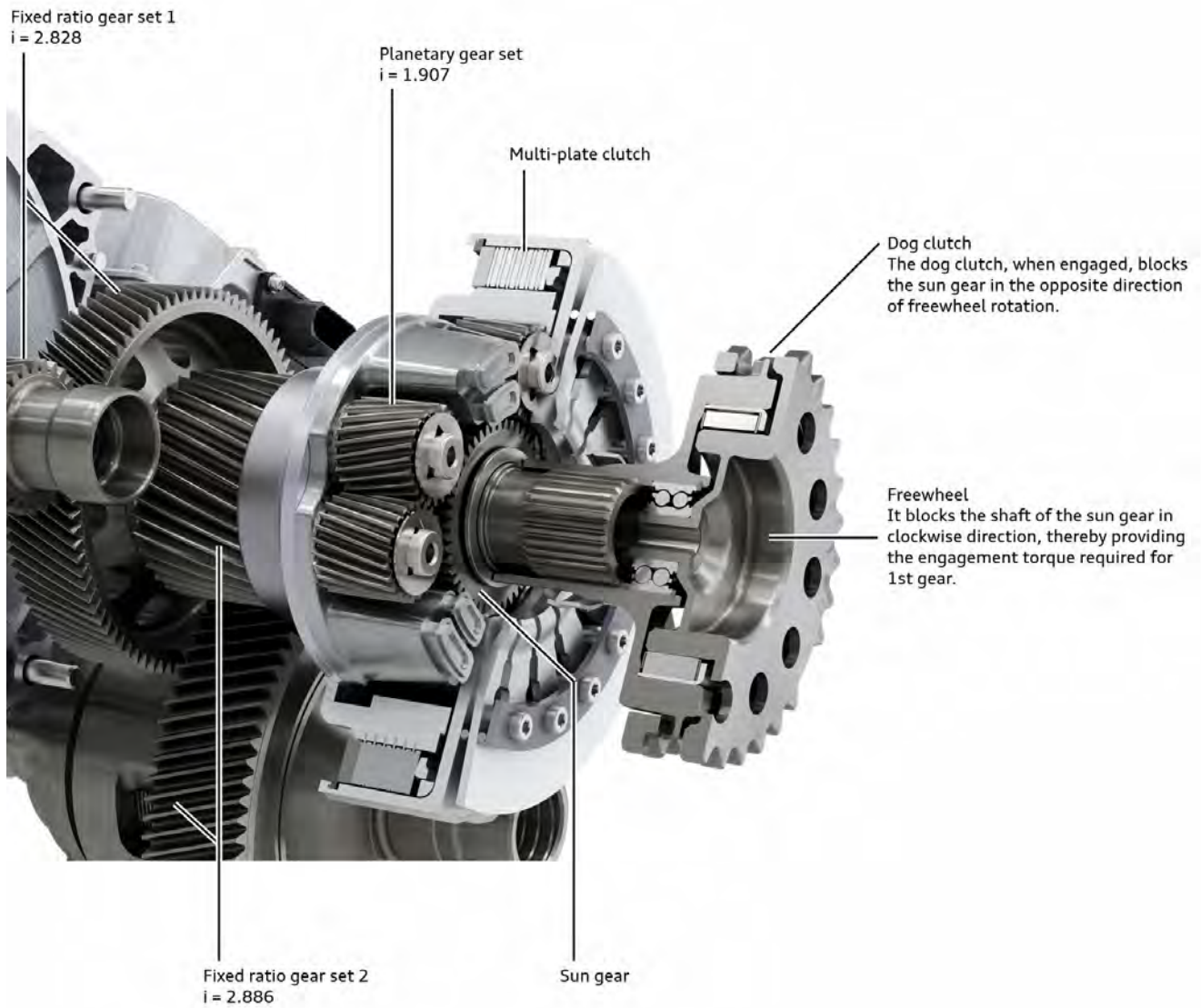

684_369

The two fixed-ratio gear sets 1 and 2 are always involved in the power transmission and yield a constant ratio of $8.16 : 1$. This ratio corresponds to that of 2nd gear, as here the planetary gear set is blocked, and therefore rotates without speed transformation (i.e. $1 : 1$).

For 1st gear and reverse gear, the planetary gear ratio of 1.907 is applied. Together, the two gear ratios (8.16×1.907) yield a ratio of $15.56 : 1$.

There is no physical neutral position in the transmission unit. This means that the electric drive motor is always engaged for power transmission to the wheels.

Freewheel

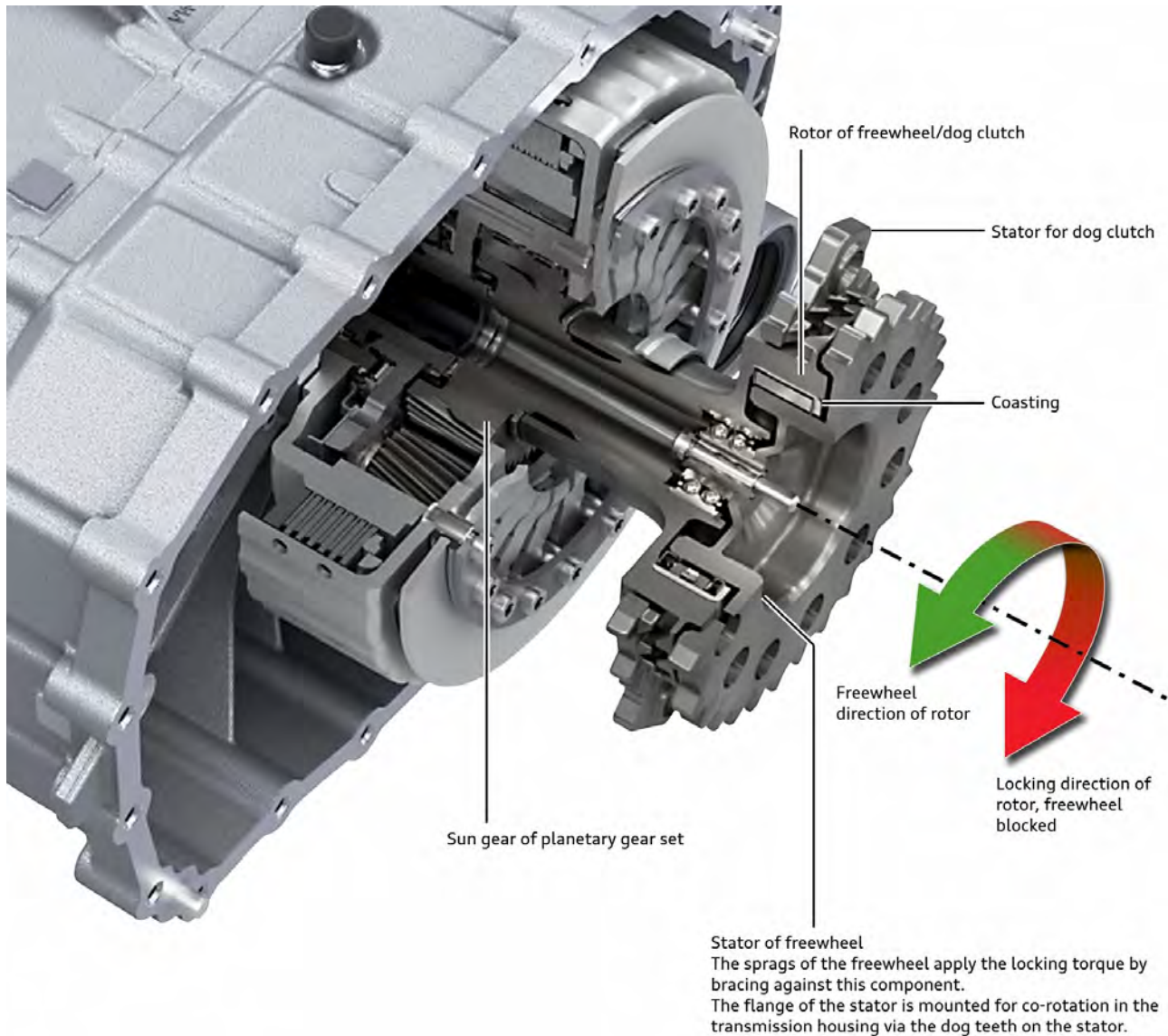

684_367

The freewheel is one of the three selector elements of two-speed transmission OME. It provides the basis for 1st gear, for shifting from 2nd gear back to 1st gear, and for the parking lock function. Its task as a component is to block the sun gear from turning in one direction, and to ensure free rotation in the other direction (i.e. of freewheel rotation).

The rotor of the freewheel interlocks with a shaft journal connecting it to the sun gear. The stator of the freewheel has a flange with dog teeth that allow it to be mounted for co-rotation in the transmission unit housing.

On the end of the rotor of the freewheel are teeth for the dog clutch. When the dog clutch is engaged, these teeth interlock with the teeth on the stator of the dog clutch and block the sun gear in the direction of freewheel rotation.

This means that the sun gear is blocked in both directions when the dog clutch is engaged.

The shift matrix shows the interactions between the selector elements that are required for the transmission functions.



Note

The term “freewheel” has two meanings:

- › A component that blocks the rotation of a shaft in one direction (locking direction) and allows the shaft to turn freely in the other direction.
- › A state in which kinetic energy allows the vehicle to roll along freely. This is also referred to as coasting.

Dog clutch

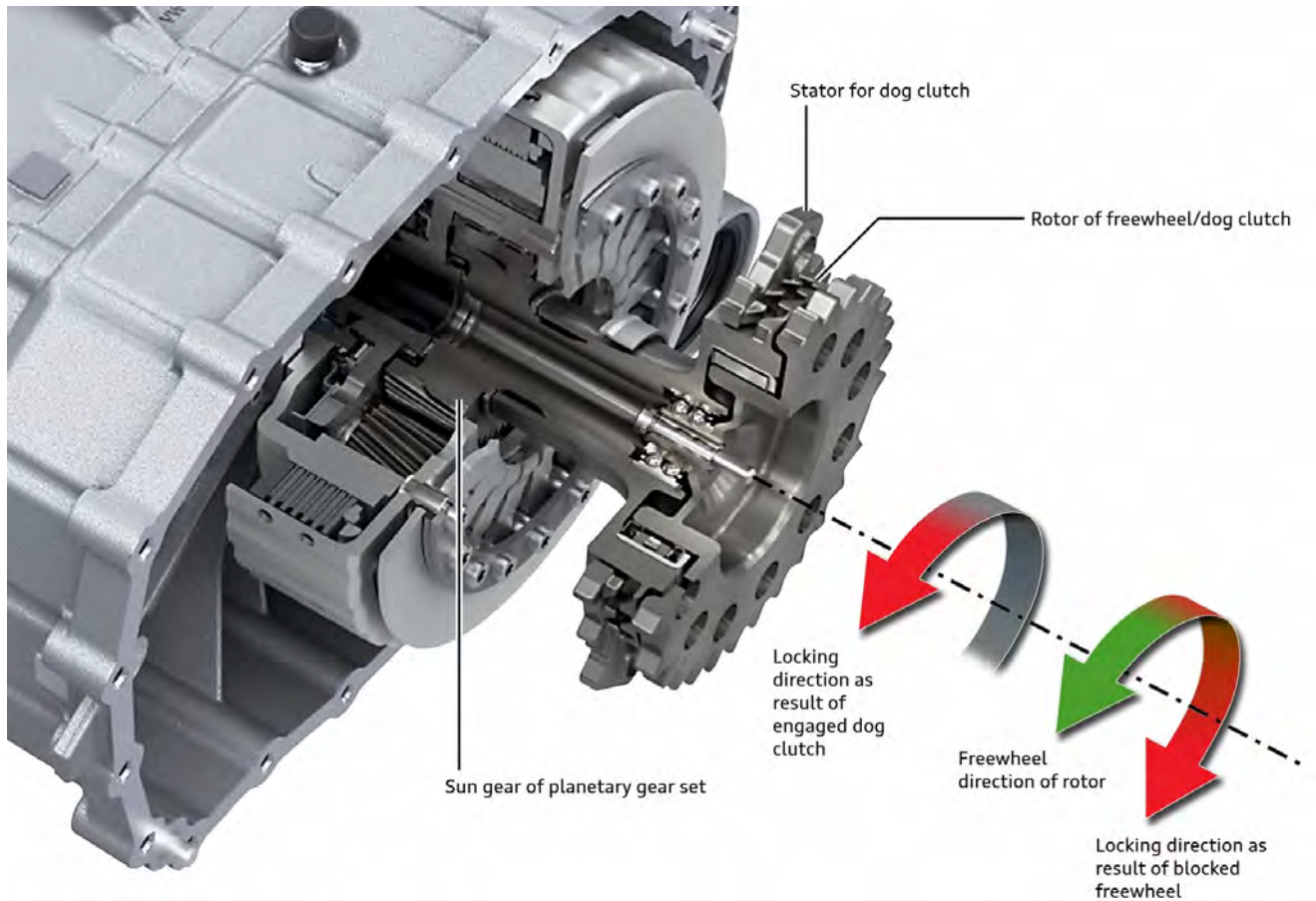

684_368

The dog clutch is one of the three selector elements of two-speed transmission OME. It is required for reverse gear, recuperation in 1st gear, and the parking lock function.

When the dog clutch is engaged, it blocks the rotor in the direction of freewheel rotation.

As the rotor interlocks with a shaft journal connecting it to the sun gear, the sun gear is blocked in both directions of rotation when the dog clutch is engaged:

- › In one direction of rotation by the freewheel
- › In the other direction of rotation by the dog clutch

The stator of the dog clutch is mounted for co-rotation in the transmission housing via the dog teeth on the stator. It is engaged and disengaged by a selector fork that moves it along a shaft in the transmission unit housing. When engaging the clutch, the selector fork slides the stator towards the rotor, and the dog teeth on the side of the stator mesh with the dog teeth on the rotor.

The shift matrix shows the interactions between the selector elements that are required for the transmission functions.

Actuation of the dog clutch

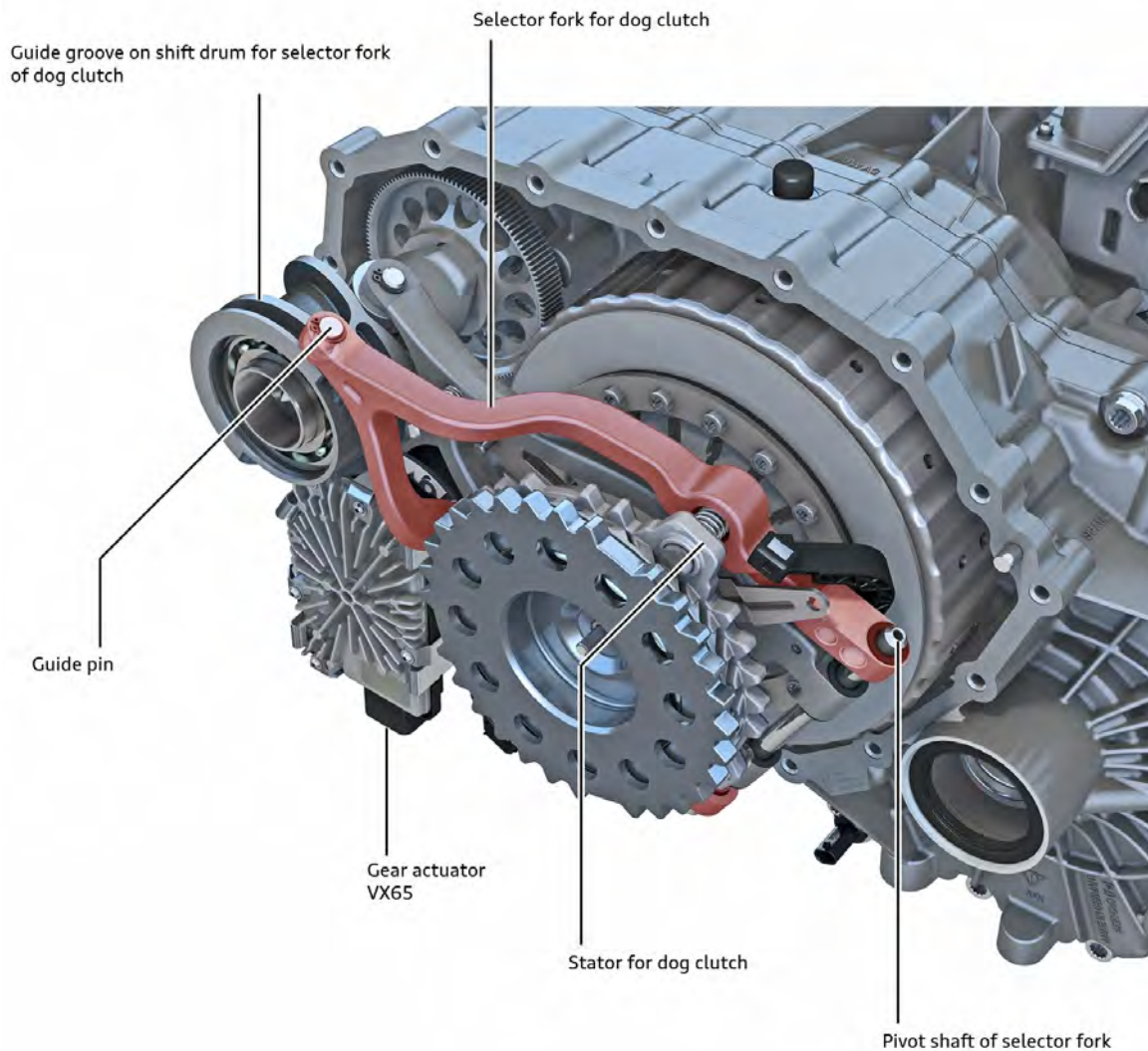

684_270

When the shift drum rotates, the guide pin engaged in the guide slot causes the selector fork to extend.

This causes the stator to be moved back and forth via the two spring-loaded joints connecting it to the selector fork.

When the dog clutch engages, the stator is moved towards the rotor. The spring-loaded joint ensures that the selector fork does not block when the dog teeth are aligned tooth on tooth. If this happens, it causes the dog teeth to be pre-loaded and to engage, and the dog clutch engages as soon as the rotor turns.

Motor control unit J623 detects the “tooth on tooth” position via clutch jaw position sensor G1016. In order to engage the dog clutch, the electric drive motor is actuated minimally, if necessary, so that the rotor turns far enough for the dog teeth to engage, and sensor G1016 detects a fully engaged dog clutch.

Dog clutch, disengaged

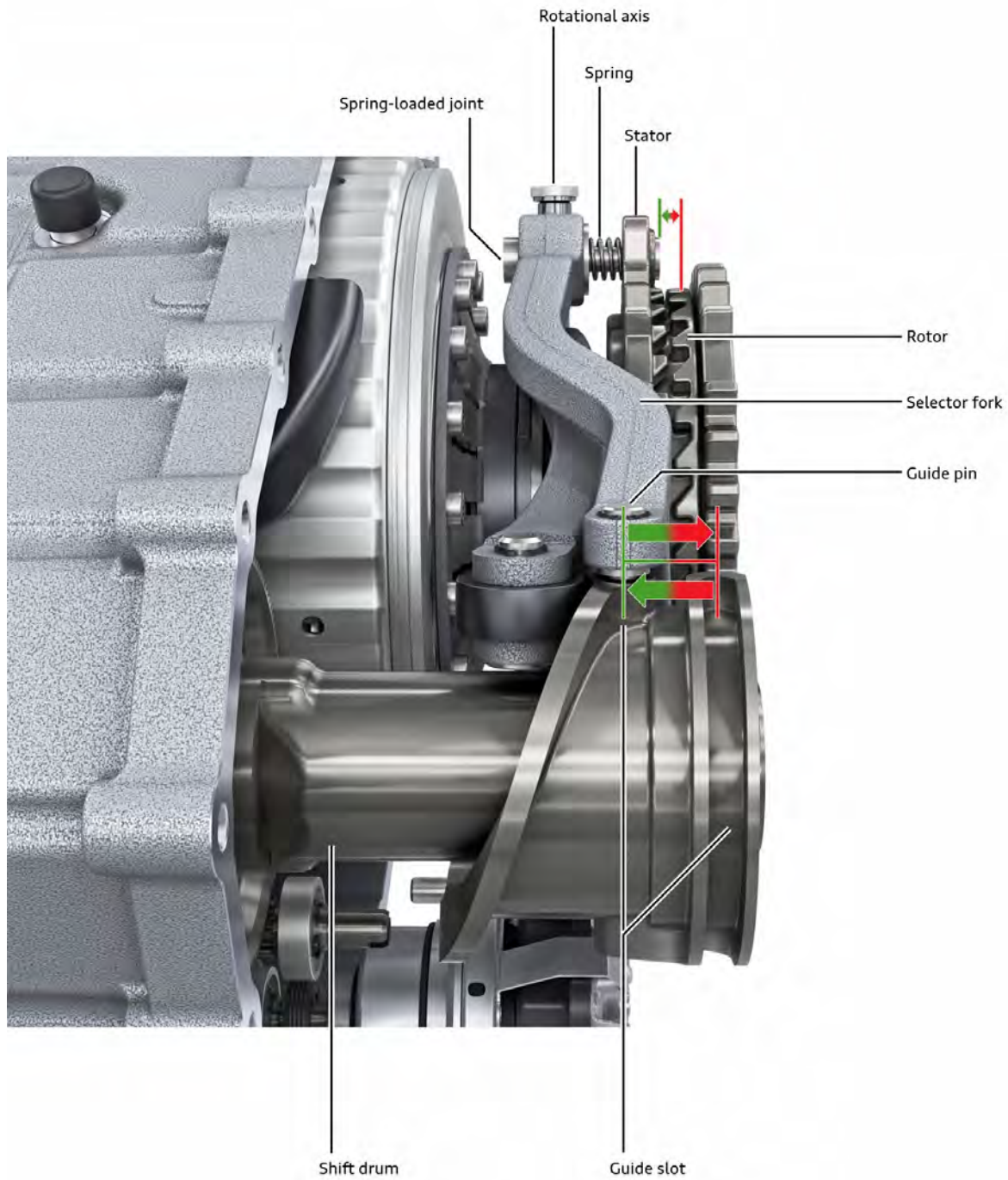

684_366

Key:



Dog clutch engaging/engaged



Dog clutch disengaging/disengaged

Points to note regarding how the dog clutch is operated

Dog clutch aligned tooth on tooth



684_363

Dog clutch engaged



684_364

The freewheel exhibits a certain degree of elasticity when subjected to torque in the direction of rotation in which it blocks. The greater the torque the freewheel is subjected to, the more it rotates slightly in the direction in which it blocks. This causes the rotor of the dog clutch to rotate as well.

This effect is exhibited in situations such as:

- > Powerful acceleration in 1st gear
- > Parking on an incline when the parking lock function is activated and the parking brake is not engaged

If this happens, the dog clutch may engage when there is minimal overlap in the “tooth on tooth” position due to the rotation of the freewheel under high torque. In this situation, there is a risk that the freewheel springs back when the torque eases off, causing the dog clutch to be pre-tensioned in such a way that it cannot be disengaged again.

If the dog clutch cannot be released, it is not possible to shift up from 1st into 2nd gear.

To prevent the situation described here, the dog clutch is prevented from engaging when shifting from 2nd gear back into 1st gear at high loads. In this case, the shift drum remains in shift state C (dog clutch still disengaged), (refer to image “684_337”). As recuperation in 1st gear requires the dog clutch to be engaged, recuperation is not possible at this stage.

The dog clutch is not engaged until the operating conditions are no longer critical.

Multi-plate clutch

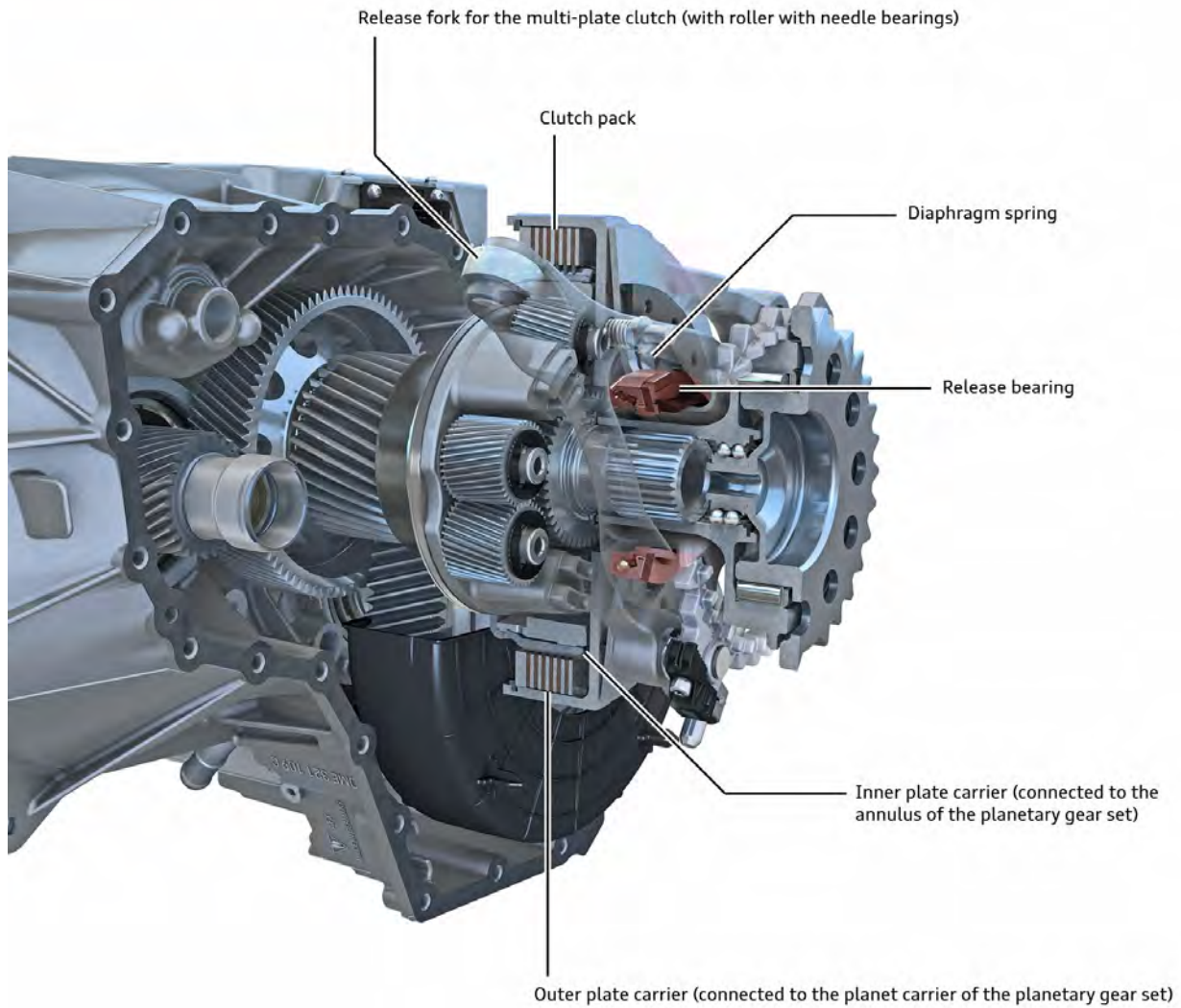

684_269

Two-speed transmission OME is equipped with a multi-plate clutch that is closed by a diaphragm spring when the clutch is not operated.

When the multi-plate clutch is closed, it connects the planet carrier with the annulus. As a result, the planetary gear set is blocked and co-rotates as a unit. No speed reduction takes place in the planetary gear set.

This shift state is required for 2nd gear and for the parking lock function.

Disengaging/engaging the clutch

Angled guide on shift drum for release fork of multi-plate clutch

Diaphragm spring

Release fork for multi-plate clutch (with roller with needle bearings)

Pivot shaft of selector fork for dog clutch and release fork of multi-plate clutch

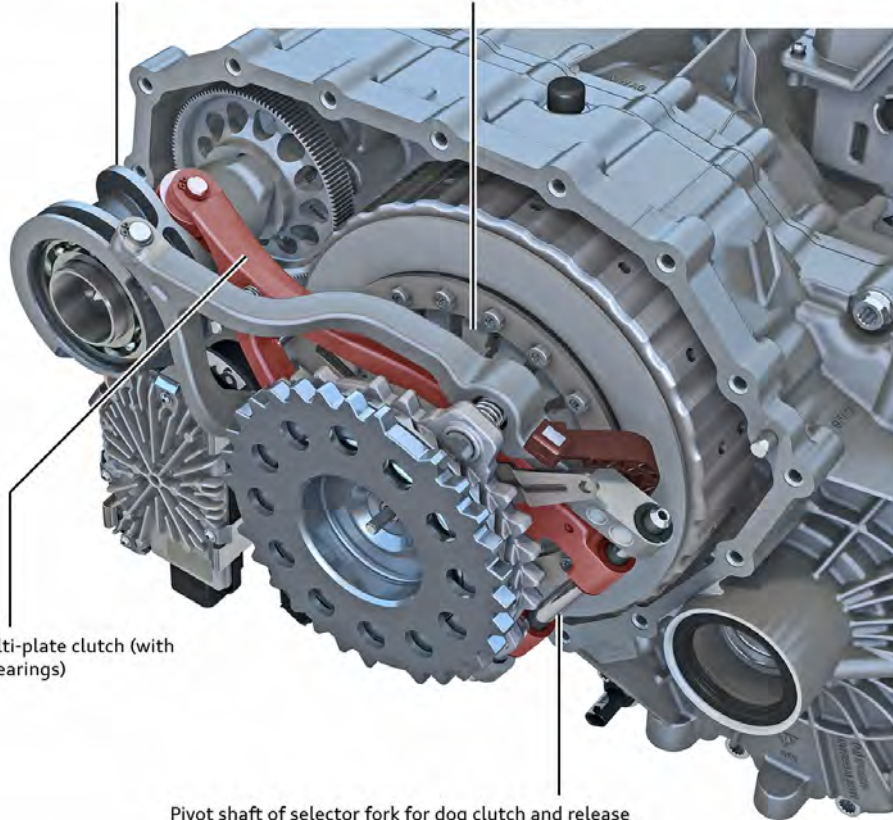

684_289

The shift drum actuators are responsible for disengaging/engaging the multi-plate clutch.

An angled guide on the shift drum actuates the release fork for the multi-plate clutch via a roller with needle bearings. The release fork actuates the release bearing to disengage and engage the multi-plate clutch.

When the multi-plate clutch is disengaged, the planetary gear set is no longer blocked.

The planetary gear set therefore serves as a speed reduction stage for 1st gear and reverse gear.

The multi-plate clutch is open when transmission position N is activated. This makes it possible to push the vehicle even if the dog clutch and freewheel are engaged.

The movement of the release fork is registered by clutch position sender G476.

Shift drum actuation

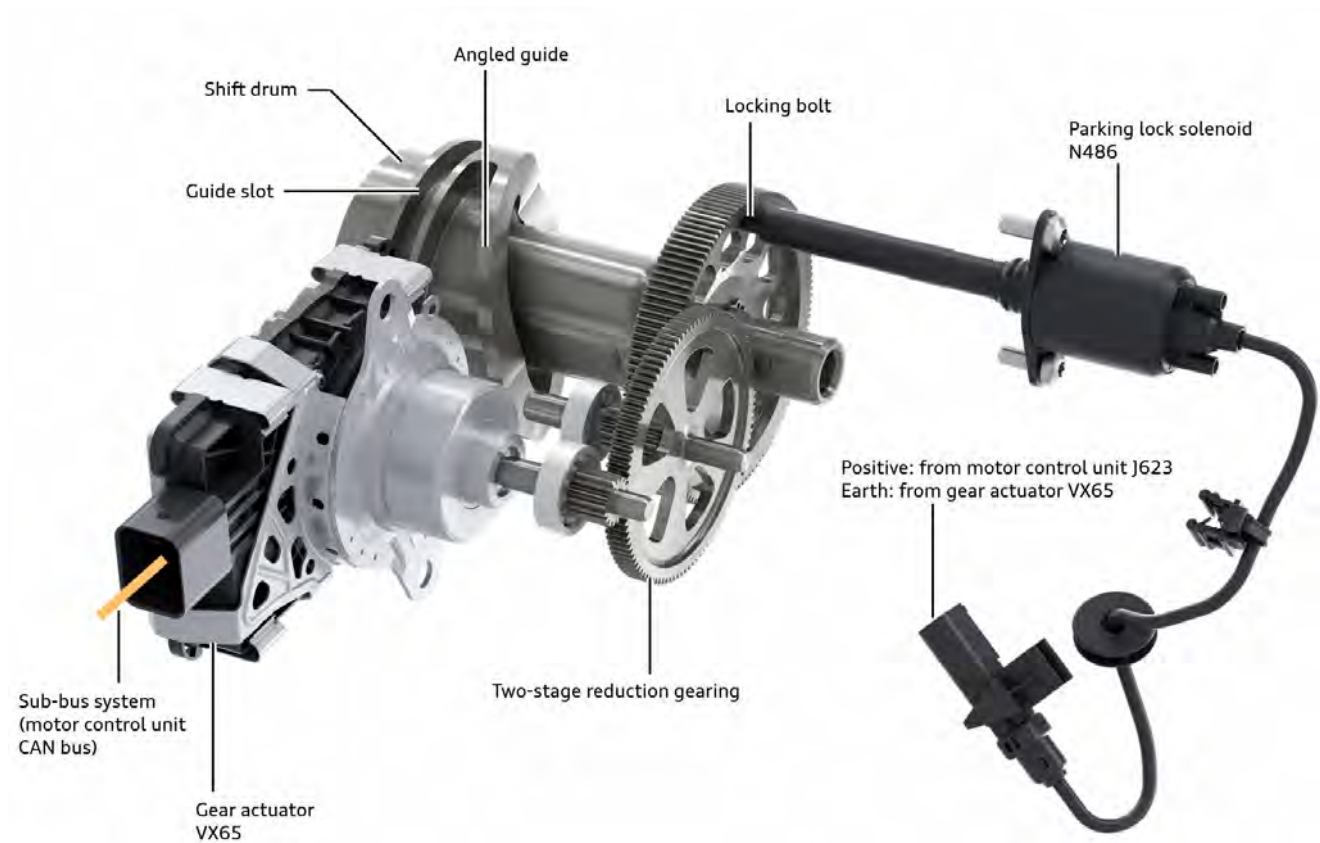

684_371

The dog clutch and the multi-plate clutch are actuated via the shift drum.

For this purpose, the shift drum has a guide groove for the selector fork of the dog clutch, and an angled guide for the release fork of the multi-plate clutch.

Gear actuator VX65 actuates the shift drum via a two-stage reduction gearing. This enables the gear actuator motor to apply the amount of force required for actuation.

Motor control unit J623 determines the appropriate gear based on the current operating status and activates gear actuator VX65 via a sub-bus system (motor control unit CAN bus).

Shift drum locking mechanism

When the vehicle is moving, it must not be possible for the parking lock function to be activated. There is a locking gate on the face of the toothed wheel for the shift drum for this purpose, (refer to image “684_372”). When the vehicle is driven, the locking pin of parking lock solenoid N486 protrudes into the locking gate and prevents the shift drum from turning to shift state A (P-ON).

If the vehicle comes to a halt, current flows to solenoid N486, which causes the locking pin to be pulled out of the slot. Now the shift drum can turn to shift state A (P-ON); the parking lock is then engaged.

Voltage is induced in the coil when the locking pin is pulled out of the slot. This voltage signal is evaluated as feedback and provides assurance that the locking pin has been removed from the locking gate.

When the sensors of the selector fork and release fork detect shift state A (P-ON), solenoid N486 can be switched off. Spring force causes the locking pin to extend; it lies against the end face of the gear wheel, removed from action.

Gear actuator VX65

It communicates with motor control unit J623 as a slave control unit via a sub-bus system (motor control unit CAN bus). As the gear actuator is involved in the immobiliser system, it is secured with anti-theft bolts. A special bit insert VAS 6970 is required to fit and tighten these bolts.

If the gear actuator or the transmission unit is renewed, the function “Work steps after component replacement” must be carried out using the vehicle diagnostic tester via address word 0001 “Engine electronics, functions”.



684_365



684_372

Shift drum positions and the resulting shift states

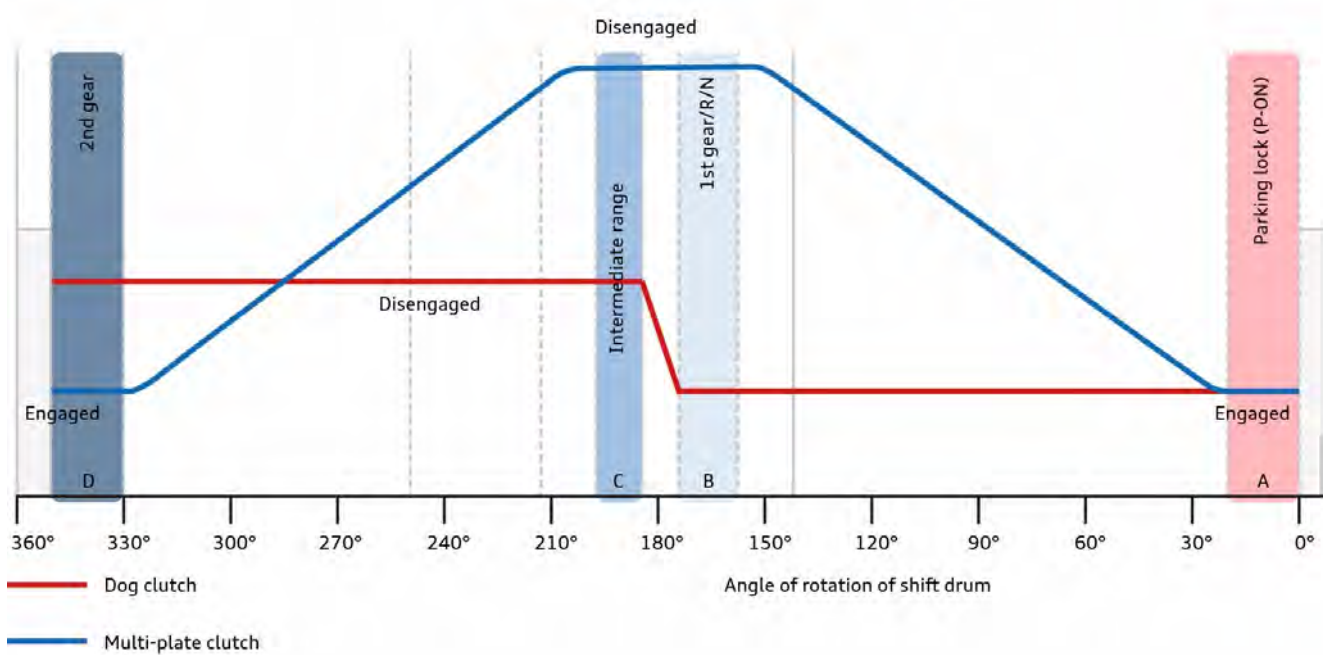

684_337

The motor control unit determines the desired gear/the desired shift state and delivers this information to gear actuator VX65. In doing so, it is influenced by the current Audi drive select mode, load requirement and speed (see shift programme).

Depending on the desired shift state, gear actuator VX65 turns the shift drum via the spur gear drive. The angle that the shift drum turns results in shift state A, B, C or D for the dog clutch/the multi-plate clutch.

When switching from state A to state D, the shift drum control logic requires going through states B and C.

Shift state A

The multi-plate clutch and the dog clutch are engaged. In conjunction with the locking effect of the freewheel, the entire transmission unit is blocked. Shift state A is applied for the parking lock function (see shift matrix).

In the case of a defective selector mechanism, the parking lock function can be disengaged using the diagnostic tester and the function 0001 Activation - release of parking lock. For this to be possible, the shift drum actuators must be intact, motor control unit J623 must be able to actuate gear actuator VX65, and the vehicle electrics must have sufficient power. There is no provision for mechanically releasing the parking lock function.

Shift state B

The multi-plate clutch is disengaged and the dog clutch is engaged. This shift state is applied in 1st gear, when recuperating in 1st gear, for reversing or for transmission position N (see shift matrix). Transmission position N is used to deactivate the parking lock function (P-OFF); it also makes it possible to push the vehicle and provides the car wash function.

Shift state C

This shift state constitutes the preparation for shifting into 2nd gear. If the multi-plate clutch is already disengaged, the first step is to disengage the dog clutch. This allows the sun gear of the planetary gear set to start rotating in the direction of the freewheel (it will overtake the freewheel) as the clutch closes.

State C is also shifted through when shifting from 2nd gear back into 1st gear. When the multi-plate clutch disengages, the planetary gear is no longer blocked. The planetary gears start to move and transmit power to the sun gear to provide the speed reduction for 1st gear. For this to happen, the sun gear must be held in locking direction by the freewheel; it is stationary.

Transition from shift state C to B

Before the dog clutch engages, it must be ensured that 1st gear is able to transmit power. This likewise ensures that the sun gear, and therefore the rotor of the dog clutch, is not moving and that it is already possible to engage the non-synchronised dog clutch during driving.

The dog clutch is engaged in order to recuperate in 1st gear and to enable driving in reverse gear.

Shift state D

The multi-plate clutch engaged and the dog clutch is disengaged. This shift state is applied in 2nd gear (see shift matrix).

Shift program

Audi drive select mode	Drive torque distribution	Driving off forwards	During driving	Shifting to speed reduction for 1st gear
efficiency	Front axle prioritised	2nd gear ^[4]	2nd gear	For reverse gear and in the case of special shifting behaviour
comfort	Economical four-wheel drive prioritised	2nd gear ^[4]	2nd gear	Yes, below approx. 50 km/h with high load requirement and for reverse gear
dynamic	Performance-oriented four-wheel drive	1st gear	2nd gear from approx. 70 - 110 km/h	Yes

The motor control unit selects the desired gear according to the Audi drive select mode, load requirement and vehicle speed.

The shift drum actuators apply the selected gear.

Audi drive select mode "efficiency"

The transmission unit remains exclusively in 2nd gear to provide maximum range. Only in transmission position R is the shift state for 1st gear applied to provide reverse gear.

Reverse gear is then applied by reversing the direction of rotation of the electric motor.

Audi drive select mode "comfort"

In comfort mode, the vehicle drives prioritises 2nd gear for driving off, and remains in 2nd gear. The vehicle only switches to 1st gear to provide maximum performance at speeds below approx. 50 km/h with a very high load requirement from the driver.

Audi drive select mode "dynamic"

In dynamic mode, the vehicle drives off in 1st gear. Depending on the load requirement, the vehicle shifts into 2nd gear starting from speeds between approx. 70 km/h and 110 km/h. As a rule, the vehicle shifts back into 1st gear if the driving speed falls below this range. The exact speed at which the downshift occurs depends on how the vehicle is being driven.

Special shifting behaviour

When the vehicle is driven in transmission position D, 2nd gear is normally used for driving off. If position R is selected and then position D, 1st gear remains selected initially. Only after reaching a driving speed above approx. 20 km/h does the vehicle shift into 2nd gear.

[4] Driving off in 1st gear is also possible; see "special shifting behaviour"

Transmission schematic

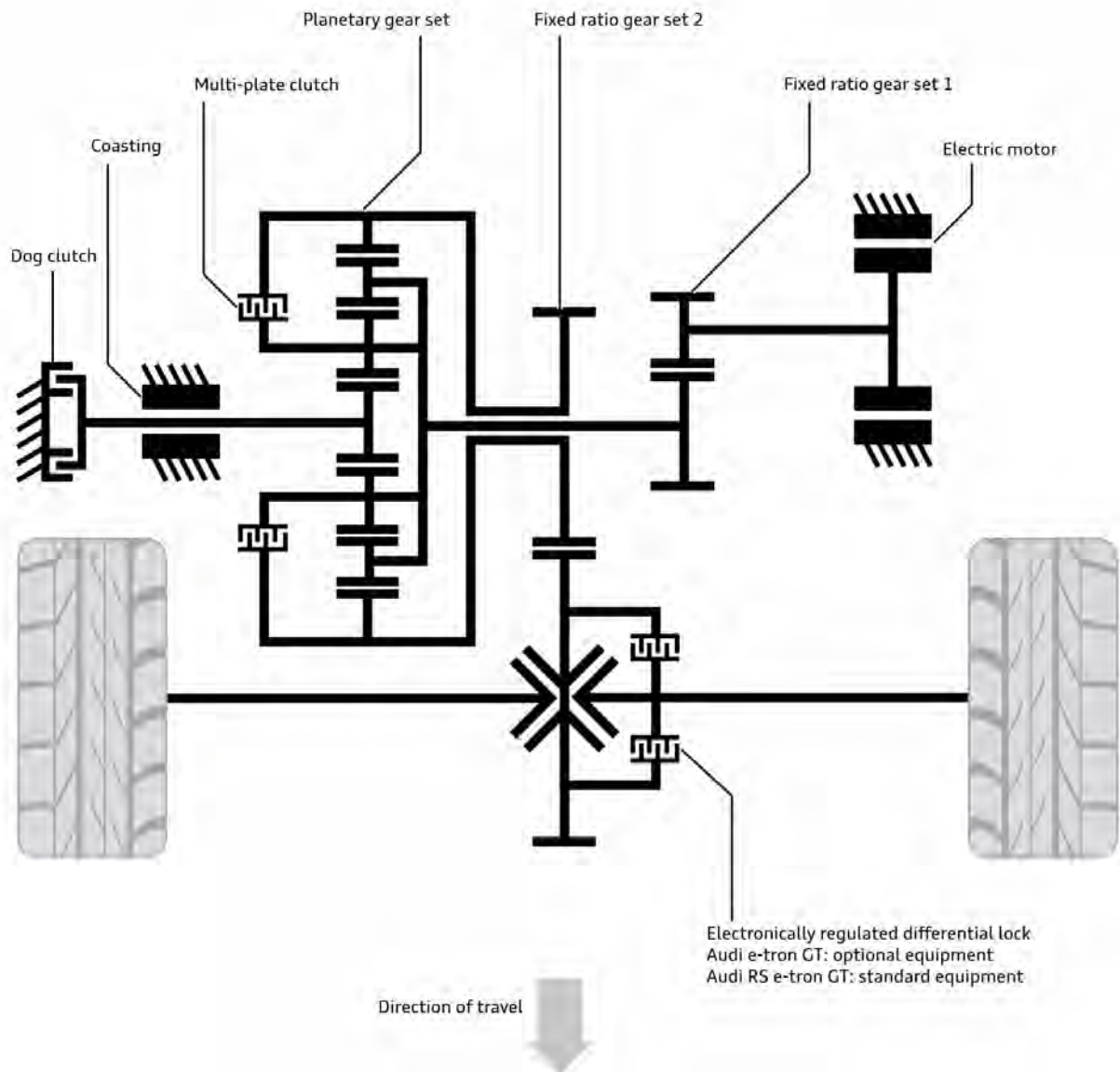

684_179

The gearbox schematic shows the gearbox when the vehicle is stationary and in transmission position N.

Shift matrix

	Transmission position/gear	Dog clutch	Multi-plate clutch	Free-wheel	Remarks
Drive	R	Engaged (pre-loaded)	Disengaged (actuated)		Reverse gear is applied by reversing the direction of rotation of the electric motors. The planetary gear set of two-speed transmission OME acts as a speed reduction stage in the same way as for 1st gear. The torque is transferred via the sun gear which is blocked by the dog clutch.
	N	Engaged (untensioned)	Disengaged (actuated)		The transmission unit does not have a neutral position, i.e. there is no shift position in which the power flow between the electric drive motor and the wheels is interrupted. Transmission position N corresponds to the shift position for 1st gear and reverse gear.
	P	Engaged (pre-loaded when rolling forwards)	Engaged (not actuated)	Blocked (when rolling backwards)	The transmission unit does not have a physical parking lock. By blocking the entire planetary gear set (annulus with planet carrier and sun gear in both directions), the gearbox is blocked; this serves as the parking lock function.
	D1	Closed (untensioned)	Disengaged (actuated)	Blocked	The planetary gear set serves as a speed reduction stage. The torque is transferred via the sun gear which is blocked by the free-wheel.
	D2	Open	Engaged (not actuated)	Freewheel	The planetary gear set is blocked. Annulus, sun gear and planet carrier rotate at the same speed.
Recuperation	D1	Closed (pre-loaded)	Disengaged (actuated)		The planetary gear set serves as a speed reduction stage. The direction of power flow is reversed. The torque is transferred via the sun gear which is blocked by the dog clutch.
	D2	Open	Engaged (not actuated)	Freewheel	The planetary gear set is blocked. Annulus, sun gear and planet carrier rotate at the same speed. The direction of power flow is reversed without affecting the free-wheel.

Power flow

Single-speed, D1, transmission

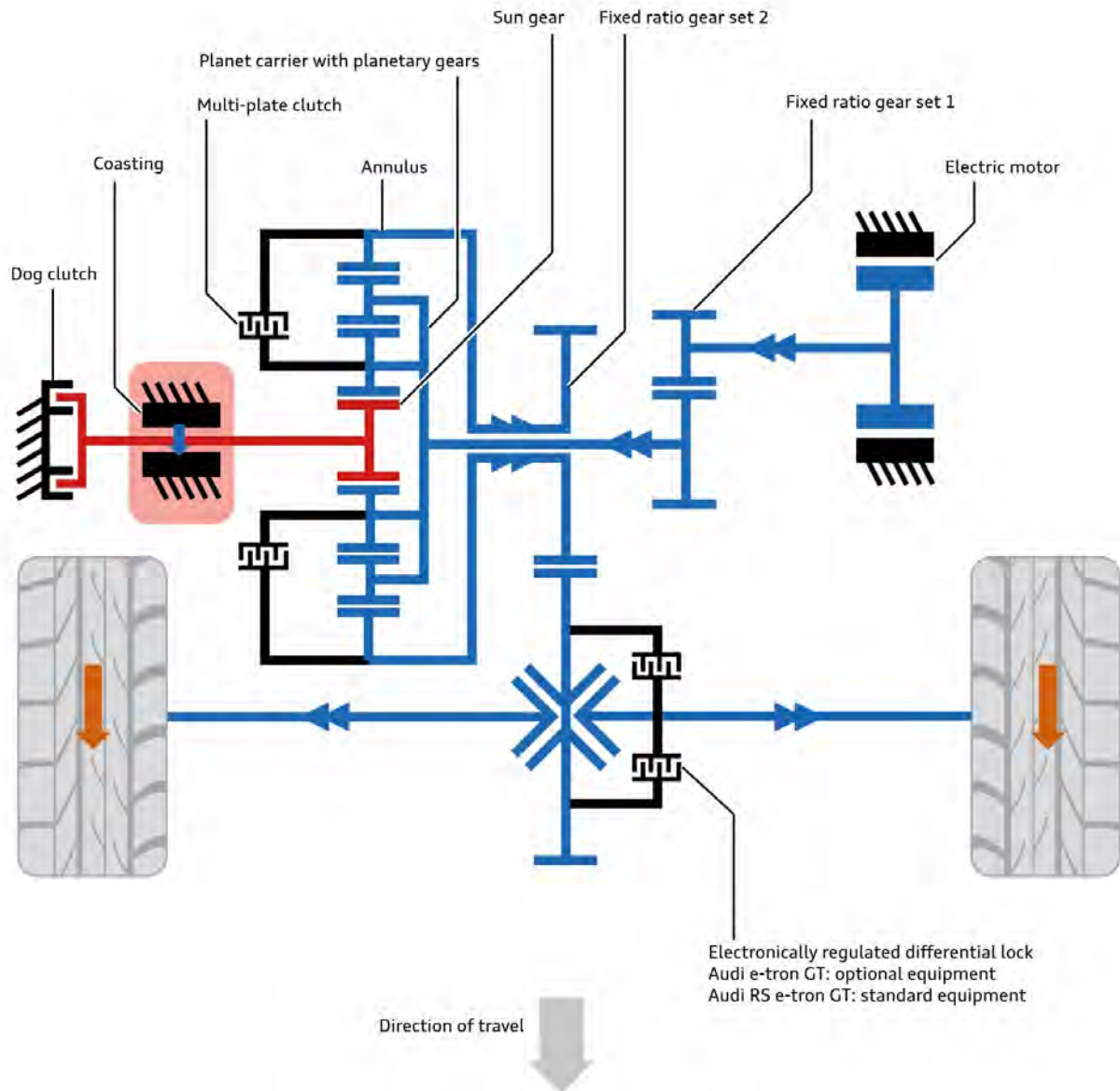

684_200

Key:

- █ Torque curve/power flow
- █ Blocked, stationary components
- █ Parts which co-rotate without being involved in power flow
- █ Engaged, blocked, engaged for power transmission
- Components joined to housing
- Clutch
- Power flow arrow

Transmission position/gear	Dog clutch	Multi-plate clutch	Freewheel	Remarks
Drive D1	Closed (untensioned)	Disengaged (actuated)	Blocked	The planetary gear set serves as a speed reduction stage. The torque is transferred via the sun gear which is blocked by the freewheel.

Single-speed, D1, recuperation

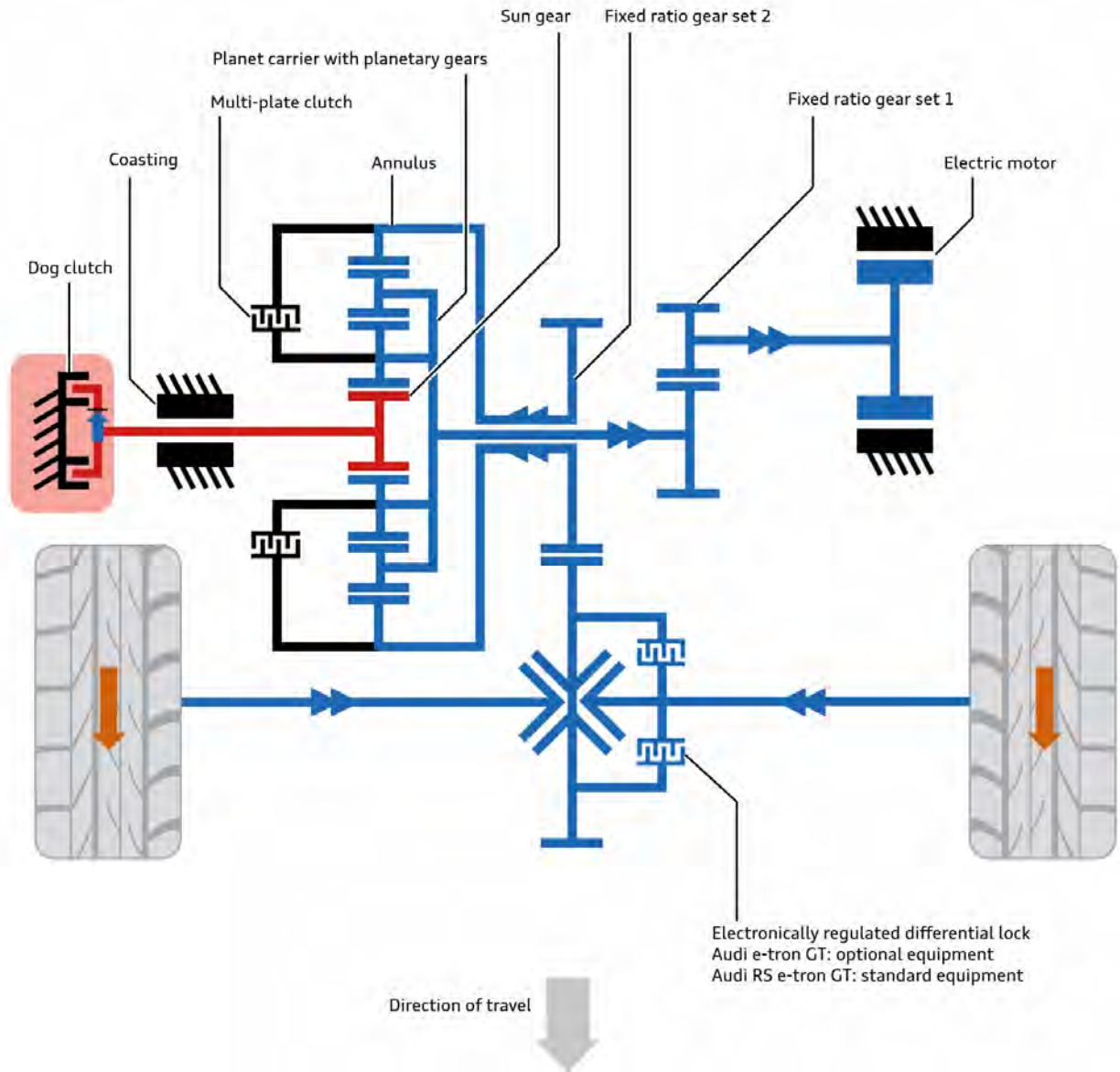

684_180

Key:

- █ Torque curve/power flow
- █ Blocked, stationary components
- Parts which co-rotate without being involved in power flow
- Engaged, blocked, engaged for power transmission
- Components joined to housing
- Clutch
- ➔ Power flow arrow

Transmission position/gear	Dog clutch	Multi-plate clutch	Free-wheel	Remarks
Recuperation D1	Closed (pre-loaded)	Disengaged (actuated)		The planetary gear set serves as a speed reduction stage. The direction of power flow is reversed. The torque is transferred via the sun gear which is blocked by the dog clutch.

Reversing in 1st gear

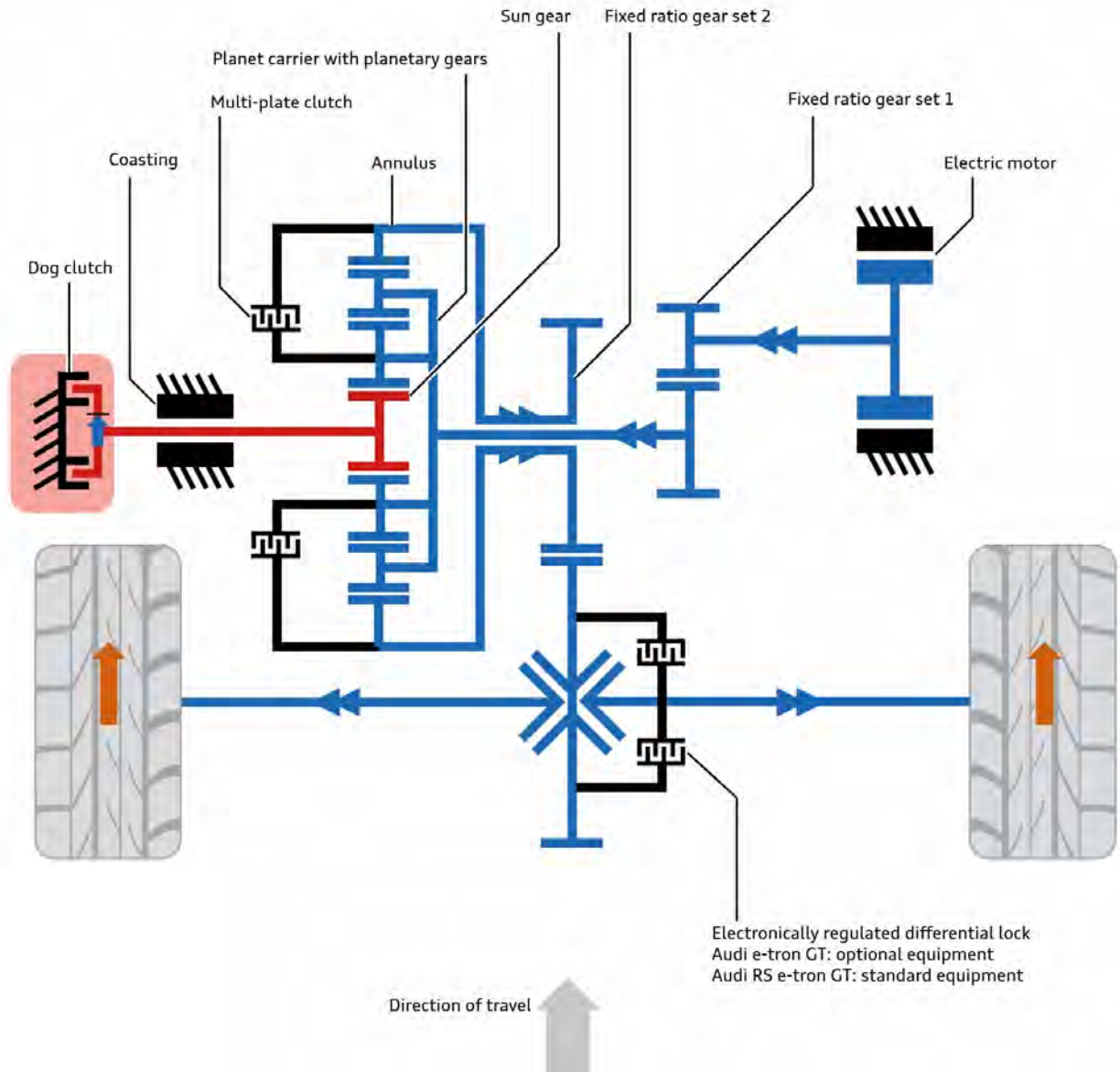

684_201

Key:

- █ Torque curve/power flow
- █ Blocked, stationary components
- █ Parts which co-rotate without being involved in power flow
- █ Engaged, blocked, engaged for power transmission
- Components joined to housing
- Clutch
- Power flow arrow

Transmission position/gear	Dog clutch	Multi-plate clutch	Free-wheel	Remarks
Drive R	Engaged (pre-loaded)	Disengaged (actuated)		Reverse gear is applied by reversing the direction of rotation of the electric motors. The planetary gear set of two-speed transmission OME acts as a speed reduction stage in the same way as for 1st gear. The torque is transferred via the sun gear which is blocked by the dog clutch.



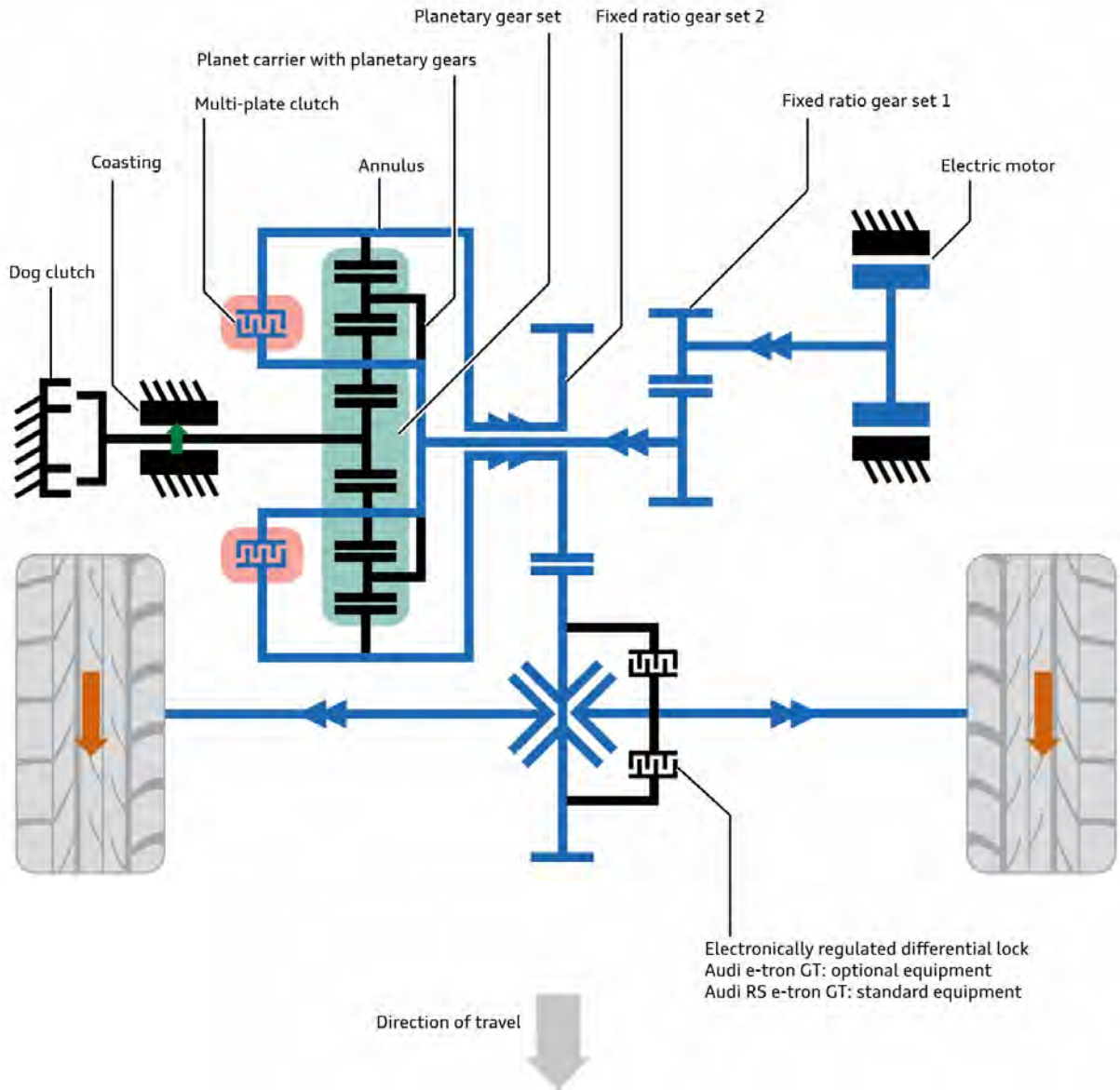





2-speed, D2



Electronically regulated differential lock
 Audi e-tron GT: optional equipment
 Audi RS e-tron GT: standard equipment

684_202

Key:

-  Torque curve/power flow
-  Blocked, stationary components
-  Parts which co-rotate without being involved in power flow
-  Engaged, blocked, engaged for power transmission
-  Components joined to housing
-  Clutch
-  Power flow arrow
-  Planetary gear set in blocking mode/blocked

	Transmission position/gear	Dog clutch	Multi-plate clutch	Freewheel	Remarks
Drive	D2	Open	Engaged (not actuated)	Freewheel	The planetary gear set is blocked. Annulus, sun gear and planet carrier rotate at the same speed.
Recuperation	D2	Open	Engaged (not actuated)	Freewheel	The planetary gear set is blocked. Annulus, sun gear and planet carrier rotate at the same speed. The direction of power flow is reversed without affecting the freewheel.

As the planetary gear set is blocked by the multi-plate clutch, the torque is transmitted directly from the planet carrier to the annulus. The planetary gears and the sun gear do not affect the drive torque or the overrun torque during recuperation.

The reversed direction of power flow during recuperation does not affect the freewheel.

Transmission position P

Parking lock function when rolling forwards

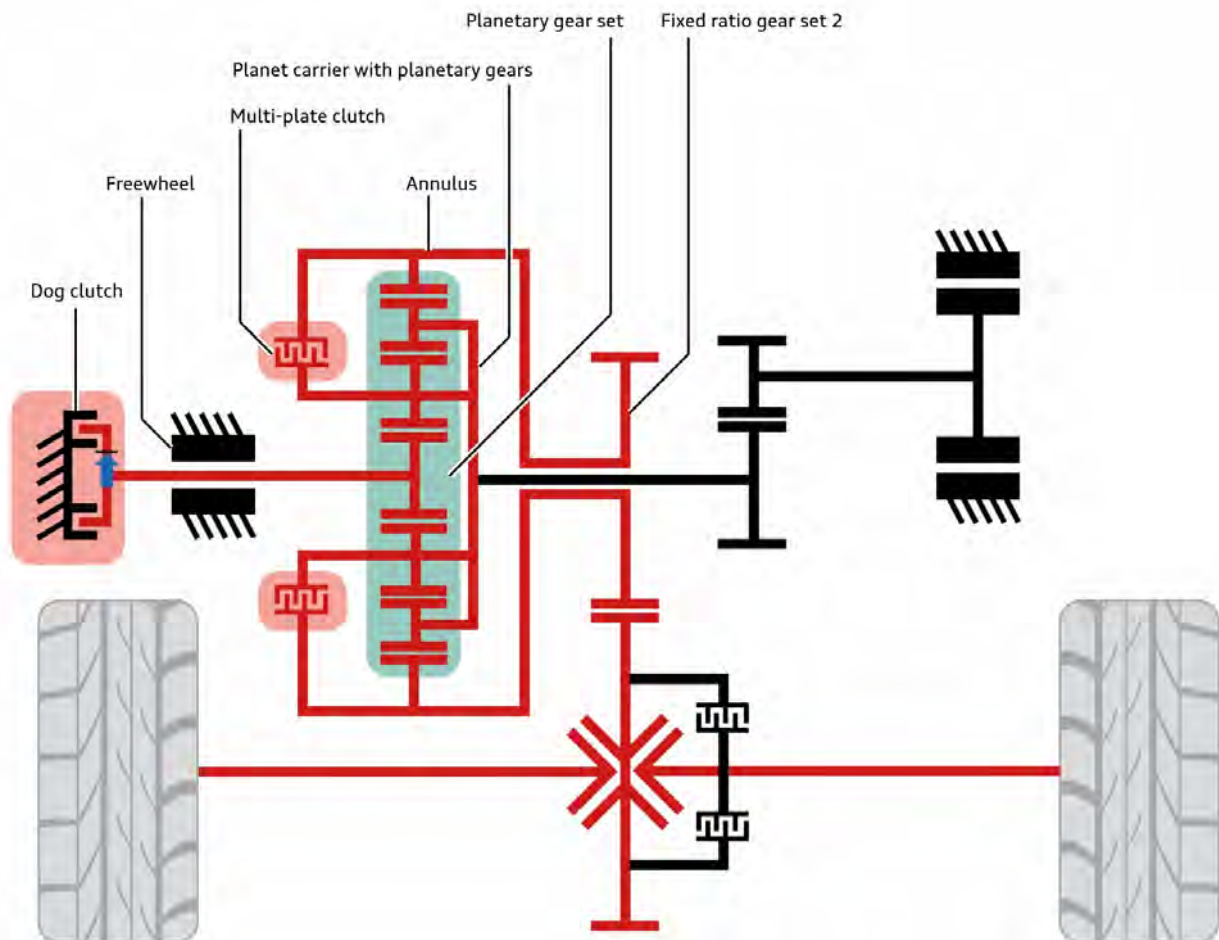

684_203

Transmission position/gear	Dog clutch	Multi-plate clutch	Freewheel	Remarks
P	Engaged (pre-loaded when rolling forwards)	Engaged (not actuated)	Blocked (when rolling backwards)	The transmission unit does not have a physical parking lock. By blocking the entire planetary gear set (annulus with planet carrier and sun gear in both directions), the gearbox is blocked; this serves as the parking lock function.

Parking lock function when rolling backwards

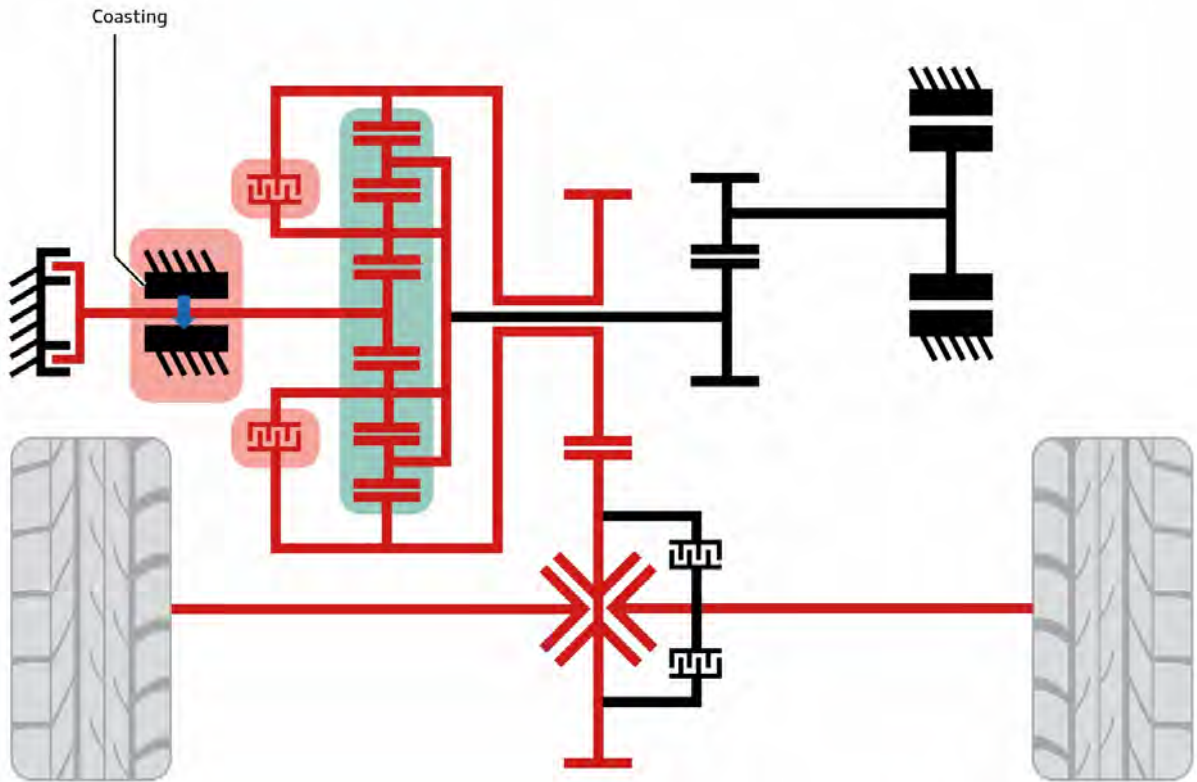

684_204







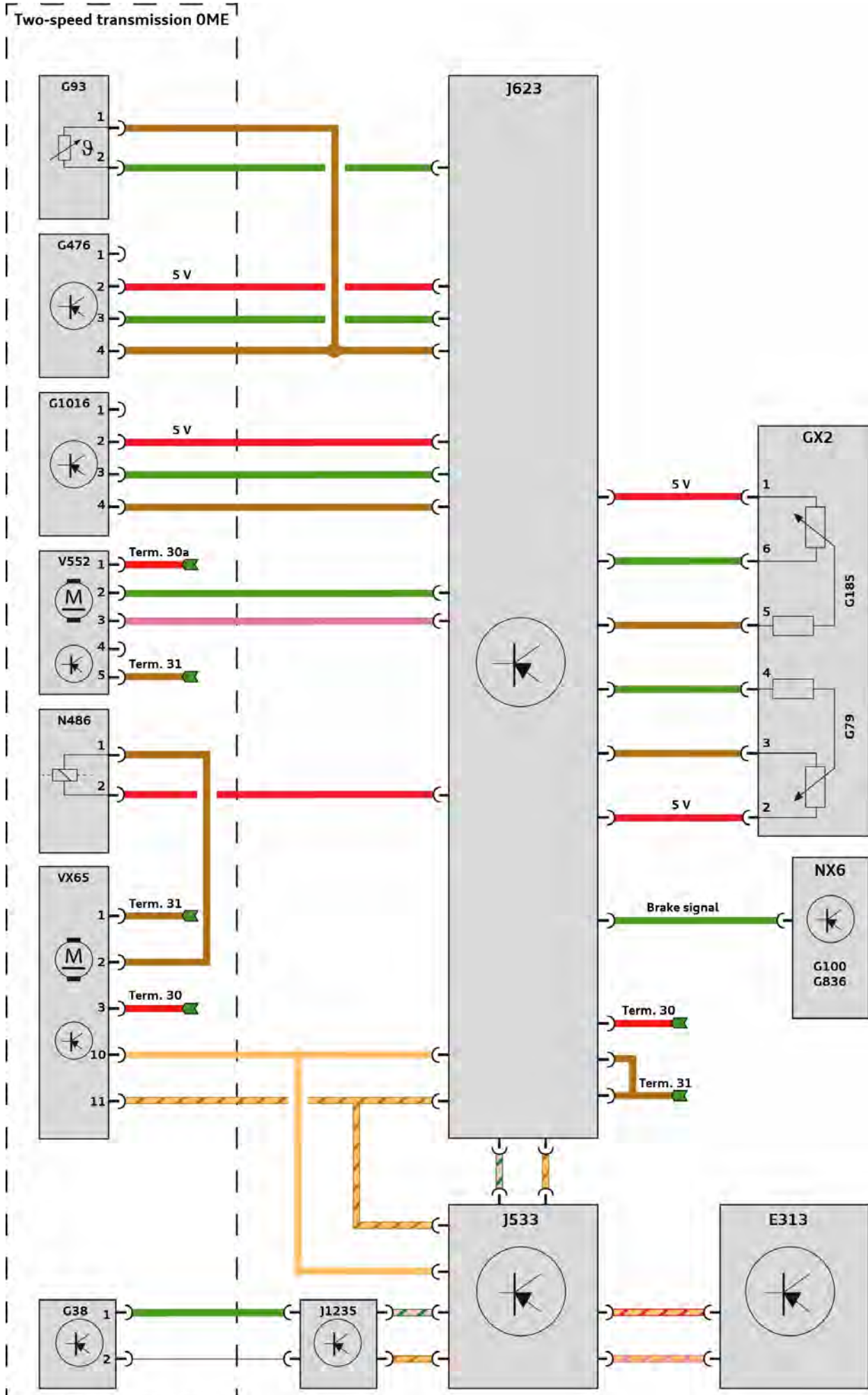



Key:

- Torque curve/power flow
- Blocked, stationary components
- Parts which co-rotate without being involved in power flow
- Engaged, blocked, engaged for power transmission
- Components joined to housing
- Clutch
- Power flow arrow
- Planetary gear set in blocking mode/blocked

Function diagram, 2-speed transmission OME



Key:

E313	Selector lever
G38	Gearbox speed sender
G79	Accelerator position sender
G93	Gearbox oil temperature sender
G100	Brake pedal position sender
G185	Accelerator position sender 2
G476	Clutch position sender
G836	Brake pedal position sender 2
G1016	Clutch jaw position sensor
GX2	Accelerator pedal module
J533	Data bus diagnostic interface
J623	Engine control unit
J1235	Electric drive control unit for rear axle
N486	Parking lock solenoid
NX6	Brake servo
V552	Gearbox auxiliary hydraulic pump
VX65	Gear actuator
	Earth wire
	Positive wire
	LIN bus
	Sensor wire
	FlexRay
	FlexRay Low
	Sub-bus system (motor control unit CAN bus) High
	Sub-bus system (motor control unit CAN bus) Low
	CAN bus High (Infotainment)
	CAN bus Low (Infotainment)

Sensors

Clutch position sender G476

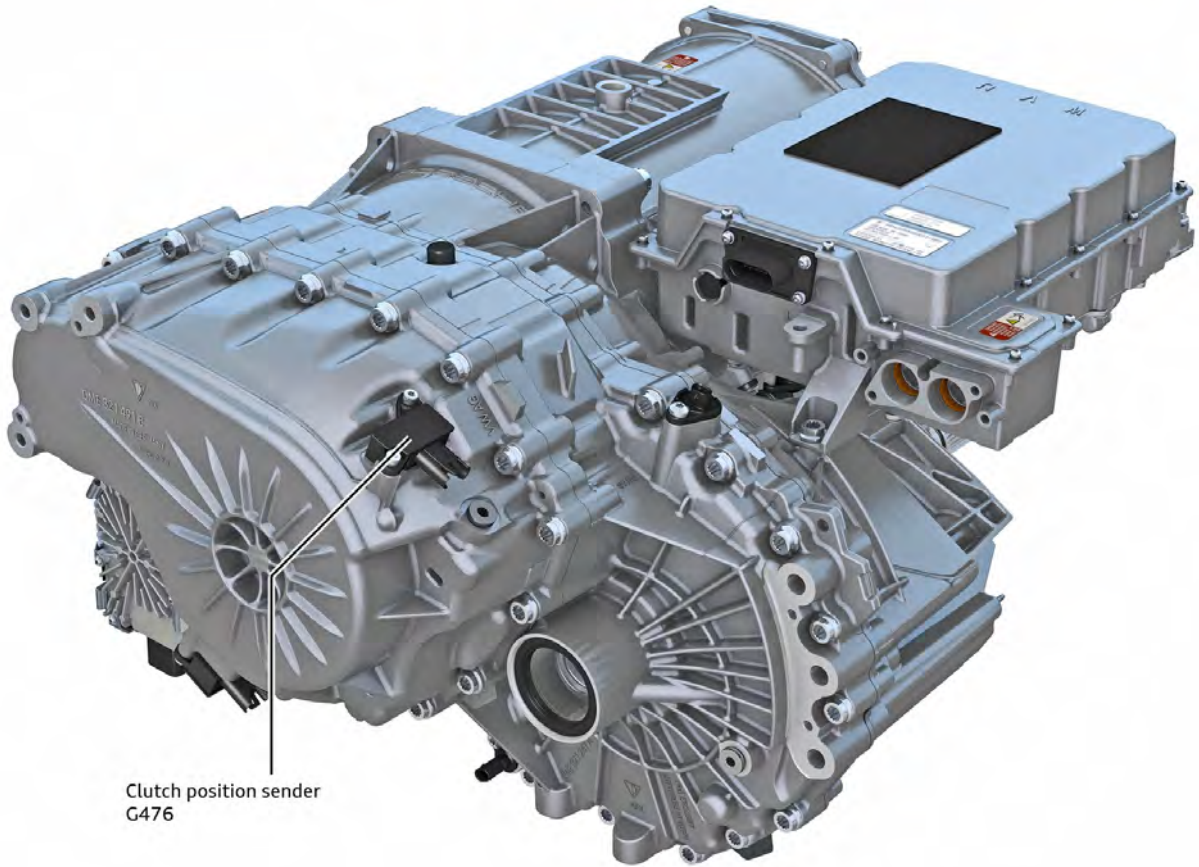

Clutch position sender
G476

684_175

Clutch position sender G476 helps register the shift state of the multi-plate clutch. It is bolted onto the gearbox housing from the outside. If repairs are required, only the bolts listed in the electronic parts catalogue (ETKA) for this purpose may be used.

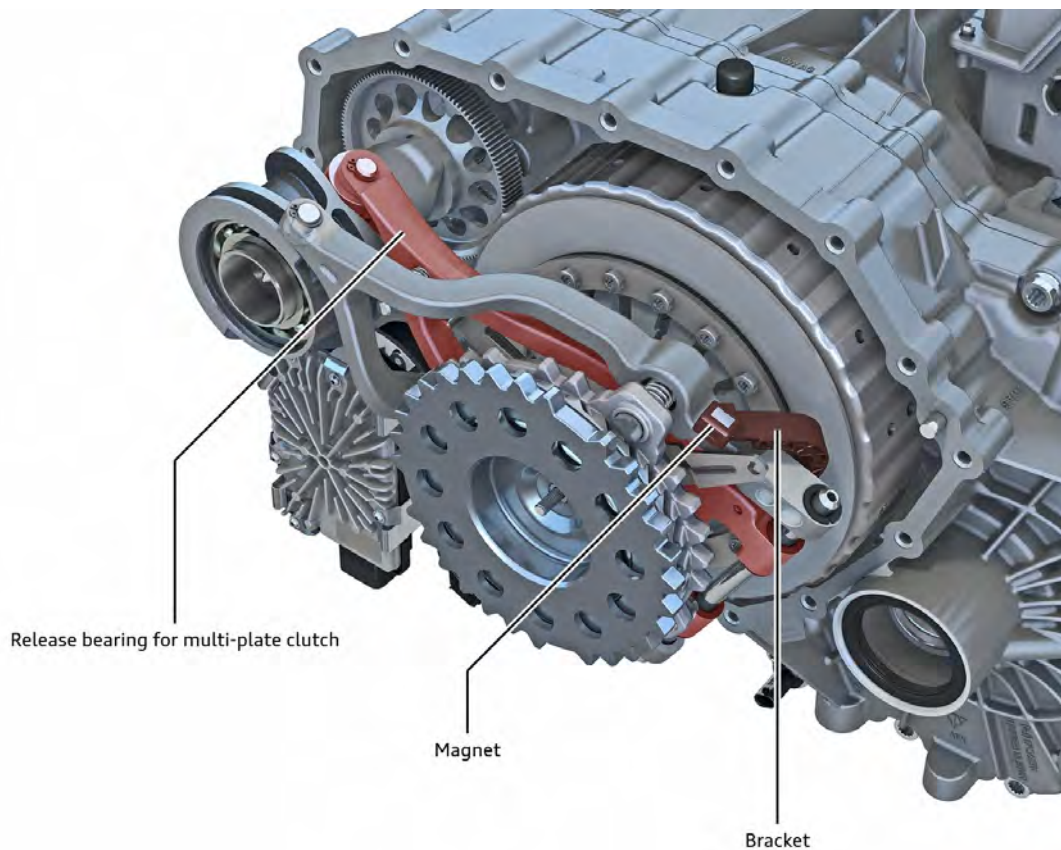

684_437

The shift state of the multi-plate clutch is registered indirectly based on the position of the release fork. The release fork is fitted with a bracket on which a small magnet is secured. This is used to register the position of the release fork. When the position of the release fork changes, the magnet moves along below clutch position sender G476.

Clutch position sender G467 is supplied with current (approx. 5 V) by motor control unit J623. It registers the movement of the magnet and uses it to generate a PWM signal^[5]. Using this signal, the motor control unit determines the shift state of the multi-plate clutch.

The information regarding the shift state of the multi-plate clutch is also used to determine the state of the parking lock function (P-ON/P-OFF).

If clutch position sender G476 fails, no gear changes take place during driving.

If clutch position sender G476 is renewed, the function "Work steps after component replacement" must be carried out using the vehicle diagnostic tester via address word 0001 "Engine electronics, functions".

[5] PWM = pulse-width modulation

Sensor concept

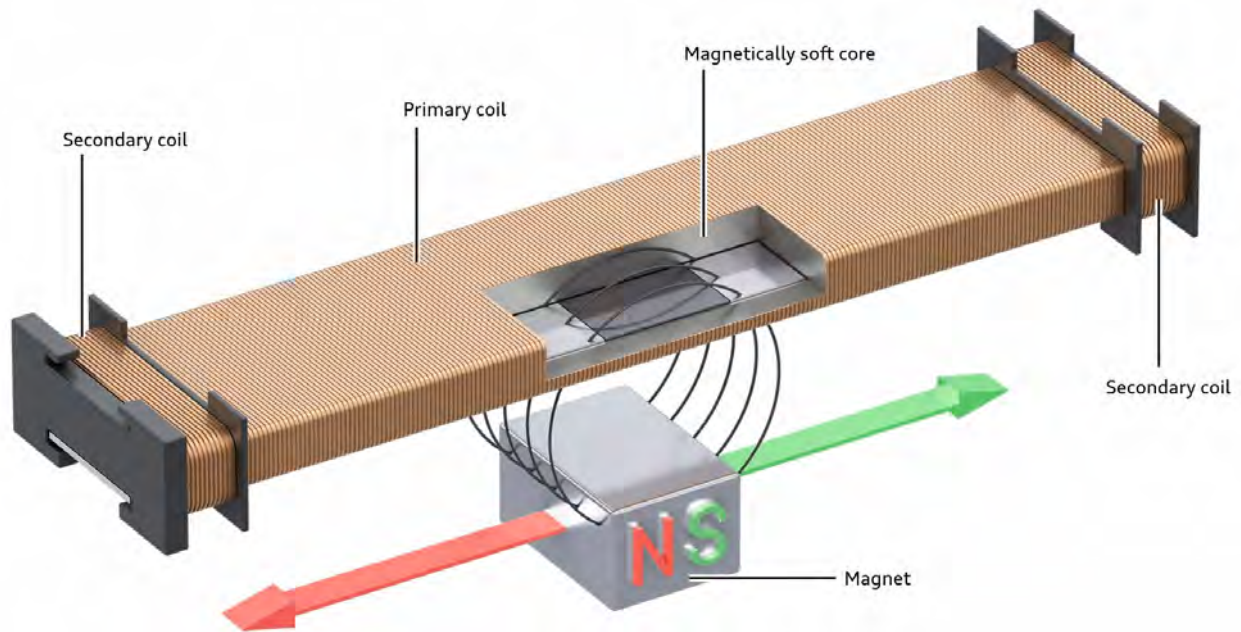

684_340

Clutch position sender G476 works like a differential transformer. The centre part of the magnetically soft core is wrapped with a primary coil. The core has a secondary coil at each end which is wound in the opposite direction. The primary coil is supplied with alternating voltage, and thereby also induces alternating voltage in the secondary coil.

When the magnet is in the centre of the sensor, the induced voltages in the secondary coils (wound in the opposite direction) cancel each other out. If the magnet is pushed out of the centre, a difference in voltage arises at the secondary coils. The sensor electronics use this to generate a PWM signal that corresponds to the position of the magnet.



Reference

For further information on this sensor concept, please refer to SSP 241 "The Audi allroad quattro with additional shift stage", starting on page 56.

Clutch jaw position sensor G1016

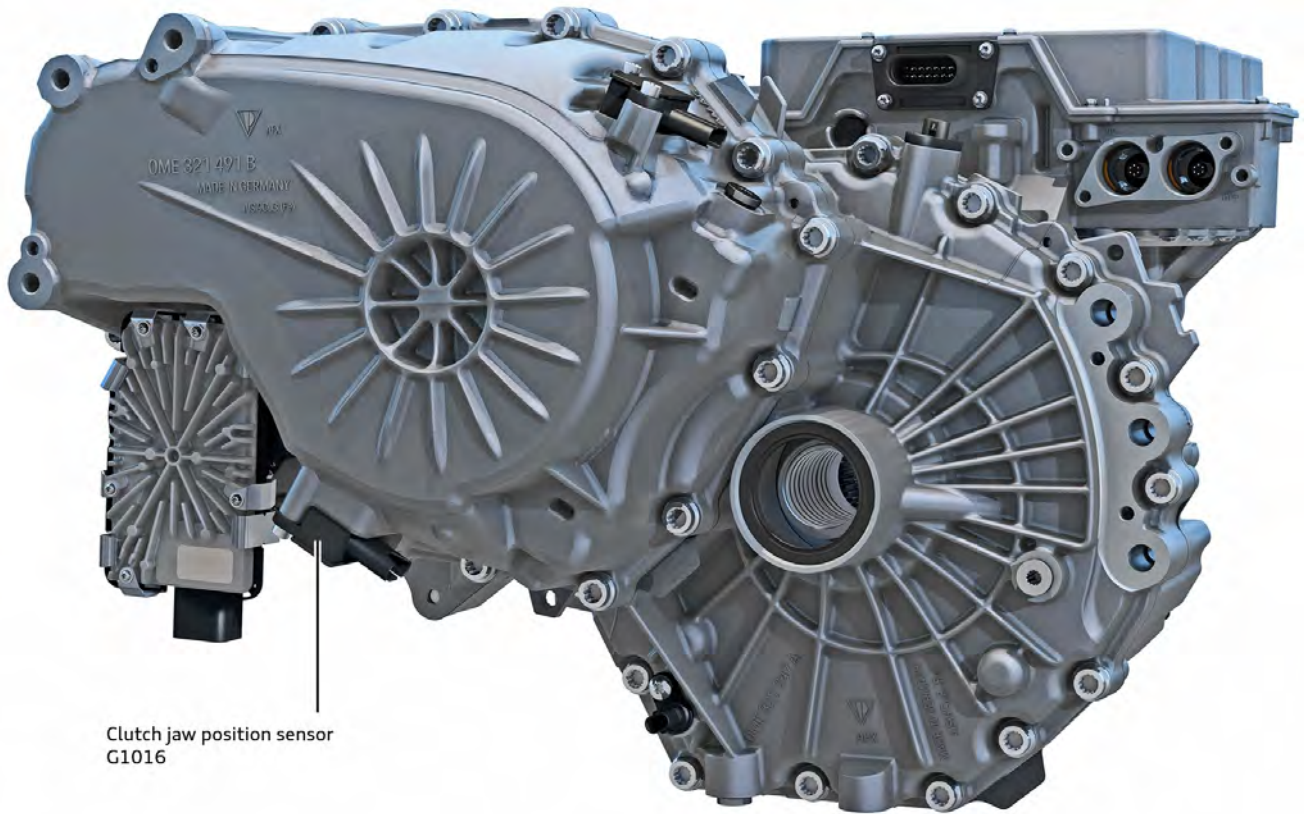

684_328

Clutch jaw position sensor G1016 registers the shift position of the dog clutch. It is bolted onto the gearbox housing from the outside. If repairs are required, only the bolts listed in the electronic parts catalogue (ETKA) for this purpose may be used.

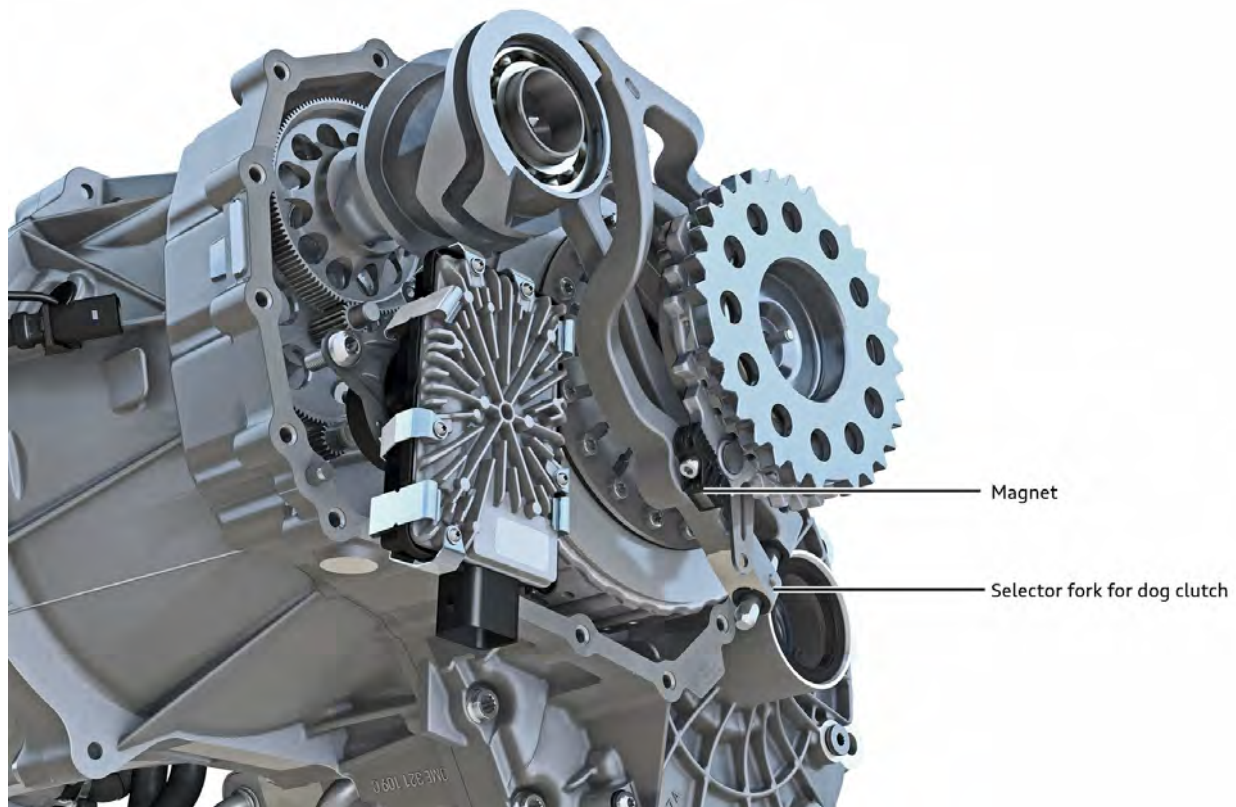

684_327

The position of the stator of the dog clutch is used to determine the shift state of the dog clutch. A small magnet is fitted on the stator for this purpose. When the position of the stator changes, the magnet moves along below clutch jaw position sensor G1016.

Sensor G1016 is supplied with current (approx. 5 V) by motor control unit J623. It registers the movement of the magnet and uses it to generate a PWM signal^[5]. Using this signal, the motor control unit determines the shift state of the dog clutch.

The information regarding the shift state of the dog clutch is also used to determine the state of the parking lock function (P-ON/P-OFF).

If clutch jaw position sensor G1016 fails, no gear changes take place during driving. If clutch jaw position sensor G1016 is renewed, the function “Work steps after component replacement” must be carried out using the vehicle diagnostic tester via address word 0001 “Engine electronics, functions”.

Sensor concept

Clutch jaw position sensor G1016 works in the same way as clutch position sender G476.

Gearbox oil temperature sender G93

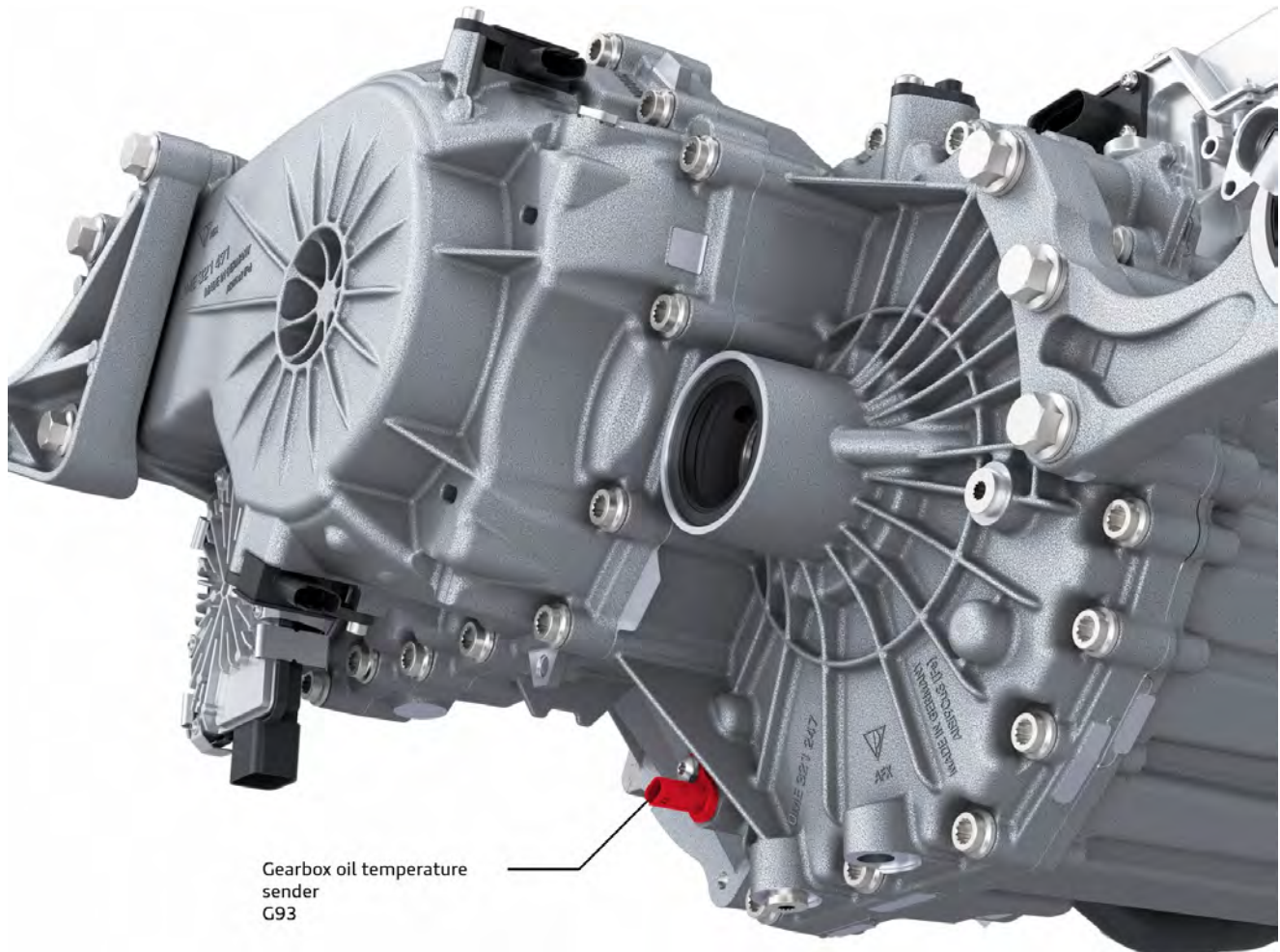

684_353

Gearbox oil temperature sender G93 measures the gear oil temperature in the oil pan and sends this information to motor control unit J623. The gear oil temperature measured is used to deduce the temperature of the multi-plate clutch.

To ensure that the multi-plate clutch is cooled sufficiently, the delivery volume from the electric gear oil pump is varied accordingly.

The table lists the measures that are carried out and the messages that are shown in the instrument cluster to protect the components and the gear oil at oil temperatures above approx. 110 °C.



If sender G93 fails due to a defect, the delivery rate of gearbox auxiliary hydraulic pump V552 is increased accordingly, and the torque of the electric drive motor is reduced. In addition, the launch control function is not available.

The instrument cluster shows the yellow warning lamp and the message:



Gearbox malfunction: you can continue driving

[5] PWM = pulse-width modulation

Oil temperature Measure		Displays/messages
> 110 °C	Torque of electric drive motor reduced. Launch control not available.	 Gearbox overheating: please adapt driving style.
> 120 °C	Additionally, forced shift into 2nd gear with downshifting prohibited.	 Gearbox overheating: please adapt driving style.
> 130 °C	Maximum speed reduced additionally.	 Gearbox overheating: please stop vehicle

Gearbox speed sender G38

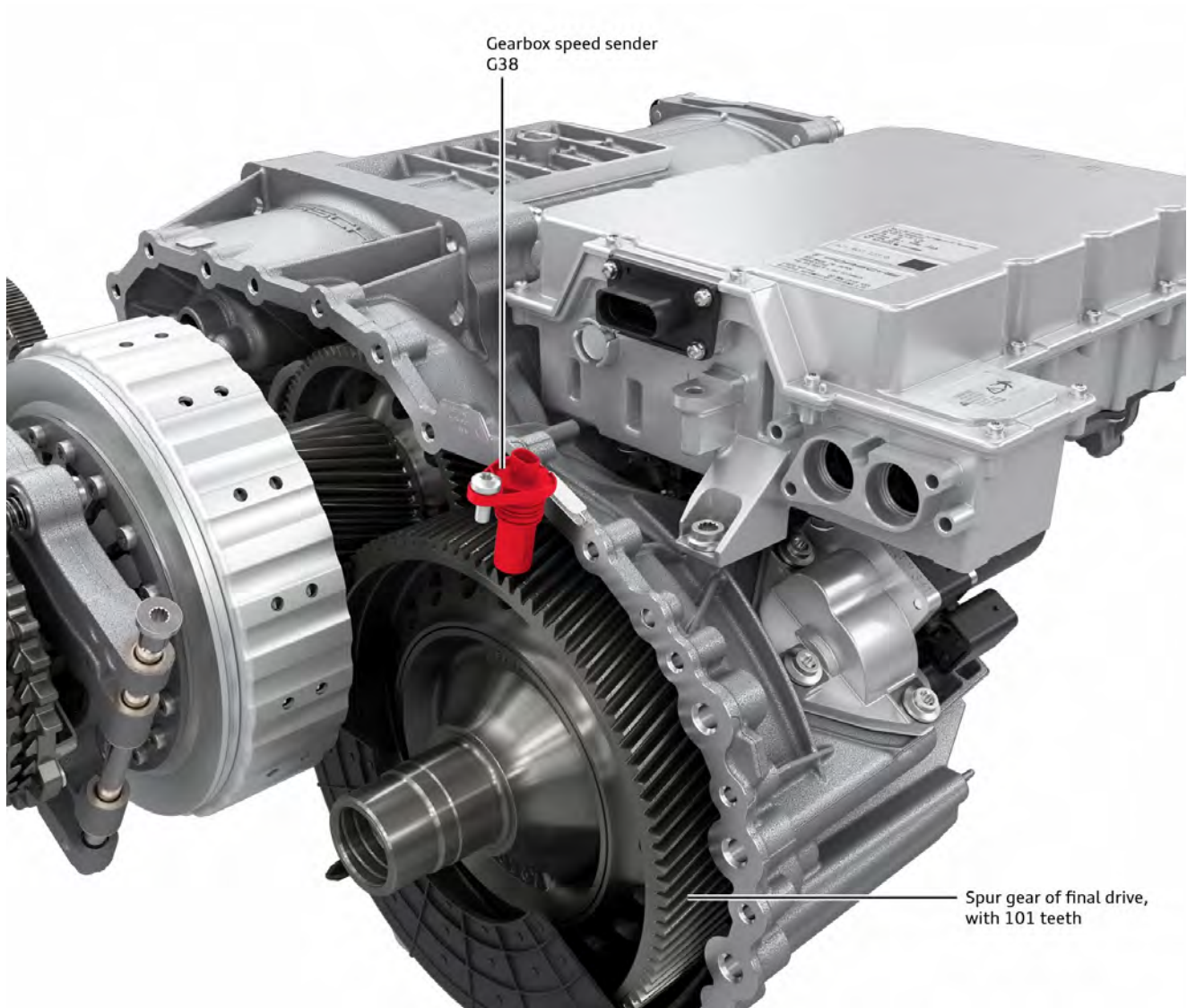

684_352

Gearbox speed sender G38 helps the power electronics J1235 determine the following information:

- > Gearbox output speed
- > Direction of travel
- > Slip in multi-plate clutch
- > Target speed for gear change

Speed sender G38 is composed of three Hall elements arranged in series, a permanent magnet and sensor electronics to generate a square wave signal. The large spur gear of the final drive acts as the sender wheel.

The sender is supplied with a 5-Volt current by the power electronics J1235. The sensor electronics use the signals from the individual Hall elements to determine the speed and direction of rotation of the gear wheel.

The direction of rotation of the gear wheel is indicated by the duration of the square-wave signal.

- > The signal duration when driving forwards is 120 μ s
- > The signal duration when reversing is 60 μ s

The speed of the gear wheel (proportional to the vehicle speed) is indicated on the basis of the frequency (f) with which the square-wave signal occurs. The frequency corresponds to the inverse value of the cycle duration (T).

$$f = \frac{1}{T} \left[\frac{1}{s} = 1 \text{ Hz} \right]$$

At frequencies of 1000 Hz and above (which corresponds to a vehicle speed of approx. 75 km/h), the cycle duration is reduced to 30 μs as a general rule.

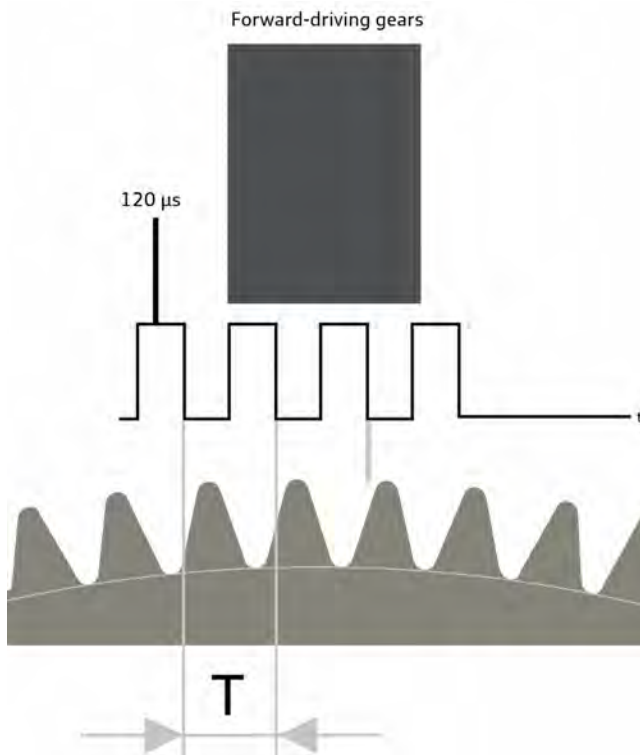

684_421

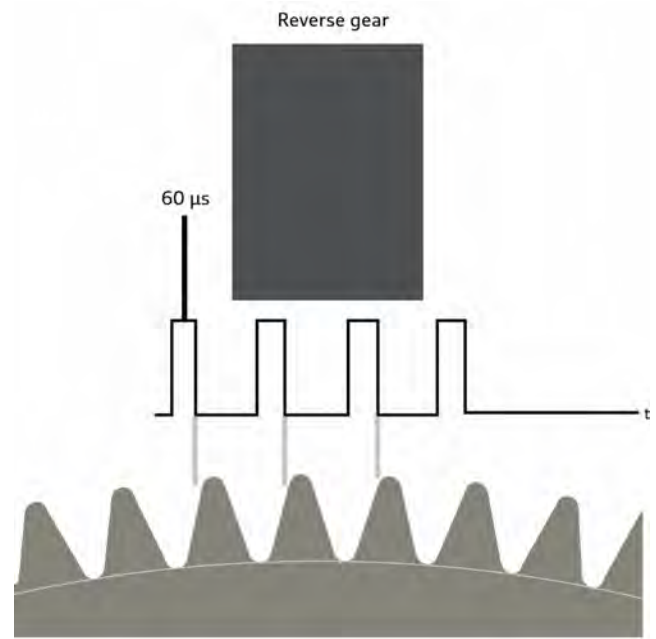

684_360

Measures if there is slip in the multi-plate clutch



Motor control unit J623 receives information on the speed of the electric drive motor and the gearbox output speed of the power electronics J1235. It uses these two speeds to calculate the slip in the multi-plate clutch.

The table lists the measures that are carried out and the messages that are shown in the instrument cluster if there is slip in the multi-plate clutch that should not be present (depending on the amount of slip):

As the parking lock function is carried out in part by the multi-plate clutch, this function may not be available if there is too much slip in the clutch. If there is slip in the clutch, the transmission unit can no longer be used reliably to prevent the vehicle from rolling away.

When the vehicle is stationary, the warning message **Vehicle may roll away! P cannot be selected. Please apply parking** appears in the instrument cluster, and the yellow warning lamp lights up.

The vehicle can then be prevented from rolling away only by applying the parking brake.

Clutch slip Measure		Displays/messages
Sporadic	Torque of electric drive motor reduced.	 Gearbox malfunction: you can continue driving
Constant	Torque of electric drive motor reduced. Additionally: Forced shift back into 1st gear and therefore reduced maximum speed; upshifting prohibited.	 Gearbox malfunction: you can continue driving
	No parking lock function.	 Vehicle may roll away! P cannot be selected. Please apply parking brake

Oil system

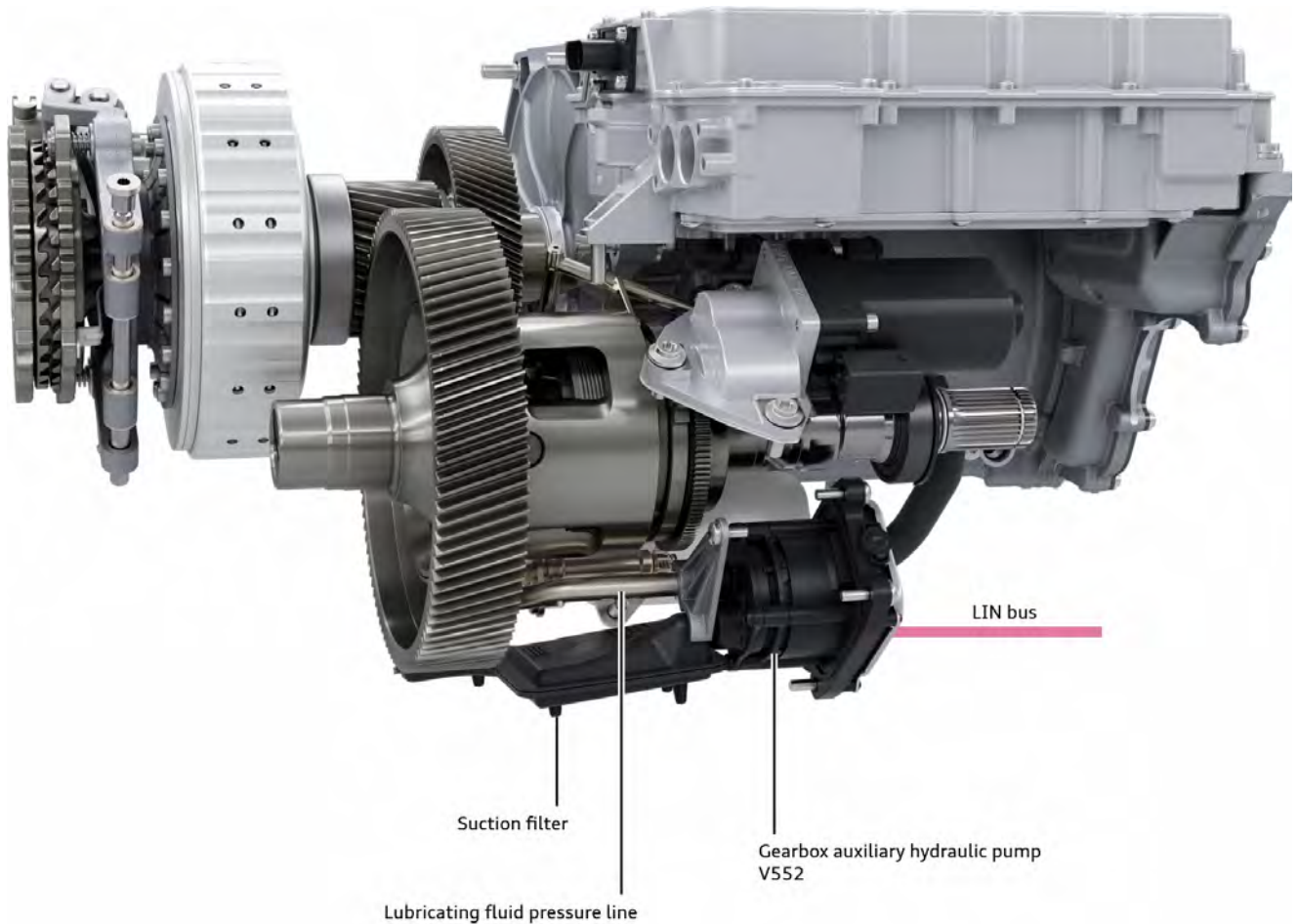

684_354

Gearbox auxiliary hydraulic pump V552

Gearbox auxiliary hydraulic pump V552 supplies the transmission with lubricating/cooling oil as required. The oil pump draws gear oil out of the oil pan via the suction filter and conveys the oil to all areas requiring lubrication via oil pressure lines and oil passages in the transmission housing.

The pump consists of a brushless DC motor that drives an annular gear pump, as well as integrated power electronics. Motor control unit J623 evaluates the amount of lubrication and cooling required for the current operating state, and uses this to determine the required pump speed.

The information exchanged between motor control unit J623 and the oil pump is transmitted via a separate LIN bus.



After the drive system is activated, the oil pump is actuated briefly to lubricate all the components. If the vehicle remains stationary, the oil pump is actuated briefly approx. every 20 seconds, irrespective of the transmission position currently selected.

As soon as the vehicle is driven, motor control unit J623 actuates the oil pump as necessary. The pump speed is regulated according to the following parameters:

- > The calculated input torque of the transmission,
- > The gearbox output speed,
- > The selected gear,
- > The oil pan temperature,
- > The lateral/longitudinal acceleration of the vehicle

Oil pump V552 sends a speed signal back to motor control unit J623 in a closed feedback loop. This allows the motor control unit to re-adjust the pump speed if necessary and ensure that the required amount of lubrication/cooling for the transmission is provided.

If the pump speed drops when it should not, or if the pump fails, the following measure are taken:

Cause	Measure	Displays/messages
Slight drop in pump speed, e.g. oil filter dirty	Speed is re-adjusted	No display/messages
Significant drop in pump speed	Torque of electric drive motor reduced. Launch control not available. Additionally, forced shift into 2nd gear with downshifting prohibited and reduced maximum speed.	 Gearbox: fault. Safely stop vehicle
No pump speed signal	See "Significant drop in pump speed"	 Gearbox: fault. Safely stop vehicle

Oil cooler

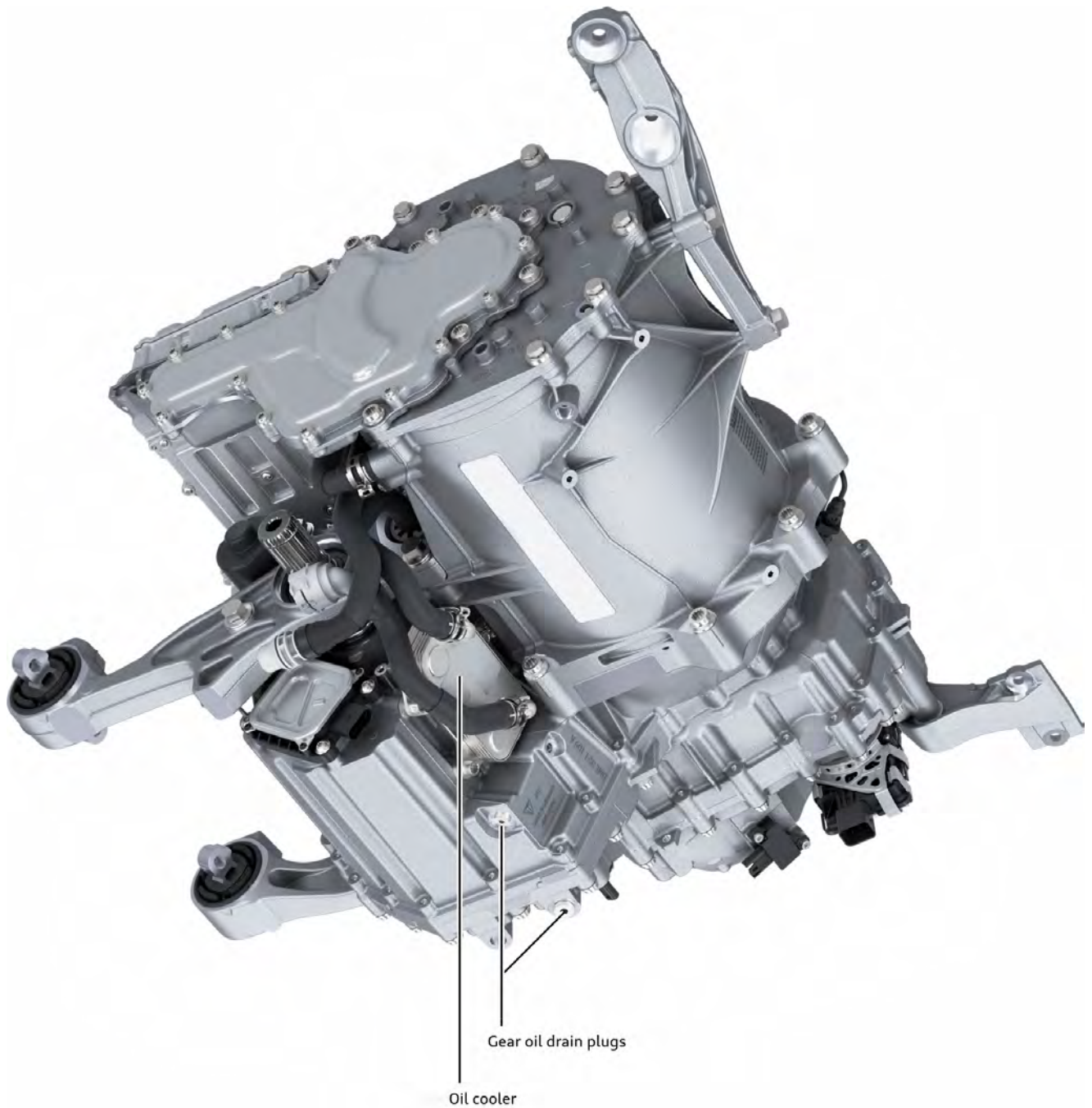

684_355

The gear oil cooler is an oil/coolant heat exchanger. It is integrated in the coolant circuit for the electric powertrain. There is no separate switching valve to decouple the oil cooler from the coolant circuit for the electric powertrain. If the electric drive motor and the power electronics for the rear axle are being cooled, the gear oil for the two-speed rear transmission unit is cooled automatically.

Oil filler and inspection plug and oil drain plugs

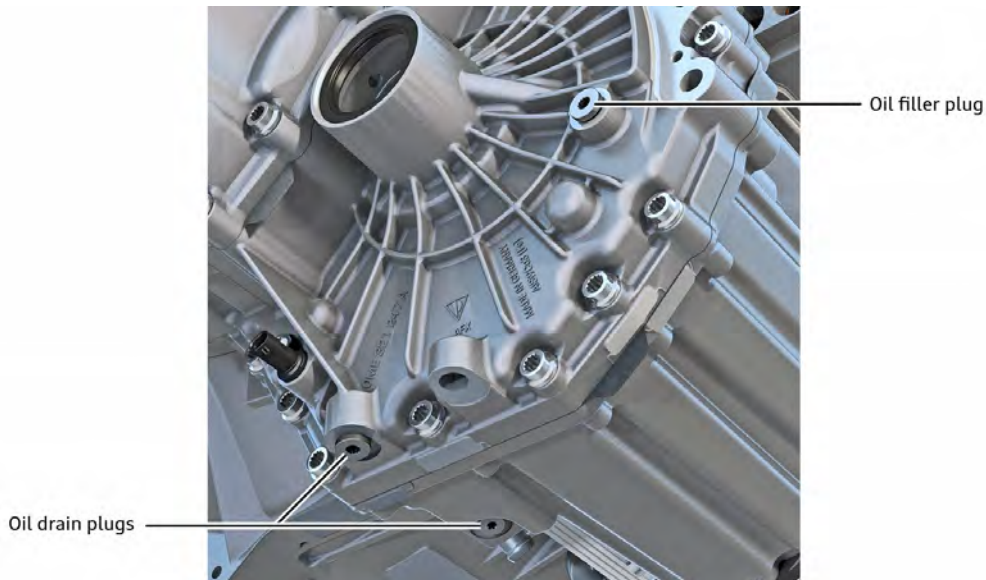

684_356

Two-speed transmission unit OME has two oil drain plugs to allow the oil to be drained completely. The hole for the oil filler plug is used to top up the oil and check the oil level. Please refer to the current workshop information for specifications on the oil capacity and oil type.

Active rear axle differential lock

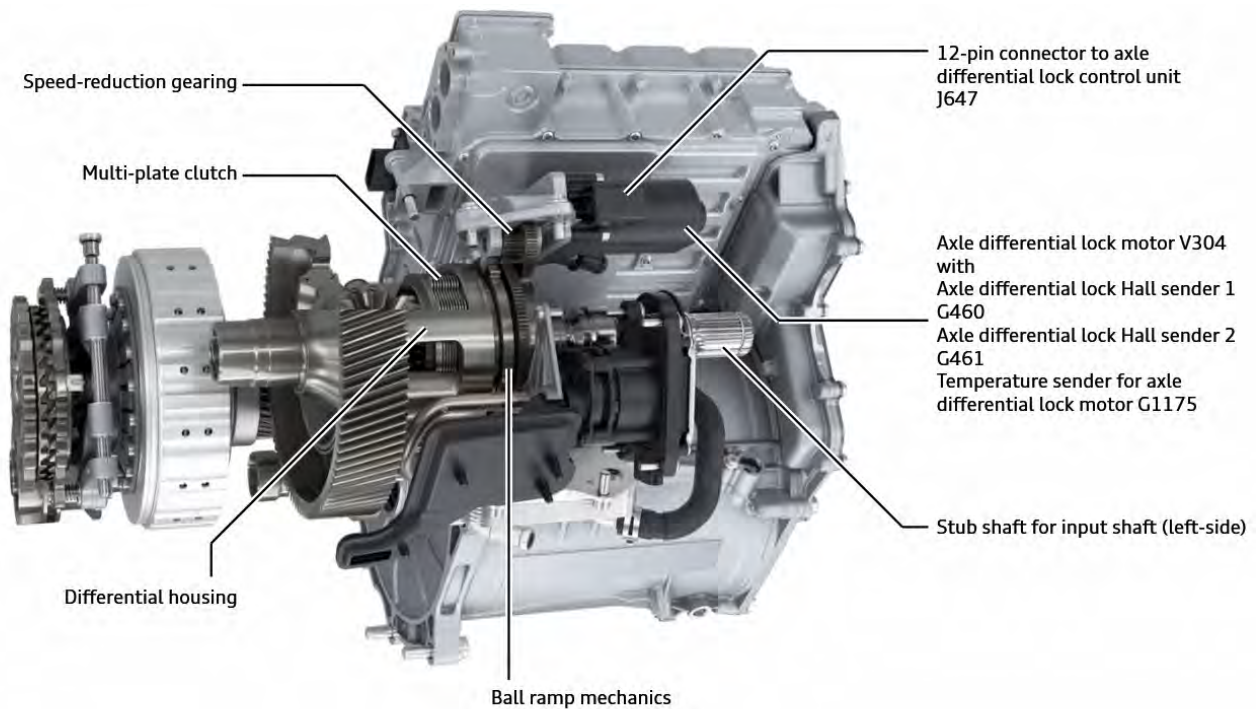

684_357

The Audi e-tron GT is available with an active rear axle differential lock as optional equipment. This differential lock is fitted as standard equipment on the Audi RS e-tron GT. The active differential lock can lock the speed equalisation function in the differential as desired using a multi-plate clutch.

Axle differential lock control unit J647 calculates the desired lock value and actuates axle differential lock motor V304 accordingly.

The two axle differential lock Hall senders G460 and G461 and temperature sender G1175 are contained inside axle differential lock motor V304. The Hall senders allow axle differential lock control unit J647 to infer the position of the rotatable ball ramp ring, and the temperature sender provides information on the thermal load of the motor.

Depending on the desired lock value, axle differential lock motor V304 turns the adjusting ring for the clutch engagement mechanism via reduction gearing. The main components of the clutch engagement mechanism are a ball ramp ring, which can move along the shaft and is mounted so that it does not rotate, the ball bearings and a ball ramp ring that does rotate (referred to as the adjuster ring). The rotational movement of the adjusting ring creates axial movement which pushes the clutch plates together.

The active differential lock works together with the selective wheel torque control of ABS control unit J104 to prevent the wheels from spinning.

The two systems therefore improve:

- > The torque distribution
- > The traction
- > The lateral acceleration potential
- > The driving stability during changes in load when cornering
- > The handling when changing lanes
- > The stability in overrun phases

This makes faster cornering speeds possible. The effect of the differential lock and any application of the brakes by the system are particularly noticeable when driving on surfaces that offer little traction, such as wet or snowy roads.

In contrast to a conventional differential lock (see SSP 613 "Audi R8 Power Transmission", page 28), the active differential lock can be opened completely. This means that the rear brakes can be activated without interference if ABS control unit J104 intervenes.



Note

Axle differential lock control unit is fitted at the rear right inside the luggage compartment. If axle differential lock control unit J647 is renewed, the new control unit must be activated using the vehicle diagnostic tester. If axle differential lock motor V304 is renewed, it must be adapted using the vehicle diagnostic tester to account for component tolerances.

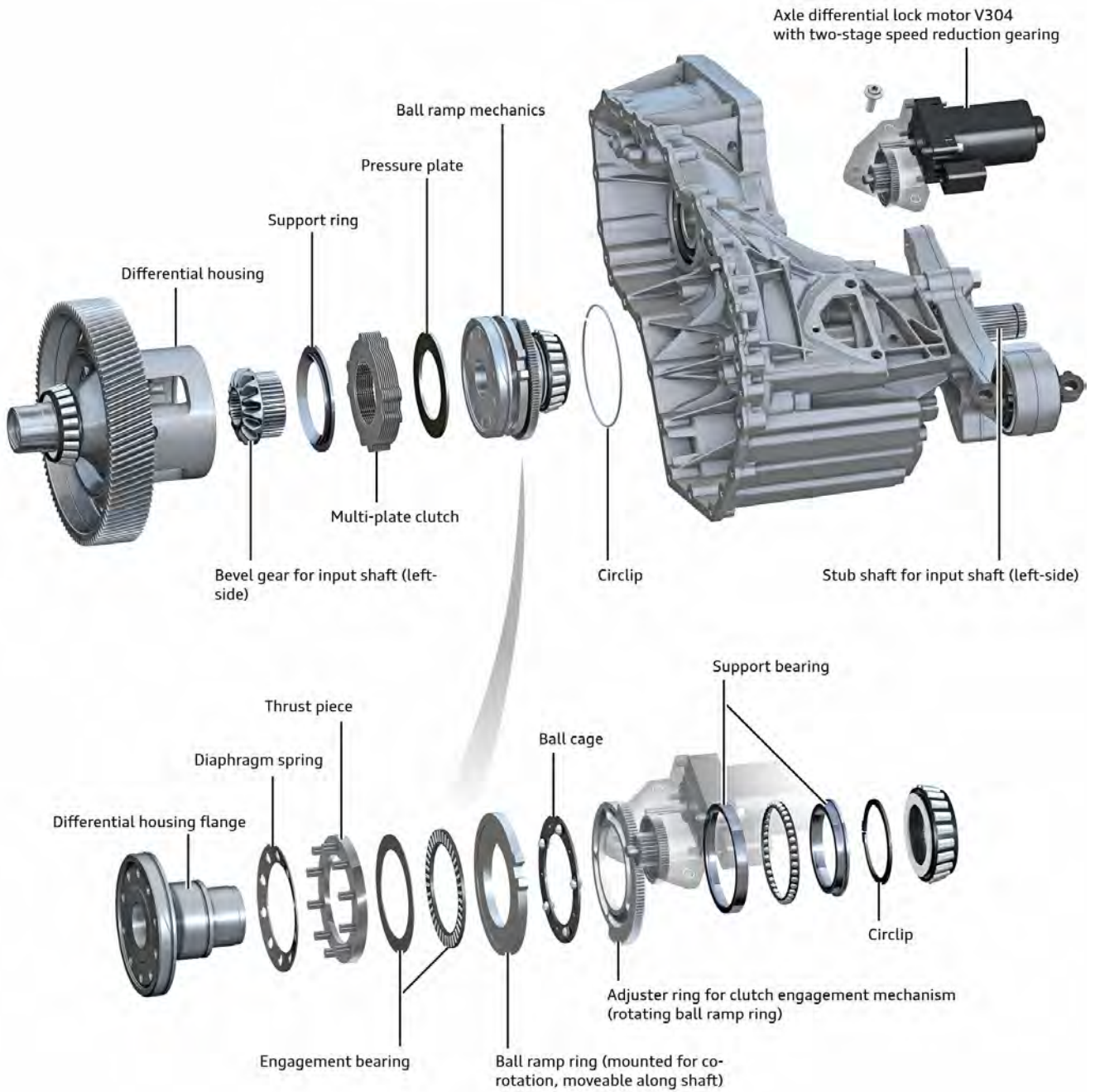

684_350



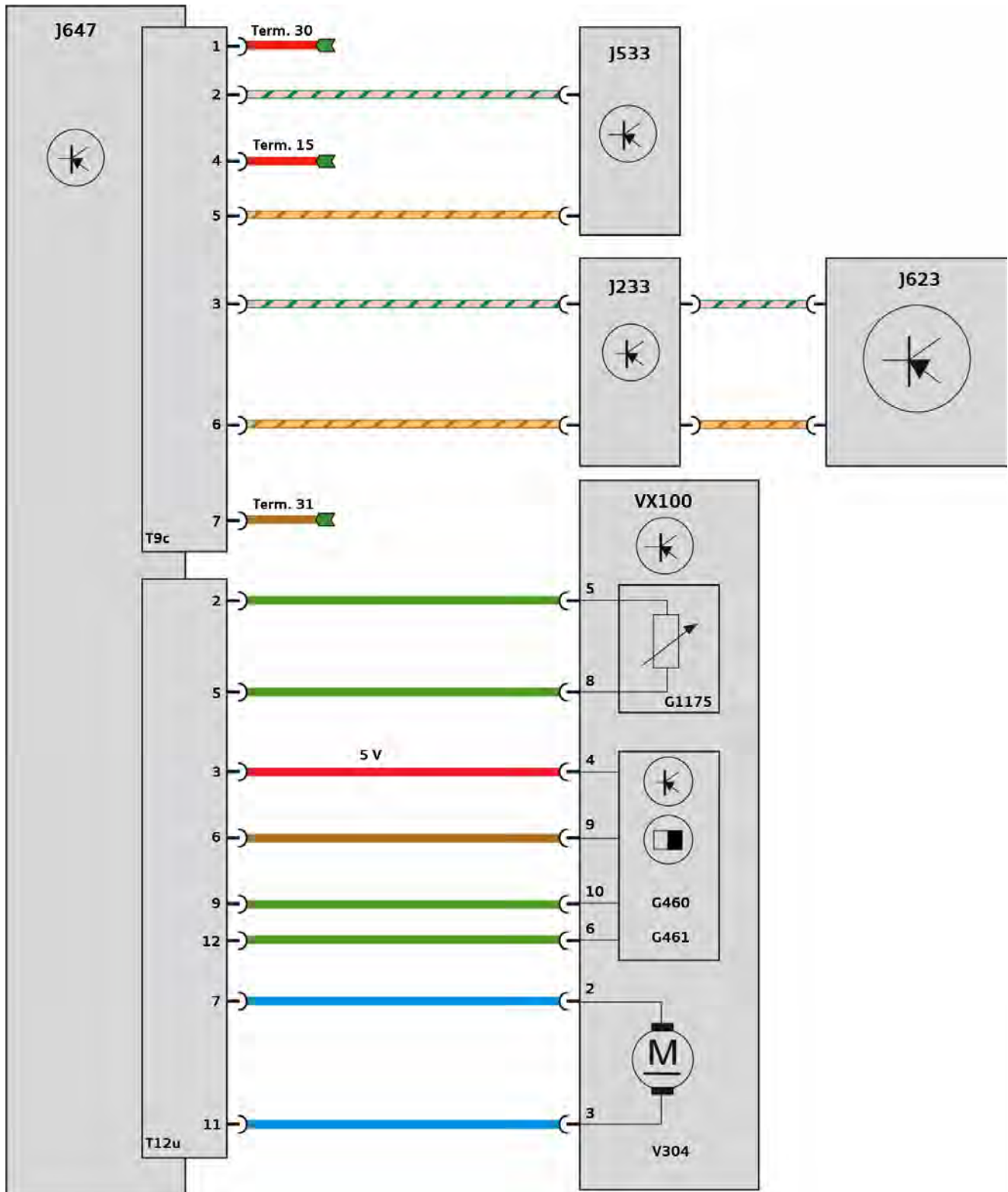



Function diagram - active rear axle differential lock



684_361

Key:

- G460** Axle differential lock Hall sender 1
- G461** Axle differential lock Hall sender 2
- G1175** Temperature sender for axle differential lock motor
- J233** Adjustable rear spoiler control unit
- J533** Data bus diagnostic interface
- J623** Motor control unit

J647	Axle differential lock control unit
V304	Axle differential lock motor
VX100	Axle differential lock
T9c	9-pin connector, grey
T12u	Electrical connector (12-pin); green
	Earth wire
	Positive wire
	Sensor wire
	Actuator wire
	FlexRay High
	FlexRay Low

Service

Towing the vehicle

The vehicle must be transported on a breakdown truck (i.e. with all four wheels on the truck) or a special transporter.

The vehicle must not be towed or push-started.



Note

Note the other descriptions and information on the topic of tow-starting and towing a trailer in the Owner's Manual.

Gearbox warning/indicator lamps



If the red transmission warning lamp appears in the instrument cluster, the driver is instructed not to drive any further.



If the yellow transmission indicator lamp appears in the instrument cluster, it is generally possible to continue driving the vehicle. A corresponding driver message informs the driver of what to do.

For detailed and up-to-date information, please refer to the Owner's Manual.

Diagnosis

Diagnosis is available for the electrical/electronic components and the control operations of two-speed transmission unit OME.

The vehicle diagnostic tester can be used to access diagnostic results and carry out Guided Functions via address words "0001 Engine electronics J623" and "0032 Lock electronics J647".

Some of the available functions are:

0001 – Engine electronics J623

- 0001 Electrical components
- 0001 Engine electronics functions
 - 0001 Renew control unit
 - 0001 VX65 gear actuator
 - Replace VX65 gear actuator
 - 0001 G467 clutch position sender
 - Replace G467 clutch position sender
 - Adapt G467 clutch position sender

0001 – Engine electronics J623

- 0001 G1016 Clutch jaw position sensor
 - Replace G1016 clutch jaw position sensor
 - Adapt G1016 clutch jaw position sensor
- 0001 Replace V552 gearbox auxiliary hydraulic pump
- 0001 Work steps after exchanging components
 - (Collection of various functions within address word 0001 that apply to exchanging components)
- 0001 Gearbox functions
 - Delete gearbox adaptations
 - Adapt gearbox
 - Replace gearbox
- 0001 Read measured values
- 0001 Activation - release of parking lock
- 0001 Check control unit configuration
- 0001 Query used vehicle info
- 0001 Subsystems - boundary conditions

0032 – Lock electronics J647

- 0032 Electrical components
- 0032 Lock electronics, functions
 - 0032 SVM control unit configuration
 - 0032 Read/erase event memory
 - 0032 Renew control unit
 - 0032 Identification
 - 0032 Read measured values
 - 0032 Basic setting
 - (If replacing axle differential lock control unit J647 or the axle differential lock motor)
- 0032 Subsystems - boundary conditions

Running gear

Overview

The main system components of the running gear on the Audi e-tron GT and the Audi RS e-tron GT are largely identical. Any differences will be mentioned specifically in the following chapters. If information about the Audi e-tron GT is given and no differences are mentioned, the information also applies to the Audi RS e-tron GT.

In the standard version, the Audi e-tron GT is equipped with a steel spring running gear with electronic damping control. Air suspension is available as an option in conjunction with electronic damping control (adaptive air suspension). The Audi RS e-tron GT is equipped with adaptive air suspension as standard. Both of the running gears are new developments or evolutions of those in current Audi models.

The four-wheel steering system is available as optional equipment for the Audi e-tron GT. One of the highest priority development goals was to achieve a low vehicle weight. The main axle components are therefore made of aluminum. Running gear control unit J775 is also the coordination platform for the running gear systems in the Audi e-tron GT.

If the required conditions have been met, recuperation takes place via the generator mode of the electric motor(s). The total braking power is then obtained from the hydraulic braking power and the braking power provided by the electric motor(s). The complex regulation of these processes is performed by an electromechanical brake servo in conjunction with a 9th generation ESC system. As on the Audi e-tron, the driver can set the level of recuperation by pulling the paddle levers on the steering wheel.

The standard version of the Audi e-tron GT is equipped with a generously proportioned steel brake system. Carbide-coated brake discs or a ceramic brake system are available as optional equipment. The RS model has the carbide-coated brake discs as standard equipment and can be equipped with the ceramic brake system as an option.

The range of available wheels spans from 19" (for the e-tron GT) and 20" (for the RS e-tron GT) in the standard equipment version, to optional 21" wheels. Specially developed optimised rolling resistance tires reduce rolling resistance and help to increase the range.

The third-generation Tire Pressure Monitoring System with direct measurement completes the comprehensive standard equipment.



684_392

Axles

Overview

The axles of the Audi e-tron GT are evolutions on the basis of the axle technology of the Porsche Panamera and Porsche Taycan. Double wishbone axles are used at the front and the rear. The rear axle is a double wishbone axle with separate upper wishbones. This means that one wishbone is used for the lower section while the upper section is "split" into two individual wishbones.

This type of axle construction mainly provides packaging benefits. In the development of this vehicle, a particular emphasis was placed on lightweight construction. The subframe, wheel bearing housings and wishbones on the front axle are made of aluminum. On the rear axle, this applies to the subframe, hub carriers, wishbones and track rods.

Front axle

System components

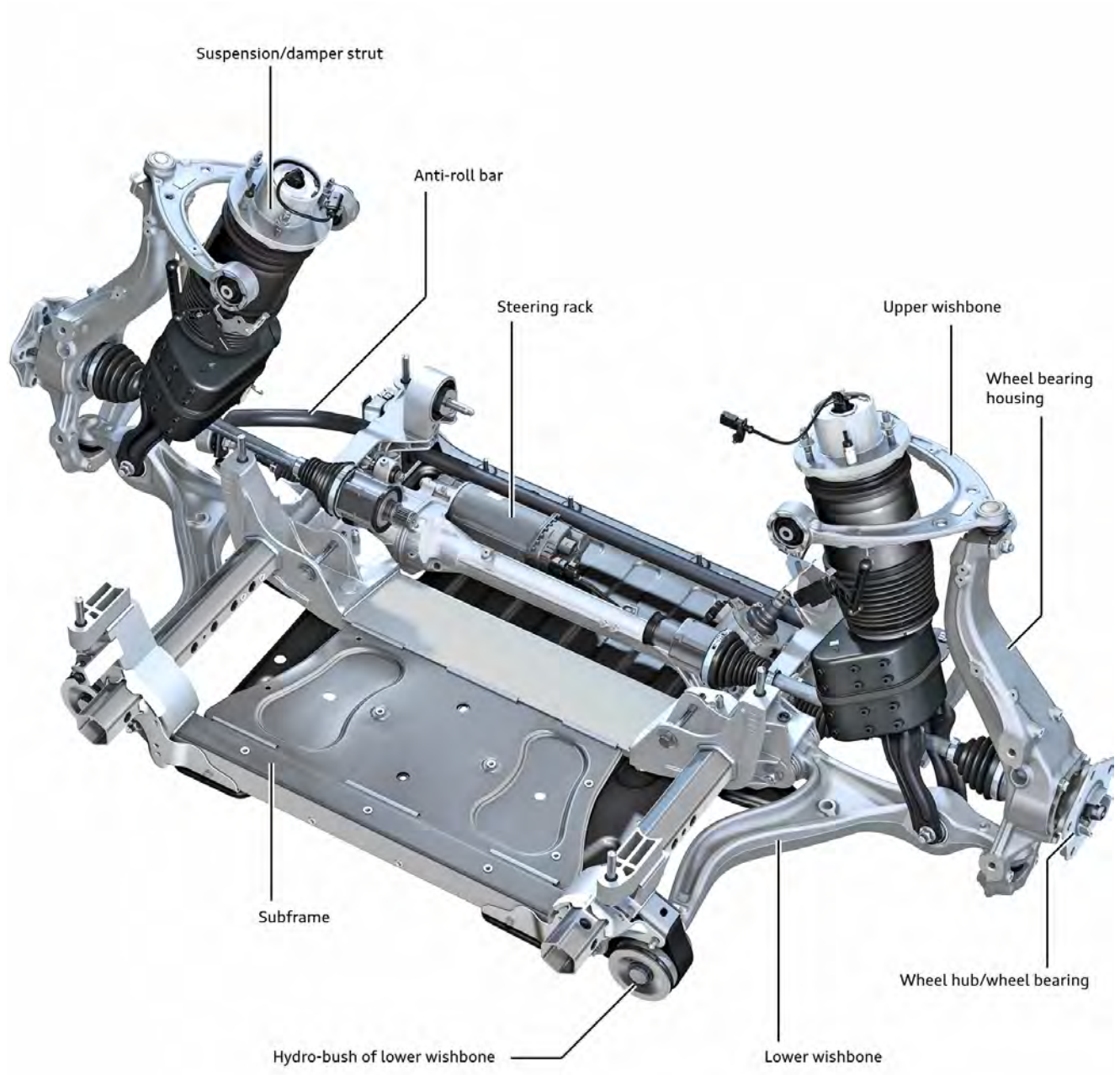

684_091

Subframe

The subframe is a welded construction made of four aluminum node castings connected by aluminum extrusions. This type of construction allows for high rigidity and low weight. The lower wishbones, the steering rack, the anti-roll bar and the assembly mountings are fitted on the subframe. Two reinforcement panels which are bolted to the subframe from below are used in addition to increase rigidity.

The subframe is fixed in place on the vehicle body with bolts at six mounting points.

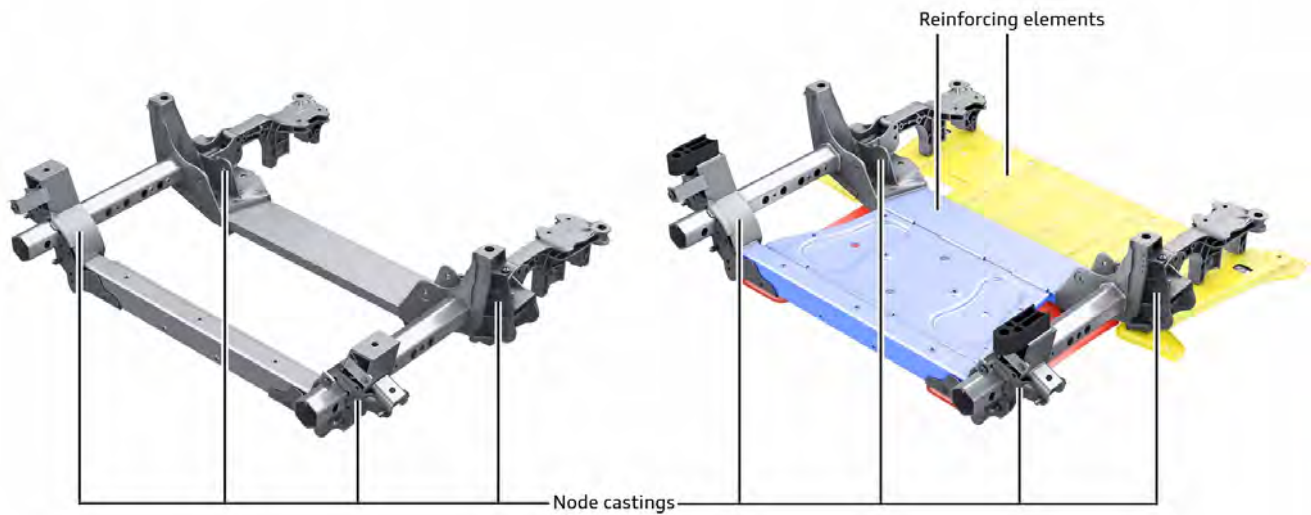

684_426

Wheel bearing housings

The wheel bearing housings are hollow aluminum castings. The upper and lower wishbones and the steering rack's track rods are connected to them by ball joints. The brake calipers and wheel hubs/wheel bearings are bolted directly onto them. In the upper section, they also provide the connections for the anti-roll bar coupling rods.



684_382

Wishbones

The upper and lower wishbones are forged aluminum components. This manufacturing technology provides high mechanical rigidity under compression, tensile and bending loads while keeping the mass of the components low. The upper wishbones are connected to the vehicle body with large bonded rubber bushes. The lower wishbones are fitted in the subframe on the vehicle body side. A bonded rubber bush is also used for the front mounting position; the mounting at the rear has a hydraulically damped bush. The suspension struts are also connected to the lower wishbones.

Hydro-bush of lower wishbone



684_383

Lower wishbone



684_384

Upper wishbone



684_385

Anti-roll bar

Tubular anti-roll bars with coupling rods are used. These are coupled at the wheel bearing housings. The anti-roll bars are mounted on the subframe in bonded rubber bushes.



684_405

Wheel hub/wheel bearing

The wheel hub and wheel bearing are flanged to the wheel bearing housings as one unit. The wheel hub can be pressed out of the wheel bearing in service. A magnetised impulse ring, which works as an impulse sender for the wheel speed sensor, is integrated in the wheel bearing seal.



684_406

Suspension/damper strut

Single-tube dampers (gas struts) are standard equipment and can be regulated in non-compression and compression stages. The regulating valve inside (which has continuous adjustment) is activated by running gear control unit J775 via a wire going through the piston rod. In the neutral condition (not electrically activated), the damping force is low ("soft" characteristic).

Steel springs are used in the standard equipment version.



684_428

Service operations - new special tools

Several tools which were previously only used for assembly work on Porsche vehicles are used to remove/install axle components. One example is the spring compressor VAS 6908, which is used to remove/install the suspension strut on the front axle (refer to Workshop Manual).

Rear axle

System components

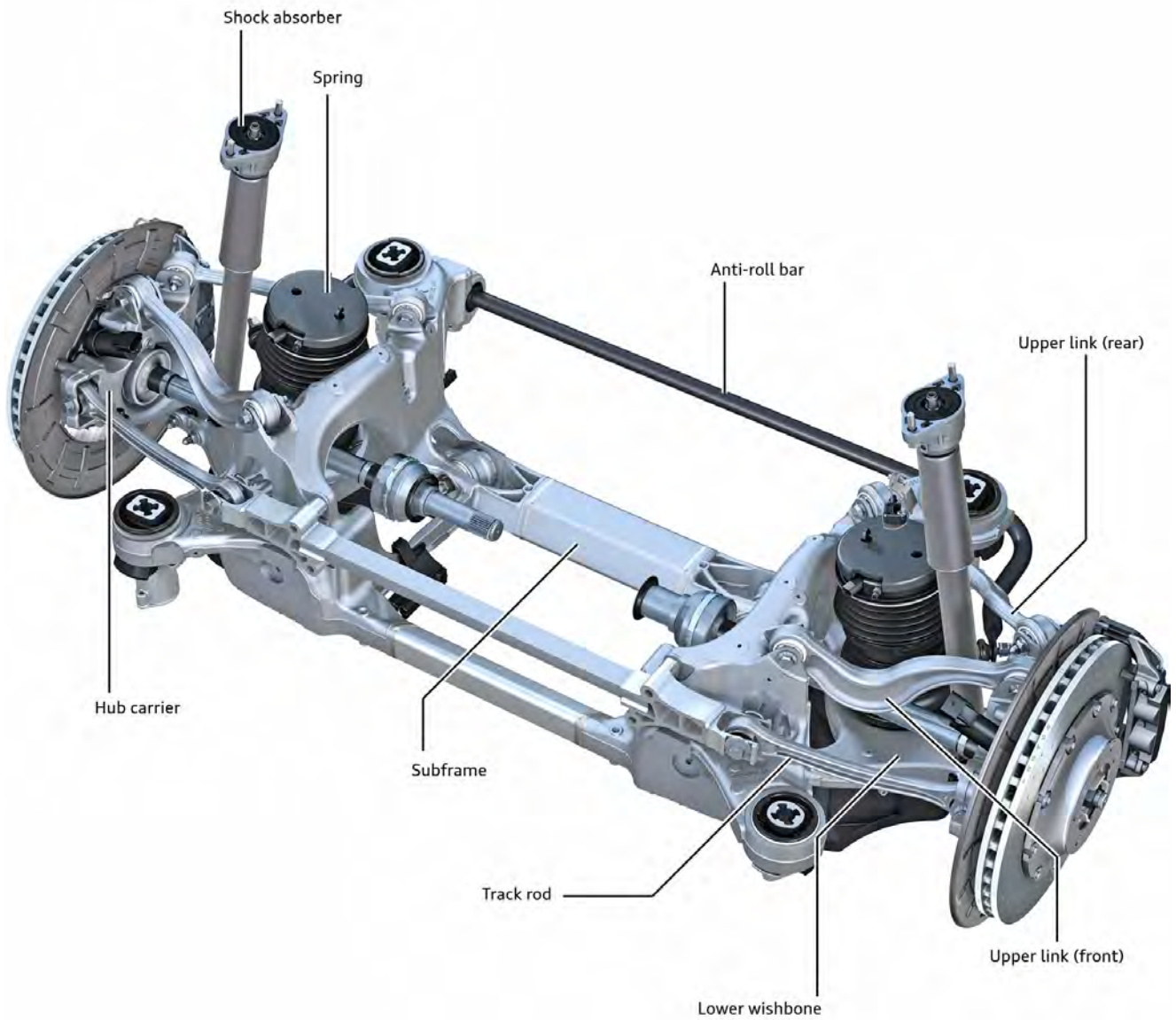

684_092

Subframe

The subframe serves as the mounting for the wishbones, the anti-roll bar and the steering rack for the rear wheel steering (optional). It is decoupled from the vehicle body by four hydraulically damped bushes and made of aluminum gravity die casting.

If the vehicle is equipped with four-wheel steering, the rear wheel steering module is fitted instead of the cross member.

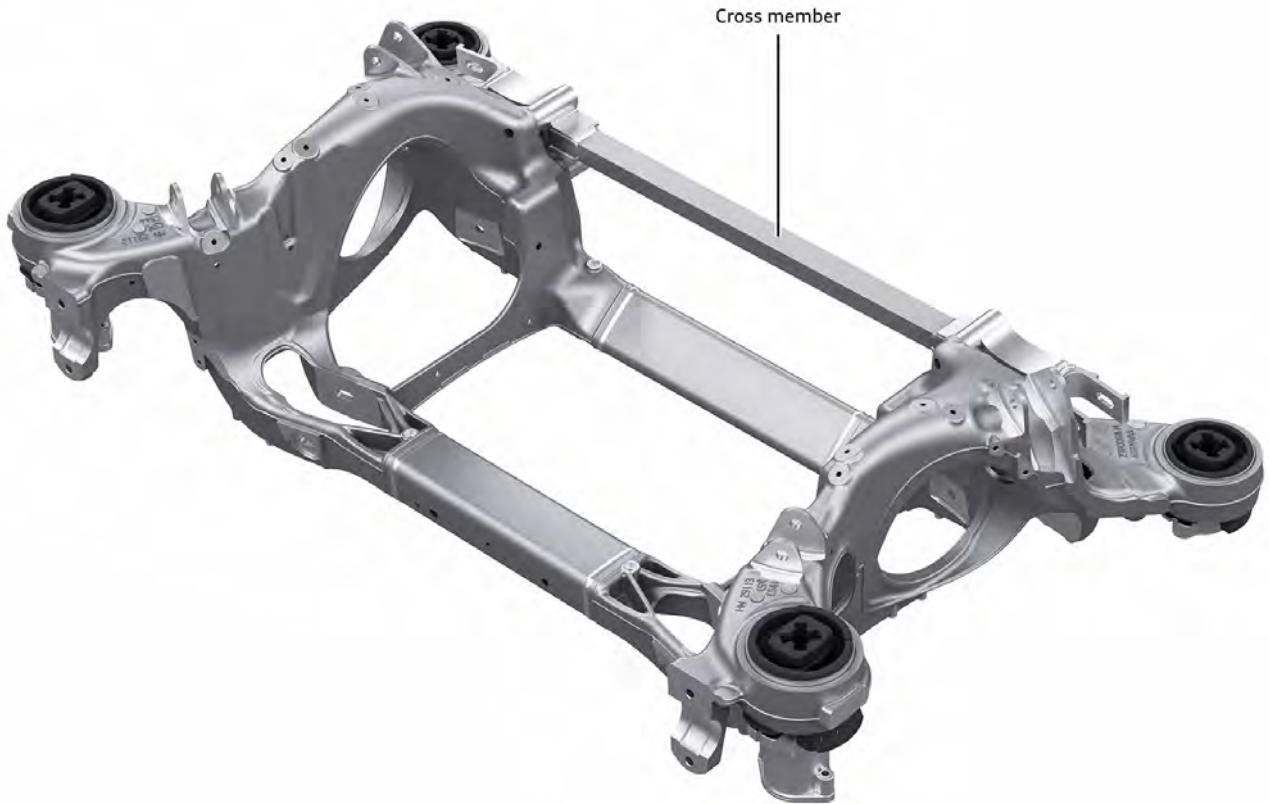

684_387

Hub carriers

The hub carriers are aluminum castings. The wishbones and track rods are connected with bonded rubber bushes. The wheel hubs/wheel bearings are secured with flange connections. The brake calipers and the actuators of the electromechanical parking brake are also connected to the hub carrier.



684_386

Upper wishbones

The two upper wishbones are forged aluminum components. They are connected to the subframe and hub carrier with bonded rubber bushes.



684_388



684_389

Lower wishbones

The lower wishbones are made of aluminum and manufactured using the gravity die casting process. They are also connected to the subframe and hub carrier with bonded rubber bushes. Cup-shaped indentations serve as mountings and supports for the springs. The dampers are fitted in the outer section between the spring mountings and the connections for the hub carriers. The coupling rods for the anti-roll bars are fitted in bonded rubber bushes at the side.

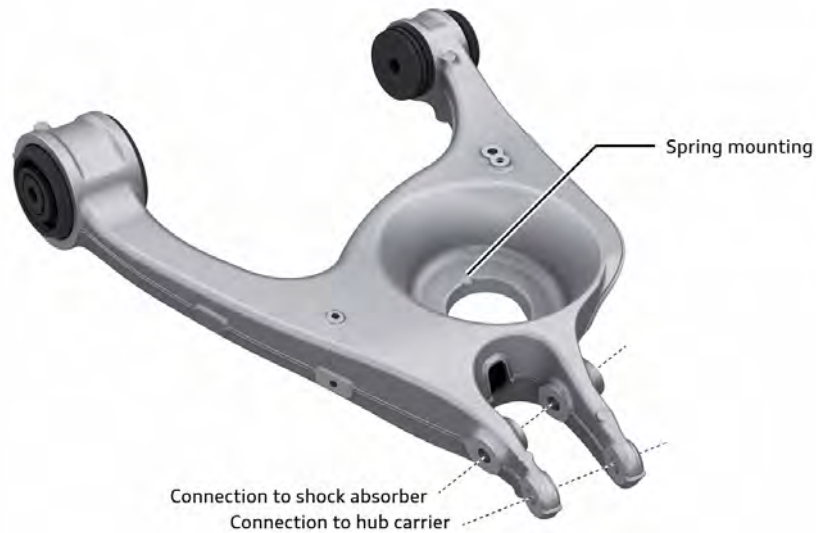

684_393

Track rod

The track rods are forged aluminum components. They are connected to the subframe and the hub carrier via bonded rubber bushes. If the vehicle is equipped with four-wheel steering, the connection on the axle side is made in the forks of the rear axle steering rack's spindles.



684_394

Wheel hub/wheel bearing

A third-generation wheel bearing unit is used. The wheel hub and the wheel bearing form one unit which is flanged to the hub carrier. The wheel hub can be pressed out of the wheel bearing if necessary. A magnetised impulse ring, which works as an impulse sender for the wheel speed sensor, is integrated in the wheel bearing seal.

Anti-roll bar

Tubular anti-roll bars with coupling rods are used. These are coupled at the lower wishbones. The anti-roll bars are mounted on the subframe in bonded rubber bushes.



684_404

Shock absorber

Single-tube dampers (gas struts) are fitted and can be regulated in non-compression and compression stages. The regulating valve inside (which has continuous adjustment) is activated by running gear control unit via a wire going through the piston rod. In the neutral condition (not electrically activated), the damping force is low ("soft" characteristic).



684_395

Wheel alignment

The wheel alignment procedure corresponds to that of other Audi models. There are some differences when preparing the vehicle for wheel alignment. The process is specified in the new Guided Function of the running gear control unit J775: "0074- Establish / reset preconditions for vehicle alignment".

After successful changes to the wheel position values, sensors/systems affected must be re-adapted/calibrated. Please follow the instructions in the Workshop Manual and the wheel alignment computer.

Special preparations must be made before starting wheel alignment on vehicles with adaptive air suspension and/or four-wheel steering. The precise vehicle level required for wheel alignment must be set and height regulation must be deactivated at this level. The wheels on the rear axle must also be tightly locked in zero position. On the Audi e-tron GT, these functions no longer need to be activated separately via the corresponding control units. This task is undertaken by the previously mentioned function "0074- Establish / reset preconditions for vehicle alignment". The specified function is also used for vehicles with electronic damping control, although in this case without the functions specific to air suspension.

Front axle

On the front axle, the toe settings for each wheel can be adjusted at the track rods.

The camber values can be aligned by moving the subframe to the side.

Rear axle

The toe setting at each wheel can be adjusted at the bolted connections for the track rods with the subframe or with the spindle of the rear axle steering rack.

The camber values on the left and right sides can be set independently of each other. The eccentric bolts used to connect the front lower wishbones to the subframe can be used to do this.

A new special tool (T90009) is used to set the toe.

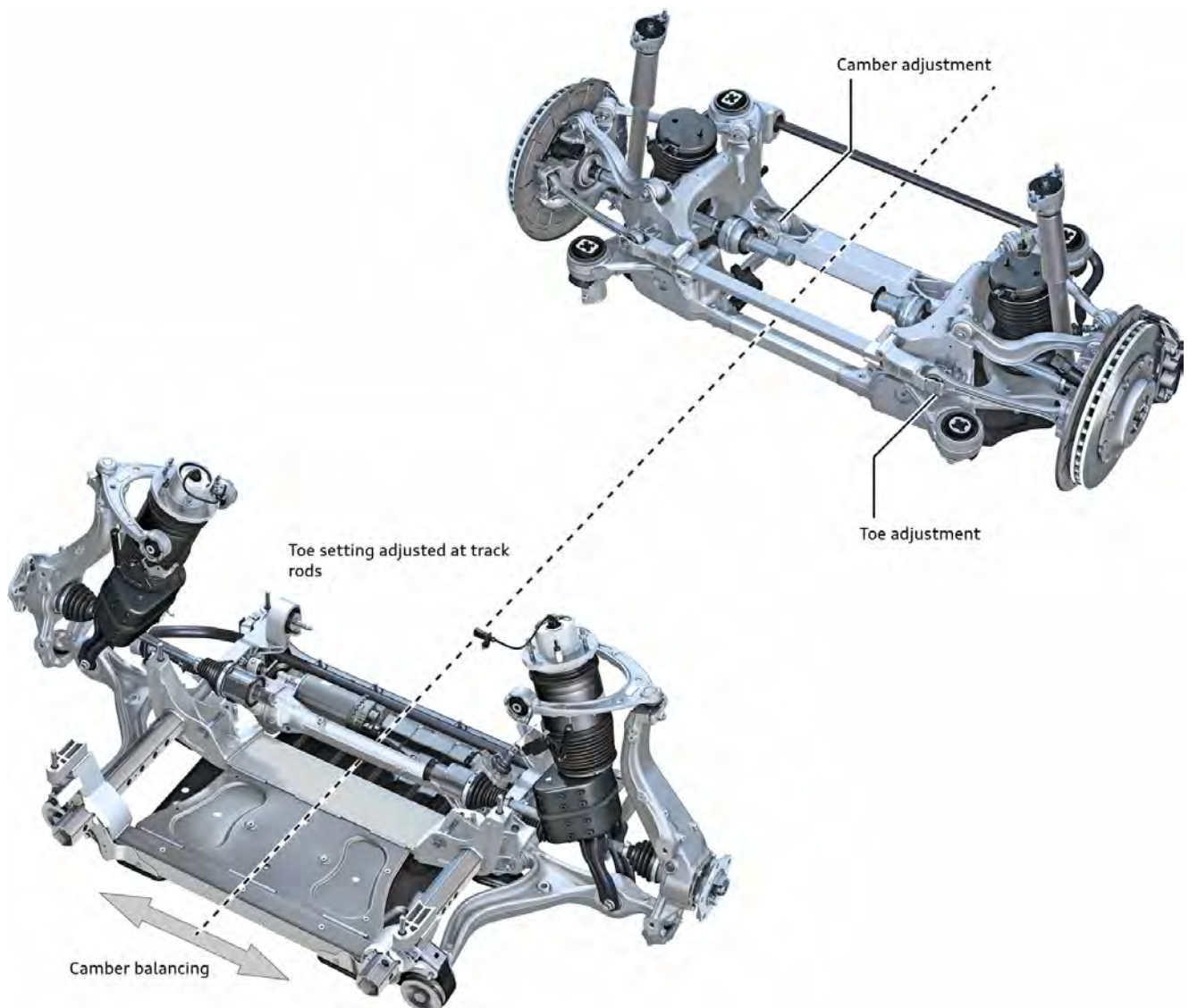

Adaptive air suspension

Overview

Adaptive air suspension with electronic damping control is standard equipment on the Audi RS e-tron GT and optional equipment on the Audi e-tron GT. The system's construction fundamentally corresponds to the adaptive air suspension systems used on other Audi models, in particular the Audi Q7 (type 4M). However, the system components partially vary and are presented in detail below. Air springs with three separate air chambers are being used in an Audi model for the first time.

This allows different air spring volumes to be achieved using integrated electrically switchable valves. Another new feature is that the acceleration of unsprung masses can be detected by four separate sensors. The running gear control unit J775 remains the control centre for the air suspension and damping on the Audi e-tron GT.

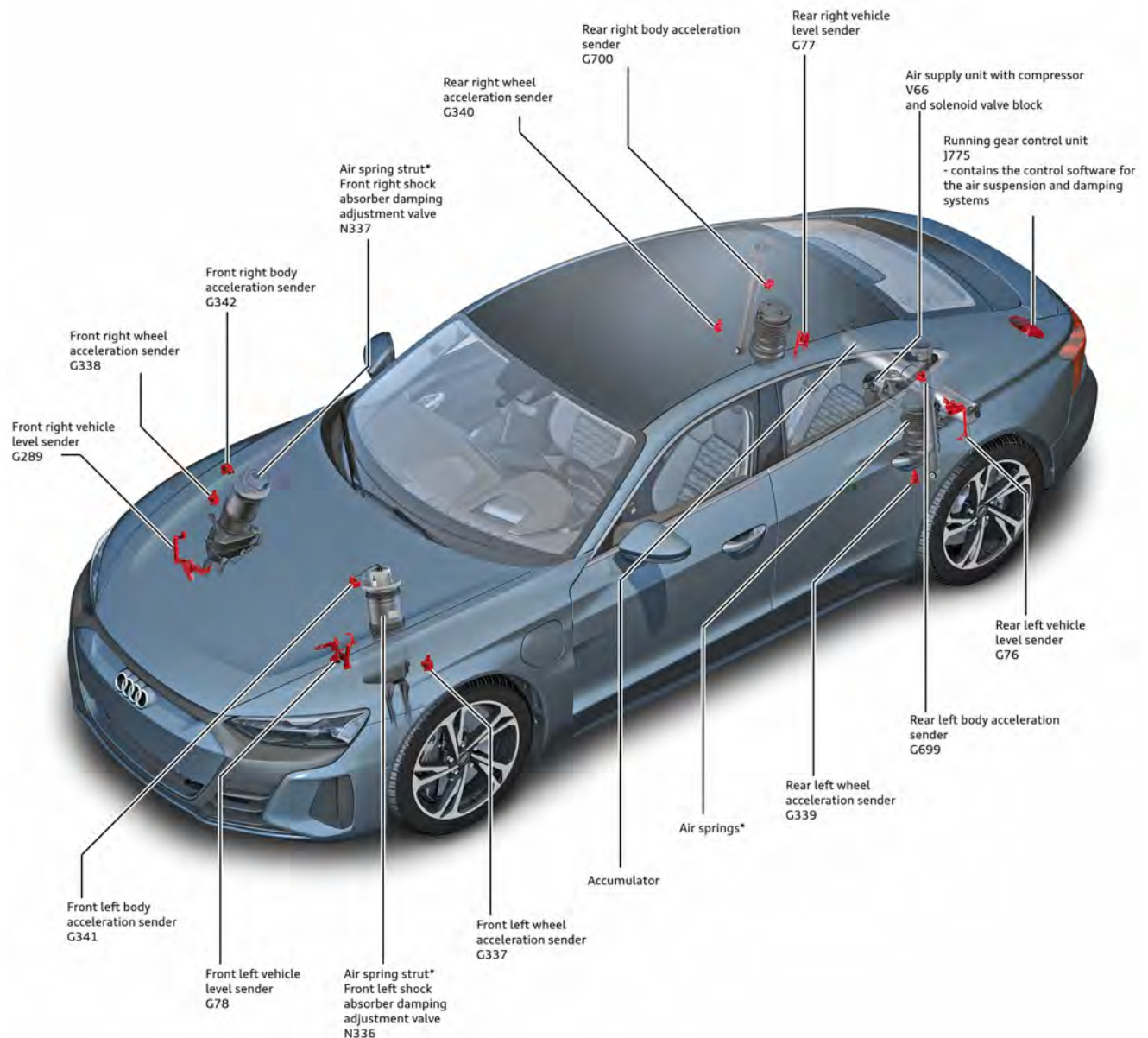

* Contain the following additional air spring volume valves:
 Valve 1/2, front left N670/N671
 Valve 1/2, front right N672/N673
 Valve 1/2, rear left N674/N675
 Valve 1/2, rear right N676/N677

684_243

System components

Running gear control unit J775

Overview

As with other Audi models on the MLB platform, the running gear control unit is also the central regulating unit for various running gear systems on the Audi e-tron GT. The tasks of the control unit include damping control and regulation of the vehicle level (adaptive air suspension). The basis of this is an analysis of the current dynamic driving state (evaluation of longitudinal, lateral and vertical acceleration along with the yaw, roll and pitch rate) in real time. These data (from external sensors (refer to image “684_342”)) are the basis for determining the driving state. The control unit communicates via FlexRay channel A, which is fitted in the luggage compartment (left-side).

Data transfer

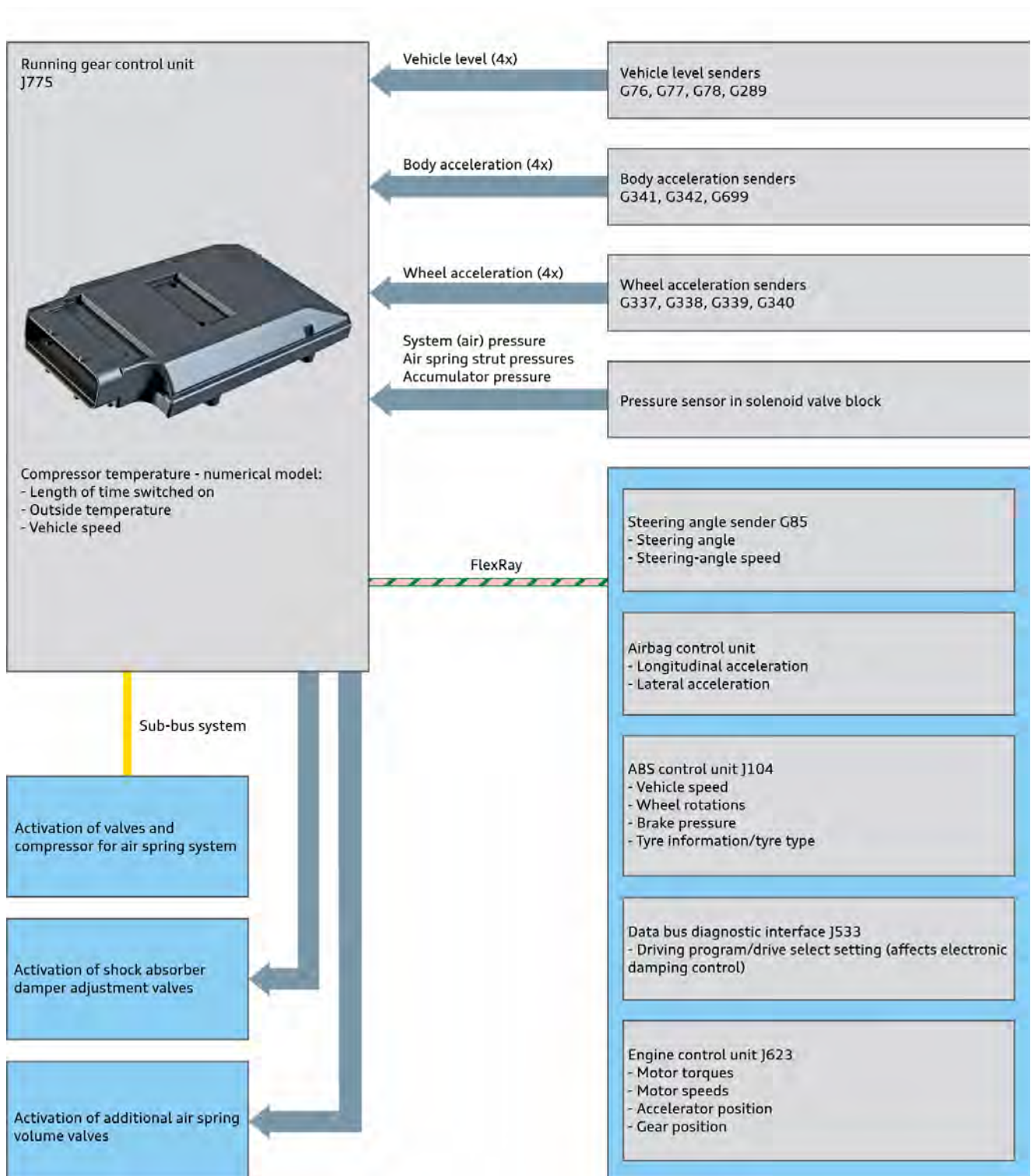

684_342

Service operations

The following new features regarding the air suspension are present in the service functions of control unit J775 in the Audi e-tron GT:

A new function “0074 - Replacement work on air suspension system” has been introduced to replace air springs. In the sub-menu, the user can select whether just one air spring is to be replaced or whether the entire system is to be bled/filled up. As previously, the vehicle must be on a lifting platform with its wheels off the ground before work is started. This prevents damage to the air springs which are bled. Regulation by the program is deactivated at the beginning of the bleeding process. The system is bled on the basis of an accompanying pressure measurement up to a maximum remaining air spring pressure of approx. 4 bar. Only then can the air system be opened safely to remove the air spring affected.

The system is filled using the accumulator. A minimum air pressure of 12 bar is required to do this. If the measured accumulator pressure is lower, the accumulator is initially filled to a pressure of >12 bar. The system is then filled a maximum of 10 times. If the minimum pressure cannot be reached, the mechanic is informed that there is a system fault (e.g. a leak). The air spring(s) are also filled on the basis of an accompanying pressure measurement. An air pressure of between approx. 4 bar and a maximum of 7.2 bar will be set. The height regulation will be reactivated after the system has been filled successfully.



Note

It is very important that you observe the information in the Workshop Manual related to handling the air springs. Incorrect handling may cause damage or premature failure.

If the “Venting / filling entire suspension system” function is performed, the air dryer is regenerated after the system has been filled. This involves fully bleeding the accumulator and then filling it back up to a pressure of approx. 18.5 bar. In the bleeding process, dry air flows through the dryer and transports the moisture bound in the drying granulate out of the system into the atmosphere.

Additional diagnosis functions correspond to those in other Audi models. After removal/installation of certain components (e.g. control unit J775, vehicle level senders), the vehicle height level must be re-adapted on vehicles with adaptive air suspension or electronic damping control.

System faults are indicated to the driver via the activation of the familiar air spring symbol in conjunction with an explanatory text. The relevant messages are described in the Owner's Manual. Depending on the fault category, the symbol is either red or yellow, as on previous vehicles.



Air spring strut, front axle

The air springs on the front axle consist of three differently-sized chambers which are connected together. Two electrically switchable valves can be used to separate chambers. One valve separates volume 1 from volume 2, the other separates volume 1 from volume 3. There is no direct link between volume 2 and volume 3. As a result, it is possible to achieve three different air volumes. The larger the air volume achieved is, the smaller the spring rate will be. This makes spring extensions and compressions correspondingly more comfortable. Smaller air volumes with larger spring rates are more suitable at high speeds or for dynamic driving. Because the air volume can be changed quickly depending on the situation, it is particularly easy to regulate the suspension to react to different driving conditions.

Air spring volumes:

Volume	Feature
Volume 1 + volume 2 + volume 3	Highest volume, lowest spring rate, most comfortable setting
Volume 1 + volume 2	Medium volume
Volume 1 + volume 3	Small volume, high spring rate, dynamic setting
Volume 1	Smallest volume, highest spring rate, most dynamic setting

At vehicle speeds of < approx. 220 km/h and little or no longitudinal or lateral influences, all three air volumes are usually activated. At high speeds or in the event of increasing dynamic influences (lots of corners, braking and acceleration), volumes 2 or 3 may be switched off as necessary.

The switching valves are directly activated by running gear control unit J775 via two discrete wires. In their neutral, non-activated status, both valves are open (low spring rate - “soft” suspension). This status is present after the vehicle has been parked and as part of certain faults which lead to regulation being deactivated.

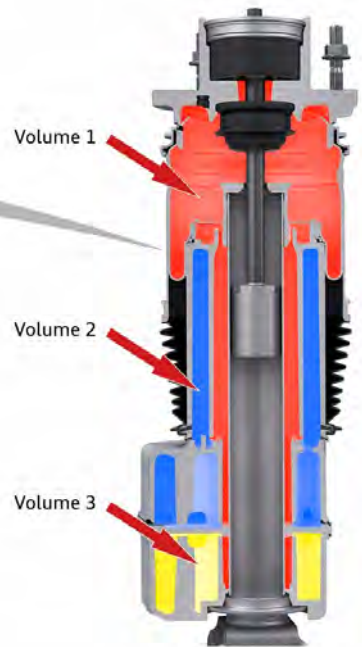
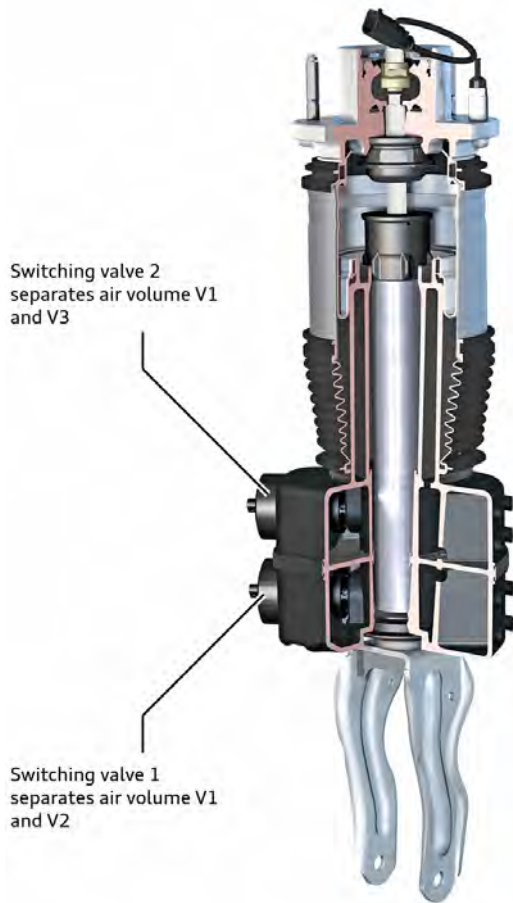

684_436



The plastic housing has small rounded bumps that create predetermined breaking points in the event of a crash. This prevents the high-voltage components from being damaged by shards or broken pieces.

684_397

Air spring on rear axle

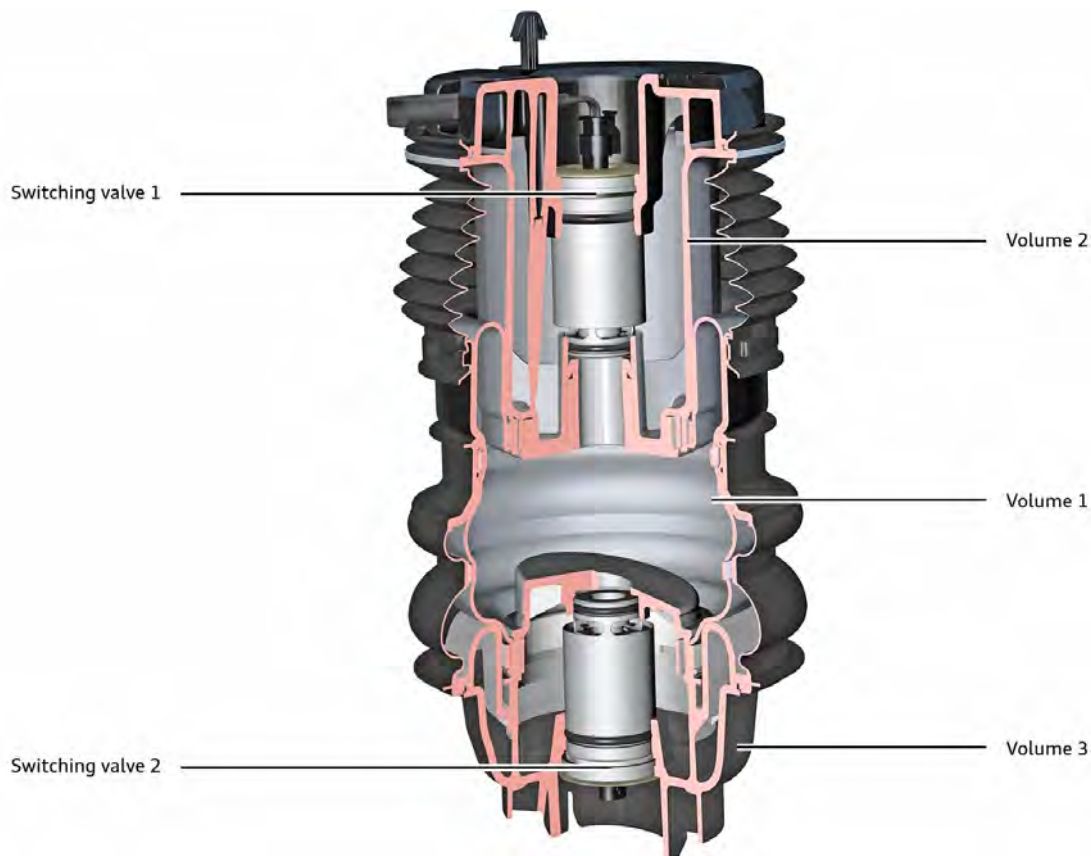

684_255

Springs and dampers are fitted in a separate layout on the rear axle as individual components. The air springs on the rear axle also consist of three chambers which are connected together. Two electrically operated valves can be used to separate chambers. The system works in the same way as the air spring system on the front axle.

Air supply unit

The compressor generates the relative system pressure of approx. 18 bar (maximum pressure approx. 25 bar). It compresses the air drawn in via the intake silencer and the filter in a two-stage compression process. The electric compressor works with two pistons. Its design and functions correspond to the component in the Audi Q7 (type 4M).



Reference

For further information, please refer to (refer to chapter "Chassis with air suspension and electronic damper control (adaptive air suspension)") in SSP 633 "Audi Q7 (type 4M) Chassis."

The air supply unit is also fitted at the rear of the vehicle in the Audi e-tron GT. Rubber bushes ensure effective acoustic decoupling and reduce the amount of structure-borne sound in in the body structure. Additional components of the air supply unit are the air dryer and a solenoid valve for the boost function. The module also includes a pneumatically operated exhaust valve and a solenoid valve to actuate it. The design and construction again correspond to that of the of the compressor module in the Audi Q7 (type 4M) and the description in SSP 633.

A pressure relief valve is fitted in the compressor module of the Audi e-tron GT. When air is released or pressure is dissipated in the system, this ensures that the system pressure does not drop below 2 bar. The residual pressure valves fitted directly on the air connections of the air spring struts on some other Audi models are also fitted on the Audi e-tron GT. This ensures that a small air pressure of approx. 1.5 bar remains in the air springs even in the event of a loss of pressure due to leakages in the lines.

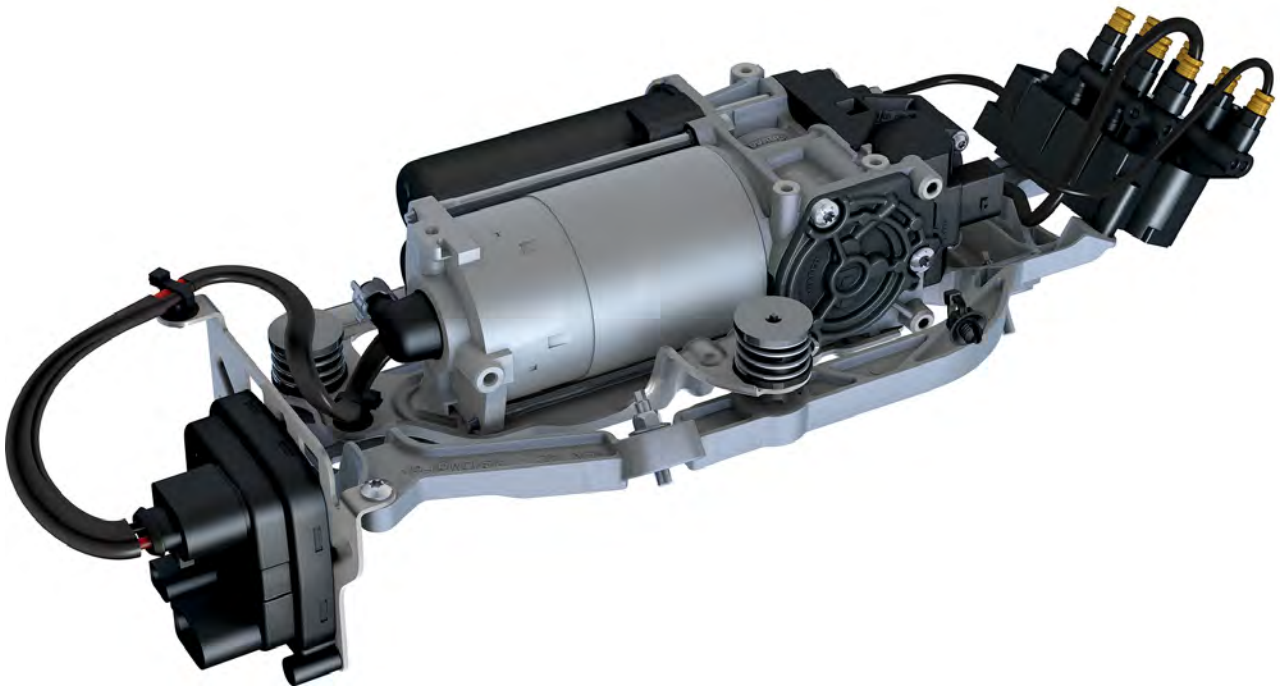

684_093

The electric motor is activated by a separate control unit which is fitted on the same bracket. As on the Audi Q7 (type 4M), activation is via a PWM signal. This makes it possible to start the motor “gently” without significant current peaks. A compressor-temperature model has also been implemented on this control unit. It monitors the compressor temperature on the basis of the outside temperature, vehicle speed and compressor running time. If defined temperature values are exceeded as part of this, regulating processes upwards (raising the vehicle by actively running the compressor) are restricted or disabled until the temperature falls accordingly. At this time, no mode changes can be made in Audi drive select which would require the vehicle to be raised.



684_399

Solenoid valve block

The solenoid valve block has the same design and functional principle as in the Audi Q7 (type 4M).



Reference

For further information, please refer to (refer to chapter “Chassis with air suspension and electronic damper control (adaptive air suspension)”) in SSP 633 “Audi Q7 (type 4M) Chassis.”



684_400

Accumulator

The cylinder-shaped accumulator is made of aluminum and has a capacity of 8 litres. It is fitted in the rear of the vehicle. Regulating processes are performed using the pressure in the accumulator as a priority. This is done to limit the running time of the compressor and to improve the interior acoustics. This requires sufficient pressure in the accumulator. The accumulator is filled up while the vehicle is moving. The vehicle can be raised from the low level to the normal level approx. four times with the accumulator filled up (to a system pressure of approx. 18 bar). The control unit determines the pressures in the air springs and the accumulator by activating the correspondingly allocated solenoid valves and taking measurements via the pressure sensor integrated in the solenoid valve block. These measured values form the basis for calculating the pressure differences between the accumulator and the corresponding air spring. There must be a pressure difference of approx. 2 bar between the accumulator pressure and the air spring pressure to increase the air volume in an air spring with the help of the accumulator. The accumulator also “provides” the energy for the boost function, thereby ensuring that pressure can be built up quickly.



Reference

For further information on the pressure measurement and boost function, please refer to SSP 633 "Audi Q7 (type 4M) Chassis".



684_401

Vehicle level senders

The four vehicle level senders are Hall senders and provide the processed measured values to the running gear control unit in the form of PWM signals. The four senders on the front and rear axles are identical. The brackets and linkages have been geometrically adapted to the different connection points on the front and rear axle.

The service operations for removal and installation or replacement correspond to those for the vehicle level senders already in use in other Audi models. Calibration is required after a sender is replaced: 0074 – Basic setting – Calibration of height sensors.

Any sensors/systems affected must subsequently be re-adapted/calibrated.



Note
Please note the instructions in the Workshop Manual.

Vehicle level senders on front axle



684_164

Position of vehicle level sender on front axle – lever/linkage connected to upper wishbone

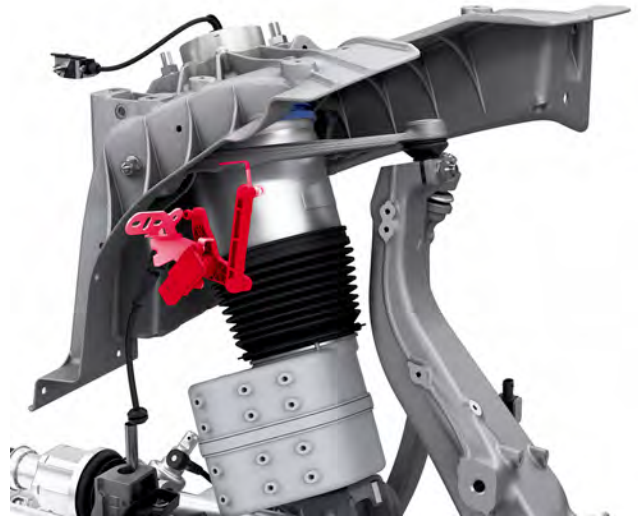

684_402

Vehicle level senders on rear axle



684_217

Position of vehicle level sender on rear axle – lever/linkage connected to lower wishbone

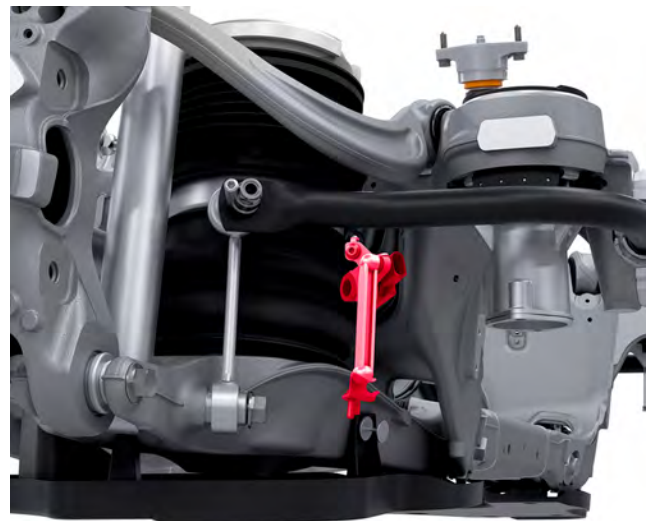

684_403

Wheel acceleration senders

The four wheel acceleration senders are being used on an Audi model for the first time. They detect the accelerations of the wheels/the unsprung masses in the vehicle's vertical (z) and lateral (y) directions. The measurement is made using the seismic mass principle.



684_165



Reference

Further information on how this measurement works can be found in SSP 458 "Audi A8 10 Running gear and suspension" in the section "Control unit for sensor electronics J849".

The senders are fitted on the hub carriers of the front and rear axles.

The technical basis is the PS15 sensor bus system (Peripheral Sensor Interface 5). This standardised system is very effective and has low data transfer rates of <200 kbit/s. The sender is directly connected to the running gear control unit via a two-wire bus. The sensor uses this bus both for data transfer and for its power supply from the running gear control unit. The running gear control unit controls the communication via synchronisation impulses which are answered by the sender with corresponding data packages. The running gear control unit converts the signals received at a frequency of 120 Hz into digital square-wave signals and decodes the data received.

No further activities (calibration etc.) are required after a wheel acceleration sender is replaced in service.

It is possible to check whether the sender is fundamentally working properly by tipping it 180° out of its normal installation position. If the sender is working correctly and the wiring is intact, negative actual values will be displayed as measured values.

Position of wheel acceleration sender on front axle



684_214

Position of wheel acceleration sender on rear axle



684_215

Body acceleration senders

The four senders measure the acceleration of the vehicle body. This means the sprung masses in z direction and the longitudinal accelerations in x direction. In the area of the front axle, the senders are fitted on the suspension turrets and at the rear they are fitted on the side of the body behind the rear axle. Their design and functional principle largely corresponds to that of the wheel acceleration senders. They are also connected to the running gear control unit via a PS15 two-wire bus. In this case, the signal is transmitted at 60 Hz; the measurement range is approx. ± 1.6 g.

No further activities (calibration etc.) are required after a body acceleration sender is replaced in service.

As with the wheel acceleration senders, it is possible to check whether the sender is fundamentally working properly by tipping it 180° out of its normal installation position. If the sender is working correctly and the wiring is intact, negative actual values will be displayed as measured values.

Position of body acceleration sender in area of front axle



684_191

Position of body acceleration sender in area of rear axle

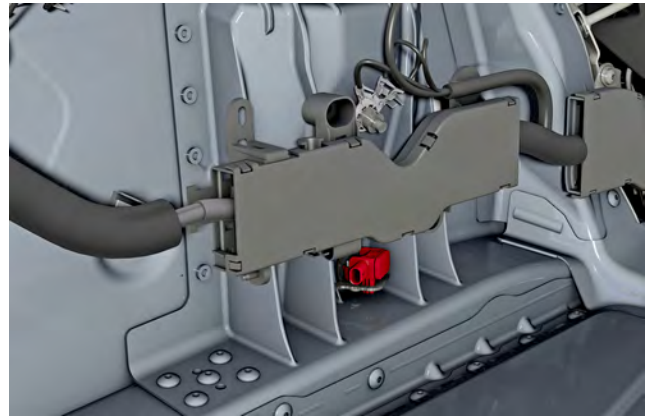

684_193

Air lines, line connections, line connectors

The air lines which connect the air supply unit (solenoid valve block) to the air springs are fitted in the electrical wiring harness. The air line to the accumulator is a moulding. Repairs to the air line system are also defined for the Audi e-tron GT. They largely correspond to those undertaken for other Audi models.



Note

Please note the information in the Workshop Manual.

How the system works

The general function of the entire system (generating and dissipating pressure, boost function, integration of accumulator in regulating processes, actuation of solenoid valves, pressure measurements) corresponds to that of the adaptive air suspension in the Audi Q7 (type 4M).



Reference

For further information, please refer to (refer to chapter "Chassis with air suspension and electronic damper control (adaptive air suspension)") in SSP 633 "Audi Q7 (type 4M) Chassis."

The main new feature is the introduction of the three-chamber air springs. Their functions and the resulting benefits are described in the "System components" chapter. Integrating the wheel acceleration sensors in the entire system for the first time increases precision when detecting the vehicle dynamics. The development aim was to retain the familiar operating and display concept from other Audi models with adaptive air suspension. The desired mode can also be selected in Audi drive select on the Audi e-tron GT. The modes have been specially defined and applied to the Audi e-tron GT.

Regulating characteristics

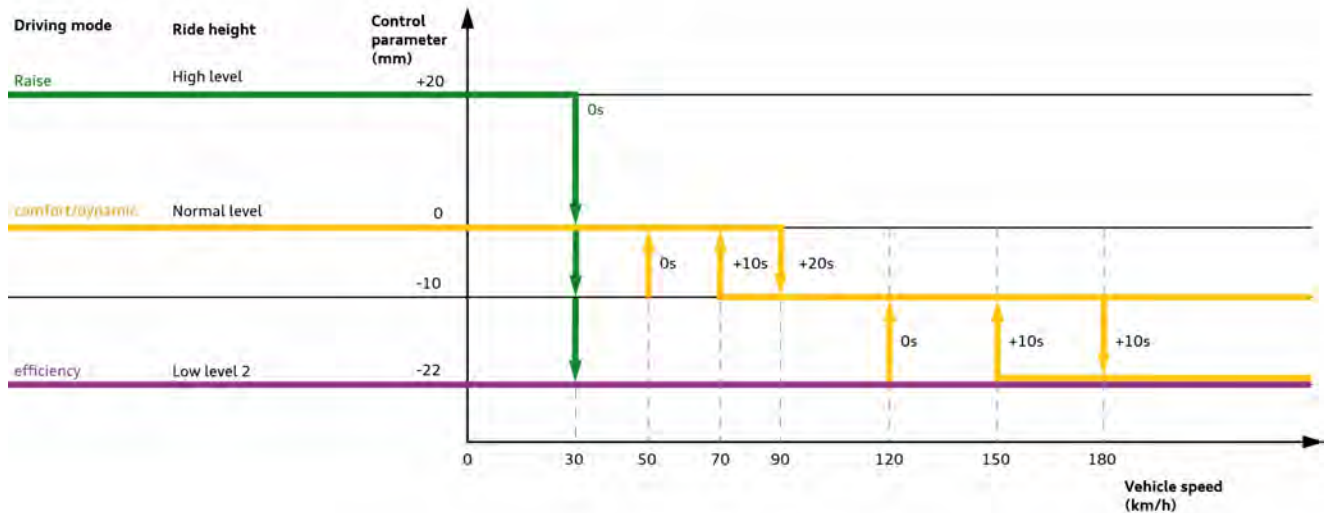

684_390

Various adaptive air suspension regulating characteristic maps are activated depending on the setting selected in Audi drive select. Every mode has a defined vehicle level when the vehicle is stationary and a corresponding damper characteristic map. Automatic changes to the levels are initiated by the regulation depending on the vehicle speed.

The different drive select settings correspond to three different vehicle levels. Every new driving cycle starts in “comfort” mode automatically. If “Raise” mode is selected, the highest vehicle level is set (+20 mm compared to normal level).

The high level is ended automatically at 30 km/h and above. The vehicle is then lowered to the level of the previously selected mode. In “comfort” and “dynamic” modes, the level is lowered by 10 mm if the vehicle speed exceeds 90 km/h for a period of 20 seconds. If the speed subsequently drops below 70 km/h for a period of 10 seconds, the vehicle is raised to the initial level of “comfort/dynamic” mode. If the speed drops below 50 km/h, the vehicle is raised to this level immediately without a time delay. If the vehicle speed exceeds 180 km/h for a period of 10 seconds, the level is lowered by 22 mm. If the speed is subsequently reduced to under 150 km/h for 10 seconds, the original level is restored. If the speed exceeds 120 km/h, the vehicle is raised to lower level 1 immediately without a time delay. The aim of these automatic level reductions is, alongside increased driving stability, to reduce air turbulence under the vehicle and in the wheel housings. Improving the aerodynamics positively affects the drive power required and therefore also increases the range. This is the reason why low level 2 (-22 mm compared to “normal” level) is activated when “efficiency” mode is selected.

It is only possible to lower the level when the vehicle is stationary if all four doors are closed. When the vehicle is parked (after bus sleep mode), a one-off check of the vehicle level is made after eight hours by evaluating the measured values from the vehicle level senders. If the accumulator pressure is sufficient, the vehicle is raised (if necessary) using the accumulator only (the compressor does not run).

Electronic damping control

Electronic damping control with steel springs is standard equipment on the Audi e-tron GT. The system’s design and functions fundamentally correspond to those of the systems used in other Audi models. A new feature is that the acceleration of unsprung masses can be detected by four separate sensors. Single-tube dampers with inner regulating valves are used. The running gear control unit J775 remains the control centre on the Audi e-tron GT.

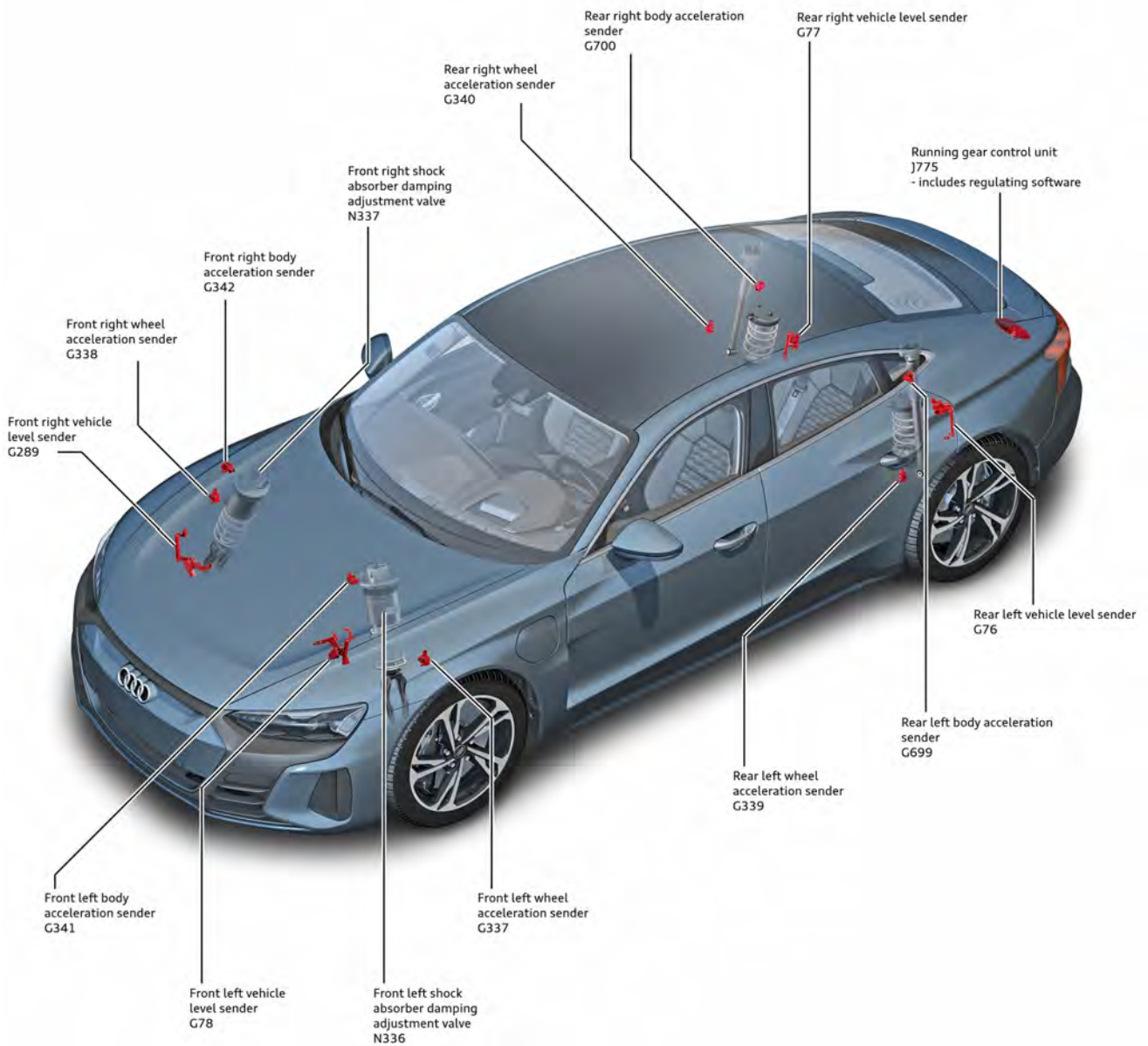

684_434

The driver can specify the damping characteristics via the drive select setting selected.

System faults are shown via the familiar yellow warning symbol and a driver message.



The service operations are the same as for the systems which are already used on other Audi models for damping control. The same sensors (vehicle level senders, body acceleration senders, wheel acceleration senders) as on the adaptive air suspension are used. The information on these sensors in the adaptive air suspension chapter also applies to the electronic damping control.

Steering system

Overview

Electromechanical power steering is used for the steering system of the Audi e-tron GT. Steering assistance is provided by a synchronous electric motor fitted parallel to the axle. Manual adjustment for the steering column is included in the standard equipment. An electrically adjustable steering column is available as an optional extra. Four-wheel steering is available as optional equipment for the Audi e-tron GT. Three-spoke leather sport steering wheels are standard equipment.

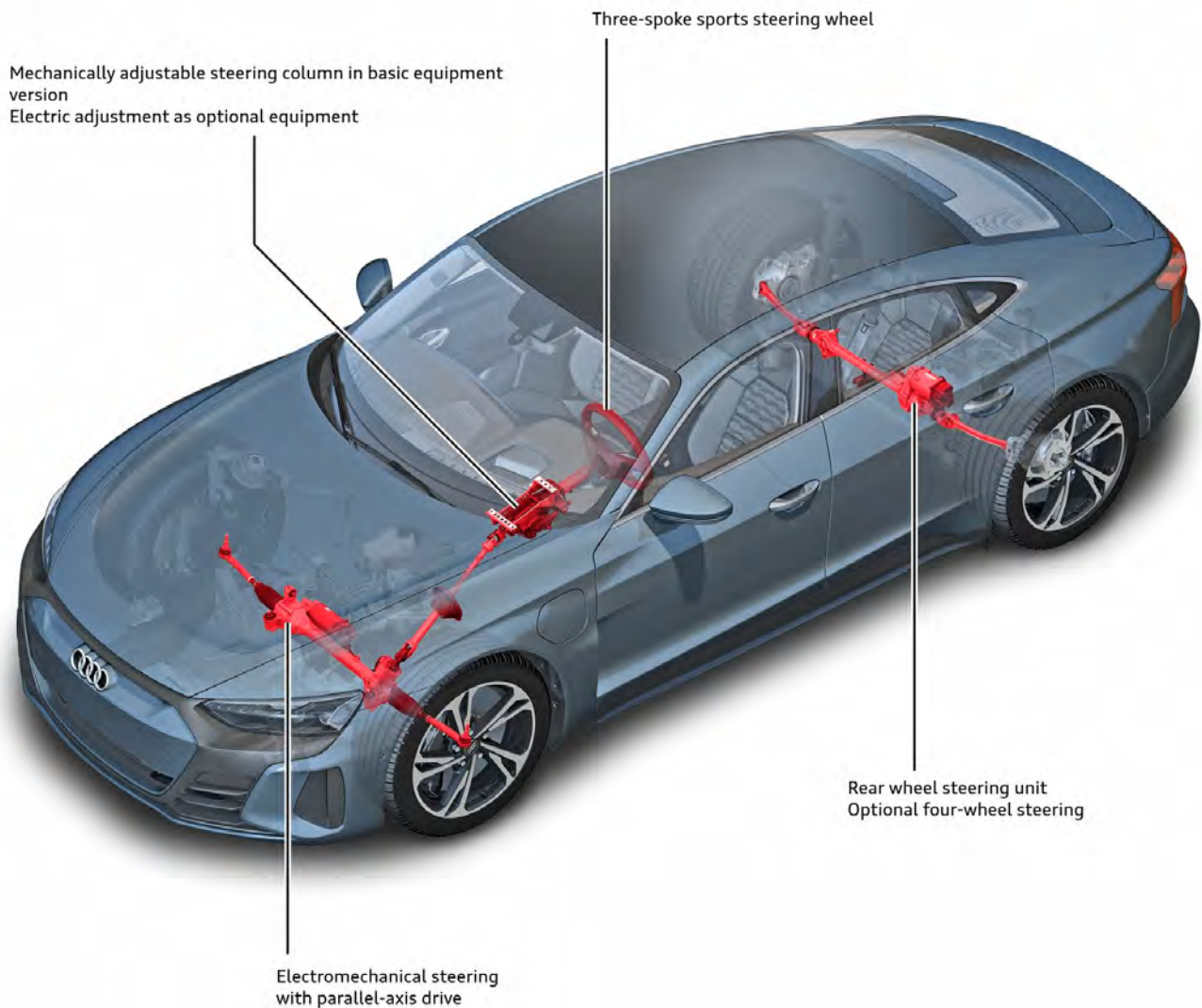

684_253

Electromechanical power steering system (EPS)

Design and function

In terms of design, operation and servicing operations, the EPS on the Audi e-tron GT corresponds to that used on other Audi models equipped with this steering system.



Reference

Information on the construction and function can also be found in SSP 644 "Audi A4 (type 8W)" (refer to article "Steering system").

Steering assistance is provided by a synchronous electric motor fitted parallel to the axle. The motor's torque is transmitted to a ball screw drive via a toothed belt and sent to the steering rack as axial force.

The power steering control unit J500 communicates via FlexRay channel A.

The main basic information for calculating the steering assistance consists of the steering torque which the driver introduces via the steering wheel, the vehicle speed and the steering angle. The steering torque is transmitted to the control unit via a discrete wire by the steering moment sender G269 contained in the module. The vehicle speed and steering angle are sent using FlexRay via the ABS control unit J104. Two temperature sensors monitor the temperature of the control unit and that of the output stages. The output stages provide the current to activate the motor while also taking the rotor position of the synchronous electric motor into account. The control unit receives the information on the rotor position from within the module. It comes from a rotor position sender in the electric motor.

The steering assistance is activated after the vehicle is started (terminal 15 on) and the drive system is activated.

The additional functions familiar from other Audi models, such as assist-based steering impulses (driver steering recommendation - DSR), "software" end stops and active steering resets have also been implemented on the Audi e-tron GT.

The EPS unit is fitted on the subframe behind the front axle. The module consists of the steering rack, the electric motor with toothed belt and ball screw drive, the power steering control unit J500, the steering moment sender and the track rods and boots.



684_432

Schematic diagram

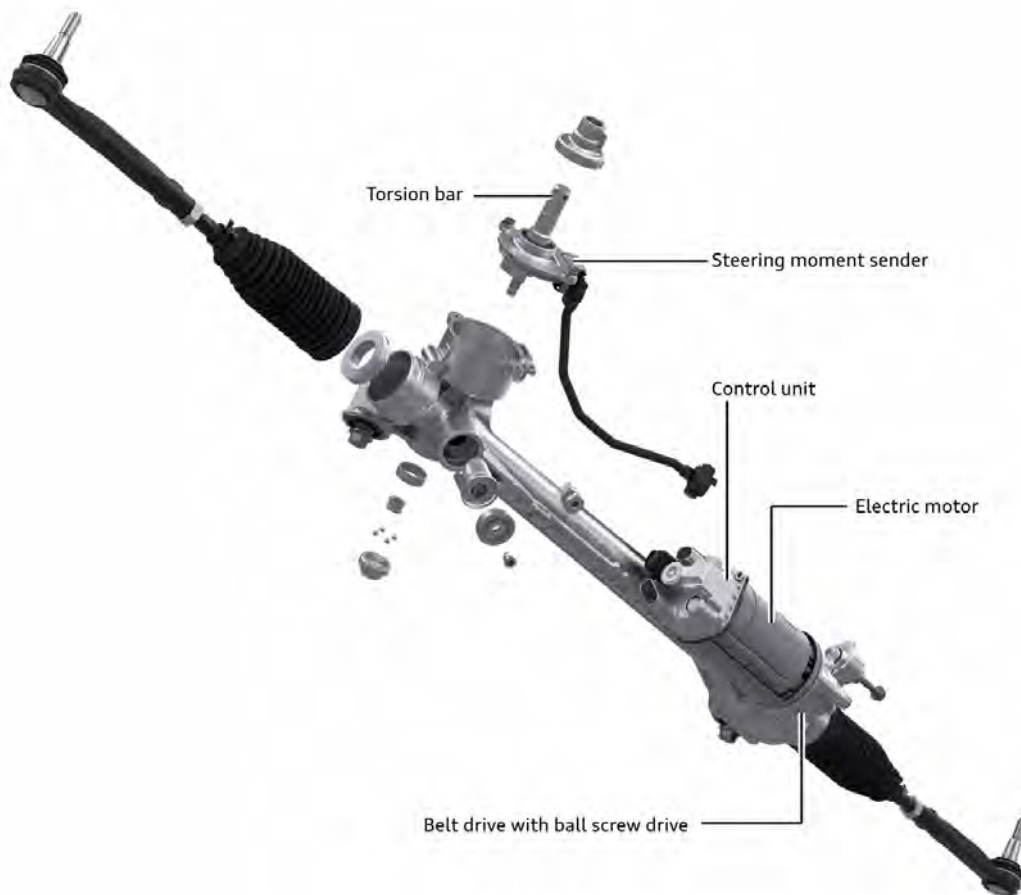

684_433

Response in the event of a fault

As on other Audi models, detected faults are indicated via the activation of the steering wheel symbol and explanatory messages. Depending on the relevance, the symbol is shown in either yellow or red. The relevant messages are described in the Owner's Manual.



Service operations

The track rods and boots can be replaced separately in service.

After replacing the module and coding the control unit online, the maximum steering wheel angles must be adapted and the steering angle sender G85 must be calibrated.

Steering column

Manual adjustment for the steering column is included in the standard equipment. An electrically adjustable steering column is available as an optional extra.



684_246

Steering wheel

Three-spoke leather sport steering wheels with flattened rims are used. The standard Audi e-tron GT steering wheel is perforated in the grip area. All steering wheels are equipped with one of two versions of recuperation paddle levers. The standard steering wheel of the RS model is equipped, as with all other optional steering wheels (except the Alcantara equipment option), with a fully perforated rim. The RS logo is also affixed to the RS model's steering wheels. It is located under the opening of the centre spoke. Steering wheel heating is optional equipment for the Audi e-tron GT; it is standard equipment for the RS model.



Standard equipment for Audi e-tron GT with full leather steering wheel rim (perforated in grip area) and small paddle levers



Standard equipment for RS e-tron GT with full perforated leather steering wheel rim, large paddle levers, steering wheel heating and RS logo

All steering wheels have paddle levers for the driver to select the level of recuperation in overrun mode. The optional steering wheels for the Audi e-tron GT and both steering wheels (standard and optional) for the RS model are equipped with large paddle levers made of aluminum.

The operating logic from vehicles with conventional drive systems has been used (as on the Audi e-tron):

When the (-) paddle lever is operated, the vehicle is decelerated by shifting down in overrun mode. The Audi e-tron GT decelerates when the electric motor recuperates energy while it is in generator mode. The driver can increase/reduce the level of recuperation in stages using the (+) or (-) paddle lever respectively. The menu option for manual recuperation must be set in the MMI to do this. Two recuperation levels can be selected.

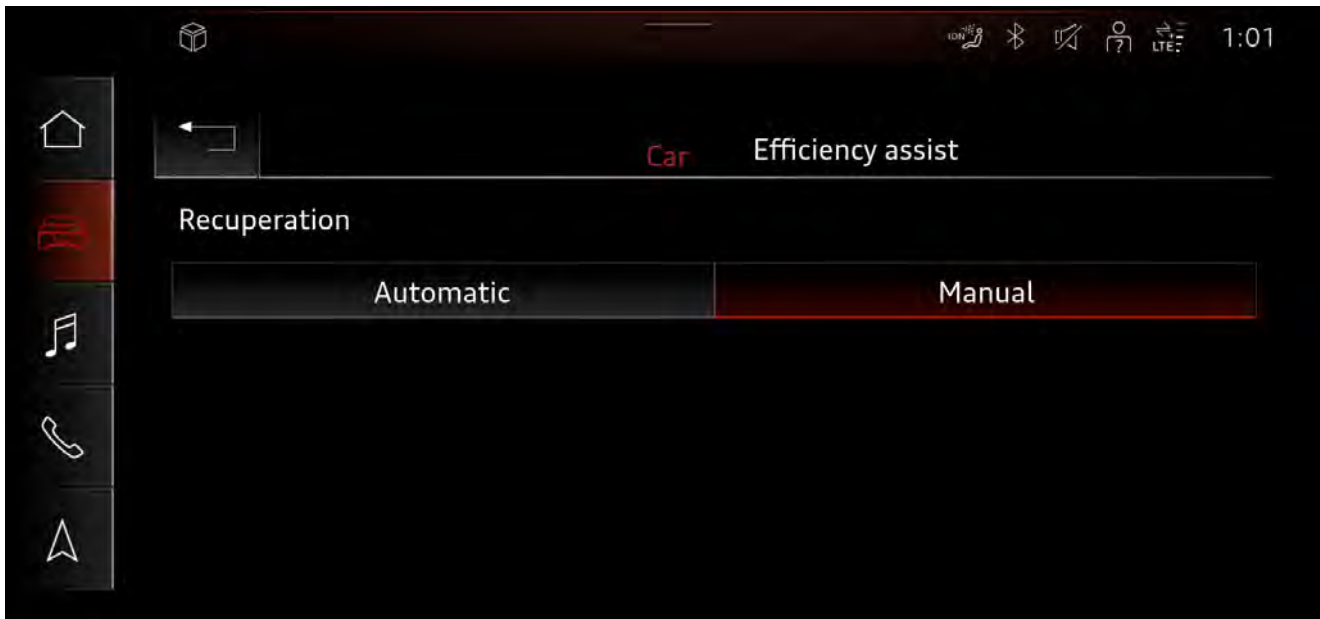

684_249

Four-wheel steering

Four-wheel steering was first used in the Audi Q7 (type 4M). Four-wheel steering is available as optional equipment for the Audi e-tron GT.

In terms of design (components), functions and servicing requirements, the four-wheel steering system corresponds to that used on the Audi Q7 (type 4M).



Reference

For further information, please refer to (refer to chapter "Chassis with air suspension and electronic damper control (adaptive air suspension)") in SSP 633 "Audi Q7 (type 4M) Chassis."

The rear axle steering rack also works in the same way as the one on the Audi Q7. The electric motor drives the spindle nut via the drive belt. The rotational movement of the spindle nut is converted to linear movement of the spindle. The connected track rods transmit the linear motion to the hub carriers and the wheels are steered in the same direction to the right or left (depending on the direction of rotation of the electric motor). The system is self-locking due to the transmission ratio and the trapezoidal thread of the spindle and the spindle nut.

The maximum wheel steering angle on the rear axle is 2.8° (approx. 5° on Audi A8 (type 4N) and Audi Q7 (type 4M)).

Brake system

Overview

Newly developed brake systems are used on the Audi e-tron GT and the RS model. The Audi e-tron GT has conventional brake discs as standard equipment in conjunction with 6-piston fixed caliper brakes on the front axle and 4-piston fixed caliper brakes on the rear axle. Brake discs with a tungsten carbide coating (PSCB) are being used on an Audi model for the first time. This brake system is standard equipment for the Audi RS e-tron GT and is available as optional equipment for the Audi e-tron GT.

Ceramic brakes are available as optional equipment for both e-tron GT models. The brake calipers for the PSCB and ceramic brake system are available in different colours. The front and rear brakes have separate brake circuits. About 65 % of the braking force is transmitted at the front axle and about 35 % at the rear axle.

For the first time on an Audi model, the electromechanical parking brake on the rear axle is a drum brake. The brake drum is formed by the hub of the brake disc. As on other Audi models, the regulating software for the parking brake is in the ESC control unit.

To ensure that the requirements that the electric drive system makes of the brake system (brake blending, recuperation etc.) are met, an electromechanical brake servo is fitted on the Audi e-tron GT in conjunction with a powerful ESC system of generation 9.2. These systems make autonomous braking maneuvers independent of the driver possible.

The components and dimensions of the brake system may vary from those shown in the overview in some markets in order to conform to country-specific regulations.

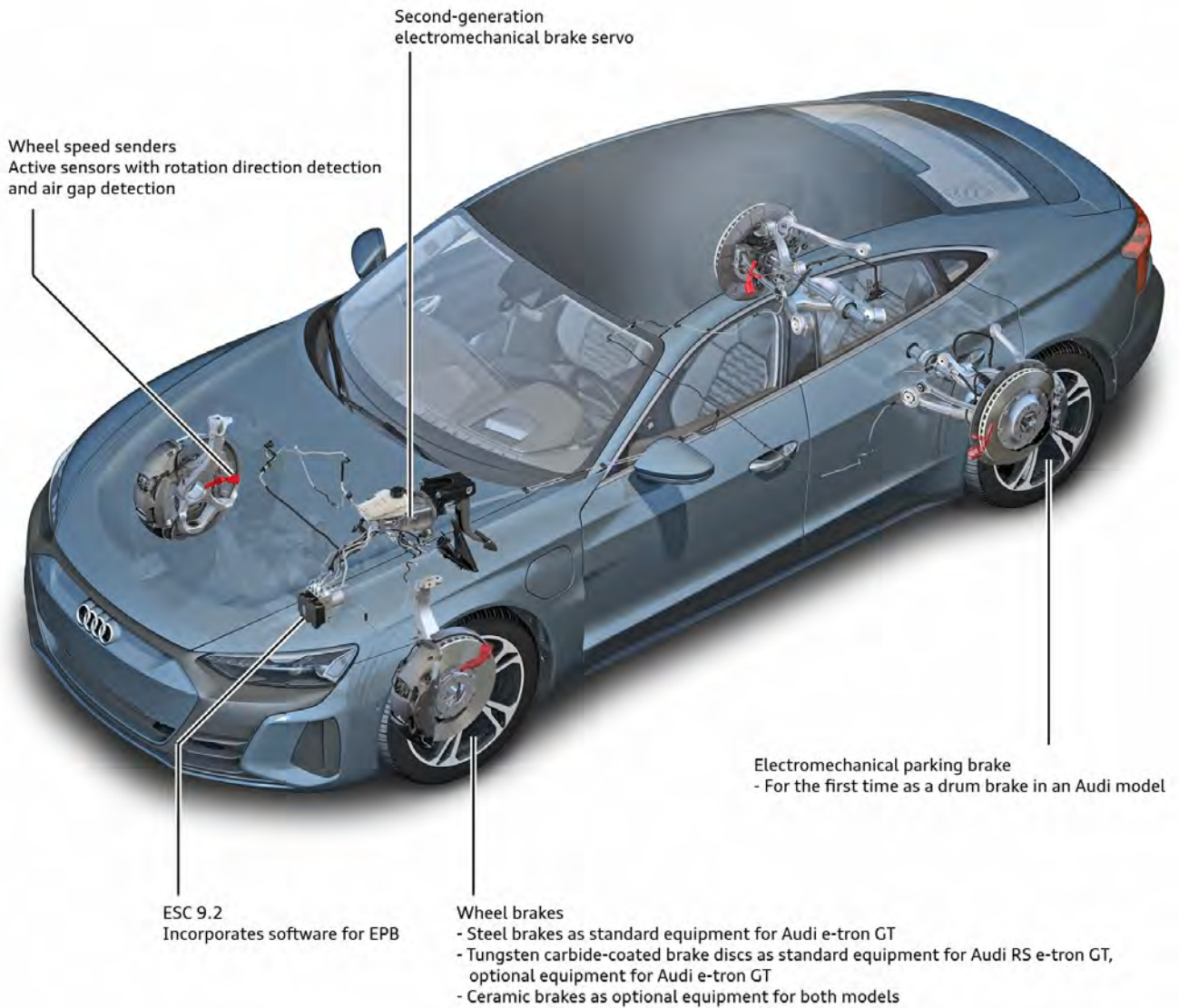

684_251

Brake system

Type of brakes	Front axle	Rear axle
Conventional brake system	6-piston fixed caliper brakes	4-piston fixed caliper brakes
Standard equipment for Audi e-tron GT	Cast iron brake discs 360 x 30 mm	Cast iron brake discs 358 x 28 mm
Steel brake with tungsten carbide coating	6-piston fixed caliper brakes	4-piston fixed caliper brakes
Standard equipment for Audi RS e-tron GT, optional equipment for Audi e-tron GT	Brake discs with tungsten carbide coating 410 x 38 mm Special brake pads	Brake discs with tungsten carbide coating 365 x 28 mm Special brake pads
Ceramic brake system	10-piston fixed caliper brakes	4-piston fixed caliper brakes
Optional equipment for both models	Ceramic brake discs 420 x 40 mm Special brake pads	Ceramic brake discs 410 x 32 mm Special brake pads

All four wheels are equipped with brake pad wear detection.

Steel brake with tungsten carbide coating

This brake system is being used on an Audi model for the first time. It was developed by Porsche AG and has already been successfully used on some Porsche models. The main difference compared to conventional brake systems is the coating on the friction surfaces of the brake discs, which are cast iron composite brake discs. The friction surfaces have two coatings. First, an galvanic nickel coating of approx. 10 micrometres is applied to the cast iron base plate. This coating is designed to inhibit cracks and provide corrosion resistance. The actual tungsten carbide friction coating of approx. 40 - 200 micrometres is applied to the nickel layer. Tungsten carbide is a ceramic material which is added to many different hard metals. It is mainly used in toolmaking for components and tools which need to be particularly wear-resistant.

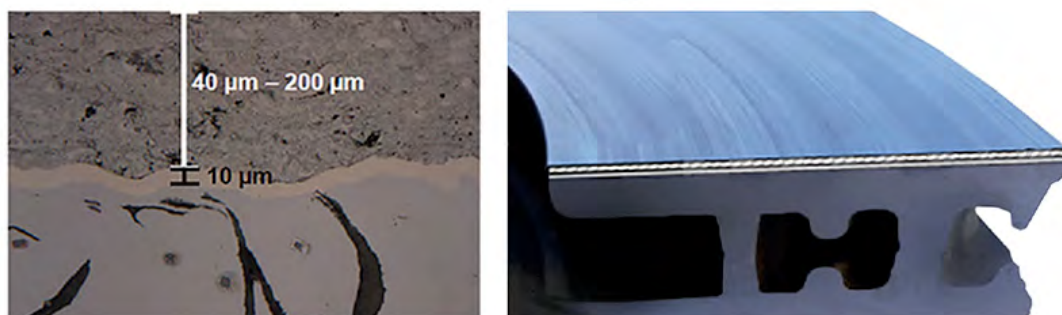

684_343

The following characteristics of the brake discs single them out in particular:

- › **High corrosion resistance**
Because of the high level of recuperation under braking, the hydraulic service brakes are used significantly less than on vehicles with conventional drive systems. As a result, corrosion resistance is very important, both functionally and from the perspective of the visual impression given by the vehicle.
- › **Large wear resistance**
Compared to a conventional brake disc, the service life is approx. 30 % longer.
- › **Better performance**
Thanks to the friction torque being built up quickly, the response is better than that of a conventional brake disc. The friction remains more stable during a braking procedure. As a result, the feared brake fade (a decrease in the braking efficiency at very high brake temperatures) is reduced significantly.

Specially developed brake pads have been used to be able to make the best use of the positive characteristics of the brake discs.

Steel brake with tungsten carbide coating – 6-piston fixed caliper on front axle



684_409

Ceramic brake with 10-piston fixed caliper on front axle



684_410

Electromechanical brake servo

Overview

With its electric drive, the normal requirements for achieving the braking function both without recuperation and at different levels of recuperation also apply to the Audi e-tron GT. Based on previous experience, the driver expects a braking effect which corresponds to the pressure placed on the brake pedal. Depending on the recuperation taking place and the braking power being provided by the electric drive motor(s), the “remaining” braking effect must be provided by the hydraulic brake system. This is not possible with a conventional pneumatic brake servo with a fixed ratio of pedal force to piston rod force of the brake master cylinder. These complex requirements can only be met by an electromechanical brake servo.

The electromechanical brake servo is able to induce brake pressure independently of the driver. When recuperation is taking place, the hydraulic brake pressure can be restricted to the level required. Alternatively, brake pressure can be generated actively without being initiated by the driver if other systems request it (e.g. adaptive cruise assist/ACC).

Design and function

This complex module consists of brake servo control unit J539, a two-stage gear drive, an electric motor to drive the gearing, a distance sensor and the coupling rod which connects to the brake pedal.



684_168



684_272

Excepting the gearing technology used, the design and functions of the second generation electromechanical brake servo correspond to those of the systems already in use on other Audi models.



Reference

Further information on how an electromechanical brake servo works can be found in Service TV programme 0413 TV "A3 Sportback e-tron - Electromechanical Brake Servo".

The brake servo on the Audi e-tron GT works on the basis of a two-stage gear drive driven by an electric motor. The output of the gear drive is a spindle shaft. When the brake servo is active, the rotational movement of the spindle shaft is converted into a longitudinal movement of the spindle nut on the shaft. The spindle nut is in contact with a thrust piece which moves longitudinally and passes the force on to a reaction plate. The force initiated by the driver via the brake pedal is also applied to this reaction plate by the piston rod. The reaction plate operates the piston rod of the brake master cylinder, thereby generating brake pressure. The two forces work independently of each other. The activation of the electric motor allows brake pressure to be generated even if the driver does not press the brake pedal. A sensor designed on the principle of redundancy (brake pedal position sender G100, brake pedal position sender 2 G836) detects the pedal travel initiated by the driver. In doing this, the control unit calculates the braking torque desired by the driver and the amount of braking assistance required.

If other systems (e.g. deceleration request by the adaptive cruise assist) require that brake pressure be generated autonomously, control unit J539 receives the message requesting implementation from ABS control unit J104.

Active accumulator VX70 used on the Audi Q7 e-tron and A3 e-tron vehicles is not fitted on the e-tron GT. The accumulator's function is assumed by the ESC.

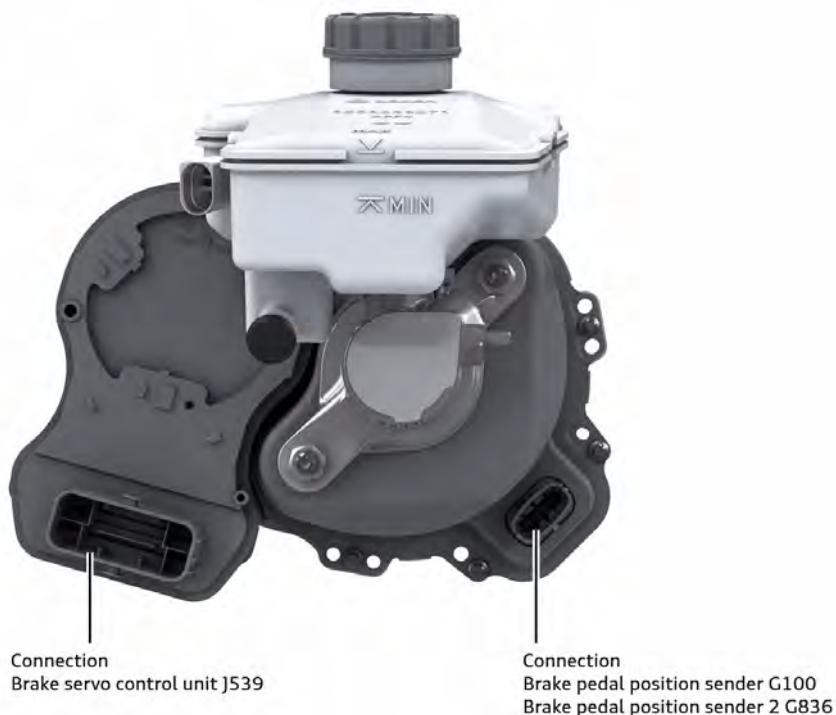

684_411

Run-on – behaviour when terminal 15 is off

As on a conventional brake servo, the boosting function of the brake servo remains available for a certain period after terminal 15 has been switched off. While the pressure is fully dissipated within a few braking procedures on vehicles with pneumatic brake servo and conventional drive system, it remains fully available on the Audi e-tron GT for a defined period.

The procedure depends on whether the driver is pressing the brake pedal at the moment terminal 15 is switched off or not.

If the driver is pressing the brake pedal, the brake servo remains fully available for 60 seconds. In the following 120 seconds, the brake servo is then reduced until it is fully switched off.

If the driver is not pressing the brake pedal, the brake servo remains fully available for 60 seconds and is then switched off.

System behaviour in the event of a fault

If the electromechanical brake servo fails, the ESC steps in to generate the brake pressure required. The brake pressure generated by the driver's pedal application is boosted accordingly. This condition is shown by the yellow warning lamp.



If the ESC is also not available, other functions in addition to the brake servo will not be available. The loss of the electronic brake pressure distribution is particularly critical here, as this can lead to the rear axle being "overbraked" with a corresponding loss of stability. For this reason, this condition is indicated by the red brake warning lamp and a driver message.

Service operations

The electromechanical brake servo must be replaced as a complete module. There is no provision for separating the mechanical unit and the control unit in after-sales service. The Guided Function "0023 - Replace control unit" must be started before the part is replaced. After the control unit has been coded online, a functional check (0023 - Brake booster / function test) is performed as part of this function. If necessary (if the pressure check performed as part of the functional check returns a negative result), the brake system must be bled according to the specifications in the Workshop Manual

The functional check should then be repeated. If the pressure test returns a negative result again, the Guided Functions "023 - eBKV bleed brakes" and "003 - Service bleeding" must be performed. The final check is carried out in a concluding functional check.

This functional check verifies that the brake pedal is in the correct position (zero position) when it is not pressed. Pressure is then built up actively, the position of the input rod is checked by the pedal travel sensor and the brake pressure level reached is checked by the pressure sensor for the pressure in the ESC hydraulic unit.

ESC 9.2

Overview

The ESC of generation 9.2 is used on the Audi e-tron GT. The control unit and the hydraulic unit are combined as one unit. As in various other Audi models (A6, A7, A8, Q7, Q8), a 6-piston pump (3 pistons per brake circuit) generates the necessary brake pressure. The benefits of this design are that pressure can be generated more quickly, the pressure curves remain consistent, and the acoustics are improved (fewer noises).

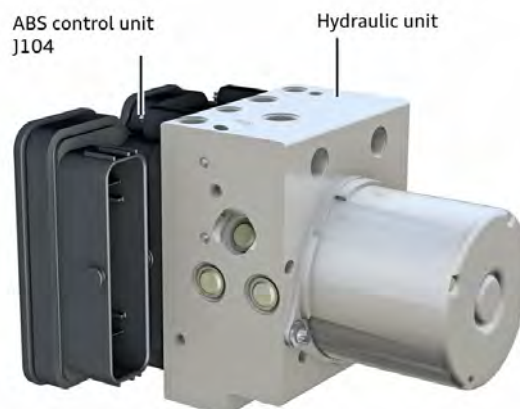

684_167

ABS control unit J104

The control unit is connected to both FlexRay channels (A and B). The control unit processes the following main input signals:

- › Wheel speeds – the wheel speed senders are connected directly via discrete wires

- › Longitudinal acceleration, lateral acceleration and yaw rate – via FlexRay from airbag control unit
- › Brake pressure – internal wiring to three pressure sensors integrated in the hydraulic unit
- › Steering angle – via FlexRay from steering angle sender G85 (part of steering column electronics control unit J527)
- › Motor torques – via FlexRay from motor control unit J623

On the basis of the data received, the control unit determines the wheel slip values in relation to the relevant driving state. If it detects that regulation is required, it activates the control elements (solenoid valves and electric motor for pump units). It also triggers the driver information displays required.

The software for activating the electromechanical parking brake is also included in the control unit.



Reference

For further information, please refer to SSP 475 "Audi ESC systems".

A new feature is a refresh routine to maintain the friction contact between the brake pad and the brake disc and prevent corrosion, even when the vehicle is parked for a long time. The reason for this is the relatively low amount of time that the service brakes are used for. Thanks to the use of recuperation to decelerate the vehicle, a mere 20 % of braking procedures now use the service brakes, on average. The refresh routine is activated automatically after the vehicle has been stationary for at least six hours. In this situation, the recuperation is temporarily deactivated in the next driving cycle and the service brakes are activated instead. Active brake pressure is generated by the ESC to do this for as long as it takes to generate a defined amount of braking energy.

Hydraulic unit

As on other Audi models with ACC/adaptive cruise assist, the hydraulic unit contains six pump units, the electric motor for the pump drive, the solenoid valves/switching valves, reservoirs and three pressure sensors. The construction and functions/switching positions of the valves for the functions to generate, maintain and dissipate pressure fundamentally correspond to those of the systems already in use. Large reservoirs ensure that pressure is dissipated very quickly in the first start-up phase of the return flow pump.



Reference

For further information, please refer to SSP 475 "Audi ESC systems".

A pressure sensor permanently measures the pressure in the system (at the brake master cylinder output/the input of the hydraulic unit). The pressure in the brake circuits (one on each axle) is measured by two additional sensors. As a result, it is possible to regulate the pressures at the wheel brakes very precisely so that brake blending can be achieved without the driver noticing the transitions.

Operation and driver information

The ESC can be switched off by holding the corresponding button in the centre console for more than three seconds. This deactivates traction control inputs and braking interventions on individual wheels. The system remains switched off during the current terminal 15 cycle or until it is reactivated when the button is pressed again. The driver is informed of the deactivation via a message on the display and the activation of the ESC OFF symbol.

ESC OFF



683_344

If system faults or malfunctions of certain other systems (e.g. adaptive air suspension, four-wheel drive, axle differential lock) are diagnosed while the ESC is deactivated, the ESC is reactivated. This cannot be overridden. The ESC is switched on automatically every time the drive system is switched on (terminal 15 on).

The warning lamps for ABS/EDL, ESC, brakes, brake pad wear and parking brake (sometimes in conjunction with driver messages) are activated by ABS control unit J104.



Wheel speed senders

Active Hall senders are used which can also detect the direction of travel. The senders are directly connected to control unit J104 via two wires each. One wire is for power supply, the other is the signal wire. The earth connection is achieved by the bolted connection between the sender and the wheel bearing housing/hub carrier. The sender module contains an electronic switch which converts the analogue sensor signals into digital signals. Current signals are transmitted to the control unit. In addition to the frequency (speed), they also include the direction of rotation, whether the vehicle is stationary, and the size of the air gap between the sensor and the impulse ring. The size of the air gap is an important criterion for system diagnosis. If the vehicle's drive system is activated (terminal 15 on), the sensors are briefly supplied with current (self-test performed). The senders are supplied with power when the drive system is activated; the power supply remains in place until the vehicle comes to a stop or the drive system is deactivated.

Magnetised impulse rings are integrated in the wheel bearing seals as impulse senders (48 north/south poles).



684_248

Electromechanical parking brake (EPB)

Overview

A drum brake is used for the electromechanical parking brake on an Audi model for the first time on the Audi e-tron GT. The brake system is a duo-servo brake system. The main benefit of this design is the identical braking effect when the vehicle is travelling forwards or backwards. The inner end faces of the brake disc hubs provide the friction surfaces for the brake pads. The parking brake and the service brakes are two separate systems. As is usual on Audi models, the electromechanical parking brake is operated via a button in the centre console. The activation and regulation software is integrated in ABS control unit J104.

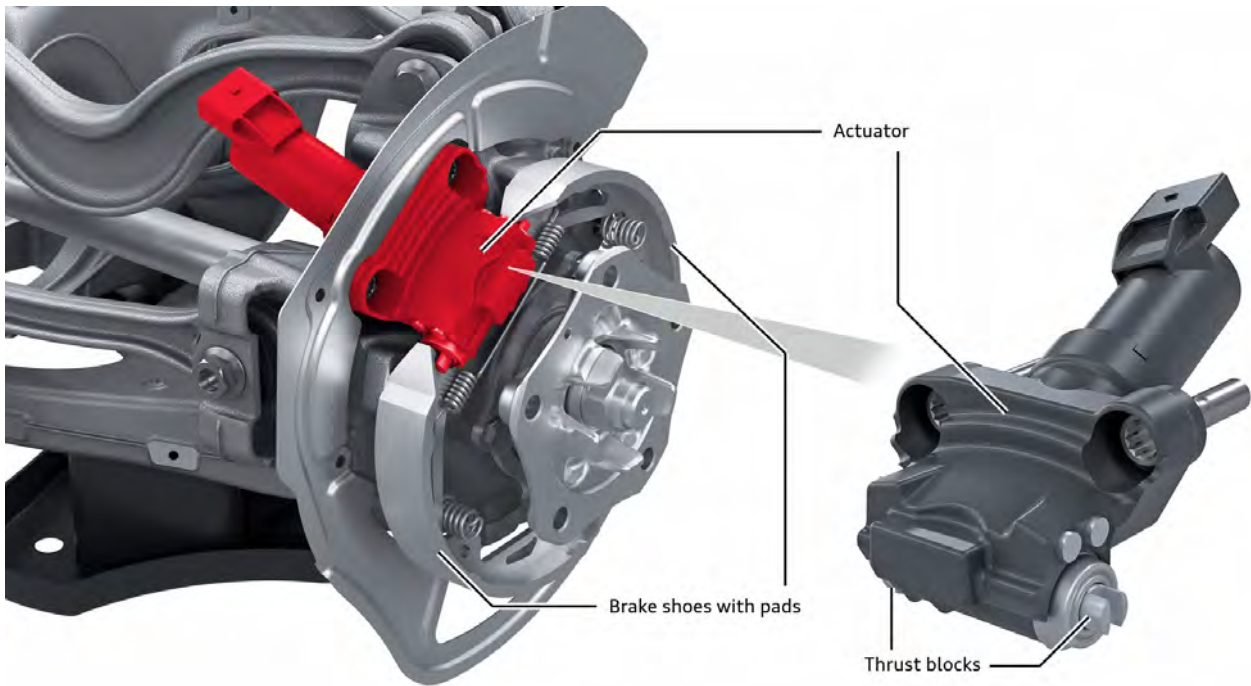

684_419

Design and function

The brake shoes support themselves on one side against one of the actuator's two thrust pieces. On the other side, they make contact with the adjustment mechanism on both sides. Two extension springs hold them in this position. The adjustment mechanism is in a floating bearing arrangement and moves longitudinally. When forces are applied from the side by the brake shoes, the position of the adjustment mechanism changes (longitudinal adjustment) depending on the amount of force applied. This technical design achieves a duo-servo function. The servo function (self-boosting) results when, after being operated by the actuator's thrust piece, the brake shoe in this area first makes contact with the drum and, when it does so, applies a force (pressure) to the adjustment mechanism at its other bearing position. The adjustment mechanism is moved towards the other brake shoe, which causes this brake shoe to make contact with the brake drum. Both brake shoes are therefore the leading brake shoes for the brake drum. If the brake shoes are mounted in a bearing arrangement on an adjustment mechanism which is fixed in position, there is no self-boosting; one brake shoe leads and the other trails. The duo-servo function is achieved in that the actuator's thrust pieces operate both brake shoes. This means that the servo function is effective in both directions of travel (forwards and backwards).

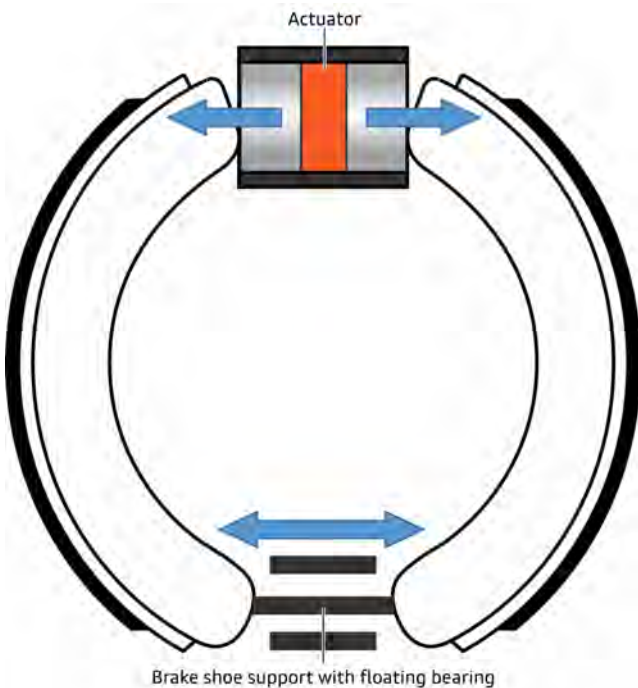

684_408

When the parking brake is engaged, both thrust pieces are moved outwards against the brake shoes. When it is released, the thrust pieces move inwards towards each other. When the parking brake is released, the brake shoes centralise themselves automatically thanks to their floating bearing arrangement in the area of the adjustment mechanism. To determine the exact position of the thrust pieces, the rotational movement of the electric motor is determined by an internal sensor. Two separate wires transmit the sensor signal to ABS control unit J104 and two additional wires are used to activate the electric motor.

Operation and driver information

Engaging the parking brake

On the Audi e-tron GT, the parking brake is again activated by the electromechanical parking brake button E538 in the centre console. As on all Audi models, the activated electromechanical parking brake is indicated by a parking brake symbol on the display. Transmission position P (parking lock) is activated automatically when the parking brake is engaged with the vehicle stationary.

The parking brake can be activated at speeds < approx. 2 km/h. In this case, the vehicle is brought to a standstill by the parking brake, and the parking lock is then only activated when the vehicle is stationary.

Releasing the parking brake

The parking brake is automatically released when the drive system is activated (transmission position D or R selected) and the accelerator pedal is pressed. For this to happen, the driver's door must be closed and the driver's seat belt must be buckled. If the vehicle is on a gradient of more than five degrees, it only moves off when the drive torque is sufficient to prevent the vehicle from rolling back in the other direction.

Engaging and disengaging independently of the parking lock

The parking brake can also be manually engaged and disengaged independently of the parking lock when the vehicle is stationary via a setting in the MMI.



684_048

Emergency braking function

As on other Audi models, the electromechanical parking brake on the Audi e-tron GT can also be used for emergency braking in dangerous situations. The vehicle must be travelling at a speed of > approx. 3.5 km/h to do this. The button must remain pressed for the intended duration of the braking procedure and the accelerator pedal must not be pressed. An additional acoustic warning signal is activated for the duration of the braking procedure.

Engaging manually

The condition for the functions described is that there is at least one valid wheel speed signal per axle. If this condition is not met, the parking brake can still be engaged to park the vehicle. To do this, the switch must be operated for longer than 10 seconds with terminal 15 switched off.

Additional functions

Automatic re-tensioning

To ensure that a defined retaining force is provided, the system is re-tensioned on parked vehicles after they have been stationary for a specified period.

Automatic detection of brake test dynamometer

If the wheels on one axle are stationary and those on the other axle are turning, the system detects that a test is taking place and switches to the corresponding mode. If the wheels on the front axle are being driven by the roller, the parking brake is engaged. If the wheels on the rear axle are being driven, the parking brake remains disengaged. This allows the service brakes to be tested as usual. The electromechanical parking brake test corresponds to the emergency braking procedure.

Integration of hydraulic brake system in vehicle's recuperation system

A braking procedure initiated by the driver can be achieved 100 % hydraulically, 100 % electrically or using a mix of the vehicle's hydraulic and electric braking power. The main conditions for recuperation are the ability of the battery to take in electric energy, a dynamic driving state suitable for recuperation and a suitable vehicle speed. As a result, the system predominantly generates hydraulic brake pressure in corners as it is more likely that stabilising brake inputs (ESC regulation) will be needed. Regulation on specific wheels can only be performed by the hydraulic brake system. Even if each wheel were driven by a separate electric motor, the regulation of the electric motors would not be fast enough. Hydraulic brake pressure is also generated under braking at low vehicle speeds in addition to recuperation. This ensures that the vehicle can be brought to a standstill safely. Autonomous braking procedures (e.g. by the adaptive cruise assist, stop and go) are also supported by the ESC in conjunction with the electromechanical brake servo. If braking procedures are required by/for assist systems where there is a certain level of danger potential (e.g. in emergency braking procedures), any recuperation currently in progress is switched to a fully hydraulic braking procedure.

To ensure that the battery has a good level of charge and by extension a large range, the system recuperates energy as often as possible. This also means that braking procedures with low to medium vehicle decelerations (up to approx. 3 m/s^2) are usually performed electrically. The driver will not be able to tell whether the braking procedure which he/she has initiated is being implemented electrically, hydraulically or as a mix of the two.

The decision as to which system contributes to what extent to providing the necessary braking torque is complex. Running gear control unit J775, ABS control unit J104 and motor control unit J623 are primarily involved. The motor control unit permanently transmits information on the current maximum recuperation capacity/braking power to the ABS control unit. If the driver presses the brake pedal or an assist system (e.g. adaptive cruise assist) requests braking deceleration, the ABS control unit determines whether the braking procedure required can be performed fully electrically via recuperation or whether additional hydraulic braking power needs to be provided. It transmits the specified generator torque to the motor control unit. This is the amount of braking power required from recuperation. At the same time, it sends a message to the running gear control unit with the calculated "ideal" distribution of the braking torque on the front and rear axle. As the running gear control unit is continuously determining the current dynamic driving state, it coordinates the transition between acceleration and overrun recuperation phases and recuperation distribution. It sends a specification for the torque distribution to the motor control unit, which then activates the power electronics of the electric drive motors accordingly. The electromechanical brake servo works together with the ABS control unit and the ESC hydraulic unit if hydraulic brake pressure also needs to be generated. If brake regulation procedures are required during an active recuperation phase, the ABS control unit can, in the same way, initiate a reduction in recuperation or end it completely. At the same time, the system generates hydraulic brake pressure which can be used (if hydraulic brake pressure has not already been generated) to initiate regulation procedures for individual wheels.

As the proportion of hydraulic braking procedures performed by the service brakes is significantly lower in normal usage than on vehicles with conventional drive systems, the hydraulic brake system is activated in certain situations even though an electric braking procedure using recuperation would also have been possible. If the vehicle has been stationary for a longer period (> 6 hours), the first braking procedures are made hydraulically by the service brakes.

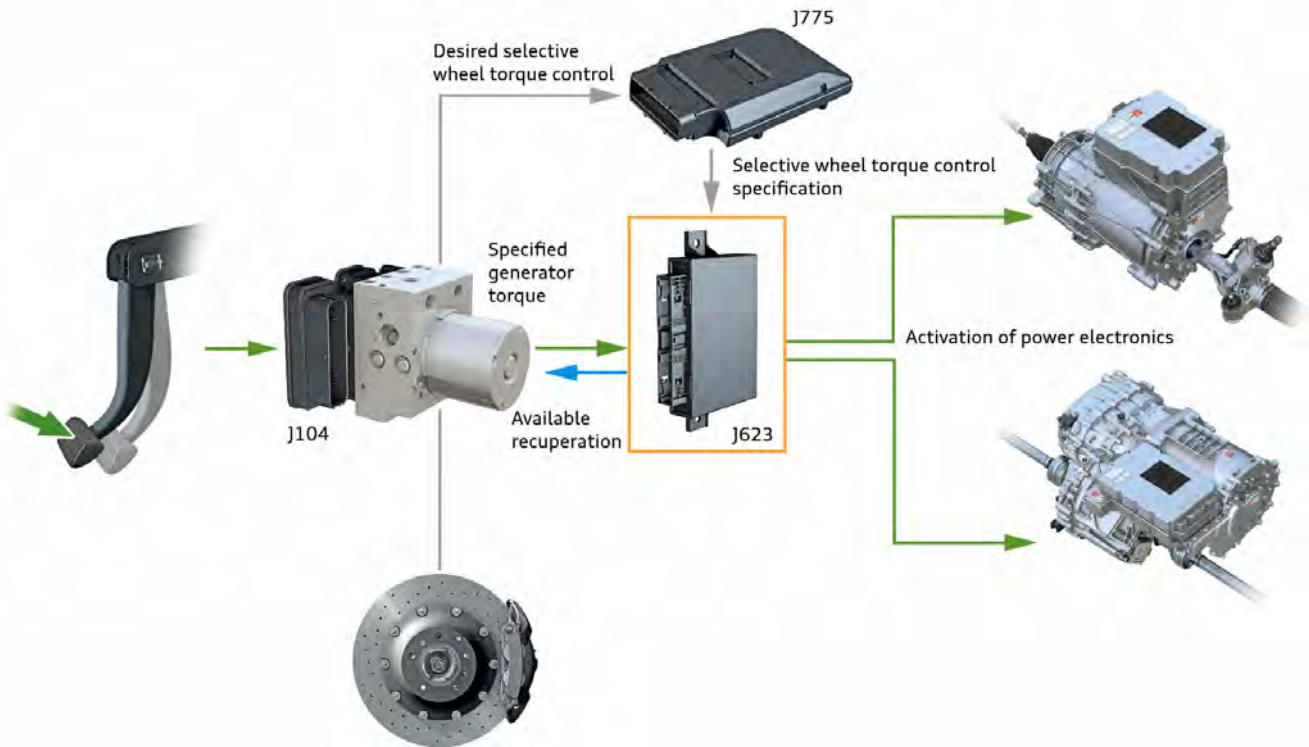

684_259

Service operations

The diagnostic address is "0003 - Brake Electronics - J104".

The entire module must be replaced if necessary. Replacing control unit J104 separately is not possible.

After the control unit has been coded online, the initial activation of the parking brake must be performed. This includes the following three basic settings:

- › Adjust parking brake:

Adjusting the parking brake is necessary after removing/installing or replacing the brake shoes. At the start, the mechanic is informed by the program that this basic setting is not necessary if this has not been done. After activating the basic setting, the parking brake is automatically opened fully. The mechanic is then asked to set the correct clearance between the brake pads and the brake drum according to the specifications in the Workshop Manual. This is performed at the adjustment mechanism. The parking brake is subsequently closed.
- › Break in parking brake:

This basic setting is not required on the optional ceramic brake system. Breaking in the parking brake must only be performed after the brake shoes have been removed/installed or replaced. At the start, the mechanic is informed by the program that this basic setting is not necessary if this has not been done. A distance defined by the control unit (approx. 180 m) must be driven at a low speed (approx. 15 - 20 km/h). Refer to information on vehicle diagnostic tester. During this, the brake shoes make contact with the drum to adjust the friction surfaces. The vehicle diagnostic tester shows the distance remaining until the full distance has been covered. We recommend that you do not perform this function on public roads.
- › Calibrate parking brake:

During calibration, the parking brake is opened fully and then closed as far as the clearance. The maximum opening position is then stored in the control unit. A table with the currently set actual clearance value and the tolerance range of the specified value is shown at the end of the calibration routine. If the actual value is not in the tolerance range specified, activation must be performed again.

After the ABS/ESC module has been installed successfully, it must be ensured that the brake lines have been connected at the correct positions on the ESC hydraulic unit. Final control diagnosis "0003 - Hydraulic valve interchange check" in the vehicle diagnostic tester can be used to do this. The procedure corresponds to that of other Audi models.

After the conventional bleeding procedure, the ESC hydraulic unit must be specially bled using the new function "0003 - Service bleeding". In this program, valves are activated in a defined manner to vent any air out of the hydraulic unit. A second mechanic, who should press the brake pedal as requested by the diagnostic tester, is required to do this.

The Guided Function "0003 - Remove brake pads" is used to remove/install or replace the electromechanical parking brake's brake pads and the rear brake discs. The parking brake is fully opened in this process. Removal and installation can then be performed according to the instructions in the Workshop Manual. After the mechanic has confirmed that the installation work has been performed, the program closes the brake. After removing/installing or replacing the electromechanical parking brake's brake pads, the system must be activated as described above.

The brake system is bled with regular brake bleeding equipment from the workshop equipment program. Four brake calipers with two bleeder connections each are used for the first time on an Audi model.

After the brake discs and/or brake pads of the service brakes are replaced, the function “Break in service brakes” must be activated on the vehicle diagnostic tester. After successful activation, the function will be performed in the background (without the vehicle diagnostic tester connected) during the next driving cycles. The function will be continued when a new driving cycle is started if defined conditions are met. During the routine, recuperation procedures are temporarily deactivated and the vehicle is decelerated using the service brakes. In the following driving cycles, a defined amount of braking energy is generated and used to bed in the brake pads and brake disc friction rings. Once the necessary braking power has been generated, the function is deactivated automatically and the vehicle once again prioritises deceleration via recuperation.

Final control diagnosis can be used to check the function of the hydraulic pump, the warning lamps, the brake lights and the sound boxes (acoustic signal).

Wheels and tires, tire pressure monitoring

The Audi e-tron GT comes with 19" forged aluminum wheels as standard equipment. 19" to 21" wheels are available as optional extras. The RS e-tron GT has 20" cast aluminum wheels as standard equipment. 20" or 21" wheels are available as optional extras. Both models have reduced rolling resistance summer tires as standard equipment (distance tires). These tires are also available for the optional 19" and 20" wheels. Summer tires designed for sporty handling (performance tires) are also available as optional equipment for the 21" wheels. All the wheels offered can be fitted with all-season tires if desired. Winter tires and snow chains can be used on all 19" and 20" wheels.

Depending on the market, the vehicle has the TMS breakdown set or a temporary spare wheel. A jack is included if the vehicle is equipped with a temporary spare wheel. The Tire Mobility System (TMS) and the temporary spare wheel may be offered as optional equipment on a market-specific basis.



Note

The offer structure in certain markets may differ from the one shown here.

Standard wheels

Optional wheels



Standard wheel for Audi e-tron GT

Forged aluminum wheel

Forged aluminum wheel

Forged aluminum wheel

8.0J x 19 (FA)

9.5J x 21 (FA)

8.0J x 19 (FA)

225/55 R19

265/35 R21

225/55 R19

10.0J x 19 (RA)

11.5J x 21 (RA)

10.0J x 19 (RA)

275/45 R19

305/30 R21

275/45 R19

For Audi e-tron GT only



Standard wheels	Optional wheels	
Standard wheel for RS e-tron GT	Cast aluminum wheel	Forged aluminum wheel
Optional for Audi e-tron GT Cast aluminum wheel	9.0J x 20 (FA)	9.5J x 21 (FA)
	245/45 R20	265/35 R21
9.0J x 20 (FA)	11J x 20 (RA)	11.5J x 21 (RA)
245/45 R20	285/40 R20	305/30 R21
11J x 20 (RA)		
285/40 R20		



Cast aluminum wheel	Forged aluminum wheel	Cast aluminum wheel
9.0J x 20 (FA)	9.5J x 21 (FA)	9.5J x 21 (FA)
245/45 R20	265/35 R21	265/35 R21
11J x 20 (RA)	11.5J x 21 (RA)	11.5J x 21 (RA)
285/40 R20	305/30 R21	305/30 R21

(FA) = front axle

(RA) = rear axle

Wheels 5, 6, 7, 8 and 9 in the table are fitted with aero blades which reduce the air resistance of the rotating wheels. The blades are made of high-quality plastic and are bolted to the wheel spokes. Repair kits to replace defective blades are available in service.

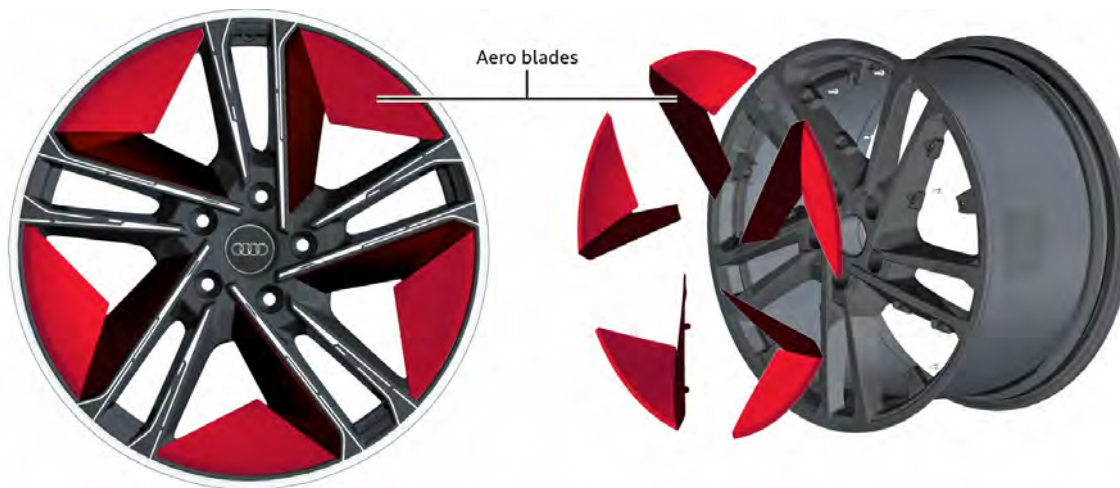

684_424

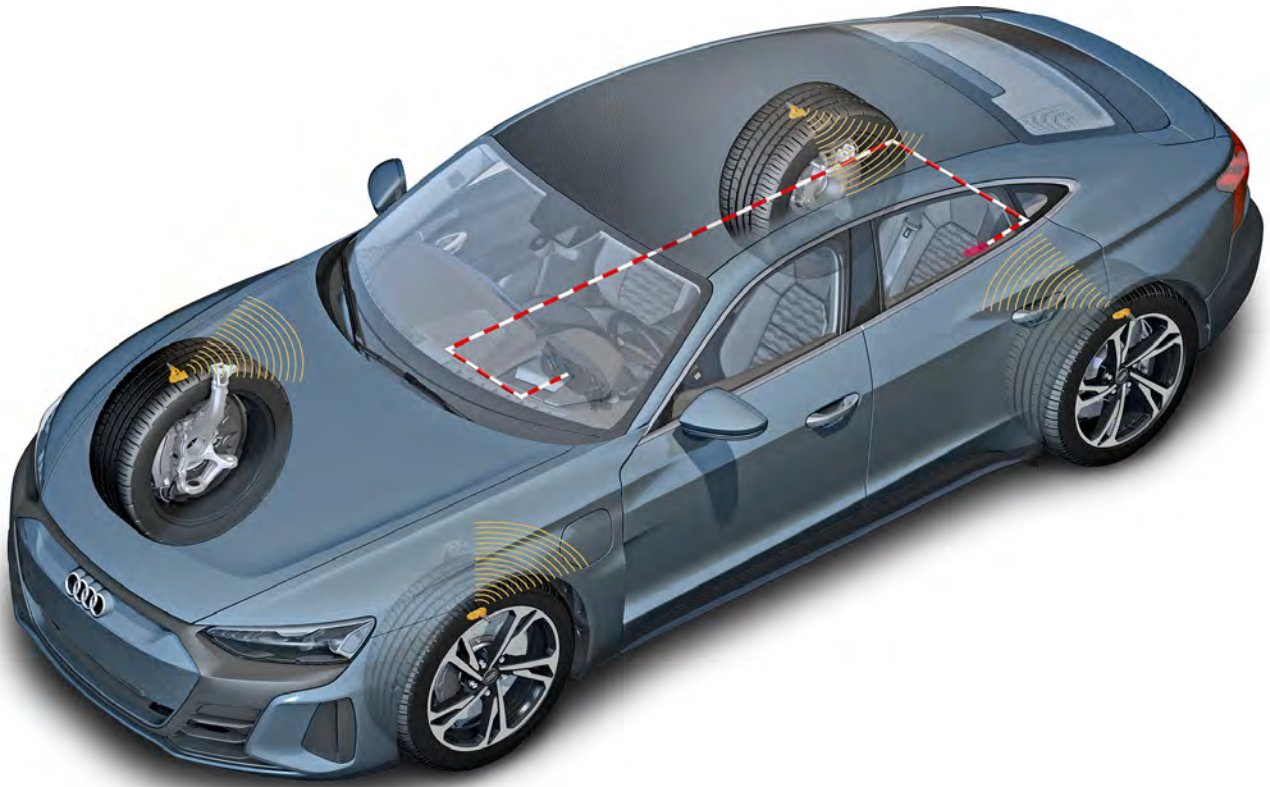

684_239

The third generation of the Tire Pressure Monitoring System is standard equipment. The system has the same construction and works in the same way as the system in the Audi Q7 (type 4M).

The antenna is integrated in the control unit, and the module is fitted on the rear axle subframe, as on the Q7 and Q8.

Electrics and electronics

12 Volt power supply

Lithium iron phosphate (LiFePO₄) battery (40 Ah)

General information and design

The Audi e-tron GT is the first Audi model that is not fitted with a lead-acid battery. Instead, it has a lithium-ion battery which functions as a starter battery and as a power source for the 12-Volt low-voltage system. This battery is a lithium iron phosphate (LiFePO₄) battery.

General information on lithium iron phosphate batteries

A **lithium iron phosphate battery** is a type of lithium-ion battery. The voltage of each cell is 3.3 V.

The positive electrode is made of lithium iron phosphate (LiFePO₄). The negative electrode is made of graphite with embedded lithium.

General advantages compared to a lead-acid battery:

- > **Lightweight construction**
Weight reduction of approx. 50 % compared to an AGM battery with the same capacity.
- > **Increased recuperation capacity**
- > **Less space required**
Volume of space required reduced by approx. 20% and battery monitor control unit J367 no longer required
- > **Service life**
Service life 2.5 times as long; cycle stability 7 times as high
- > **Power supply stability**
Significantly higher voltage stability
- > **Lead ban**
Reaction to lead ban that is expected between 2021 and 2025

Design of the 12 V LiFePO₄ battery in the Audi e-tron GT

The housing of the 12 V LiFePO₄ battery contains the electronics which include a battery sensor that measures the voltage, current and temperature. The battery monitor control unit J367 that is integrated in the battery earth wire on other Audi models is not fitted on the Audi e-tron GT. Diagnosis and adaption of the battery are performed via the data bus diagnostic interface J533 (gateway). The 12 V LiFePO₄ battery is a LIN slave of J533. A relay is also integrated in the battery housing. It remains closed under normal conditions but can sever the connection between the battery cells and the positive battery terminal if required.

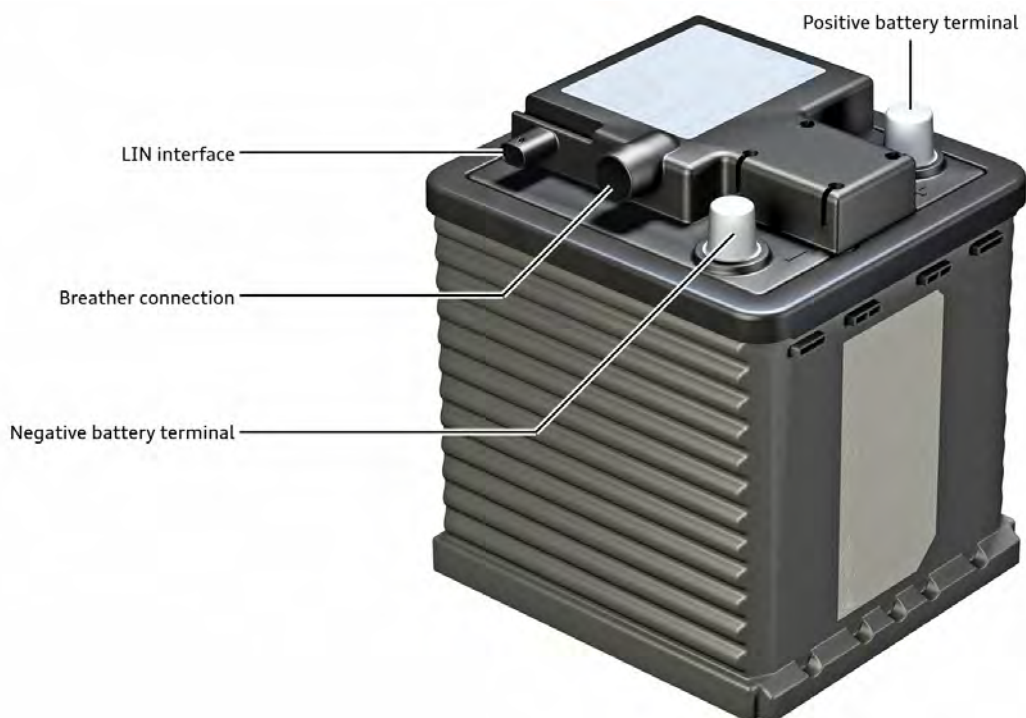

Cell configuration

The cells in the LiFePO₄ battery of the Audi e-tron GT are arranged in a 4S2P configuration. This means that 4 cell groups are connected in series, while each cell group consists of 2 cells that are connected in parallel.

This results in the following:

- > Voltage = $4 \times 3.3 \text{ V} = 13.2 \text{ V}$
- > Capacity = $2 \times 20 \text{ Ah} = 40 \text{ Ah}$



684_412

Battery operating range and special features of relay

The nominal voltage of this battery is 13.2 V. When the state of charge is 80 %, the voltage is 13.4 V, while at a state of charge of 100 % it is 13.8 V. The operating range of the battery is between 10 V and 14.8 V.

Lithium-ion batteries are sensitive to overcharging and to deep discharge. Both must be avoided to protect the lithium-ion cells.

After the relay has been opened, it closes again as soon as the state of charge returns to within the permitted limits.

The relay is opened to protect the lithium-ion cells when the following occurs:

- > Overcharging (The relay is closed again as soon as the voltage remains within the range of $11 \text{ V} < U < 14.8 \text{ V}$ for approx. 30 seconds. The relay makes an audible click when it closes. If the voltage was above 16 V, the relay can no longer be closed.)
- > Deep discharge (deep discharge protection) (The relay is closed again as soon as the voltage remains within the range of $11 \text{ V} < U < 14.8 \text{ V}$ for 10 to 30 seconds. There is an audible click. The battery should then be charged for at least 30 minutes.)
- > Short circuit (Depending on the severity, the relay has been opened or the fuse has blown -> Faulty battery!)
- > Overheating (The relay can no longer be closed -> Faulty battery!)

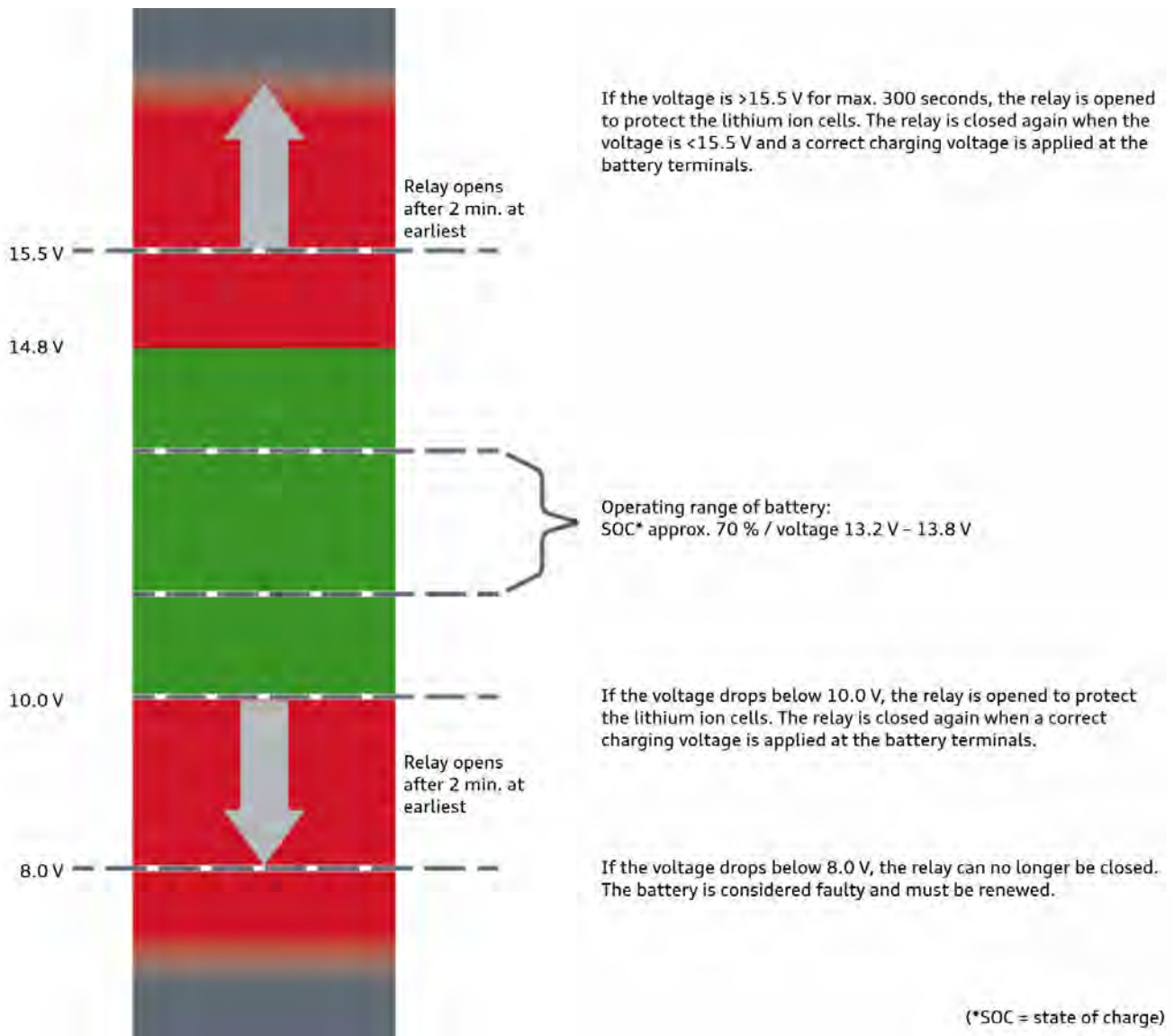

684_245

Fitting location

The 12 V LiFePO₄ battery is fitted in the front compartment. It is located on the right-hand side in left-hand-drive models and on the opposite side in right-hand-drive models. Wiring junction TV1 and the positive jump-start terminal are fitted on the 12 V battery. The terminal on wiring junction TV1 is for connecting an external battery charger.



Note

The vehicle cannot be operated if the 12 V LiFePO₄ battery is discharged. The Audi e-tron GT must NOT be used to jump-start other vehicles!

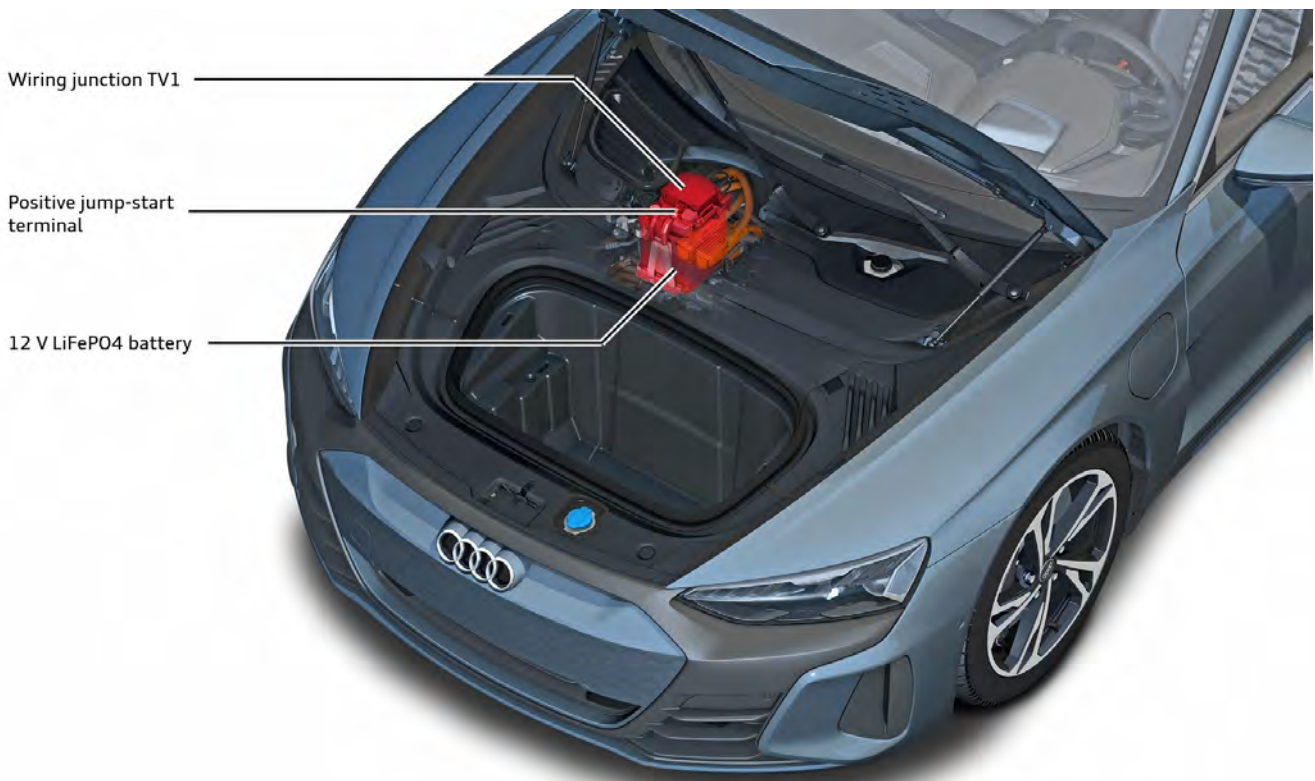

684_298

External charging

Like all other Audi models, the Audi e-tron GT depends on an intact power supply to the electrical system from the 12 V battery. As a result, if an Audi e-tron GT is in the showroom or in a workshop, an external battery charger needs to be connected. All battery chargers that are approved by Audi may be used to charge the battery in the Audi e-tron GT. Particularly when performing diagnostic work, it is important to use a charger that has a maximum charging current of at least 90 A.

If the charger is too small, the 12 V battery could become so discharged during diagnostic work – or, in the worst case scenario, during a software update – that the internal relay is opened.

Charging the battery while driving

While driving, the 12 V LiFePO₄ battery is supplied with power from the high-voltage battery via the voltage converter.

A separate 50 mm² aluminum wire (terminal 30 positive) leads to the positive battery terminal, then on to the battery and via a metal bridge to wiring junction TV1. TV1 is located directly on top of the 12 V battery. The positive jump-start terminal is also fitted here (12 V electrical system).

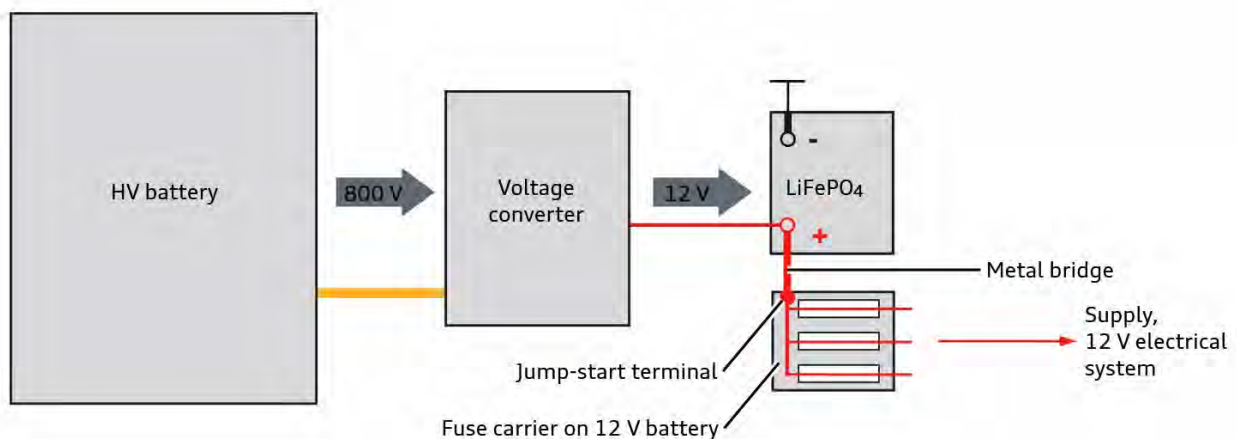

684_247

Re-charging concept

If the 12 V LiFePO₄ battery is discharged while the vehicle is stationary, a specific re-charging concept is implemented under certain conditions.

Example: The vehicle is stationary and has entered bus sleep mode. If the 12 V LiFePO₄ battery is discharged so much that its usable charge drops below 8 Ah and the state of charge of the high-voltage battery is higher than 10 %, the high-voltage network is activated and the 12 V battery is charged. This process continues until the 12 V battery has reached a capacity of 20 Ah or 30 minutes have passed. The high-voltage network is then deactivated again and the vehicle enters bus sleep mode. This process can be repeated 8 times per terminal 15 cycle.



Important

- ▶ The high-voltage system of an Audi e-tron GT may be active even though the vehicle is parked and locked.

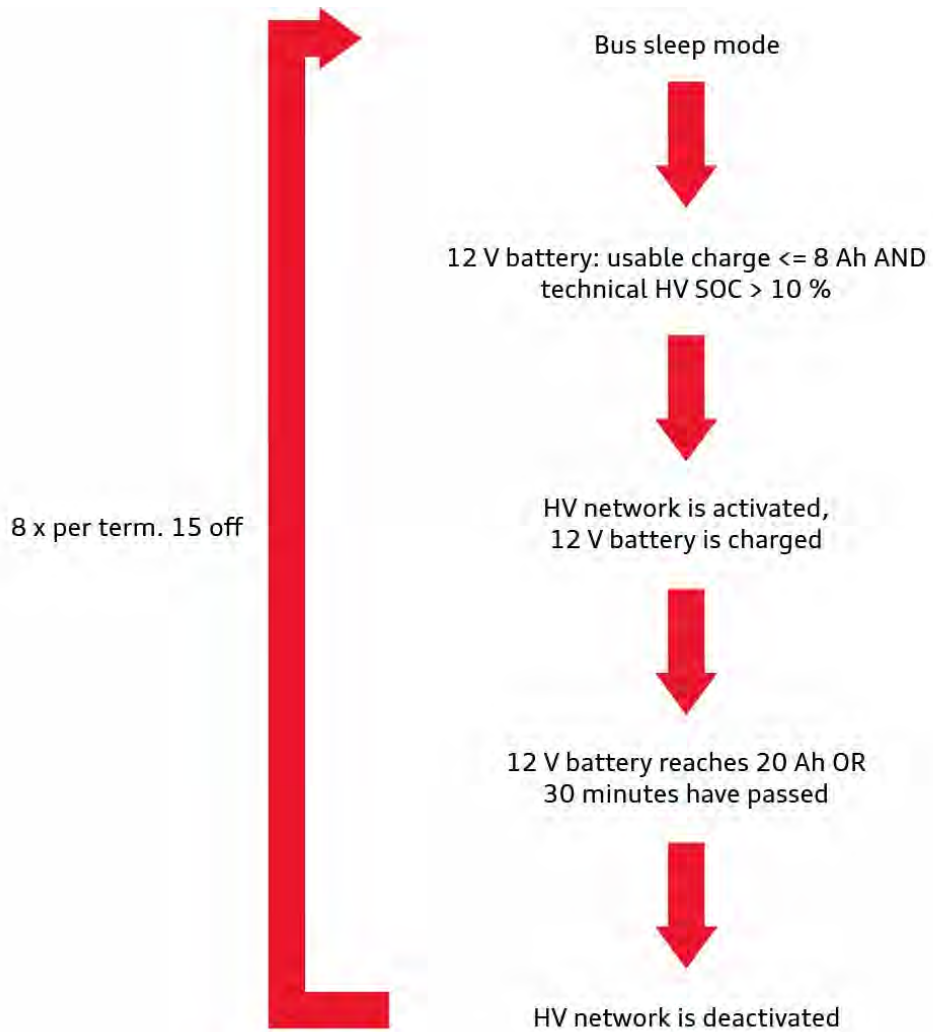

684_250

HV High-voltage
SOC State of charge

Relay and fuse carriers

Location of relay and fuse carriers

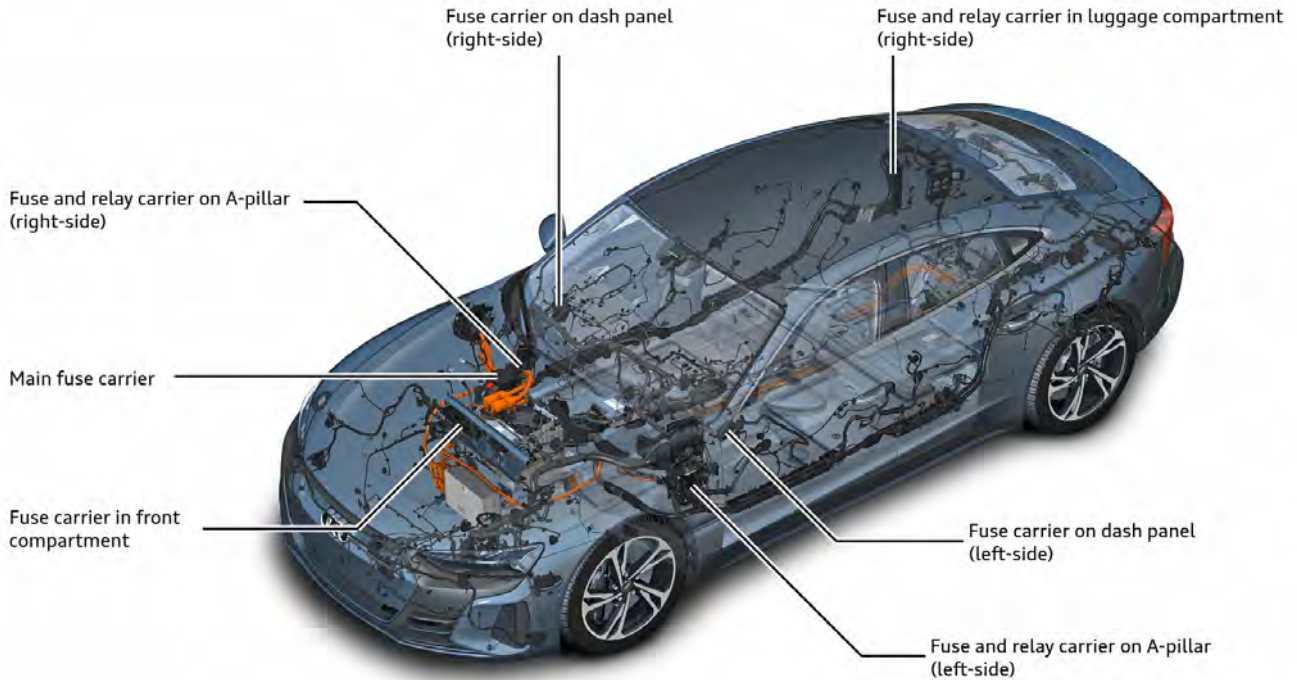

684_261

As shown in the illustration, the relay and fuse carriers are fitted in various locations on the Audi e-tron GT.

The main fuse carrier is fitted on the LiFePO₄ battery. The fuses inside it protect the electrical circuits for the components that use the most power, as well as the power supply lines of the other relay and fuse carriers in the vehicle. Additional relay and fuse carriers are located in the front compartment, on the A-pillars (both sides), on the dash panel (both sides) and in the luggage compartment (right-side).

Fuse and relay carrier on A-pillar (driver's side)

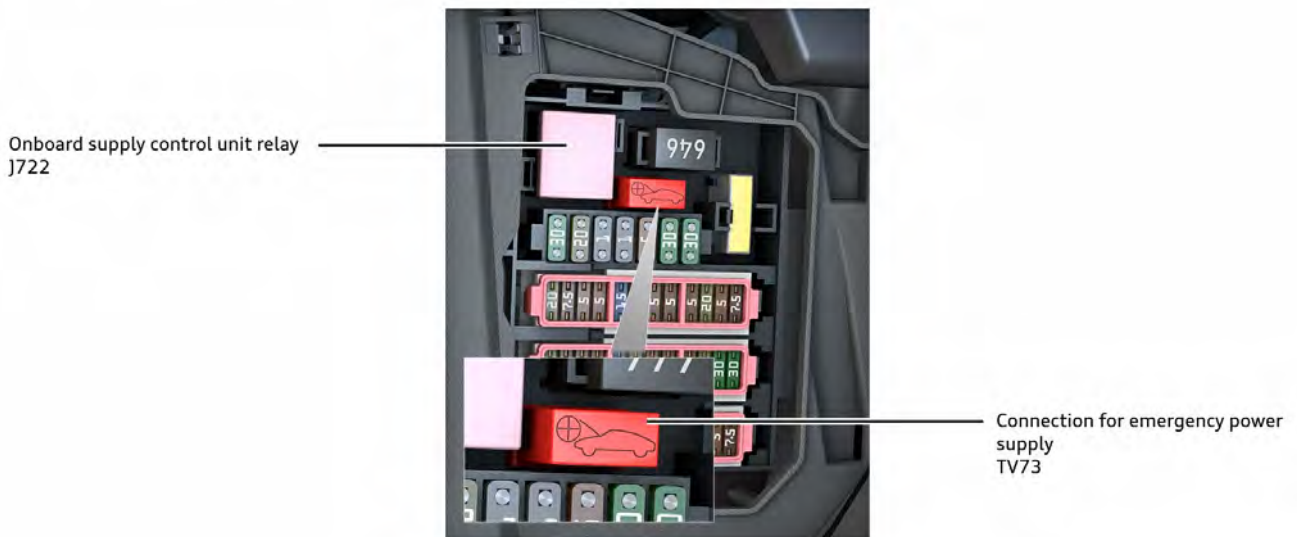

684_431

The relay and fuse carrier with the connection for an emergency power supply is a special component. It is fitted on the A-pillar on the driver's side; in this illustration showing a left-hand drive vehicle, that means on the left A-pillar.

Connection for emergency power supply TV73 is protected by a red cover. On the cover is a plus symbol and the outline of a vehicle with the hood open. Onboard supply control unit relay J722 is fitted to the left of it.

Emergency power supply

Why an emergency power supply is necessary

The 12 V battery is fitted in the vehicle's front compartment. The hood of the Audi e-tron GT is unlocked via a button on the end face of the driver's door. If the electrical system has no power (e.g. if the 12 V battery is discharged or faulty), it is not possible to unlock the hood. For this reason, a special procedure is required to establish an emergency power supply in order to open the hood and access the 12 V battery.

Using the connection for emergency power supply

If the electrical system of the Audi e-tron GT has no power, the driver's door must first be unlocked manually using the emergency key. After opening the driver's door, the relay and fuse carrier on the A-pillar must be exposed. The connection for emergency power supply can then be pulled slightly out of the fuse carrier and connected to the positive terminal of the external power source. The negative terminal of the external power source must be connected to the striker of the driver's door lock on the B-pillar. On vehicles with an anti-theft alarm system, the horn of the alarm system will sound after this is done. It can be switched off by pressing the main unlock button on the remote control key. The unlock button for the hood must then be pressed for at least 2 seconds in order to open the hood.

This procedure is also described in the Owner's Manual.

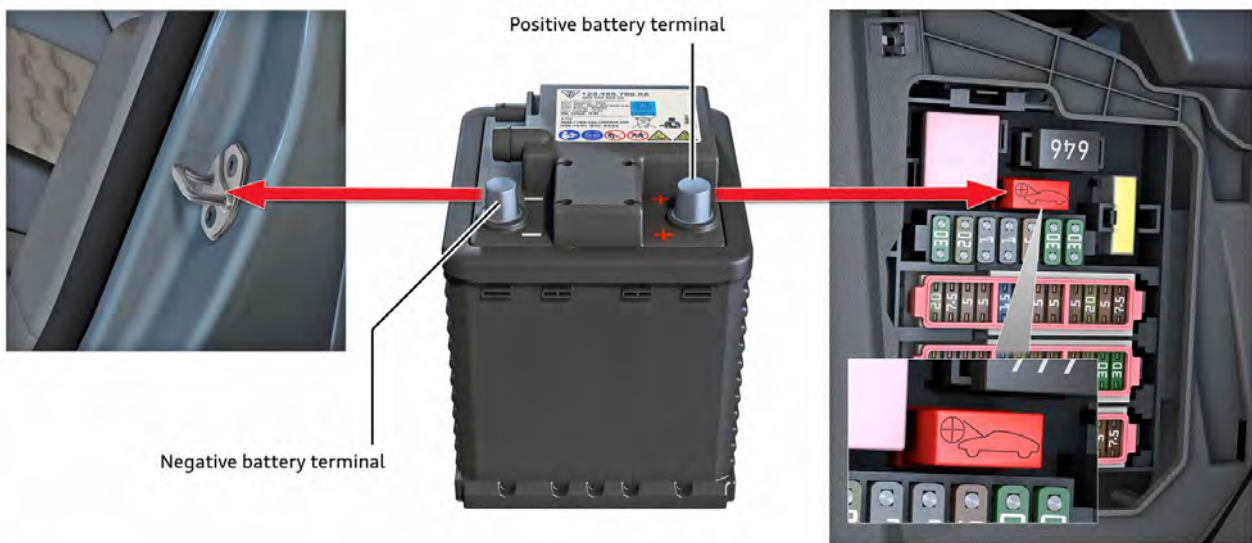

684_415

Onboard supply control unit relay J722

When the power supply for the electrical system is intact, convenience system central control unit J393 is supplied with power via main fuse carrier TV1. The power flows via contacts 4 and 3 of onboard supply control unit relay J722, which are bridged in the rest state.

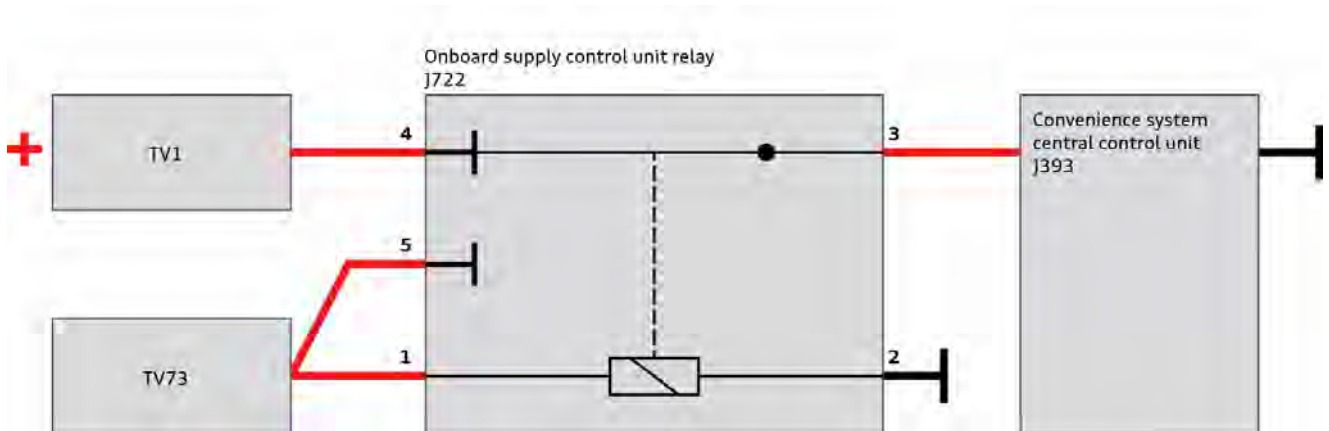

684_266

When the electrical system is without power, an external power source can be connected to connection for emergency power supply TV73. Doing so switches the relay. Convenience system central control unit J393 is now supplied with power by the external power source.

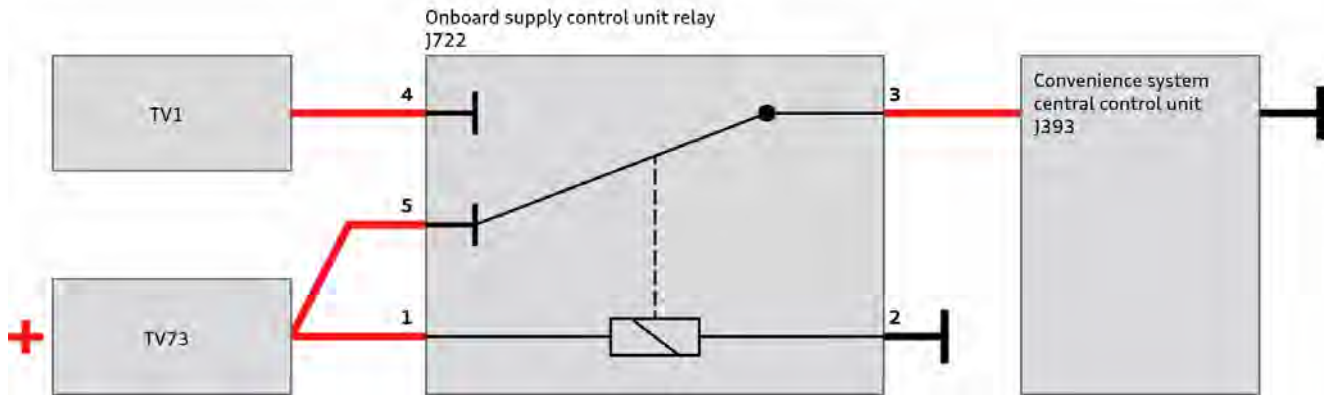

684_267

Networking

Data transmission, fitting locations and topology of control units

Bus systems used on the Audi e-tron GT

Bus systems	Wire colour	Method	Data transfer rate
Convenience CAN		Electrical bus system	500 kbit/s
Convenience CAN 2		Electrical bus system	500 kbit/s
Extended CAN		Electrical bus system	500 kbit/s
Hybrid CAN		Electrical bus system	500 kbit/s
Dash panel insert CAN		Electrical bus system	500 kbit/s
Infotainment CAN		Electrical bus system	500 kbit/s
Connect CAN		Electrical bus system	500 kbit/s
Diagnostics CAN		Electrical bus system	500 kbit/s
Information electronics 1 CAN		Electrical bus system	500 kbit/s
FlexRay		Electrical bus system	10 Mbit/s
MOST bus		Fibre optic bus system	150 Mbit/s
LIN bus		Electrical single wire bus system	20 kbit/s
Sub-bus systems		Electrical bus system	500 kbit/s
			1 Mbit/s
Ethernet		Electrical bus system	100 Mbit/s

Fitting locations and topology of control units

Notes on illustrations

The following illustrations are sorted according to the different bus systems on the Audi e-tron GT (type F8) and provide information on:

- › The location of the control unit in the vehicle
- › The bus system via which the control unit participates in communication
- › The control unit code
- › The diagnostic address
- › The power supply
- › The bus termination resistor

The following illustrations show all control units which may be connected to the various bus systems.

Some control units are the result of optional or country-specific equipment.

The illustrations are intended as an overview of the fitting locations and the various data transmission paths between the control units. They do not show the exact fitting locations and do not provide any information about the routing of wiring or the nodes in the wiring harness. They are therefore not a substitute for the relevant current flow diagrams or Workshop Manuals. For illustration purposes, the LIN slaves are allocated to the control unit and do not reflect the fitting location of the components. For the LIN slaves shown, several components are sometimes grouped together to ensure a reasonable degree of clarity in the illustrations. For example, in the area of the air conditioner control motors or the interior lighting modules, only one LIN participant is shown when in reality there is a chain of LIN slaves.

A left-hand drive vehicle is shown in the illustration.

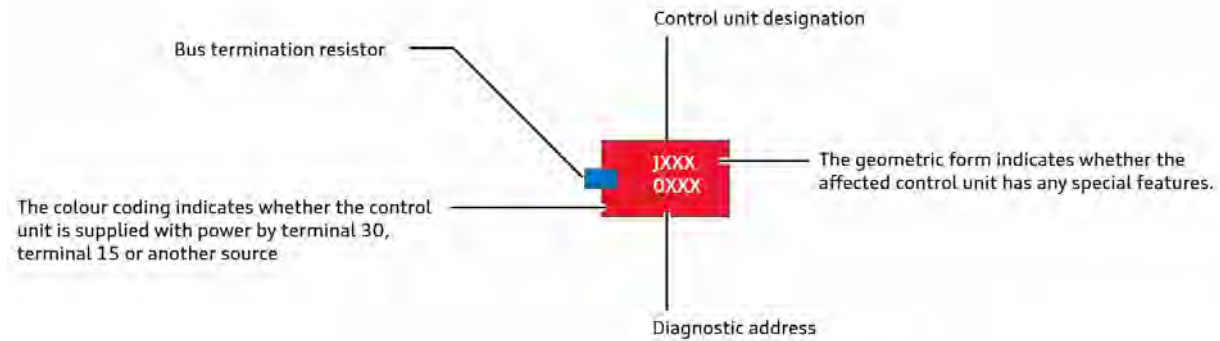

684_122_4

Convenience CAN

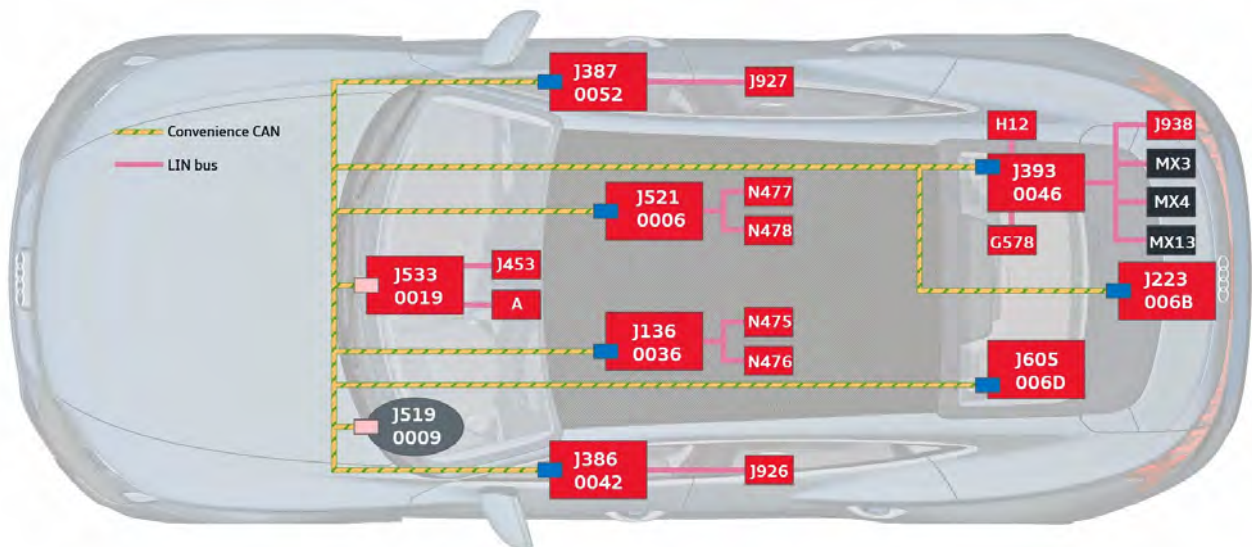

684_122

Key:

- J136** Control unit for seat and steering column adjustment with memory function (under driver's seat)
- N475** Valve block 1 in driver seat
- N476** Valve block 2 in driver seat
- J223** Rear spoiler adjustment control unit (in rear lid)
- J386** Driver door control unit (in driver's door)
- J926** Rear driver side door control unit
- J387** Front passenger door control unit (in front passenger's door)
- J927** Rear passenger side door control unit
- J393** Convenience system central control unit (on right in luggage compartment)
- G578** Anti-theft alarm sensor
- H12** Alarm horn
- J938** Rear lid power opening control unit
- MX3** Left tail light cluster

- MX4** Right tail light cluster
 - MX13** Centre tail light cluster
 - J521** Control unit for front passenger seat adjustment with memory function (under front passenger's seat)
 - N477** Valve block 1 in front passenger seat
 - N478** Valve block 2 in front passenger seat
 - J533** Data bus diagnostic interface (on centre tunnel)
 - A** Battery
 - J453** Multifunction steering wheel control unit
 - J605** Rear lid control unit (in side panel on rear left)
 - J519** Onboard supply control unit
- The onboard supply control unit communicates via convenience CAN bus 2 (refer to illustration of convenience CAN bus 2) but contains a low-ohm termination resistor for the convenience CAN bus and is therefore also shown in this illustration.

- Terminal 30 power supply
- Terminal 15 power supply
- 120 ohms
- 9200 ohms

Convenience CAN 2

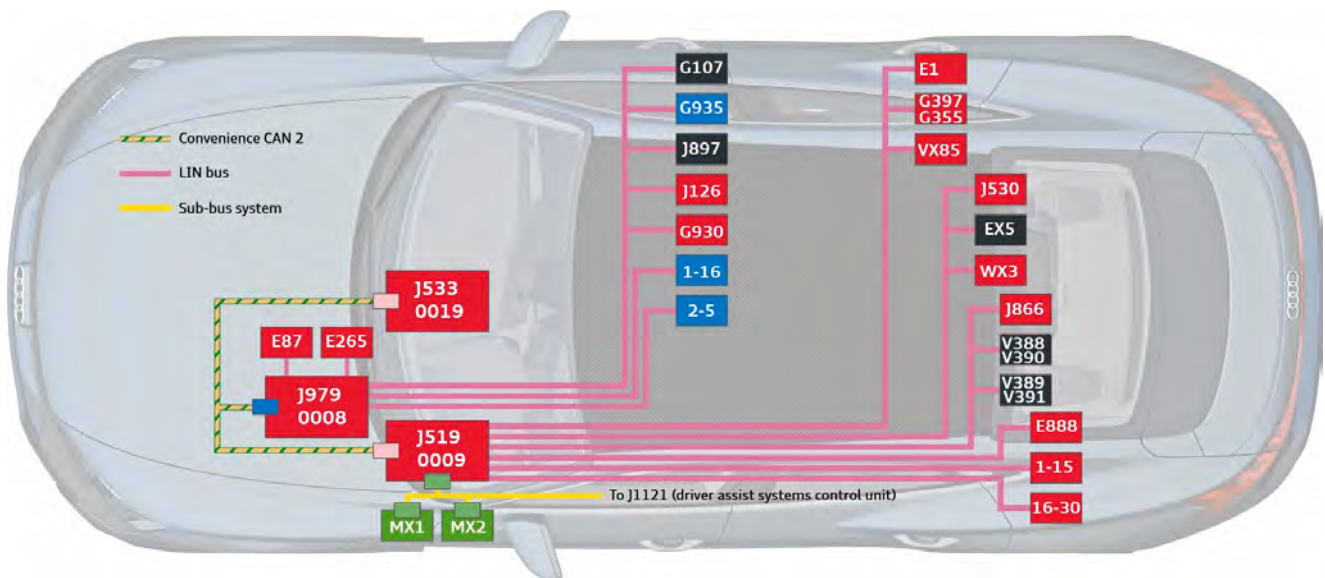







684_126

Key:

- J519** Onboard supply control unit (on A-pillar, left-side; fitted in area of A-pillar, right-side, on right-hand drive vehicles)
- E1** Light switch
- EX5** Interior mirror
- G355** Humidity sender
- G397** Rain and light sensor
- J530** Garage door operation control unit
- J866** Control unit for electrically adjustable steering column
- MX1** Front left headlight
- MX2** Front right headlight
- V512** Front left seat backrest fan 1
- V514** Front left seat cushion fan 1
- V516** Front right seat backrest fan 1
- V518** Front right seat cushion fan 1

VX58	Windscreen wiper
WX3	Front roof module
1-15	Interior lighting modules
16-30	Interior lighting modules
J533	Data bus diagnostic interface (on centre tunnel)
J979	Heater and air conditioning system control unit (fitted on left side of air conditioning unit)
E87	Operating and display unit for front air conditioning system
E265	Operating and display unit for rear air conditioning system
G107	Sunlight penetration photosensor
G897	Interior air quality sensor
G930	Air conditioner sensor for fine particle concentration
G935	External air quality and air humidity sensor
J126	Fresh air blower control unit
1-16	Flap control motors on air conditioning unit (front)
2-5	Flap control motors on air conditioning unit (rear)

	Terminal 30 power supply
	Terminal 15 power supply
	Power supply via J519
	Power supply via J979
	120 ohms
	1800 ohms
	9200 ohms

Extended CAN

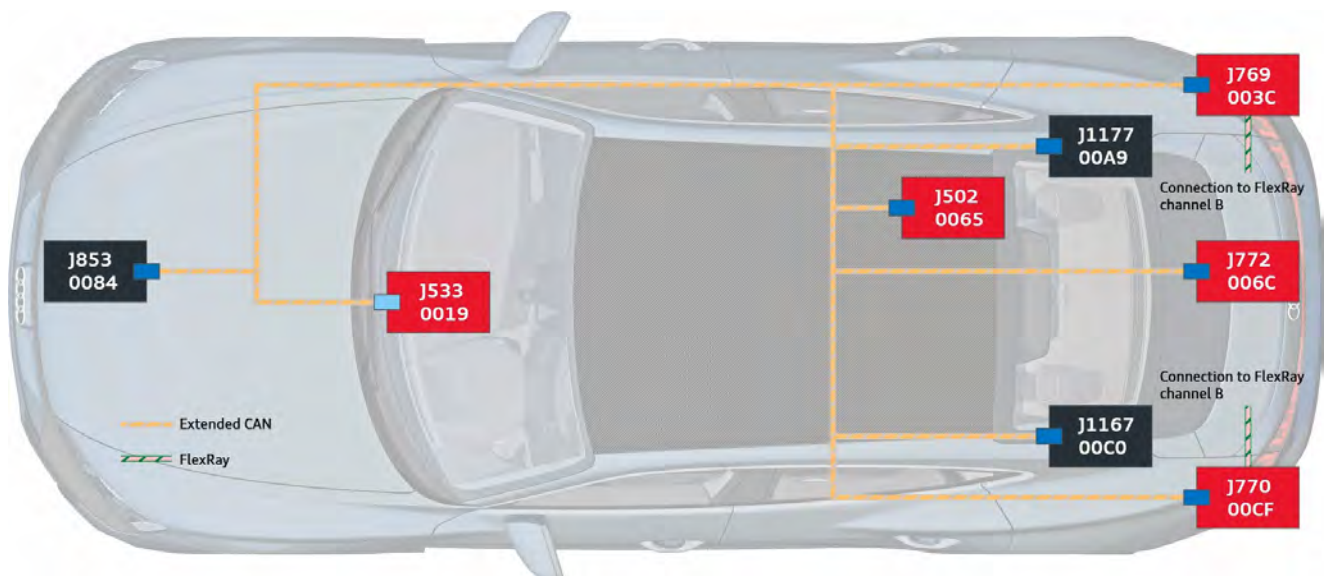

684_127

Key:

J502	Tire Pressure Monitoring System control unit (on rear subframe)
J533	Data bus diagnostic interface (on centre tunnel)
J769	Lane change assist control unit (under rear bumper cover, right-side)
J770	Lane change assist control unit 2 (under rear bumper cover, left-side)
J772	Reversing camera system control unit (in rear lid)
J853	Control unit for night vision system (in front luggage compartment, on front cross member, right-side)

- J1167 Engine sound generator control unit 2 (in rear luggage compartment, left-side)
- J1177 Engine sound generator control unit 3 (in rear luggage compartment, right-side)

- Terminal 30 power supply
- Terminal 15 power supply
- 66 ohms
- 9200 ohms



Note

The next two illustrations are not realistic depictions of how the FlexRay control units are networked. Precisely how the individual branches of the FlexRay control units are connected together is shown subsequently in a separate illustration.

Control units which are connected both to FlexRay channel A and FlexRay channel B appear in both illustrations.

FlexRay channel A

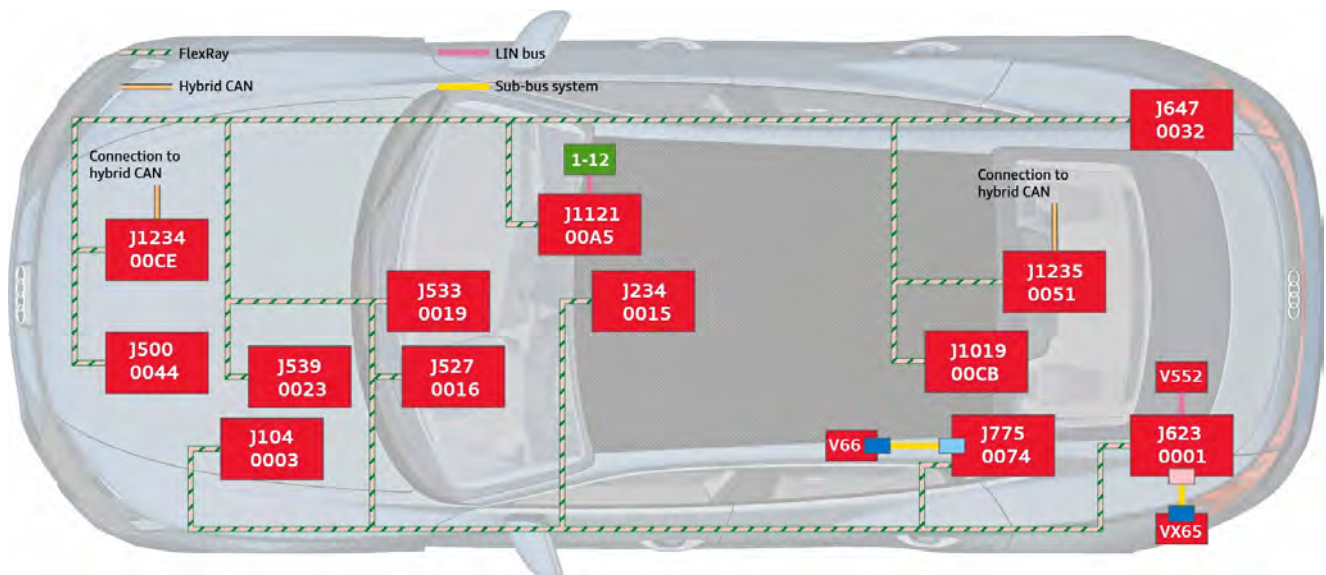

684_128

Key:

- J104 ABS control unit (in front luggage compartment, centre left)
- J234 Airbag control unit (on centre tunnel)
- J500 Power steering control unit (in underbody on steering rack)
- J527 Steering column electronics control unit (on steering column)
- J533 Data bus diagnostic interface (on centre tunnel)
- J539 Brake servo control unit (in front compartment, left-side)
- J623 Motor control unit (in luggage compartment, rear left)
- VX65 Gear actuator
- V552 Gearbox auxiliary hydraulic pump
- J647 Axle differential lock control unit (in rear luggage compartment, right-side)
- J775 Running gear control unit (in rear luggage compartment, left-side)
- V66 Adaptive suspension compressor motor
- J1019 Rear wheel steering control unit (on underbody, left-side)
- J1121 Driver assist systems control unit (on centre tunnel in front passenger's footwell, i.e. right footwell on left-hand drive vehicles and left footwell on right-hand drive vehicles)
- 1-12 Ultrasonic sensors

- J1234** Electric drive control unit for front axle (on electric motor on front axle)
- J1235** Electric drive control unit for rear axle (on electric motor on rear axle)

- Terminal 30 power supply
- Terminal 15 power supply
- Power supply via J1121
- 66 ohms
- 120 ohms
- 9200 ohms

FlexRay - channel B

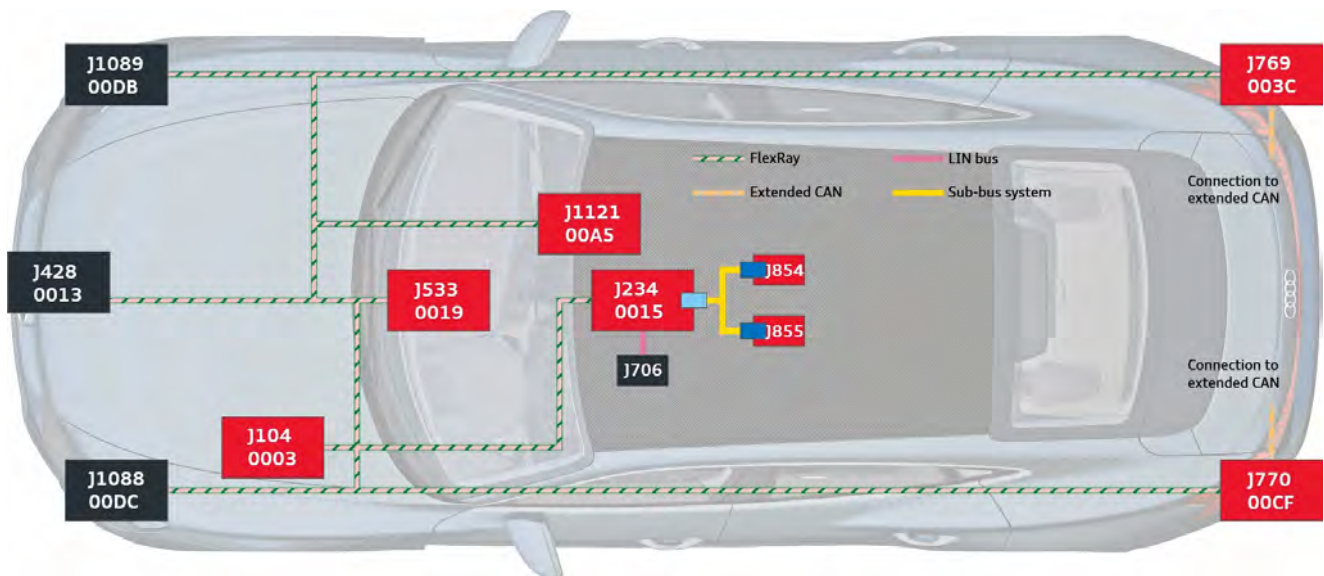

684_129

Key:

- J104** ABS control unit (in front luggage compartment, centre left)
- J234** Airbag control unit (on centre tunnel)
- J706** Seat occupied recognition control unit
- J854** Control unit for front left belt tensioner
- J855** Control unit for front right belt tensioner
- J428** Adaptive cruise control unit (on front bumper cross member)
- J533** Data bus diagnostic interface (on centre tunnel)
- J769** Lane change assist control unit (under rear bumper cover, right-side)
- J770** Lane change assist control unit 2 (under rear bumper cover, left-side)
- J1088** Front left radar sensor control unit for object detection (under front bumper cover, left-side)
- J1089** Front right radar sensor control unit for object detection (under front bumper cover, right-side)
- J1121** Driver assist systems control unit (on centre tunnel in front passenger's footwell, i.e. right footwell on left-hand drive vehicles and left footwell on right-hand drive vehicles)

- Terminal 30 power supply
- Terminal 15 power supply
- 66 ohms
- 9200 ohms

Topology of FlexRay control units

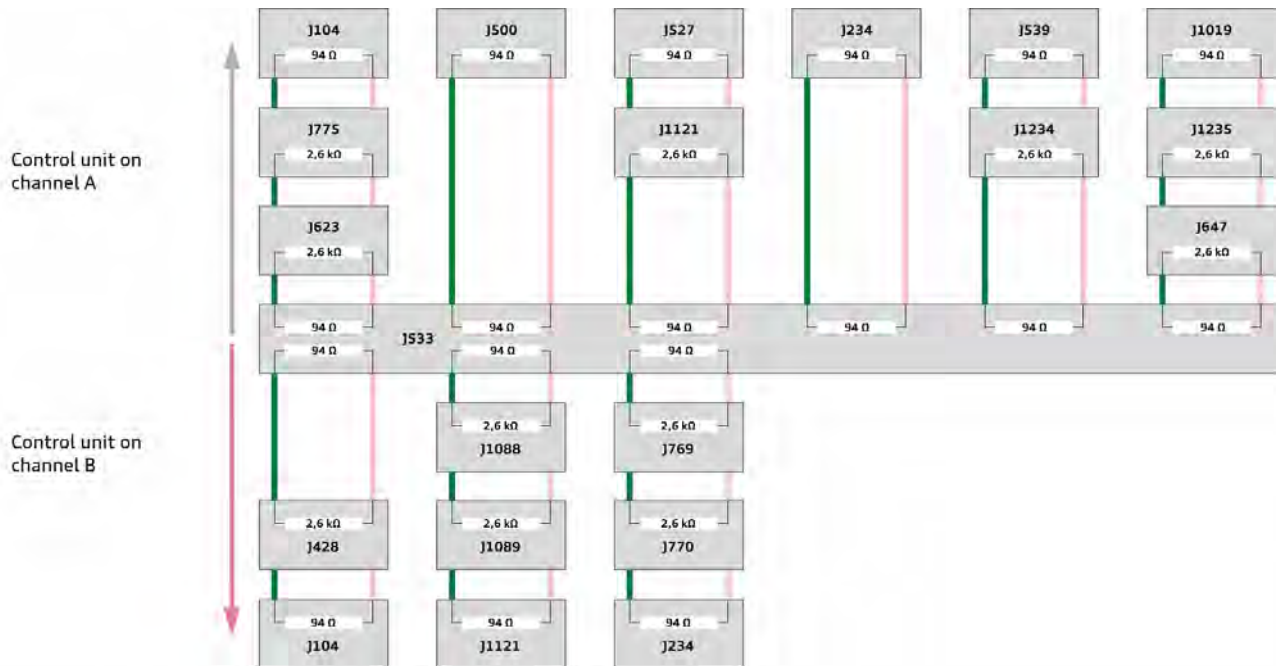

684_130

Key:

J104	ABS control unit
J234	Airbag control unit
J428	Adaptive cruise control unit
J500	Power steering control unit
J527	Steering column electronics control unit
J533	Data bus diagnostic interface
J539	Brake servo control unit
J623	Motor control unit
J647	Axle differential lock control unit
J769	Lane change assist control unit
J770	Lane change assist control unit 2
J775	Running gear control unit
J1019	Rear wheel steering control unit
J1088	Front left radar sensor control unit for object detection
J1089	Front right radar sensor control unit for object detection
J1121	Driver assist systems control unit
J1234	Electric drive control unit for front axle
J1235	Electric drive control unit for rear axle

Hybrid CAN

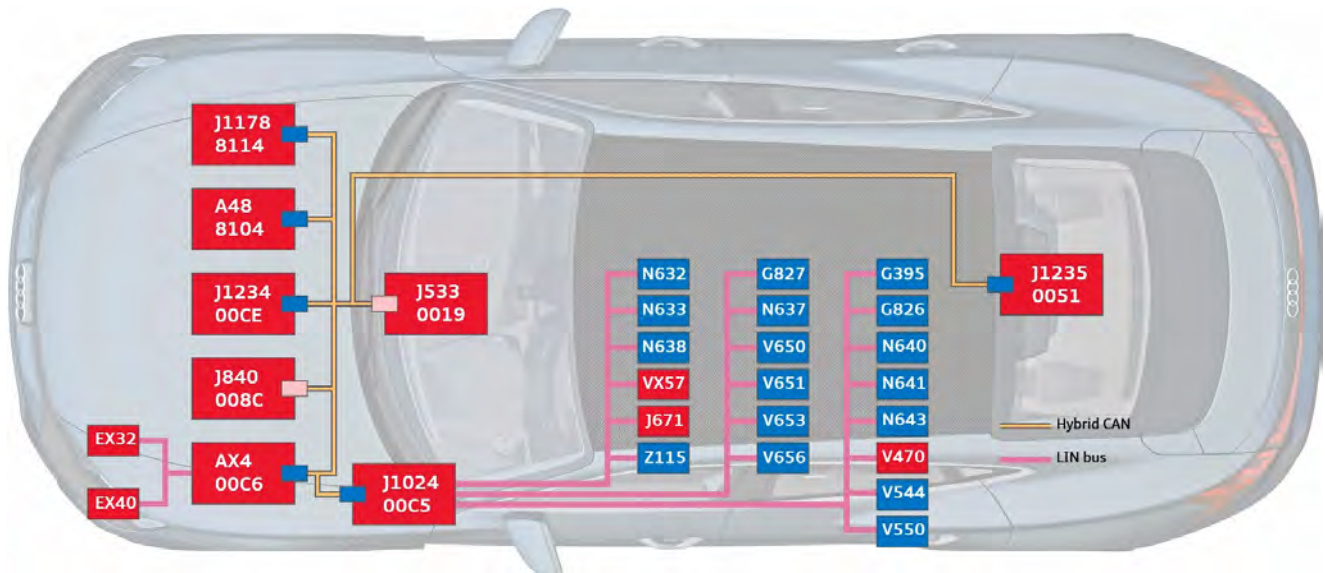

684_131

Key:

A48	Voltage converter for 800 V, 400 V, 48 V, 12 V (on electric motor on front axle)
AX4	Charging unit 1 for high-voltage battery (on electric motor on front axle)
EX32	Module for battery charge selector buttons
EX40	Module 2 for battery charge selector buttons
J533	Data bus diagnostic interface (on centre tunnel)
J840	Battery regulation control unit (on electric motor on front axle)
J1024	Thermal management control unit (on A-pillar, left-side; fitted in area of A-pillar, right-side, on right-hand drive vehicles)
G395	Refrigerant pressure and temperature sender
G826	Refrigerant pressure and temperature sender 2
G827	Refrigerant pressure and temperature sender 3
J671	Radiator fan control unit 2
N632	Coolant changeover valve 1
N633	Coolant changeover valve 2
N637	Refrigerant expansion valve 2
N638	Refrigerant expansion valve 3
N640	Refrigerant shut-off valve 2
N641	Refrigerant shut-off valve 3
N643	Refrigerant shut-off valve 5
V470	Electrical air conditioner compressor
V544	Radiator blind control motor
V550	Radiator blind control motor 2
V650	Changeover and mixing valve for thermal management
V651	Changeover and mixing valve 2 for thermal management
V653	Changeover and mixing valve 4 for thermal management
V656	Changeover and mixing valve 7 for thermal management
VX57	Radiator fan
Z189	High-voltage heater (PTC)
J1178	Power contactor with boost function (on electric motor on front axle)
J1234	Electric drive control unit for front axle (on electric motor on front axle)
J1235	Electric drive control unit for rear axle (on electric motor on rear axle)

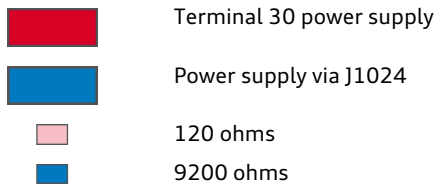

Dash panel insert CAN

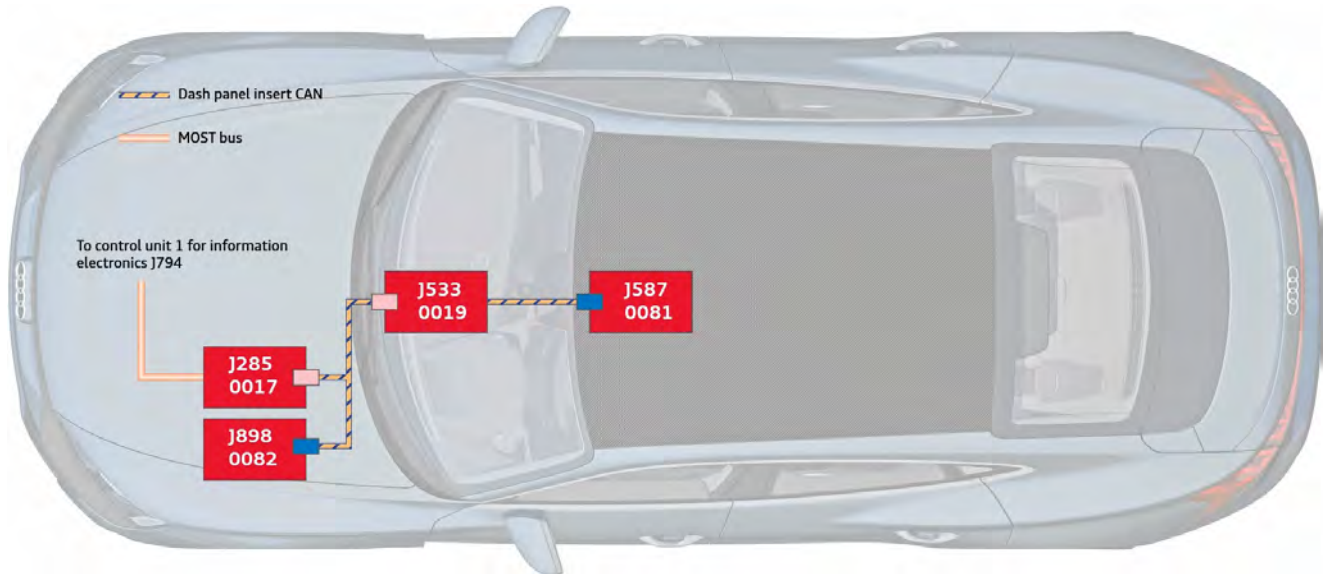

684_132

Key:

- J285** Control unit in dash panel insert (in dash panel on driver's side)
- J533** Data bus diagnostic interface (on centre tunnel)
- J587** Selector lever sensors control unit (in centre console)
- J898** Control unit for head-up display (in dash panel on driver's side)

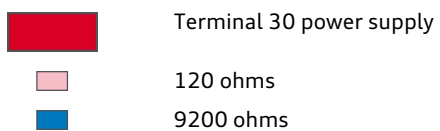

Infotainment CAN/connect CAN/Information electronics 1 CAN

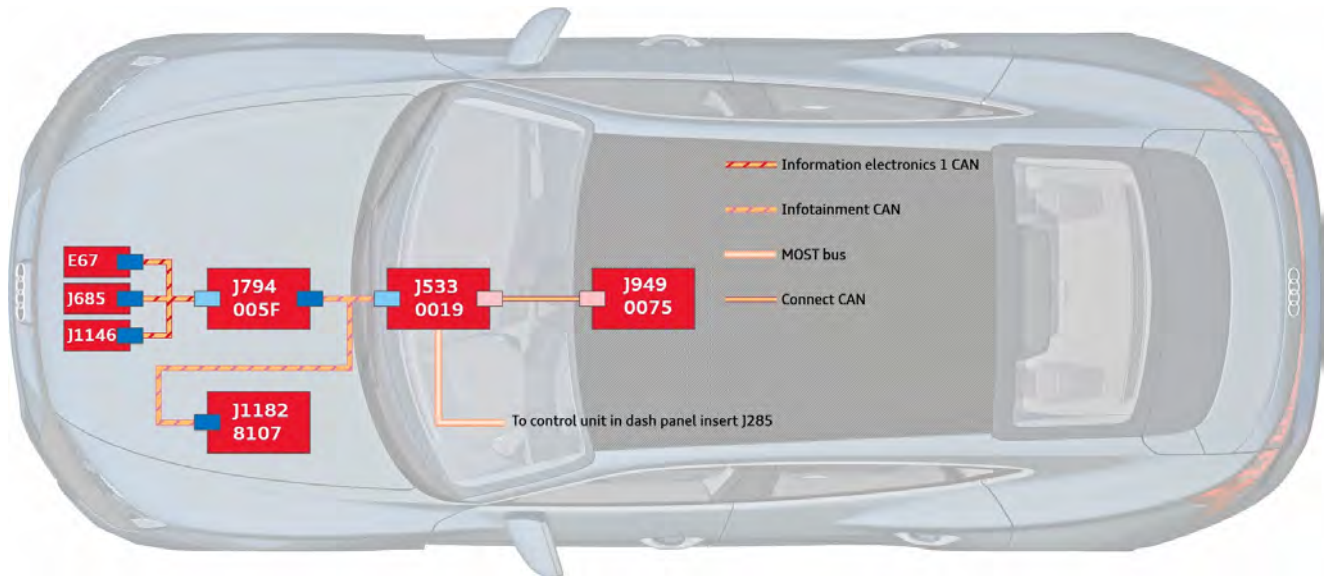

684_133

Key:

- J533** Data bus diagnostic interface (on centre tunnel)
- J794** Control unit 1 for information electronics (in dash panel near centre console)
- E67** Driver side volume regulator
- J685** MMI display
- J1146** Charging unit 1 for mobile devices
- J949** Emergency call module control unit and communication unit (on centre tunnel)
- J1182** Control unit for radio-controlled parking

- Terminal 30 power supply
- 66 ohms
- 120 ohms
- 9200 ohms

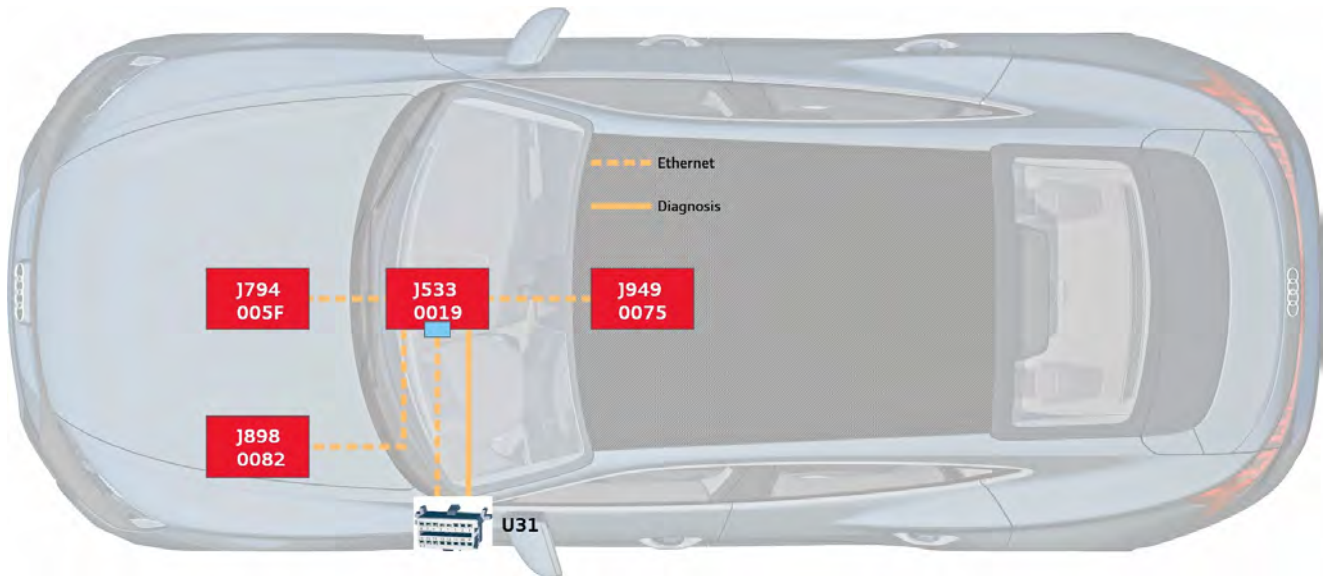

Diagnostics CAN/Ethernet



684_134

Key:

- J533** Data bus diagnostic interface (on centre tunnel)
- J794** Control unit 1 for information electronics (in dash panel near centre console)
- J898** Control unit for head-up display (in dash panel on driver's side)
- J949** Emergency call module control unit and communication unit (on roof module)
- U31** Diagnostic connection

-  Terminal 30 power supply
-  66 ohms

Control units

Data bus diagnostic interface J533 (gateway)

Data bus diagnostic interface J533 (gateway) is one of the main control units on the Audi e-tron GT, as it is on other models. As it is a network system gateway, it is connected to all bus systems except for the information electronics CAN and the MOST bus. It is fitted on the centre tunnel.

- › Diagnostic address
 - › 0019
- › Tasks of data bus diagnostic interface J533
 - › Network system gateway
 - › Controller for FlexRay bus
 - › Energy manager for low-voltage system and high-voltage system
 - › High-voltage coordinator
 - › Diagnostic master
 - › Interface for various connect services
 - › Manages diagnostics firewall
- › LIN master for
 - › A - Battery (12 V)
 - › J453 - Multifunction steering wheel control unit



Data bus diagnostic interface J533

684_297

Onboard supply control unit J519

Onboard supply control unit J519 is another important control unit on the Audi e-tron GT. It is fitted on the A-pillar on the driver's side.

- › Diagnostic address
 - › 0009
- › Tasks of onboard supply control unit J519
 - › Exterior lighting master
 - › Interior lighting master
 - › Diagnostic gateway for the lighting control units
- › Data bus connections
 - › Convenience CAN 2
 - › Sub-bus connection to lighting control units and to driver assist systems control unit J1121
 - › Connection to convenience CAN (contains a 120-ohm termination resistor)
- › LIN master for
 - › A27 - Output module 1 for right LED headlight
 - › A31 - Output module 1 for left LED headlight
 - › E1 - Light switch
 - › EX35 - Centre switch module 2 in dash panel
 - › G355 - Humidity sender
 - › G397 - Rain and light sensor
 - › J400 - Wiper motor control unit
 - › J528 - Roof electronics control unit
 - › J530 - Garage door operation control unit
 - › J866 - Control unit for electrically adjustable steering column
 - › V388 - Driver seat backrest fan
 - › V389 - Front passenger seat backrest fan
 - › V390 - Driver seat cushion fan
 - › V391 - Front passenger seat cushion fan
 - › Y7 - Automatic anti-dazzle interior mirror
 - › Interior lighting modules



Onboard supply control unit J519

684_263

Terminal control

The terminal control on the Audi e-tron GT corresponds to that on the Porsche Taycan. As a result, there are differences to Audi vehicles which are fully based on the MLBevo2 electrics platform.

The terminals in question are S, 15 and 50. The Audi e-tron GT is the first Audi vehicle with automatic control of terminal 15. In certain circumstances, terminal 15 may be switched on without the driver actively pressing entry and start authorization button E408.

Meaning of individual terminals:

- > Terminal S = key contact; originally switched by inserting ignition key
- > Terminal 15 = ignition ON = ready for operation; also referred to as “switched positive”
- > Terminal 50 = start motor = drive system active

Schematic diagram on activation of terminal control

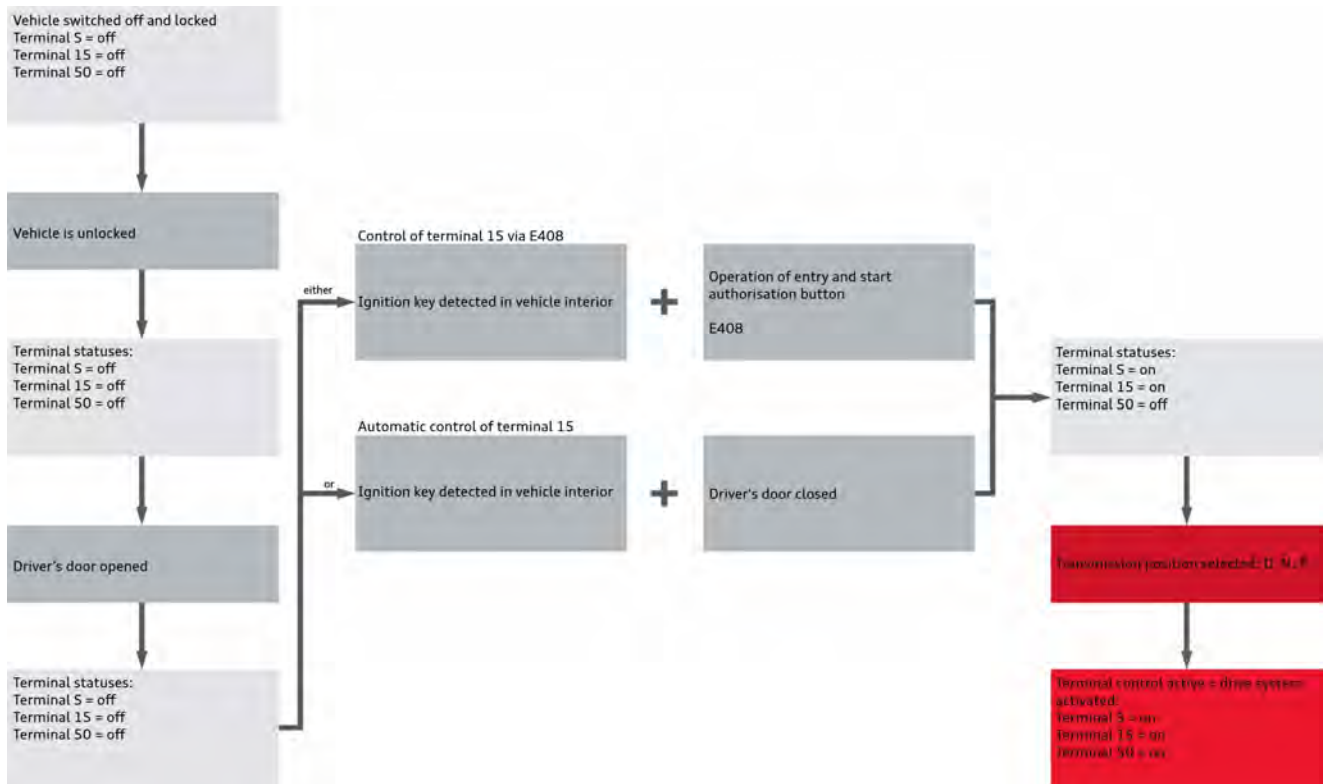

684_233

Schematic diagram on deactivation of terminal control

Various scenarios can also be used to deactivate the individual terminals. At the end, the individual terminals 50, 15 and S are off.

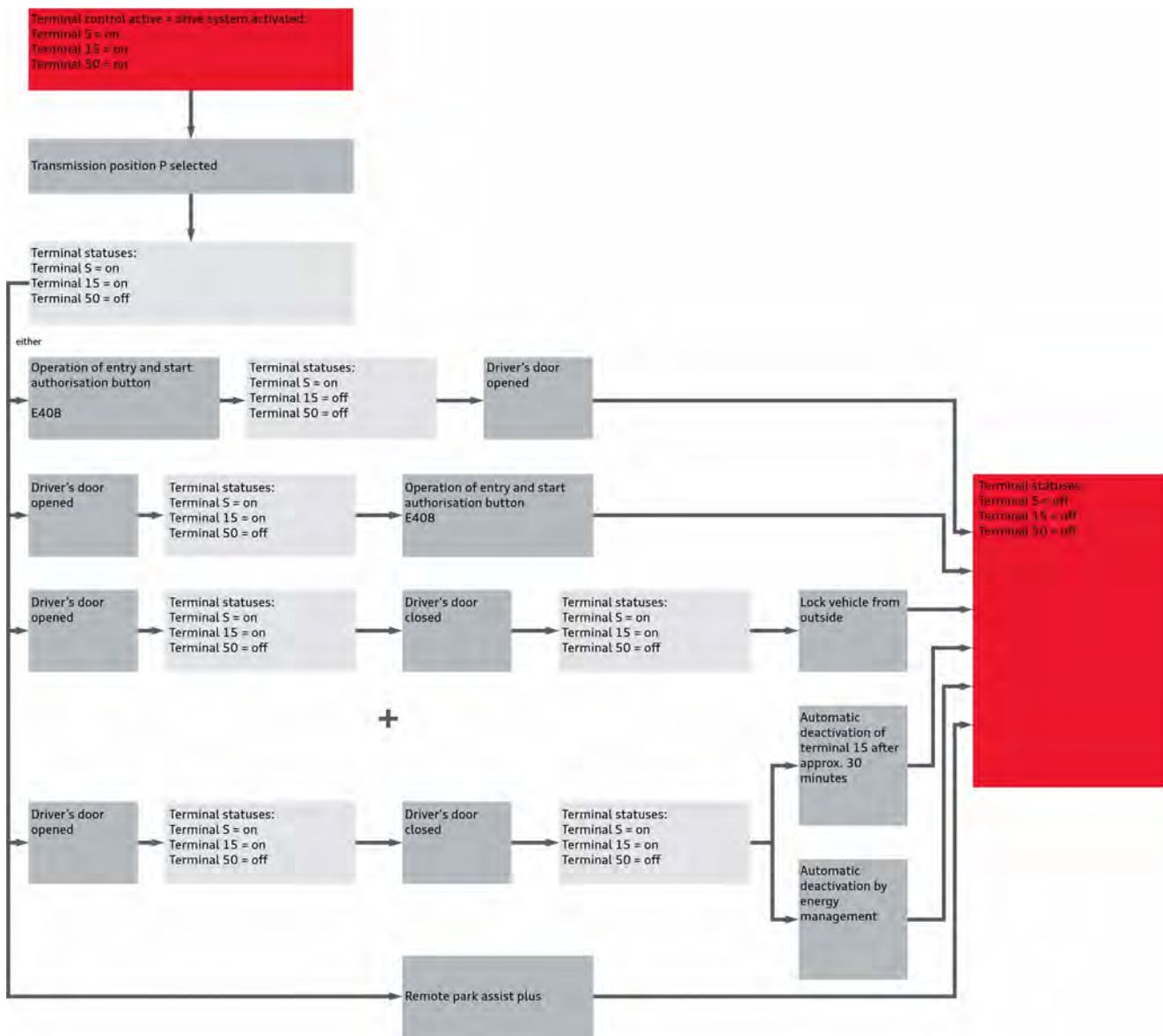

684_234

Exit concept on the Audi e-tron GT (type F8)

As on other models, the main role of the exit concept on the Audi e-tron GT is to prevent the vehicle from accidentally rolling away according to the operating status. On the Audi e-tron GT, the exit concept differentiates between two situations:

- > Driver is temporarily absent
- > Driver is absent for an extended period

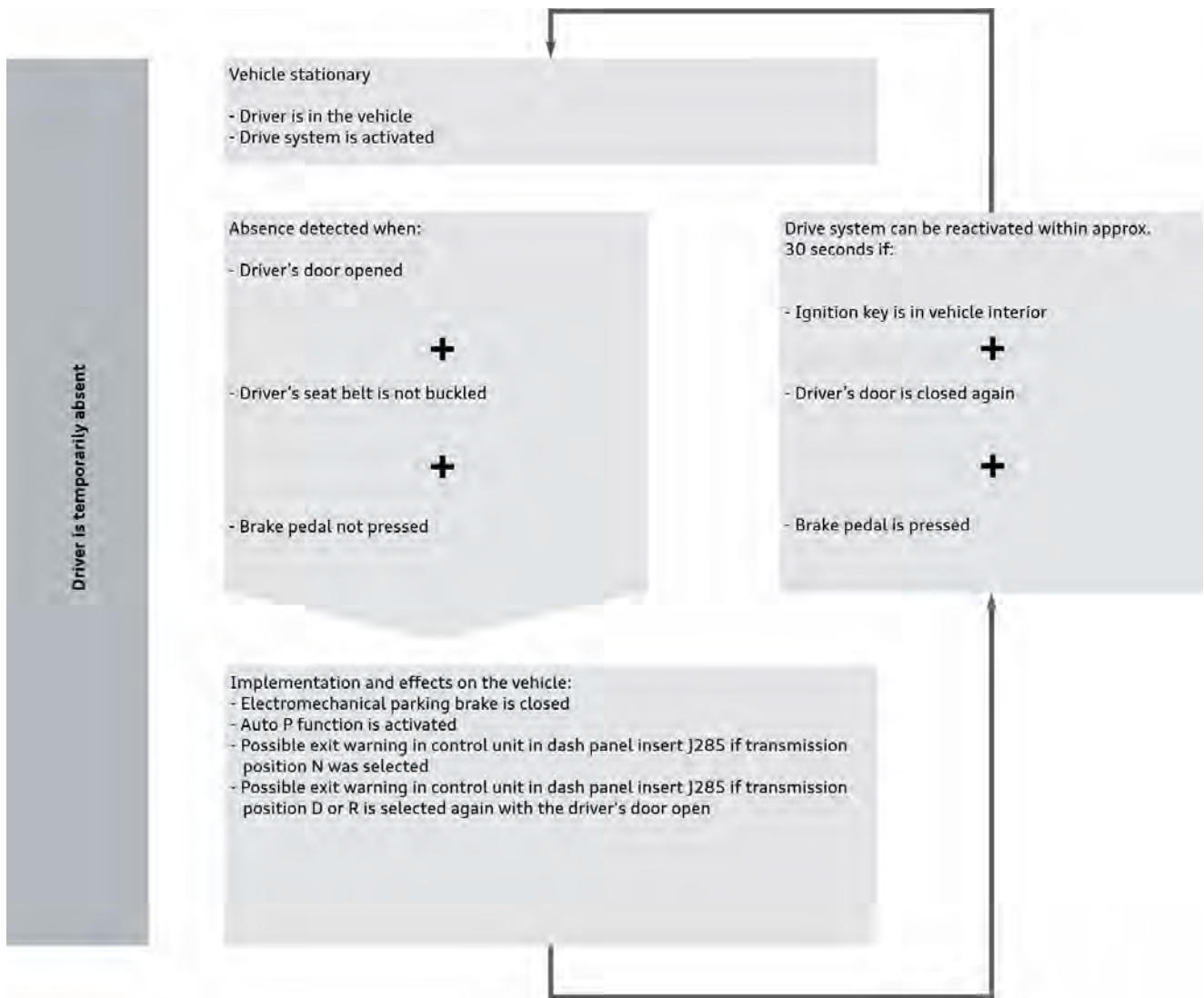

684_235

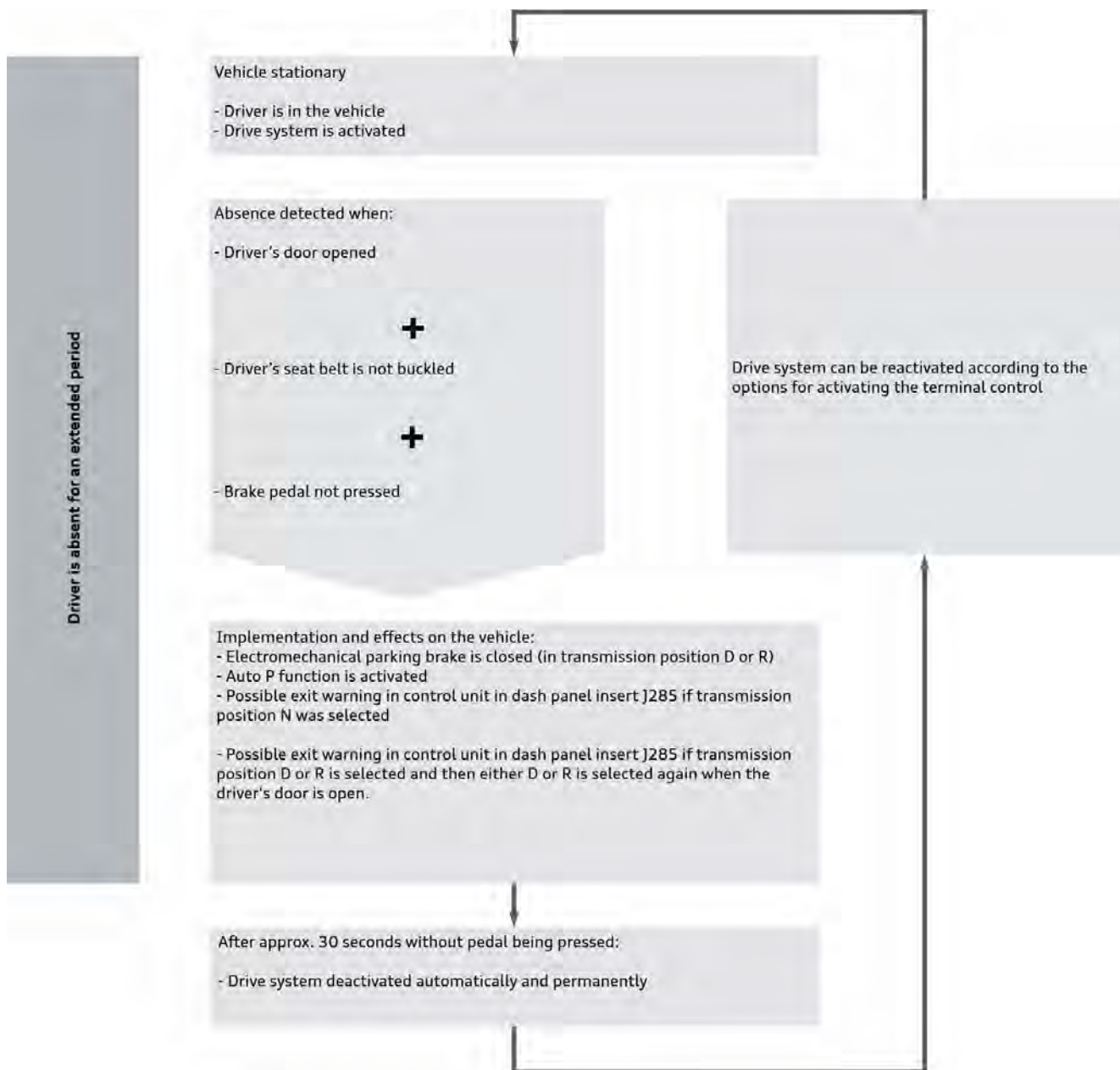

684_236

Exterior lighting

Headlights

Headlight versions

The following headlight versions are available for the Audi e-tron GT:

- > LED headlights, PR number: 8IY + 8G0/8G1/8G9 + AV1 (ECE^[6] and SAE^[7])
- > Matrix LED headlights, PR number: 8IY + 8G4 (ECE^[6])
- > Matrix LED headlights with laser main beam, PR number: 8IZ + 8G4 (ECE^[6] and SAE^[7])

PR number key:

- 8G0** Without light assist system
- 8G1** Main beam assist
- 8G4** Matrix beam
- 8G9** Light assist system pre-installation for functions on demand (FOD)

[6] ECE = for the European market

[7] SAE = for the North American market

81Y LED headlights with lens

81Z LED headlights with variable light distribution and additional laser main beam

General description

All headlight versions of the Audi e-tron GT use LEDs or laser diodes. The headlights are connected to the vehicle body by adjuster elements. This allows the headlights to be aligned exactly with the other parts of the body. Before the headlights can be removed, the bumper cover has to be detached. In the event of damage to the headlight attachments, repair tabs can be attached to the headlight housing.

LED headlights and matrix LED headlights

These two versions are physically identical and differ only in terms of how they are controlled. This means that LED headlights can be upgraded to matrix LED headlights with functions on demand (FOD). A software update purchased by the customer changes how the LEDs are controlled and activates the matrix beam function.

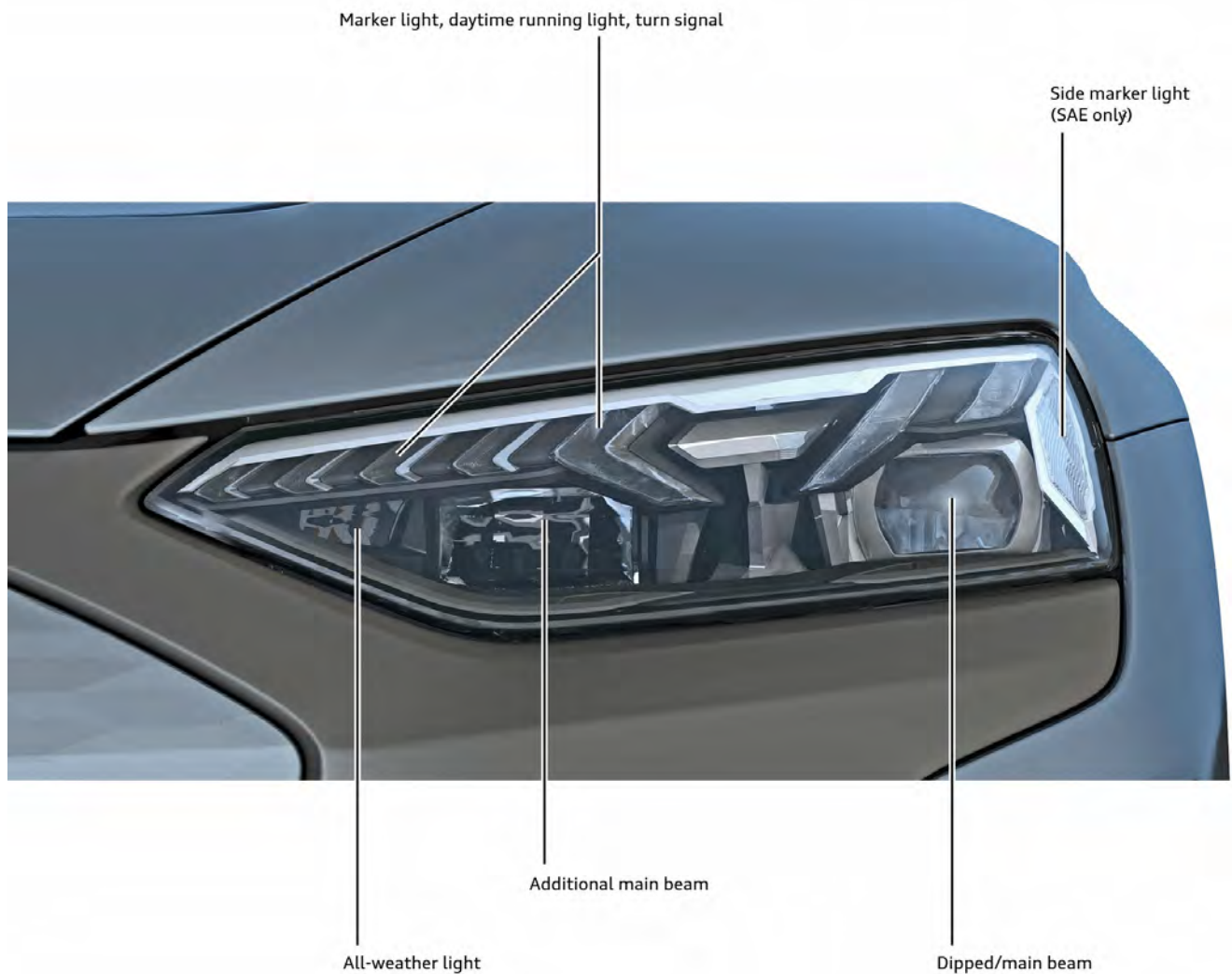

²⁾ SAE = for the North American market

684_194

LED headlights

Lighting functions

- > Daytime running lights
- > Marker lights
- > Dipped beam
- > Main beam

- > All-weather lights
- > Turn signal
- > Side marker lights (SAE^[7] only)

Special features of the lighting functions

On the ECE^[6] version, the marker lights/daytime running lights are switched off when the turn signal is on. On the SAE^[7] version, a distinction is made between “signalling by day” and “signalling by night”. When “signalling by day” the marker lights/daytime running lights are switched off and when “signalling by night” the daytime running lights are dimmed to marker light level.

Regardless of market, the all-weather lights are deactivated when the headlight flasher/main beams are activated.

Adjusting headlights for driving on other side of road

It is not necessary to adjust the headlights. The legal requirements are met without additional measures.

When driving on motorways, the dipped beam headlights setting should be selected at the light switch. This stops the light level from being raised by the headlight range control and thereby prevents you from dazzling oncoming road users.

Equipment

The LED headlights can be combined with the main beam assist as an option.

Headlight range control

The LED headlights are equipped with automatic dynamic headlight range control.

Matrix LED headlights

Lighting functions

- > Daytime running lights
- > Marker lights
- > Dipped beam
- > Matrix beam main beam
- > Dynamic turn signal
- > All-weather lights
- > Static turning light
- > Intersection light (in combination with navigation system)
- > Motorway light
- > Static cornering light
- > Side marker lights (SAE only ^[7] , not illustrated)

Special features of the lighting functions

On the ECE^[6] version, the marker lights/daytime running lights are switched off when the turn signal is on. On the SAE^[6] version, a distinction is made between “signalling by day” and “signalling by night”. When “signalling by day” the marker lights/daytime running lights are switched off, while when “signalling by night” the daytime running lights are dimmed to marker light level.

Regardless of market, the all-weather lights are deactivated when the headlight flasher/main beams are activated.

Adjusting headlights for driving on other side of road

It is not necessary to adjust the headlights. The legal requirements are met without additional measures.

When driving on motorways, the dipped beam headlights setting should be selected at the light switch. This stops the light level from being raised by the headlight range control and thereby prevents you from dazzling oncoming road users.

Headlight range control

The matrix LED headlights are equipped with automatic dynamic headlight range control.

[7] SAE = for the North American market

[6] ECE = for the European market

LED headlights and matrix LED headlights

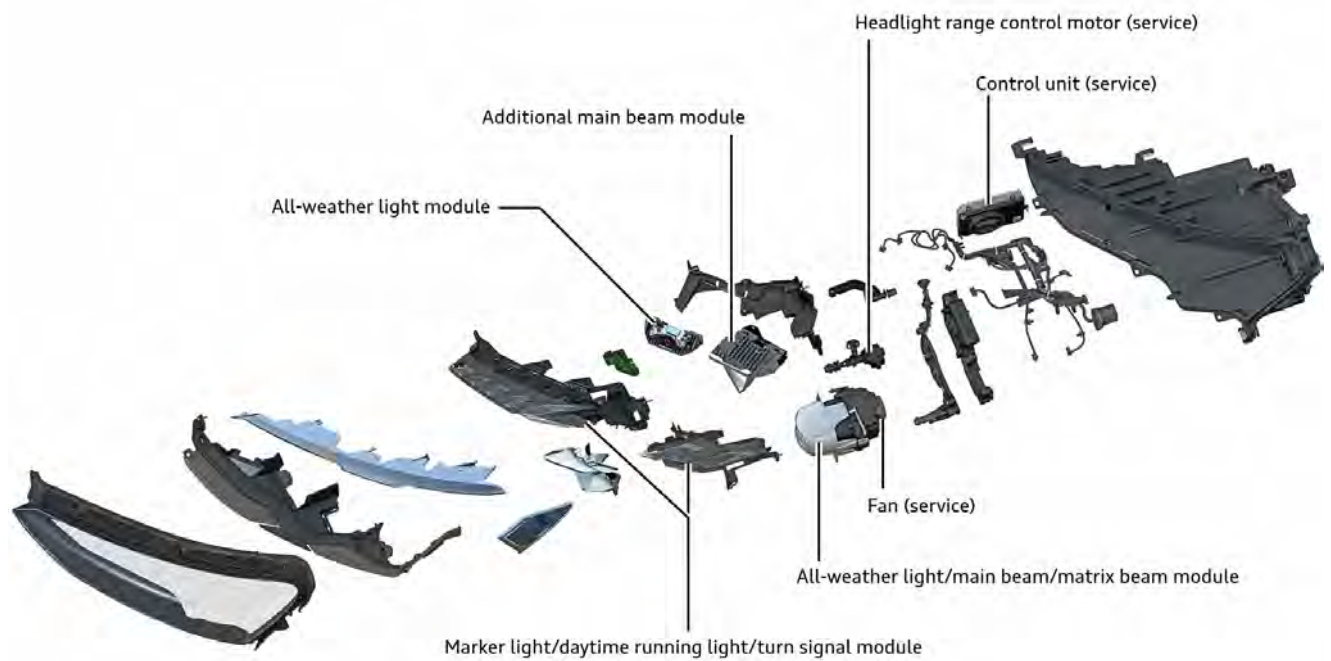

684_257

Service

The parts marked with “service” in the exploded view of the headlight can be replaced individually in the event of damage. In addition, the housing cover with seal, the seal on the top and outside of the headlight sealing disc, adjuster screws, body adjuster elements and securing bolts are available as replacement parts. In the event of damage to the upper and inner headlight attachments, repair tabs can be attached to the headlight housing. They are listed as a repair kit in the Electronic parts catalogue (ETKA).

It is very important to keep the inside of the headlight as clean as possible when renewing components in the inside of the headlight. It is also recommended to use the ESD workplace VAS 6613 to prevent electrostatic discharge.

Matrix LED headlights with laser main beam

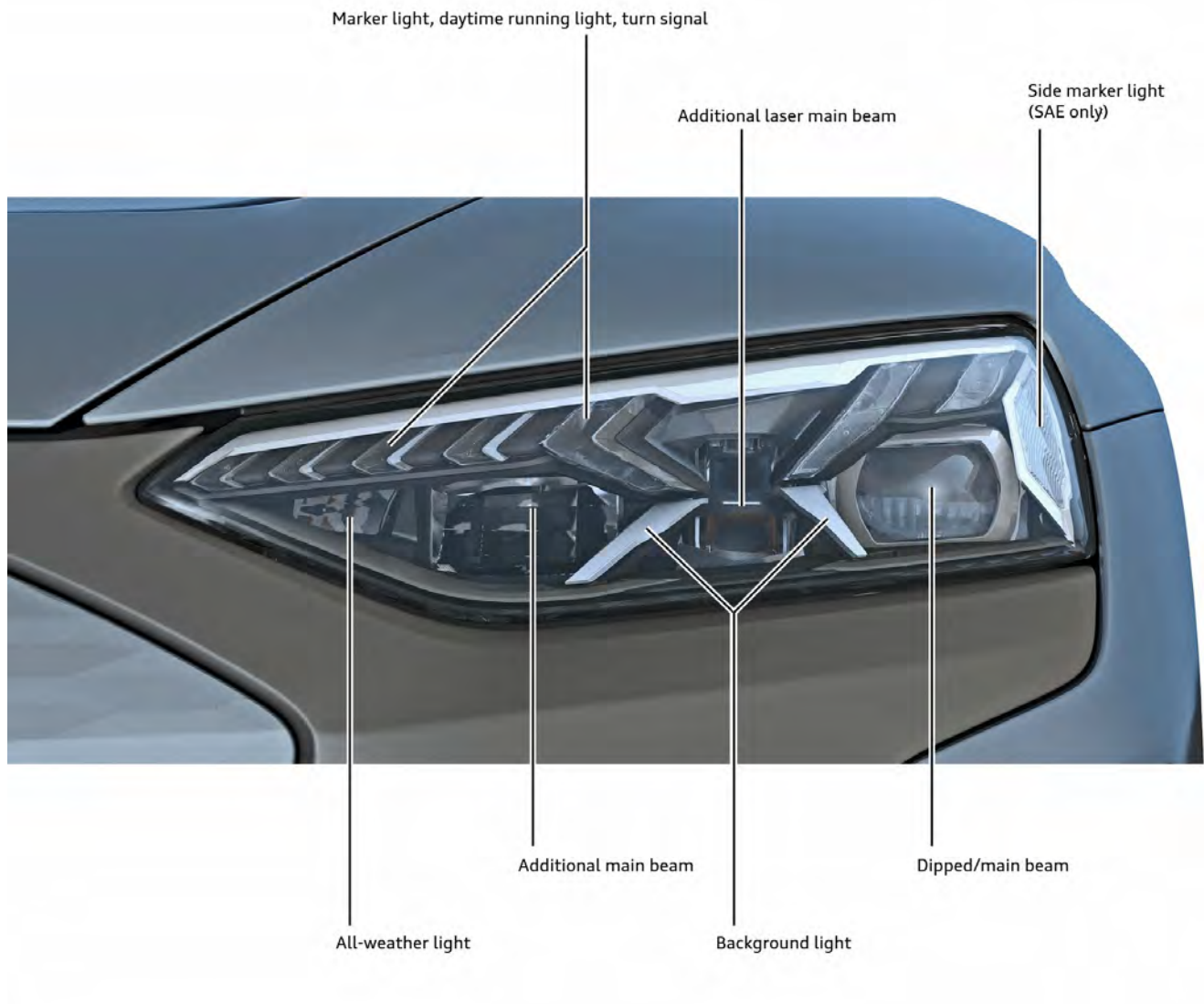

¹⁾ SAE = for the North American market

684_256

Lighting functions

- > Daytime running lights
- > Marker lights
- > Dipped beam
- > Matrix beam main beam
- > Additional laser main beam
- > Dynamic turn signals
- > All-weather lights
- > Background light; blue on ECE^[6] version, white on SAE^[7] version
- > Static turning light
- > Intersection light (in combination with navigation system)
- > Motorway light
- > Dynamic cornering light
- > Side marker lights (SAE only ^[7], not illustrated)

Special features of the lighting functions

[6] ECE = for the European market

[7] SAE = for the North American market

The background light is operated together with the marker lights/daytime running lights. On the ECE^[6] version, the marker lights/daytime running lights and the background light are switched off when the turn signal is on. On the SAE^[7] version, the daytime running lights are dimmed to marker light level when the turn signal is on but are undimmed again during the turn signal's dark phase. Regardless of market, the all-weather lights are deactivated when the headlight flasher/main beams are activated.

Adjusting headlights for driving on other side of road

It is not necessary to adjust the headlights. The legal requirements are met without additional measures.

When driving on motorways, the dipped beam headlights setting should be selected at the light switch. This stops the light level from being raised by the headlight range control and thereby prevents you from dazzling oncoming road users.

Headlight range control

The matrix LED headlights with laser main beam are equipped with automatic dynamic headlight range control.

Headlight

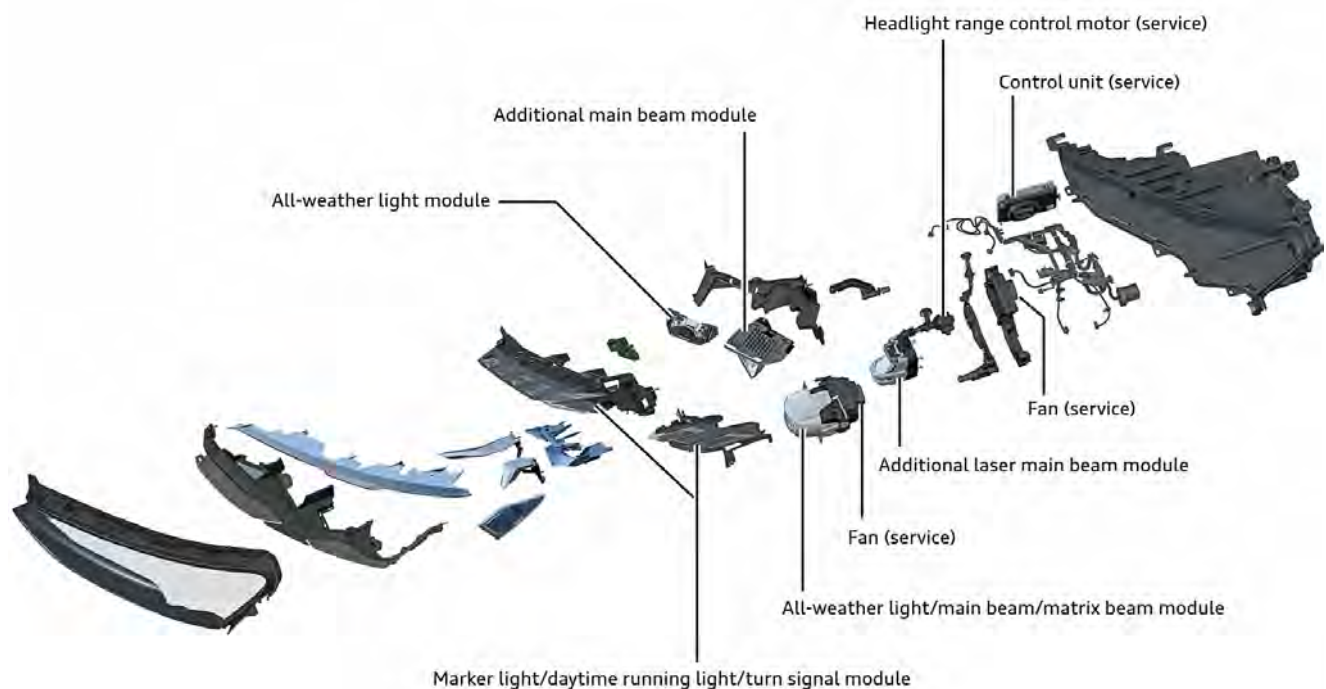

684_258

Service

The parts marked with “service” in the exploded view of the headlight can be replaced individually in the event of damage. In addition, the housing cover with seal, the seal on the top and outside of the headlight sealing disc, adjuster screws, body adjuster elements and securing bolts are available as replacement parts. In the event of damage to the headlight attachments, repair tabs can be attached to the headlight housing. They are listed as a repair kit in the Electronic parts catalogue (ETKA).

It is very important to keep the inside of the headlight as clean as possible when renewing components in the inside of the headlight. It is also recommended to use the ESD workplace VAS 6613 to prevent electrostatic discharge.

Service/adjustment and calibration (applies to all headlight versions on the Audi e-tron GT)

As on all headlights in Audi vehicles, the dipped beams are adjusted using two adjuster screws. However, the matrix beam main beams on the Audi e-tron GT are not calibrated by measuring a reference segment. On the headlights of the Audi e-tron GT, the inflection point of the dipped beam is measured. These values are entered in the test program of the diagnostic tester and the correction value for the matrix beam main beams is calculated.

[6] ECE = for the European market

[7] SAE = for the North American market

**Note**

The headlight versions available vary from market to market. This is not the topic of the descriptions on this page. A new light switch and thereby a new operating concept was introduced with the Audi A8 (type 4N). This concept is also used for the Audi e-tron GT. The operating concept allows, for example, the dipped beam headlights and the day-time running lights to be switched off at speeds below 10 km/h. If this speed is exceeded, the light switch changes to the "AUTO" position. Furthermore, the light switch is always in the "AUTO" position after the ignition has been switched off and on again, regardless of what was selected prior to the ignition being switched off.

Tail lights

Tail light versions

The following tail light versions are available for the Audi e-tron GT:

- › Tail lights, PR number: 8VM (ECE^[6] and SAE^[7])
- › Tail lights, PR number: 8VM + 8VP (ECE^[6] and SAE^[7])

PR number key:

8VM	LED tail lights with dynamic turn signals
8VP	LED tail lights with animated lighting functions

The tail lights on the Audi e-tron GT are in three sections; one tail light each on the left and right sides and a light unit which covers the entire width of the boot lid. Only LED lights are used. The tail lights and the high-level brake light are activated by convenience system central control unit J393.

[6] ECE = for the European market

[7] SAE = for the North American market

High-level brake light

On the Audi e-tron GT, the high-level brake light is fitted behind the rear window. On vehicles with privacy glass (PR number: QL5), the LEDs are activated with a higher current. This must be taken into account when renewing the high-level brake light. It is not possible to replace individual LEDs.

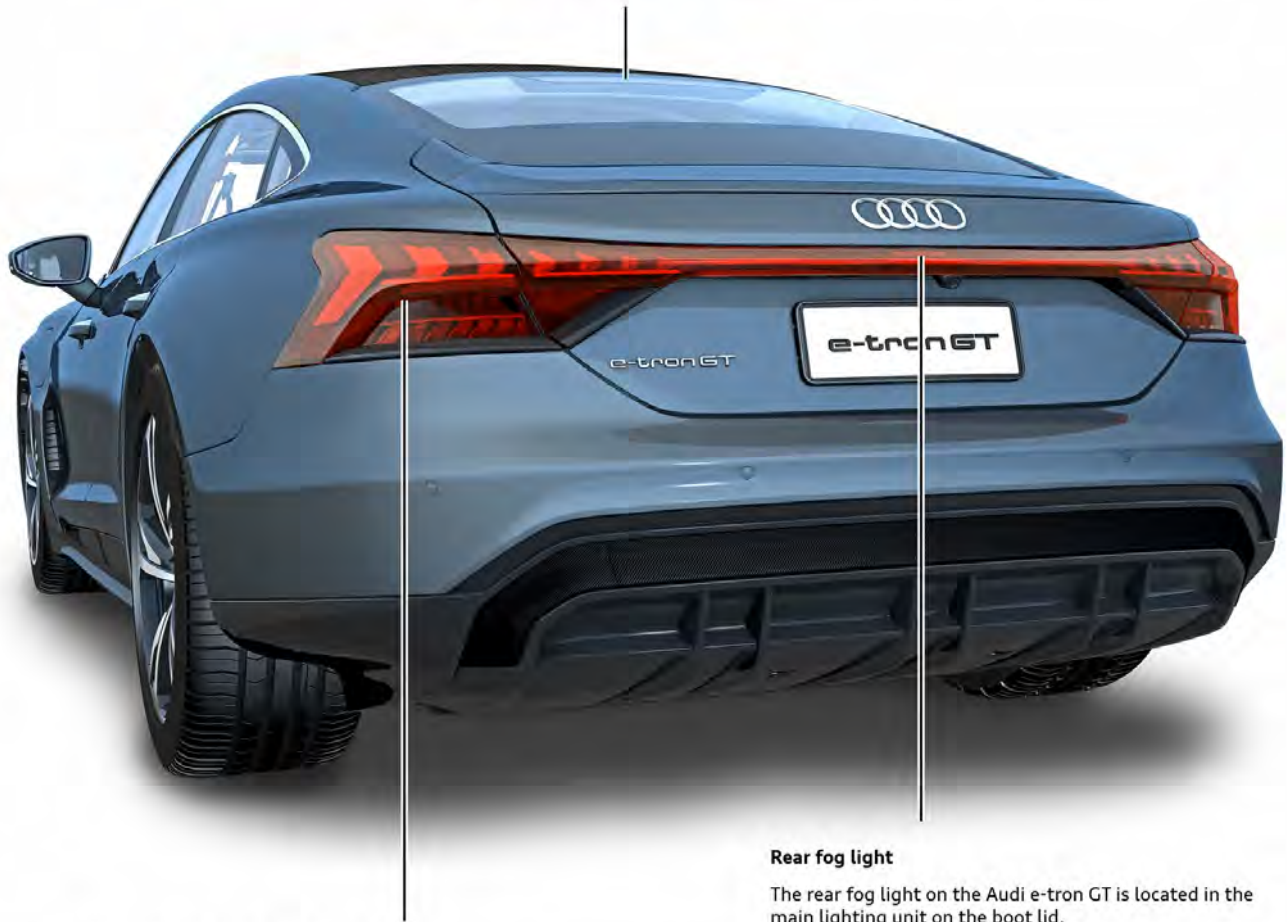

Rear fog light

The rear fog light on the Audi e-tron GT is located in the main lighting unit on the boot lid.

Lighting functions in the tail lights

The tail light, turn signal and brake light functions are split between the three tail light sections. The reversing light is fitted in the tail light cluster on the rear lid on both sides.

The tail light functions on the Audi e-tron GT include a dynamic turn signal and, on versions with PR number 8VP, dynamic lighting effects for the tail light. Due to country-specific regulations, the turn signal and brake light functions differ on the ECE¹ and SAE² versions.

¹ ECE = for the European market

² SAE = for the North American market

Convenience electronics

Control unit for head-up display J898

The hardware of control unit for head-up display J898 is taken from the Porsche Taycan. Useful information is projected into the driver's field of vision in full colour. The projection is such that the information appears to be approximately 3 metres ahead of the driver.

On the Audi e-tron GT (type F8), the networking is based on the MLBevo2 platform. This means that, as on other models that use the platform, the head-up display on the Audi e-tron GT (type F8) communicates with the other control units in the vehicle via the instrument cluster CAN data bus. Larger volumes of data are transmitted via the Ethernet cable, which is a single twisted-pair copper cable.

The Ethernet connection is used to transmit navigation data such as the bar graph views or the detailed intersection map.

The display is divided into the main area, the status area and an area for temporary content. The content shown is specific to the Audi e-tron GT (type F8), but there are strong similarities to the content displayed on an Audi A6 or Audi A8.

Unlike control unit in dash panel insert J285, control unit for head-up display is not a node of the component protection system. It can be accessed via diagnostic address 0082 on the vehicle diagnostic tester.

There will not be a calibration board for adjusting the eye box in the workshop, as all the necessary adjustments (e.g. changes in height or corrections to the angle of the image) can be made by changing the settings in an MMI menu.

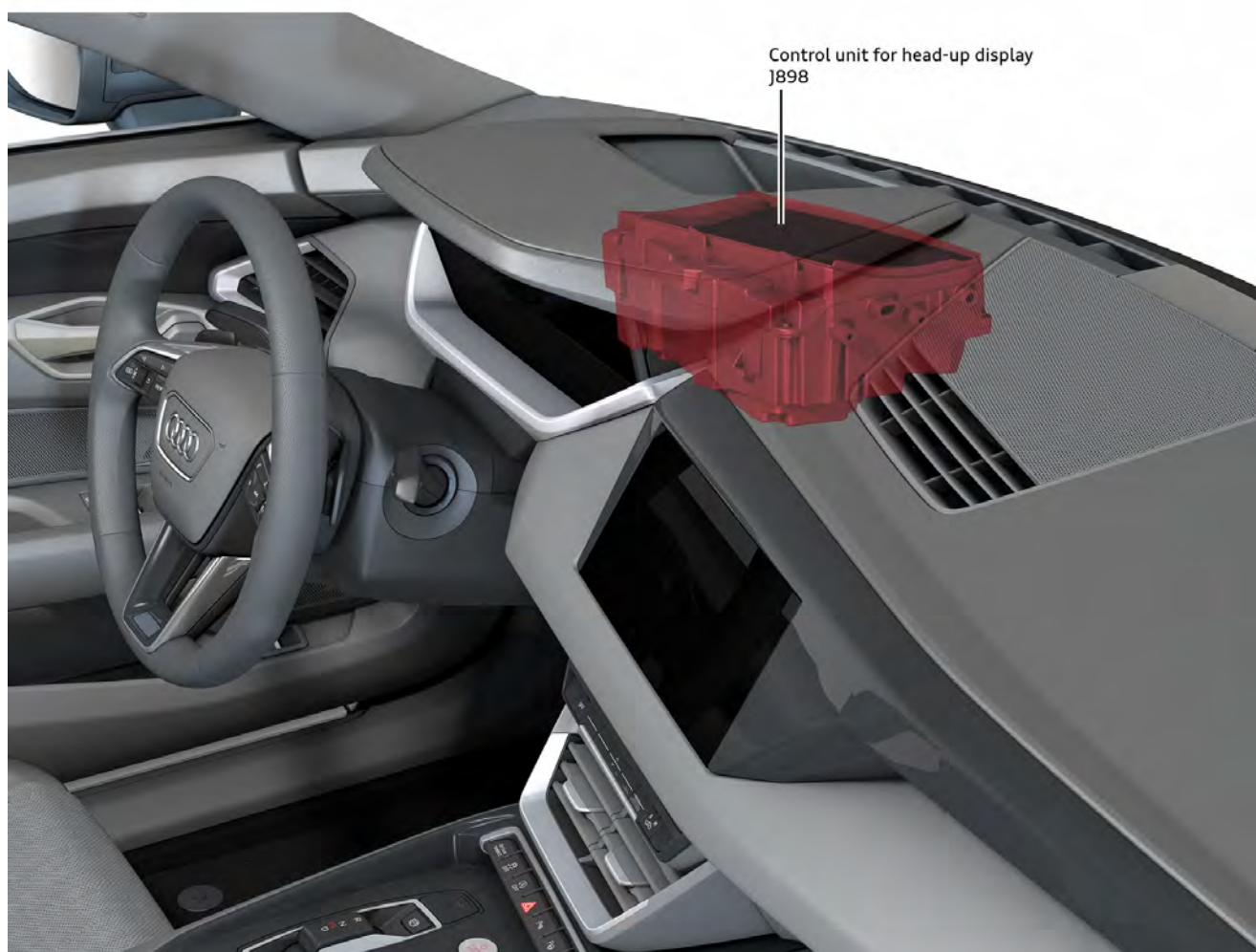

684_317

Convenience system central control unit J393

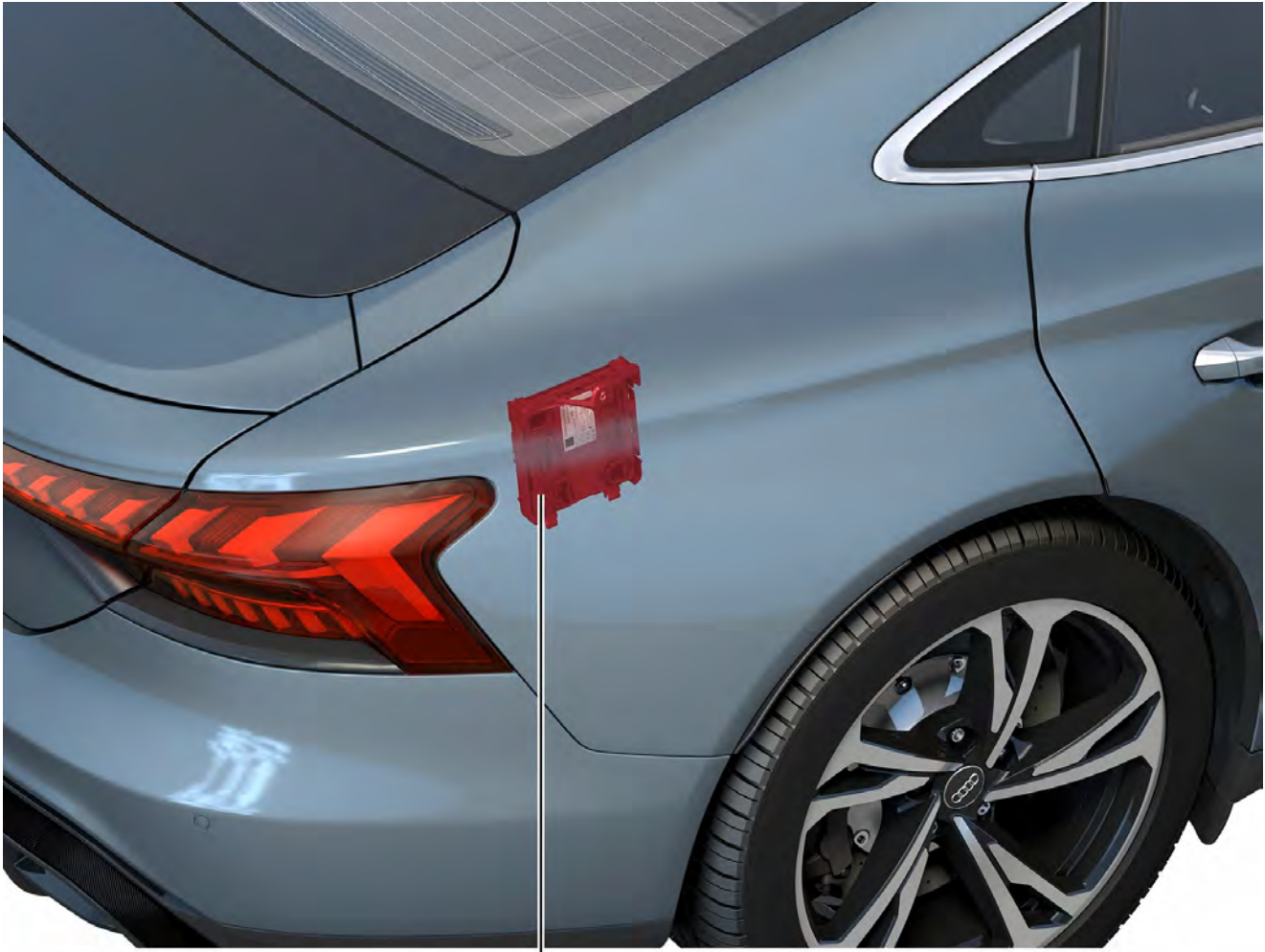

Convenience system central control unit
J393

684_319

Convenience system central control unit J393 is fitted on the right-hand side in the luggage compartment. It is positioned vertically on the Audi e-tron GT (type F8).

As on other Audi models whose electrical systems are based on the MLBevo2 platform, convenience system central control unit has many tasks.

J393 is the master control unit for the immobiliser. The following control units are also immobiliser nodes:

- › Data bus diagnostic interface J533
- › Electric drive control unit for front axle J1234
- › Electric drive control unit for rear axle J1235
- › Emergency call module control unit and communication unit J949
- › Gear actuator VX65

Additional functions and tasks of convenience system central control unit J393:

- › Component protection system node
- › Can be accessed via diagnostic address 0046 on the vehicle diagnostic tester
- › J393 is the LIN master for:
 - › Central locking system – radio signals from the remote control key and signals from the interior antennas are processed
 - › Anti-theft alarm – data from the tilt sensor are processed and, when the alarm is triggered, alarm horn H12 is activated
 - › Rear lid power opening sender G750
- › Master control unit for entry and start authorization system – e.g. the remote control keys are adapted in convenience system central control unit

Front seats

Three different front seats are available on the Audi e-tron GT (type F8). There is a wide range of customisation options for these three seats. For further information on the different customisation options, please refer to the sales literature once it is available.

Even the basic seat for the Audi e-tron GT (type F8) is equipped with electrical seat adjustment with a total of eight settings. The comfort seat, which has 14 settings, is the basic option for the RS e-tron GT. This seat can also be ordered with optional pneumatically adjustable side bolsters, in which case it has 18 settings and is called a sports seat.

Audi e-tron GT sports seat with 8 settings



684_159_C

The different front seats and customisation options are summarised in the following table:

Seat/equipment	Basic seat (8 settings)	Comfort seat (14 settings)	Sports seat (18 settings)
Electric height adjustment	✓	✓	✓
Electric backrest rake adjustment	✓	✓	✓
Electric seat cushion rake adjustment	✓	✓	✓
Electric longitudinal seat adjustment	✓	✓	✓
Manual seat belt height adjustment	✓	✓	✓
Manual head restraint adjustment	✗	✗	✗
Four-way lumbar support	✗	✓	✓
Pneumatic side bolster adjustment	✗	✗	✓
Electric seat depth adjustment	✗	✓	✗
Driver's seat memory	Optional	Optional	Optional
Front seat ventilation	✗	✗	✓
Front seat massage	✗	✗	Optional

Seat/equipment	Basic seat (8 settings)	Comfort seat (14 settings)	Sports seat (18 settings)
Front seat heating	Optional	✓	✓
Coloured seat seams (RS design package)	✗	✗	Optional

Key

- ✓ Available
- ✗ Not available

The technology of the front seat massage, pneumatic lumbar support and pneumatic side bolsters is the same technology which has been in use for some time in models such as the Audi A8 (type 4N).

Audi RS e-tron GT sports seat with 18 settings



684_159_RS

Control unit in dash panel insert J285

e-tron Sport display with central power meter



684_276

e-tron Sport display focused on range and electric driving



684_346

The Audi e-tron GT (type F8) is fitted with the Audi virtual cockpit plus as standard. On the Audi e-tron GT (type F8), this instrument cluster allows the customer to choose between three different displays:

- > Classic
- > Sport
- > e-tron Sport

The familiar VIEW button on the multifunction steering wheel enables the driver to select either the display mode with large round instruments or the mode with smaller instruments.

Selecting the smaller instruments allows the customer to focus on a larger infotainment display in the instrument cluster, for example.

Interior lighting

The Audi e-tron GT (type F8) can be fitted with the background lighting package (PR number QQ2) as optional equipment. Unlike other Audi models, the Audi e-tron GT only has surface lighting in the interior and does not have contour lighting. As on various other Audi models, if this equipment is fitted, surfaces such as the doors are highlighted by LEDs. The brightness and colour of the LEDs can be adjusted in the MMI menu.

Background lighting, PR number: QQ2

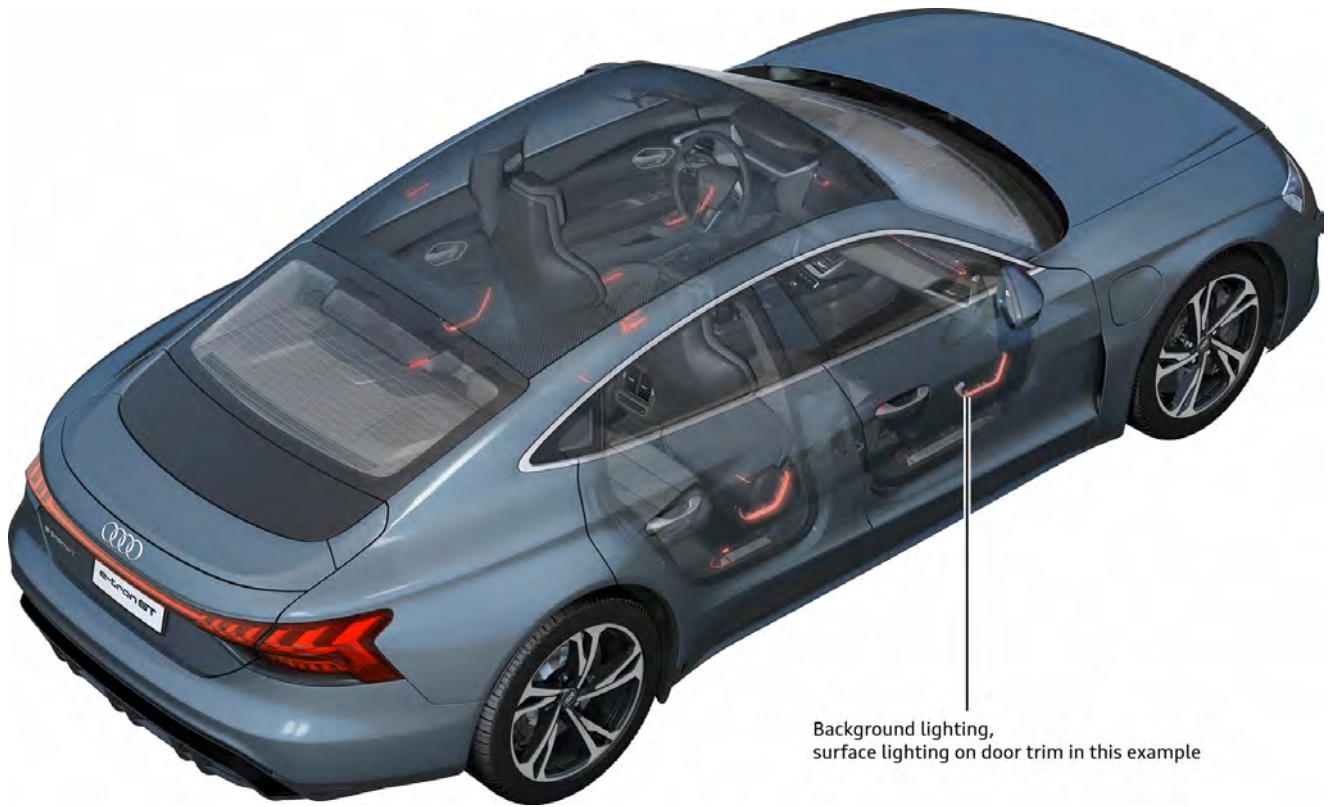

Background lighting,
surface lighting on door trim in this example

684_274

Depending on the infotainment system fitted, the edges of the loudspeakers can also be lit up on vehicles equipped with PR number QQ2.

Only LEDs are used.

Central locking system with convenience key

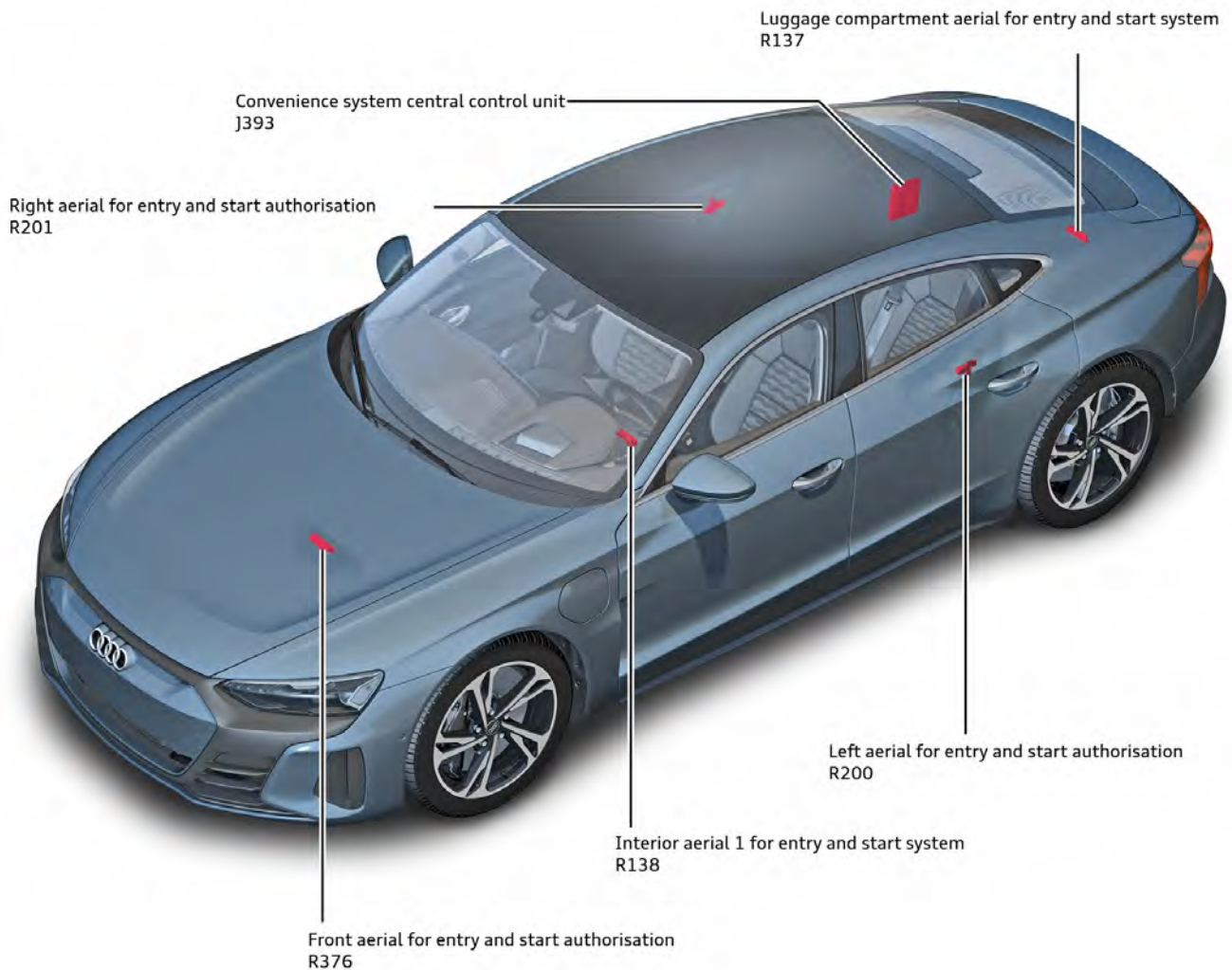

684_240

The central locking system with remote control is standard equipment on the Audi e-tron GT and works in the same way as on the other Audi models that are based on the MLBevo2 platform. For example, the reception antenna for the remote control is also located on the printed circuit of convenience system central control unit J393 on the Audi e-tron GT.

Vehicles with the convenience key have a fifth Kessy antenna. Front antenna for entry and start authorization R376 is fitted at the rear of the front compartment.

This antenna was first introduced with the launch of the Audi A8 (type 4N), although it was later discontinued in that model. On the Audi e-tron GT, this antenna is fitted on all vehicles that are equipped with the convenience key. Diagnosis of R376 is possible with the vehicle diagnostic tester. The antenna is active for the convenience key function. Front antenna for entry and start authorization R376 is required for the remote park assist plus, which is being introduced with the Audi e-tron GT.



Reference

Additional information can be found in this SSP (refer to article "Remote park assist plus").

High-voltage system

Safety regulations

Direct current of up to approx. 800 Volts is present in the high-voltage system.

Please note:

The high-voltage system may also be energised when the vehicle is parked. For example:

- > When the high-voltage battery is being charged.
- > When auxiliary air conditioning is active.
- > When the 12 Volt battery is being recharged by the high-voltage battery.

Work on components of the vehicle's high-voltage system must only be performed when the system is not energised. To achieve this, the high-voltage system must be de-energised and the mechanic must then check that the system is de-energised. The de-energisation procedure is performed according to the five safety rules for electrical technology.

These three work steps must be performed:

- 1 De-energise the system
- 2 Ensure the system cannot be reactivated
- 3 Check that no voltage is present

These two work steps are not relevant for high-voltage vehicles:

- 4 Ground and short-circuit vehicle
- 5 Cover or shield adjacent live components



Note

Alternating voltage of 25 Volts and above and direct voltage of 60 Volts and above are hazardous to human beings. It is therefore crucial to follow the safety instructions given in the service literature and Guided Fault Finding, as well as the warnings displayed on the vehicle.



Note

Always de-energise the system according to the test plan in the vehicle diagnostic tester. The high-voltage system must only be de-energised and worked on by qualified staff.

Warning labels

Warning label in motor compartment

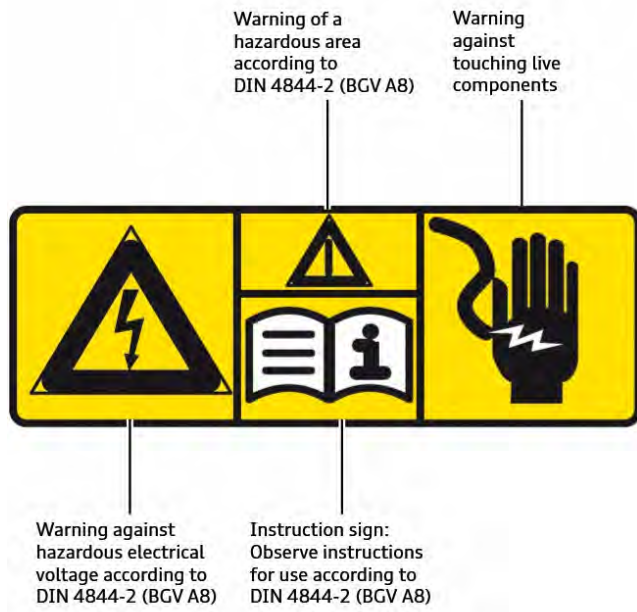

684_422

The warning labels marked "Danger" identify high-voltage components or components conducting high-voltage.



684_423

Special warning label for the high-voltage battery

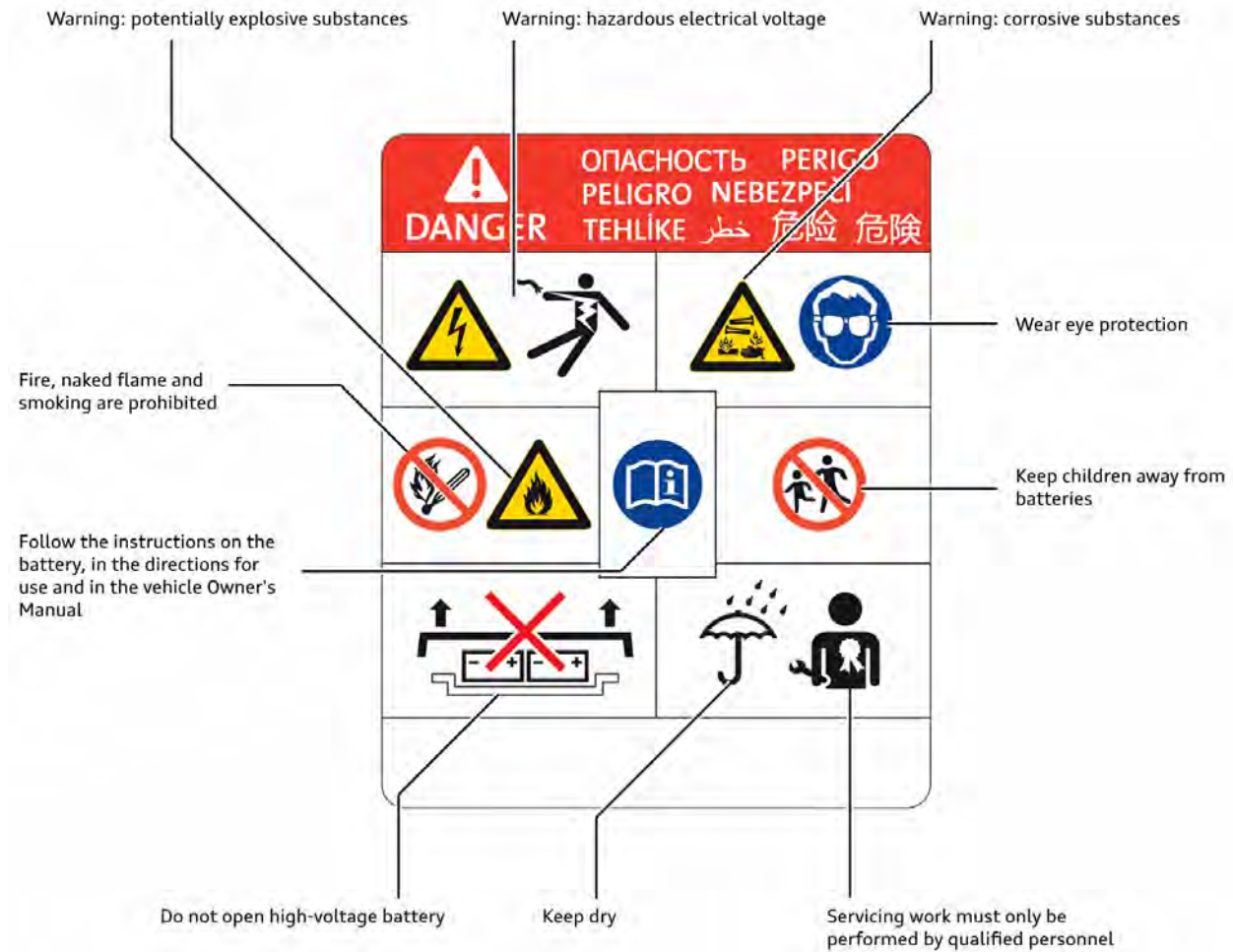

684_296

Warning labels are fitted to the vehicle to indicate the danger caused by electrical current.

These must be observed in all circumstances to avoid endangering users, workshop staff and technical & medical emergency response personnel. The general occupational health and safety regulations for work on high-voltage vehicles apply.



Note

Other/additional warning/information labels may be attached to the vehicle, depending on the country.

Overview of high-voltage components

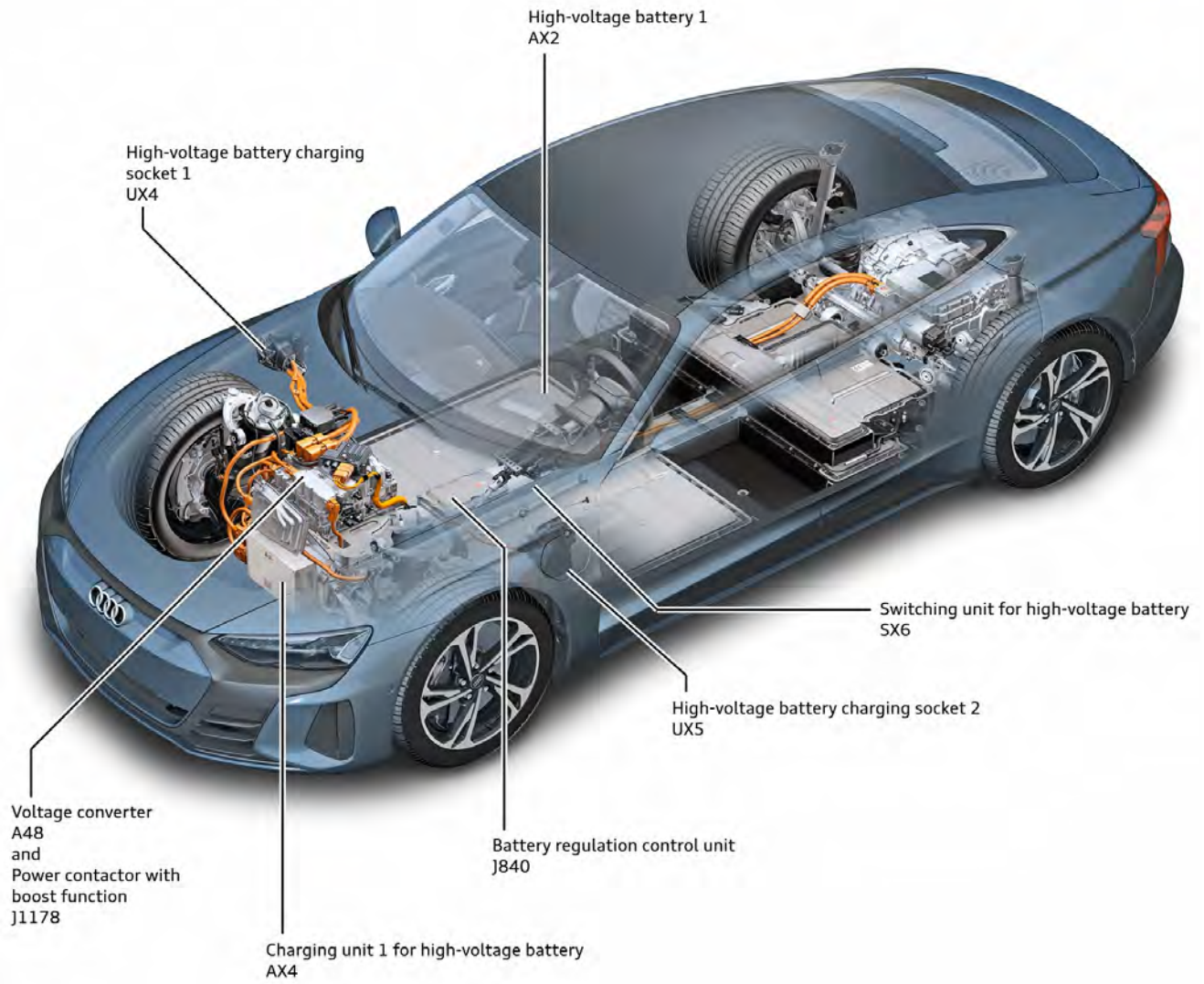

684_187

High-voltage battery AX2

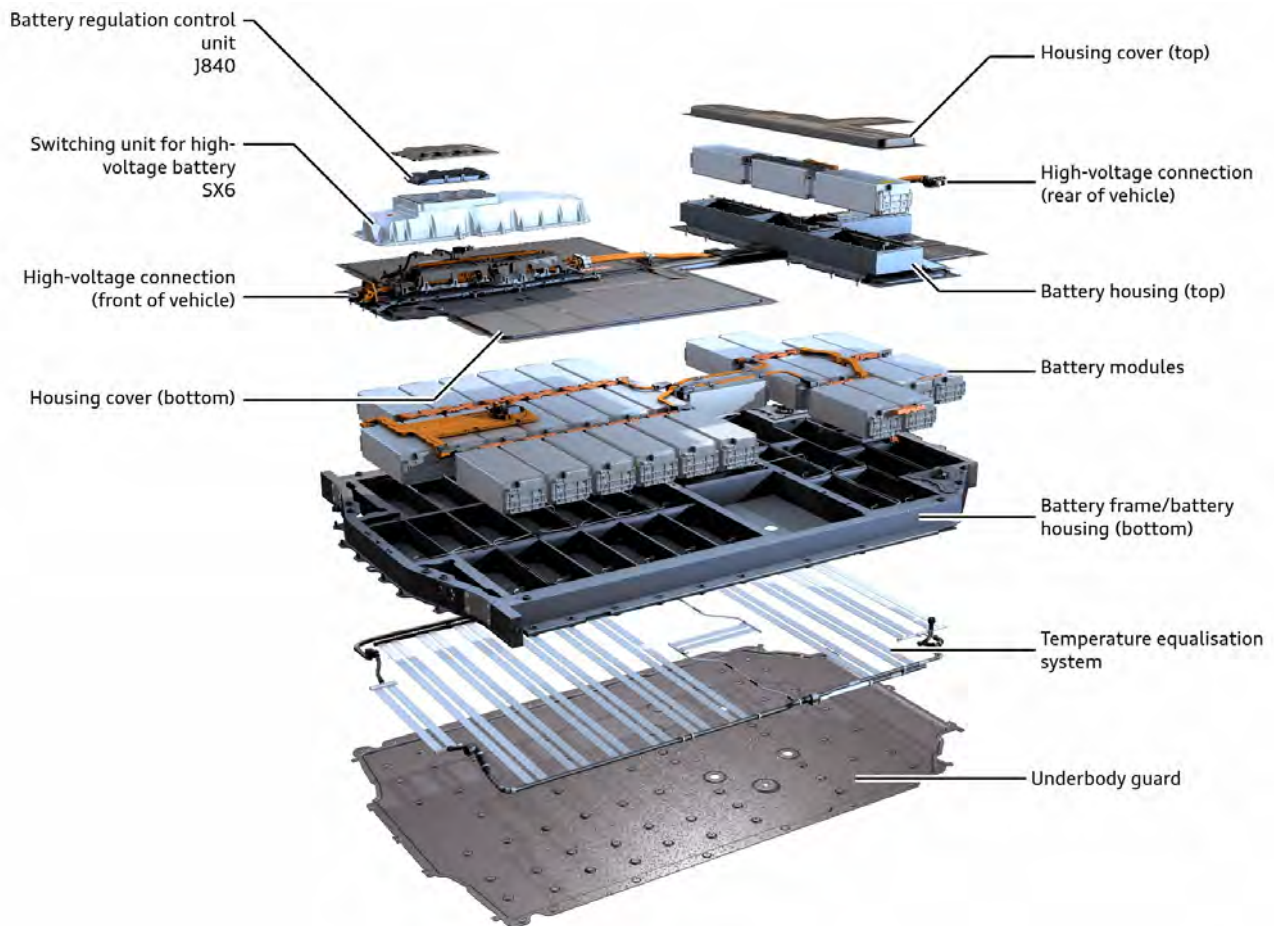

684_021

High-voltage battery 1 AX2 is bolted on centrally under the vehicle as a component supporting the body. The battery has 33 battery modules which are fitted on two levels.

The battery housing is connected to the body via a live potential equalisation line. Potential equalisation refers to a suitably conductive connection that minimises differences in electric potential.

Switching unit for high-voltage battery SX6 is fitted on the high-voltage battery. The battery module control units are fitted on the modules inside the high-voltage battery. Battery regulation control unit J840 is located in switching unit for high-voltage battery SX6.

Technical data

Designation	High-voltage battery
Cell modules	33
Cells	198s2p
Weight in kg	Approx. 650
Nominal voltage	726
Number of battery cells	396 in 33 modules
Energy content in kWh	93
Maximum charging capacity in kW	270
Approx. size in mm	2430 x 1670 x 325

If the vehicle is parked for a long period, the charge level of the high-voltage battery is reduced because the 12 Volt battery is automatically recharged. If the charge level of the high-voltage battery goes below 10%, the 12 Volt battery is no longer recharged.



Reference

Additional information can be found in this SSP (refer to article "12 Volt power supply").

Operating temperatures

The battery has an operating range between -30 °C and 50 °C.

It is not possible to activate the vehicle's drive system under -30 °C. Above 60 °C, the power contactors are opened/kept open when the ignition is on. At temperatures between 55 °C and 60 °C, the current draw of the high-voltage battery is reduced.

High-voltage batteries that are not currently installed in a vehicle may be stored at temperatures between -40 °C and 60 °C.

Cooling

The coolant circuit for the high-voltage battery provides cooling for the battery. The battery modules release heat to the battery housing via a layer of thermal grease.

The coolant in the coolant circuit for the high-voltage battery flows through heat sinks that are bonded to the battery housing with thermal conductive adhesive.

Coolant temperature sender 1 for high-voltage battery G898 and coolant temperature sender 2 for high-voltage battery G899 measure the temperature of the coolant upstream and downstream of the high-voltage battery.

The coolant in the high-voltage battery is circulated by the coolant pump for high-voltage battery V590.

If the low-temperature cooling circuit for the high-voltage battery does not provide sufficient cooling, it is possible to cool the coolant additionally using the refrigerant circuit (this takes place via the heat exchanger for high-voltage battery).

At low temperatures, the high-voltage battery can be heated up while charging via the high-voltage heaters.



Reference

Additional information can be found in this SSP (refer to article "Coolant circuit for high-voltage battery").

Battery modules

A battery module is made up of 12 pouch cells and the battery module control unit. Each of these cells has a nominal voltage of 3.65 V and a capacity of 66 Ah.



6 connections in series and 2 connections in parallel

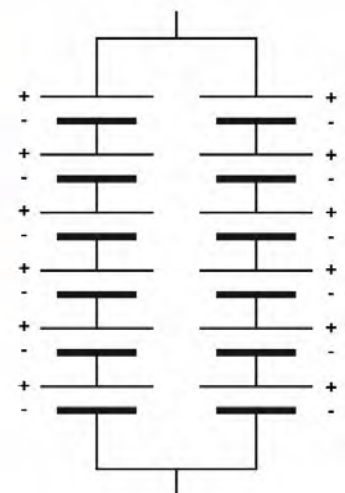

684_004

Note:

For cells connected in series, the voltages are added together; for cells connected in parallel, the capacities are added together. In the 6s2p circuit of the module, the nominal voltage of the module is 22 V, and the module capacity is 132 Ah.

Control units for battery modules

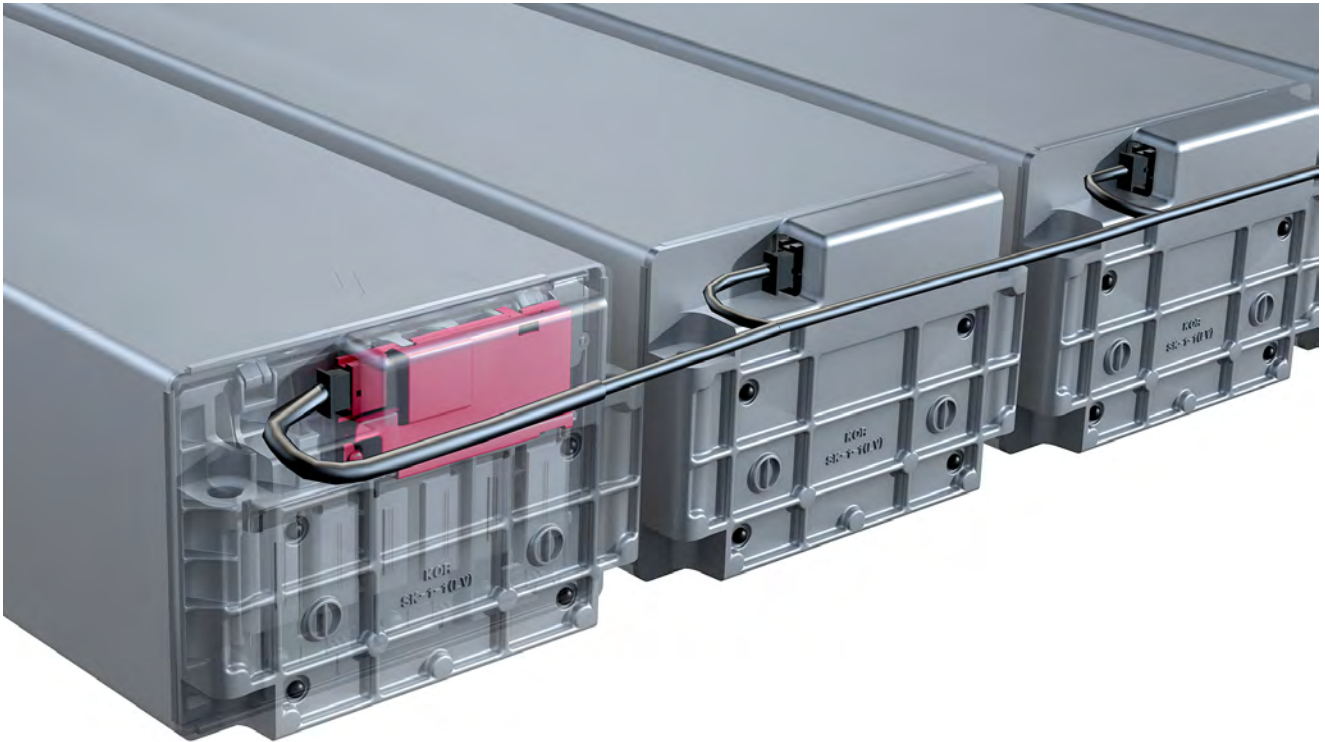

684_125

A battery module control unit is fitted on every cell module. The battery modules control unit has the following functions:

- > Measuring the voltage of six cells
- > Reading signals from two module temperature sensors and one onboard temperature sensor
- > Passive balancing (max. 100 mA)

The battery modules control unit communicates with high-voltage battery control unit J840 via a twisted-pair cable bus.

The battery modules control unit cannot be renewed individually; it must be renewed together with the battery module.

Module circuits and numbering for the lower battery level

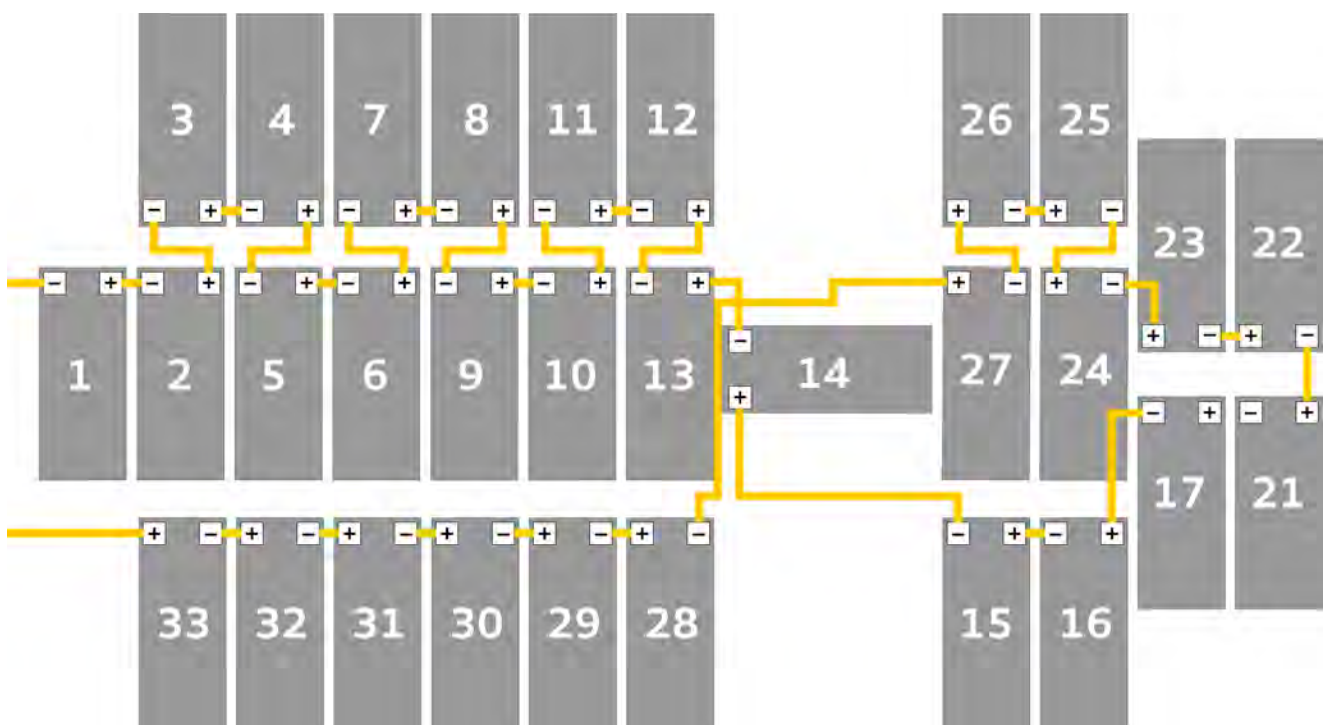

684_347

The modules are numbered from 1 to 33, beginning with the negative battery terminal; the positive terminal is number 33. In other words, the numbers go from negative to positive potential.

Module circuits and numbering for the upper battery level

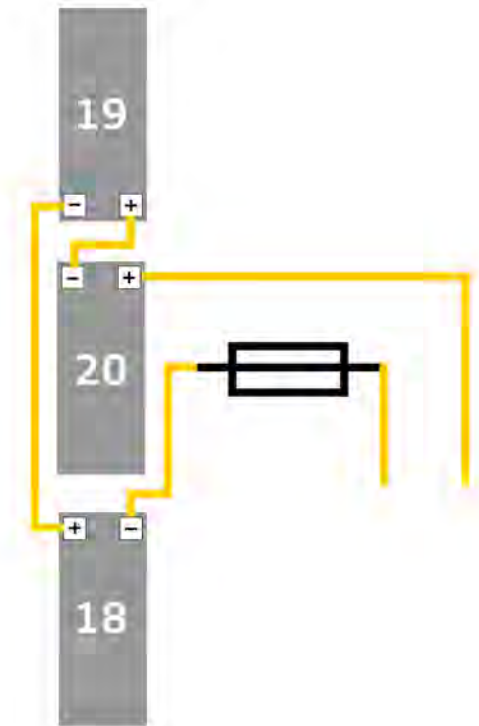

684_348

The second level contains modules 18, 19 and 20, and the high-voltage battery fuse.

Switching unit for high-voltage battery SX6

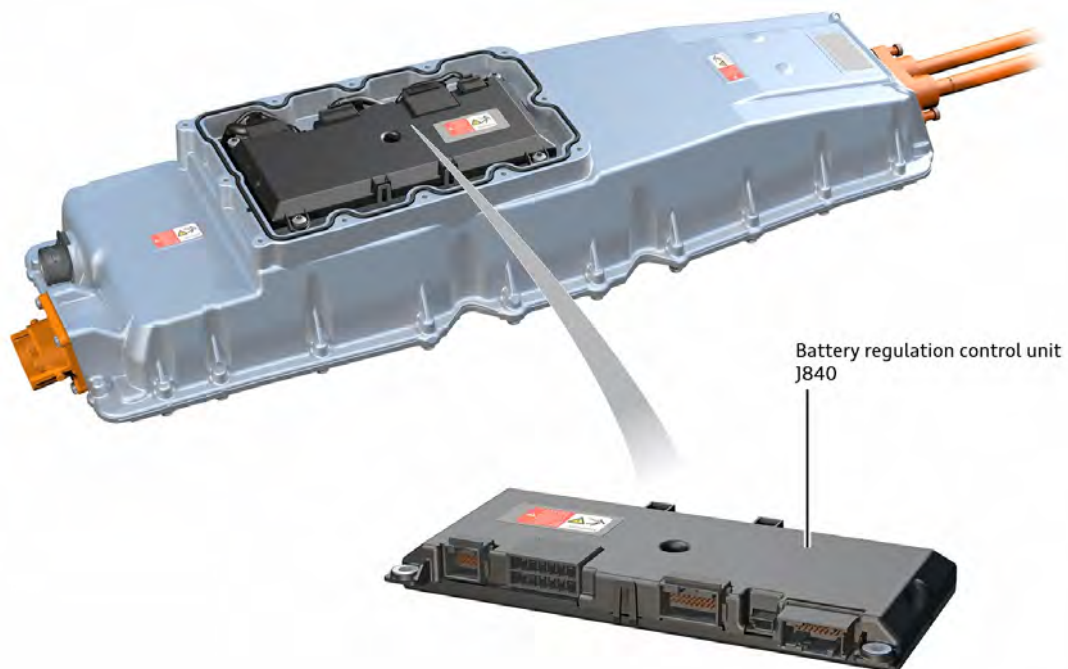

684_123

The switching unit is the divider between the high-voltage battery and the vehicle's high-voltage system. It incorporates the following components:

- > Controller for measuring current and voltage
- > Fuses for the high-voltage cables (front and rear)
- > Current sensor (Hall sensor)
- > Protective relays for high-voltage positive and high-voltage negative sides
- > Pre-charge protective relay with 30 ohms pre-charge resistance

Switching order of the protective relays when the high-voltage system is switched on:

- > High-voltage positive - vehicle front end,
- > High-voltage positive - vehicle rear end,
- > High-voltage negative - pre-charge,
- > High-voltage negative.

The protective relays are opened in reverse sequence of the switching order; only if triggered by a crash are they all opened at the same time.

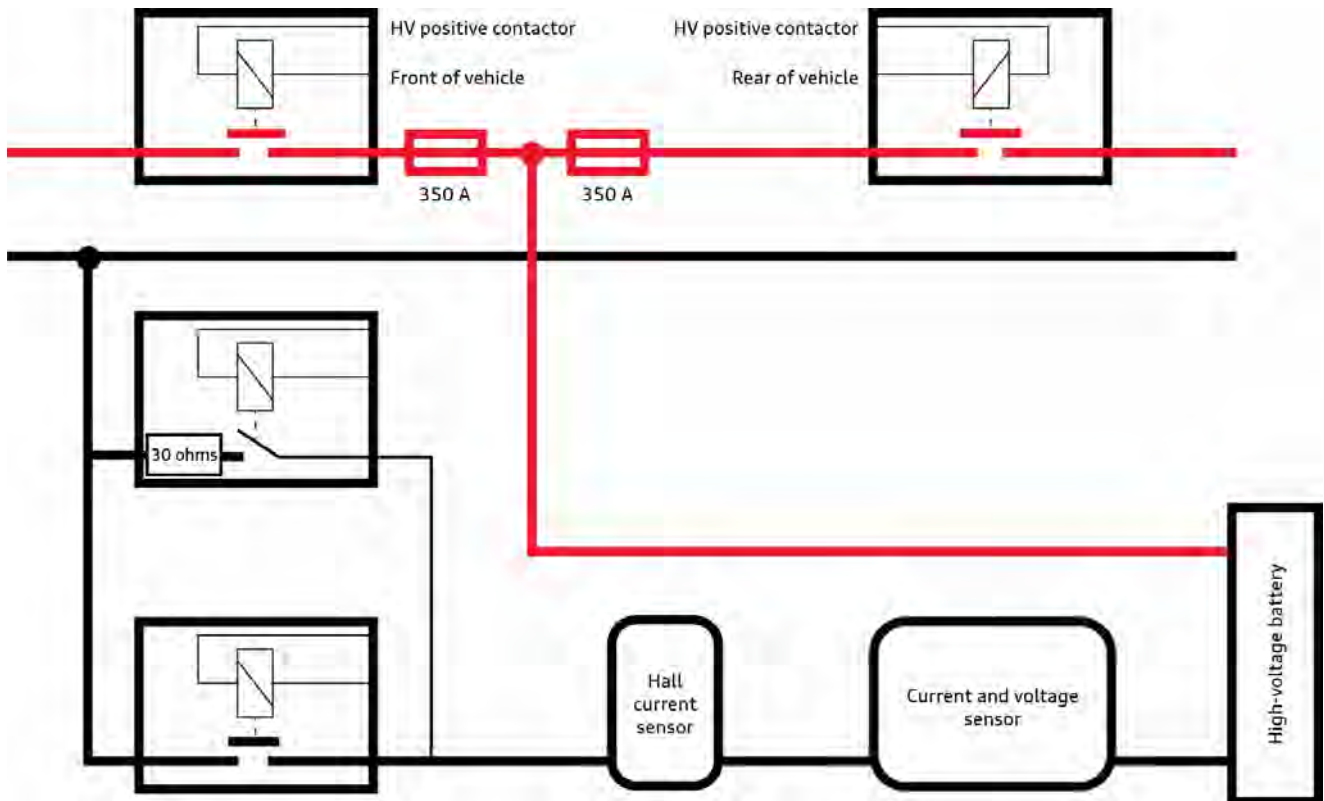

684_349

Battery regulation control unit J840

Battery regulation control unit J840 is fitted in switching unit for high-voltage battery SX6 and performs the following functions:

- > Monitoring the high-voltage battery
- > Controlling the temperature conditioning of the high-voltage battery
- > Controlling the coolant pump of the high-voltage battery
- > Event memory (storing and displaying entries)
- > Monitoring the charge level of the high-voltage battery
- > Monitoring the charge level of the cells
- > Calculating the capacity of the cells/battery
- > Calculating battery ageing
- > Insulation resistance monitoring
- > Monitoring the current
- > Switching off the high-voltage system in the event of a fault
- > Controlling the balancing function
- > Diagnosing the high-voltage battery

Cell balancing

In this example, a cell is 100% charged and the charging procedure is complete. However, the high-voltage battery charge level is only 92.5%. Balancing means that this cell is now discharged via a resistor and can thereby continue to be charged until all cells have reached the same charge level. This allows the high-voltage battery to achieve its maximum capacitance.

To do this, the battery regulation control unit J840 compares the voltages of the cell groups. If cell groups have a high cell voltage, the battery modules control unit responsible receives the balancing information. After the ignition is switched off, the battery regulation control unit J840 checks whether balancing is necessary and initiates the process as appropriate. Only the control units on the sub-CAN are active when this is done. Balancing is performed at charge levels greater than 30%.

Cell balancing takes place passively, meaning that the energy is dissipated as heat via resistors. The high-voltage battery control unit controls and monitors cell balancing. Cell balancing takes place only by discharging individual cells. Cell balancing starts every 60 minutes after the vehicle is switched off, once the difference in capacity between the cells reaches approximately 2% (120 mAh) and the charge level of the high-voltage battery is more than 30%.

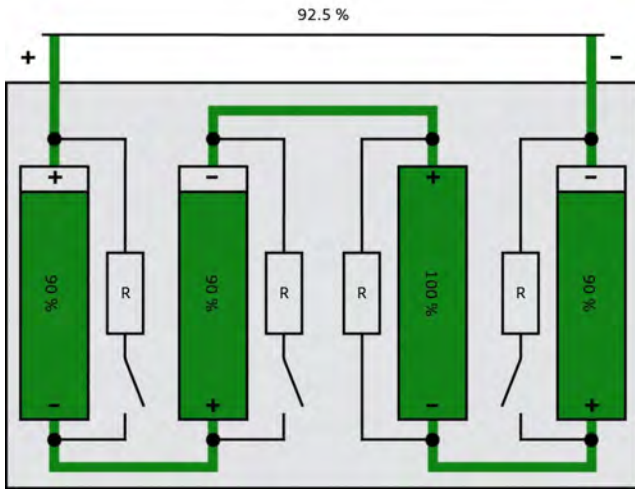

675_013

Isolation monitoring

An isolation check is carried out by switching unit for high-voltage battery SX6 when the high-voltage system is being switched on/off, during vehicle operation (every 30 seconds) and during AC/DC charging (every 30 seconds).

This involves measuring the isolation resistance between the high-voltage conductors and the housing of high-voltage battery 1 AX2 with the current battery voltage.

The system detects insufficient isolation resistances in the components and wiring of the high-voltage system. The AC connections in the high-voltage battery charging sockets and the AC/DC converter in the high-voltage battery charging units are not checked due to the electrical isolation of the charging socket to the high-voltage system. The switching unit sends the isolation value to battery regulation control unit J840 for evaluation. If a low isolation resistance is detected, the control unit sends a message to data bus diagnostic interface J533 via the hybrid CAN. Via the dash panel insert CAN, the diagnostic interface directs the control unit in dash panel insert J285 to show a message to the driver in the display in the dash panel insert. If the warning is yellow, the driver can continue driving and the drive system can be reactivated. If the isolation resistance is too low, a red warning is given. The journey can be completed, but it will not be possible to reactivate the drive system.

Power contactor with boost function J1178

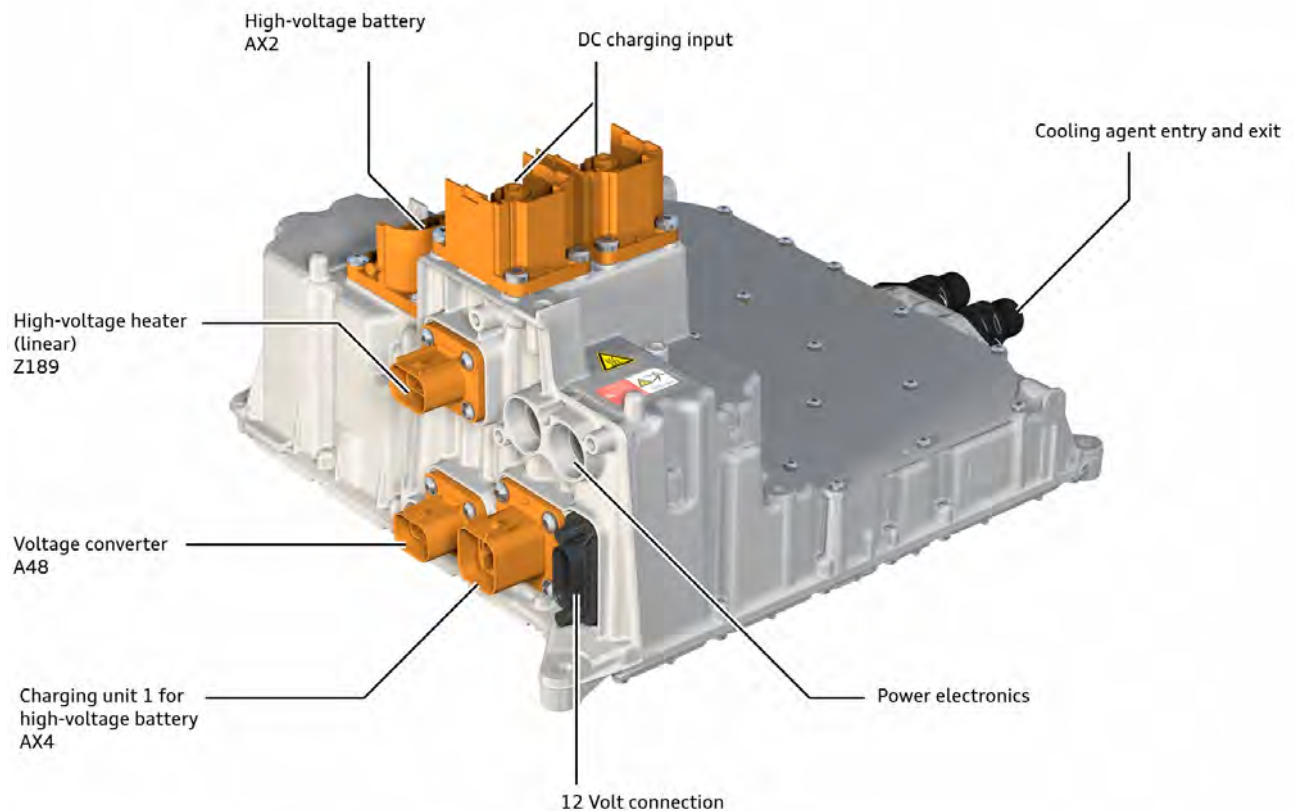

684_005

Power contactor with boost function J1178, or HV booster, acts as an energy distributor and also increases the direct-current voltage from 400 Volts to 800 Volts (hence the term “booster”). This is necessary, for example, if the vehicle is going to be charged at a public charging station with 400 Volts. Power contactor with boost function J1178 has a power output of 50 kW in the standard version, or 150 kW as optional equipment.

Several high-voltage components are connected to the HV booster; it therefore serves as an energy distributor. The components connected to the HV booster include:

- > Charging unit 1 for high-voltage battery AX4
- > High-voltage heater (linear) Z189
- > Voltage converter A48
- > High-voltage battery 1 AX2
- > Electric drive control unit for front axle J1234

Power contactor with boost function J1178 is located below voltage converter A48 and above the power electronics, centred over the vehicle’s front axle.

Voltage conversion (boost function)

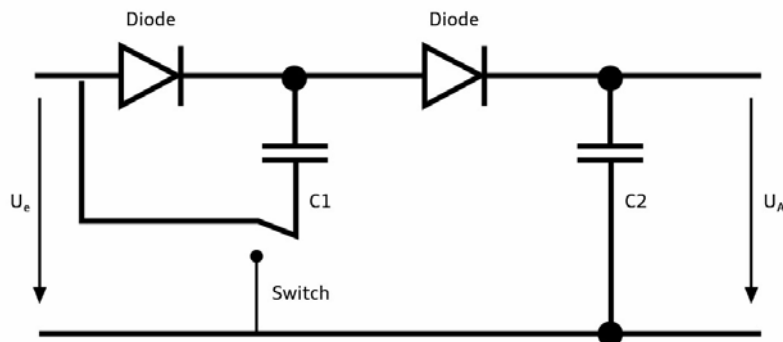

684_435

The voltage conversion (400 Volts to 800 Volts) operates on the principle of a charge pump. The basis of how it works is a series connection of the capacitor. It is important to note that the voltage converter can only double the direct-current voltage.

Power contactor with boost function J1178 acts as an energy distributor and, when necessary, as a voltage doubler if the DC charging station is able to supply a 400 Volt current.

Power contactor with boost function J1178 is designed to be maintenance-free. Opening the components is strictly prohibited.

Notes for service and diagnosis:

Location in the vehicle:	Front of vehicle
Removing and installing:	Entire component
Diagnosis capability:	Yes
Adaption/calibration function:	No
Guided Fault Finding:	Yes
Special tools:	No
Maintenance-free:	Yes
Dismantling level:	None, only complete component. Dismantling strictly prohibited!

Voltage converter A48

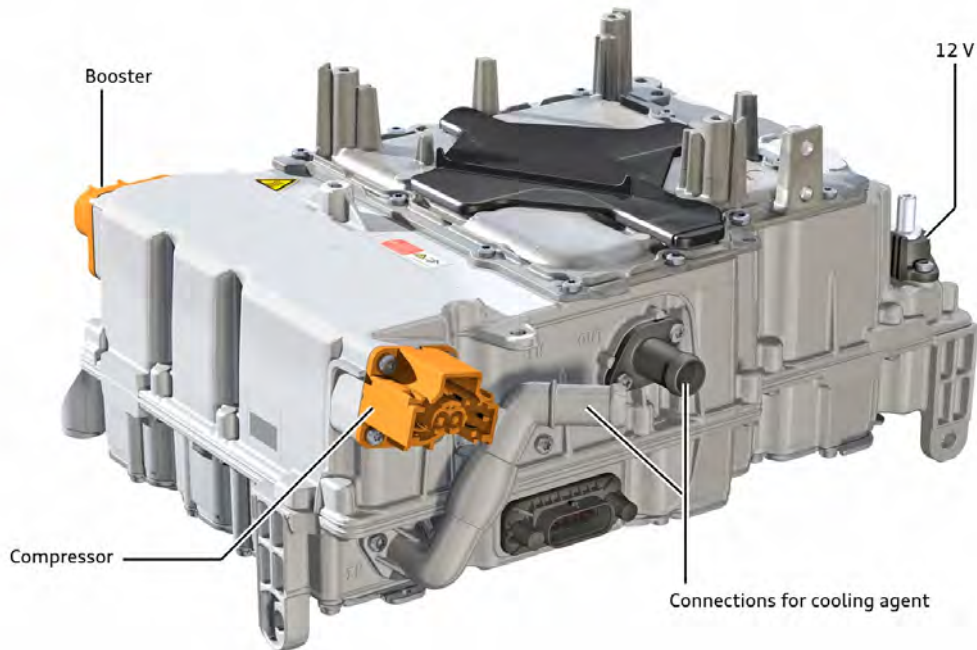

684_018

Voltage converter A48 converts the direct current of one voltage level into direct current of a different voltage level. On the Audi e-tron GT, the voltage converter is needed in order to make direct-current voltage from the high-voltage battery (approx. 800 Volts) available in the required voltage levels:

- > 400 Volts for the high-voltage air conditioner compressor
- > 12 Volts for the low-voltage electrical system

Voltage converter A48 is located over the centre of the front axle.

A voltage converter can convert the input voltage to a higher or lower voltage level; here, the voltage converter takes the input voltage from the high-voltage battery and converts it into a lower output voltage. In other words, the HV voltage converter serves as a step-down converter.

As a general rule, the HV voltage converter is set to operate as a set-down converter if:

- > The drive system is activated
- > The vehicle is being charged
- > The 12 Volt battery requires recharging

Notes for service and diagnosis

The voltage converter is maintenance-free. If defective, the entire unit must be renewed.

Diagnosis capability:	Yes
Adaption/calibration function:	No
Guided Fault Finding:	Yes
Special tools:	No
Maintenance-free:	Yes

Note on specified values for voltage converter A48

	Input voltage	Output voltage	Continuous current output	Peak current output	Power output
HV voltage converter					
800 V to 12 V	420 V ... 870 V	9 V ... 16 V	240 A	290 A	3.5 W
800 V to 400 V	420 V ... 870 V	430 V	13 A	16 A	5.3 W

Charging unit 1 for high-voltage battery AX4

When charging with alternating current, the charging voltage for the Audi e-tron GT first needs to be converted into direct-current (DC) voltage. The high-voltage battery cannot receive AC voltage. This is done using the high-voltage charger, which has a power rating of 11 kW (standard version). The number refers to the electric input power of the high-voltage charger. The high-voltage charger also contains the charging management system.

The charger is fitted centrally in the front part of the vehicle.

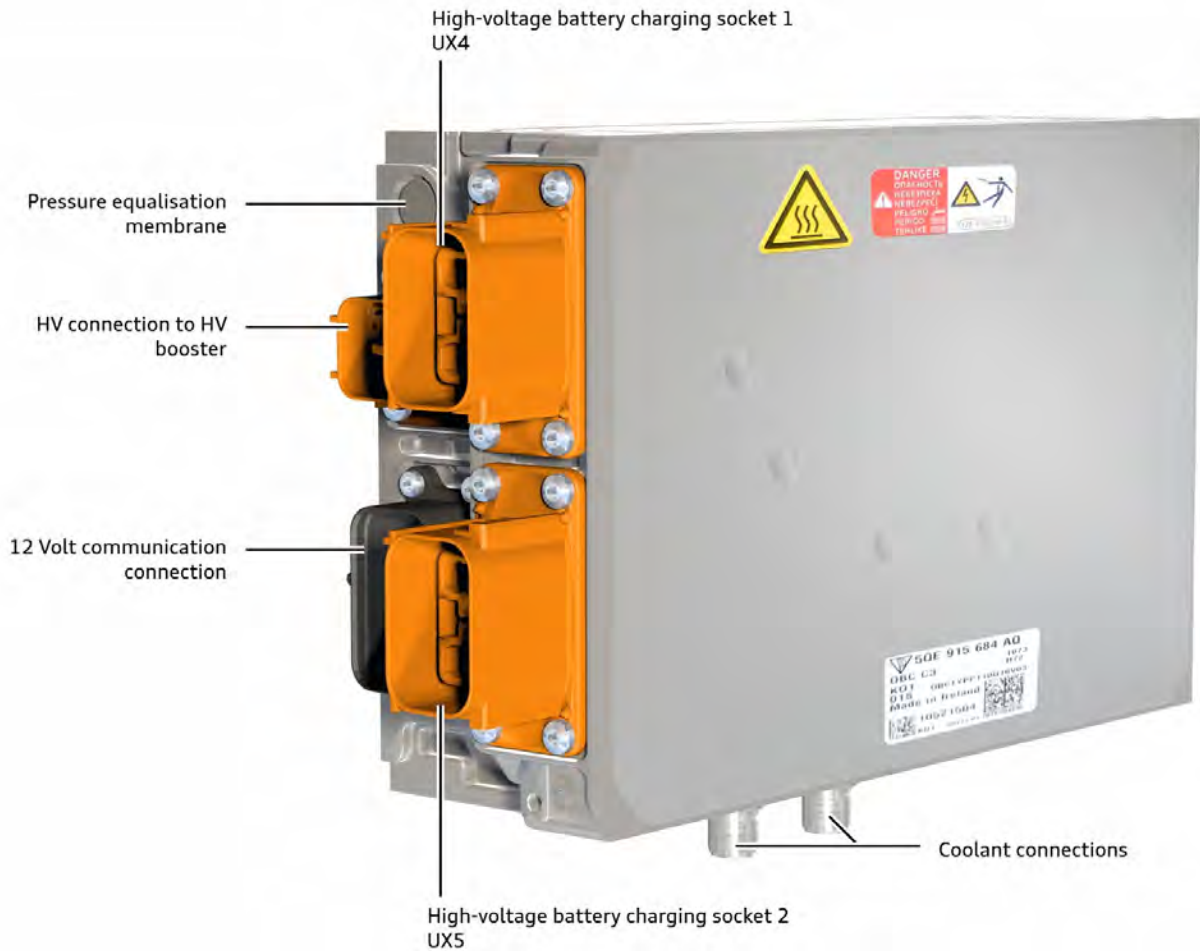

684_006

The input circuit (1) on the mains supply side contains mains filters to suppress interference from and in the mains supply (these are required by law). The rectifier bridge circuit (2) after the mains filter passively converts the alternating-current voltage (AC) from the mains supply to direct-current voltage (DC). The step-up converter (3) directly downstream from this keeps the intermediate circuit voltage in the downstream intermediate circuit capacitor (4) at a constant 400 Volts DC during the charging process in order to provide the energy for the H-bridge driver circuit (5). The H-bridge driver circuit (5) converts the direct-current voltage (400 Volts) to a square-wave alternating-current voltage (AC) with 100 kHz. This is necessary so that the energy can be transferred via the isolating transformer. The isolating transformer (6) downstream from this galvanically isolates the AC mains supply from the high-voltage electrical system of the vehicle (DC). To rectify the voltage, a full bridge rectifier (7) is positioned downstream of the output side of the isolating transformer (6). A capacitor (8) positioned after the rectifier serves to smooth and buffer the current.

Voltage path

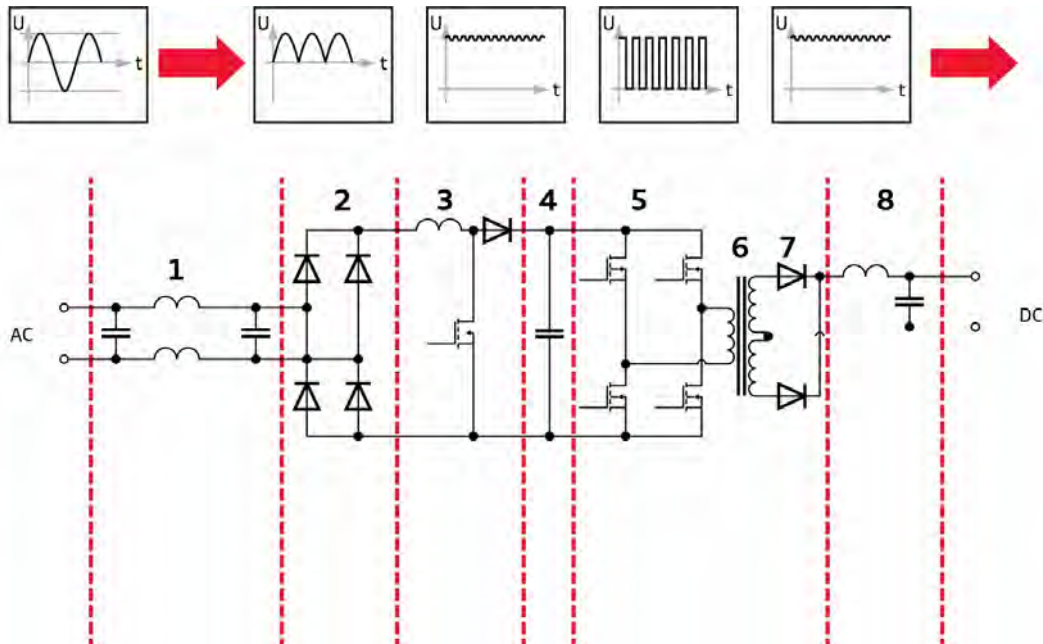

684_178

Key

- 1 AC mains input with filter
- 2 Bridge rectifier circuit
- 3 Step-up transformer
- 4 Intermediate circuit capacitor
- 5 H-bridge circuit
- 6 Isolating transformer
- 7 Full bridge rectifier
- 8 DC output with high-voltage intermediate circuit capacitor

Notes on diagnosis and maintenance

Diagnosis capability:	Yes
Adaption/calibration function:	No
Guided Fault Finding:	No
Special tools:	No
Maintenance-free:	Yes

Intermediate capacitors

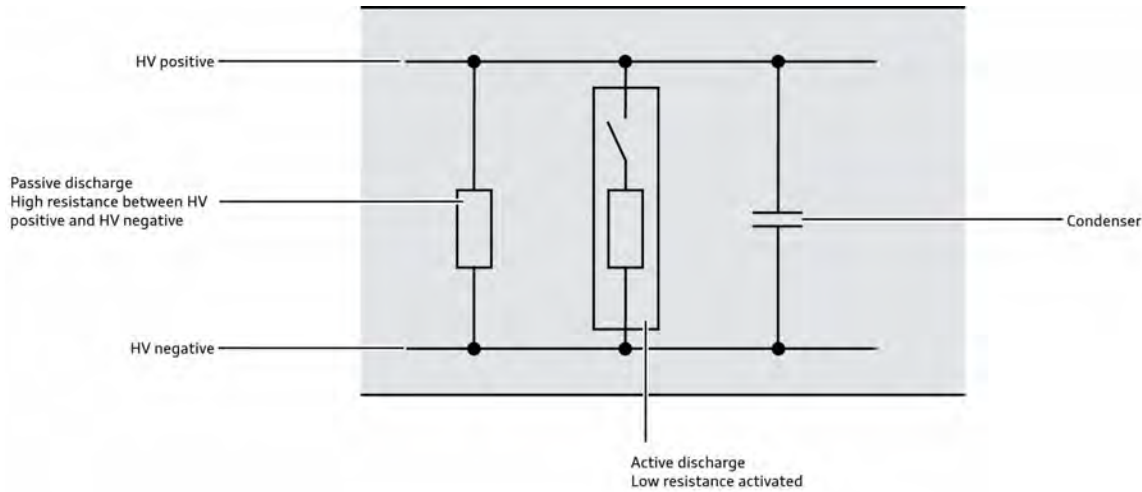

684_112

A capacitor serving as an energy store and a voltage stabiliser may be fitted between HV positive and HV negative in high-voltage components. In addition, a resistor which discharges the capacitor when the ignition is off is connected in parallel to the capacitor.

When the ignition is switched off, the capacitor on some high-voltage components is actively discharged by a switch and resistor so that the components are completely de-energised when switched off.



Note

A capacitor is fitted in some high-voltage components to store power. It must be discharged when the system is de-energised. You should therefore always de-energise the system according to the test plan in the vehicle diagnostic tester as this takes the discharging times into account. The high-voltage system must only be de-energised and worked on by qualified staff.

Additional information can be found in this SSP (refer to article “High-voltage battery 1 AX2”).

Power contactors

The power contactors open immediately if:

- > Maintenance connector TW is opened.
- > The safety computer sends a crash signal via the data bus.
- > The safety computer sends a crash signal to high-voltage battery isolation igniter via the dedicated wire.
- > The fuse for power supply to terminal 30c of the power contactors is disconnected or faulty.

Safety circuit

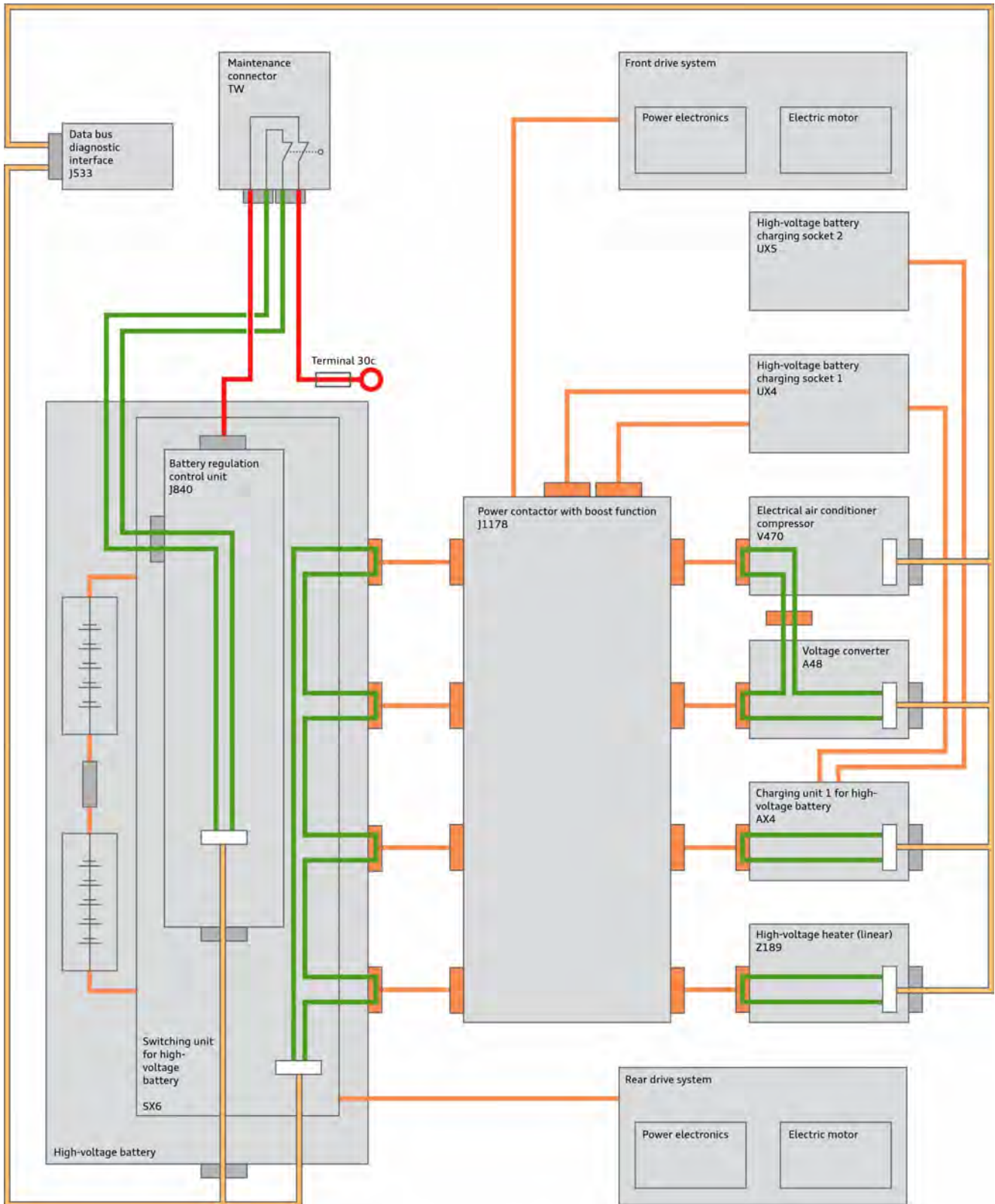

684_113

Key:

- Hybrid CAN
- High-voltage wire
- Safety circuit

- High-voltage connector
- 12 Volt connector

The vehicle has five safety circuits.

- > Safety circuit 1 passes through battery regulation control unit J840, maintenance connector TW and switching unit for high-voltage battery SX6
- > Safety circuit 2 is located within switching unit for high-voltage battery SX6
- > Safety circuit 3 is in charging unit for high-voltage battery AX4
- > Safety circuit 4 passes through voltage converter A48 and electrical air conditioner compressor
- > Safety circuit 5 is located within high-voltage heater (linear) Z189

The safety circuits in the vehicle are ring circuits that pass through the high-voltage components and control units/contact bridges in the connectors.

They are supplied with a 10 mA current from the 12 Volt electrical system.

If a safety circuit is interrupted, e.g. if a connector is unplugged, data bus diagnostic interface J533 receives a notification from the relevant control unit. A signal is sent via the dash panel insert CAN directing control unit in dash panel insert J285 to show a message to the driver. It is possible to continue driving until the ignition is switched off. It is not possible to reactivate the drive system.

Maintenance connector TW

Maintenance connector TW, also referred to as the high-voltage interlock or service disconnect, is located in the centre front of the vehicle. It is both an electrical connection in the 12 Volt control circuit for the high-voltage battery power contactors and a component part of the safety circuit. Unplugging the maintenance connector TW opens the safety circuit and breaks the 12 Volt control circuit of the power contactors. This provides a redundant safety configuration. The maintenance connector serves to de-energise the high-voltage system.

Please use the relevant program in the vehicle diagnostic tester to properly open and de-energise the high-voltage system. After being opened, maintenance connector TW is secured from being switched back on by the padlock T40262/1.

The maintenance connector is also the primary emergency cut-out connection.

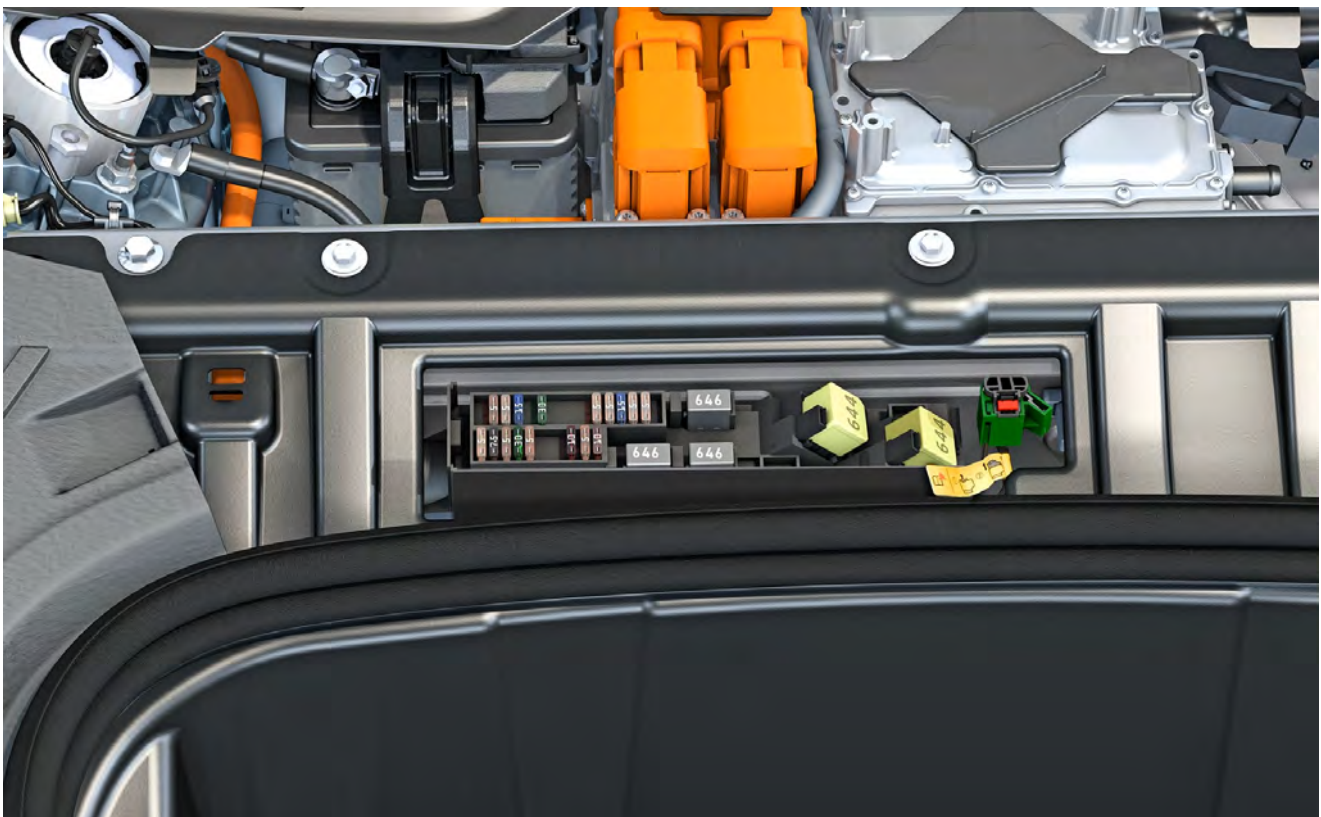

684_053

An information label is affixed to maintenance connector TW.

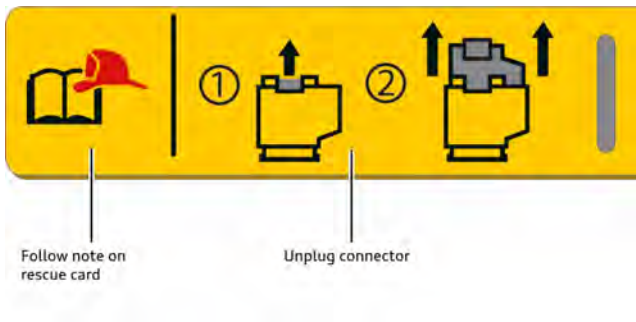

675_021

An additional emergency cut-out connection (also marked with an information label) to interrupt the control current of the power contactors is fuse no. 12, which is located in the fuse carrier behind a trim panel on the right side of the luggage compartment (no maintenance flap).

It is marked with a tag.



684_332

Charging

Charging sockets



Charging socket cover

684_011

The charging sockets for charging the high-voltage battery are located behind the charging socket covers. The charging sockets are fitted on the fender panel on the driver side and on the passenger side. Both charging sockets are fitted as standard equipment. The AC charging socket is located on the driver side; the CCS or DC charging socket (depending on the country version) is located on the passenger side.

The cover can be opened by unlocking the vehicle and pressing on the cover.

If the charging connector is plugged in, the cover cannot be closed.

If one of the two flaps is open, the other is locked. The manual release mechanism is located in the closure plate between the fender panel and the A-pillar (open the driver door/front passenger door to operate it).

Overview of the charging sockets

Combined Charging System Type 1 (CCS 1 or Combo 1) high-voltage battery charging socket 1 UX4

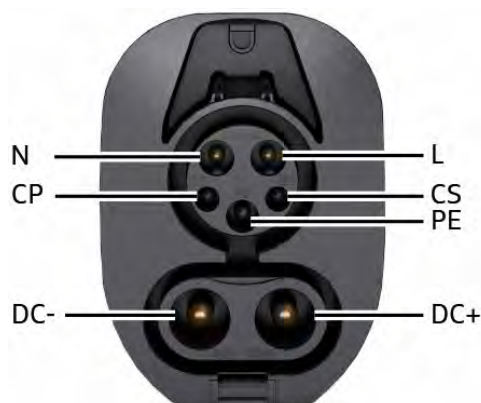

675_099

This charging socket can be used to charge the high-voltage battery with alternating current or direct current. The DC contacts are protected by a flap. Communication between the charging station and charging unit 1 for high-voltage battery AX4 takes place via contacts CP and PE.

Combined Charging System Type 2 (CCS 2 or Combo 2) high-voltage battery charging socket 1 UX4

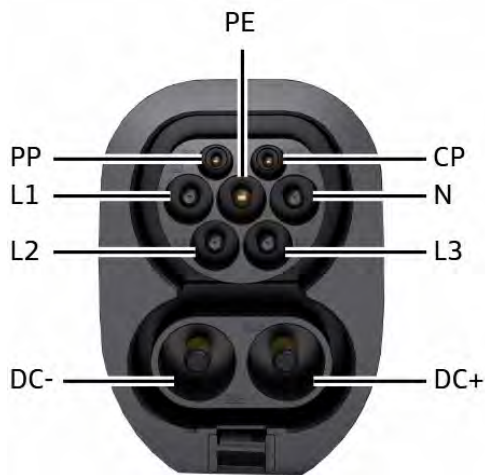

675_095

This charging socket can be used to charge the high-voltage battery with alternating current or direct current. The DC contacts are protected by a flap. Communication between the charging station and charging unit 1 for high-voltage battery AX4 takes place via contacts CP and PE.

Charge de Move (CHAdeMO) high-voltage battery charging socket 1 UX4

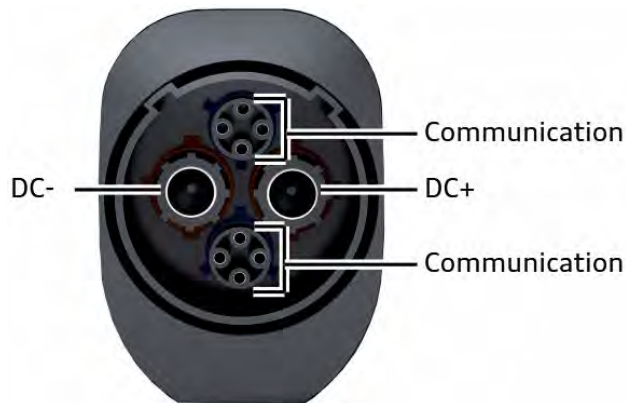

675_096

Can be used to charge the high-voltage battery with direct current (DC). Communication between the charging station and charging unit 1 for high-voltage battery AX4 takes place via the communication contacts.

China DC high-voltage battery charging socket 1 UX4

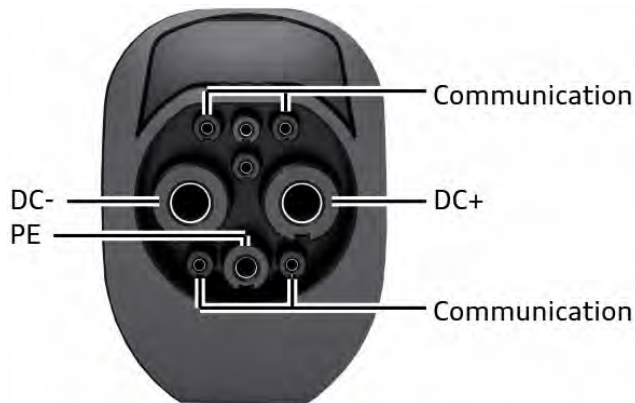

675_097

Can be used to charge the high-voltage battery with direct current (DC). Communication between the charging station and charging unit 1 for high-voltage battery AX4 takes place via the communication contacts.

Type 1 high-voltage battery charging socket 2 UX5

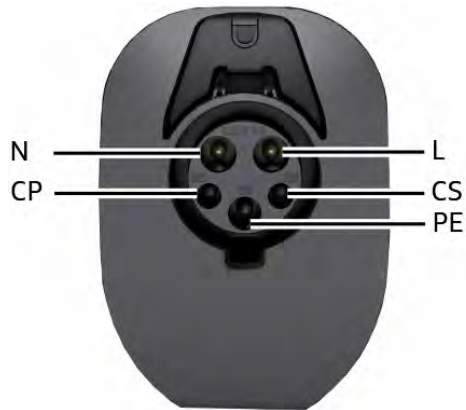

675_098

This charging socket can be used to charge the high-voltage battery with alternating current. Communication between the charging station and charging unit 1 for high-voltage battery AX4 takes place via contacts CP and PE.

Type 2 Mennekes high-voltage battery charging socket 2 UX5

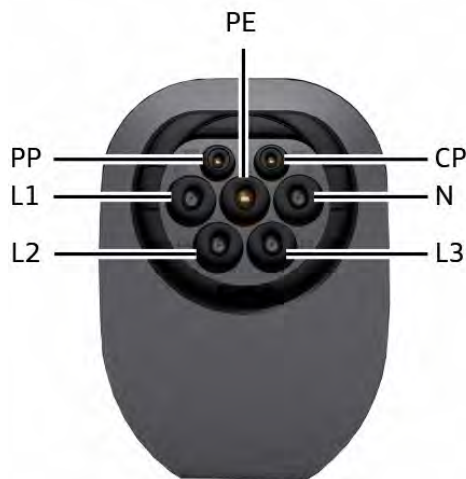

675_100

This charging socket can be used to charge the high-voltage battery with alternating current. Communication between the charging station and charging unit 1 for high-voltage battery AX4 takes place via contacts CP and PE.

China AC high-voltage battery charging socket 2 UX5

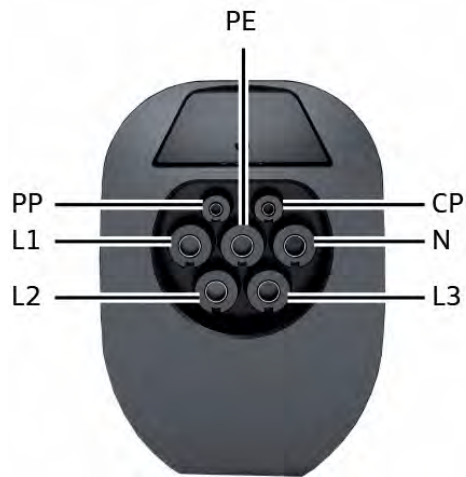

675_154

Key:

PE	Protective earth conductor
L1	Phase 1 AC
L2	Phase 2 AC
L3	Phase 3 AC
N	Neutral conductor
CP	Control pilot
PP	Proximity pilot

This charging socket can be used to charge the high-voltage battery with alternating current. Communication between the charging station and charging unit 1 for high-voltage battery AX4 takes place via contacts CP and PE.

In the case of the CHAdeMO and the China DC charging sockets, the communication with the charging station takes place via the communication contacts, and via the CP and PE contacts on all other versions.

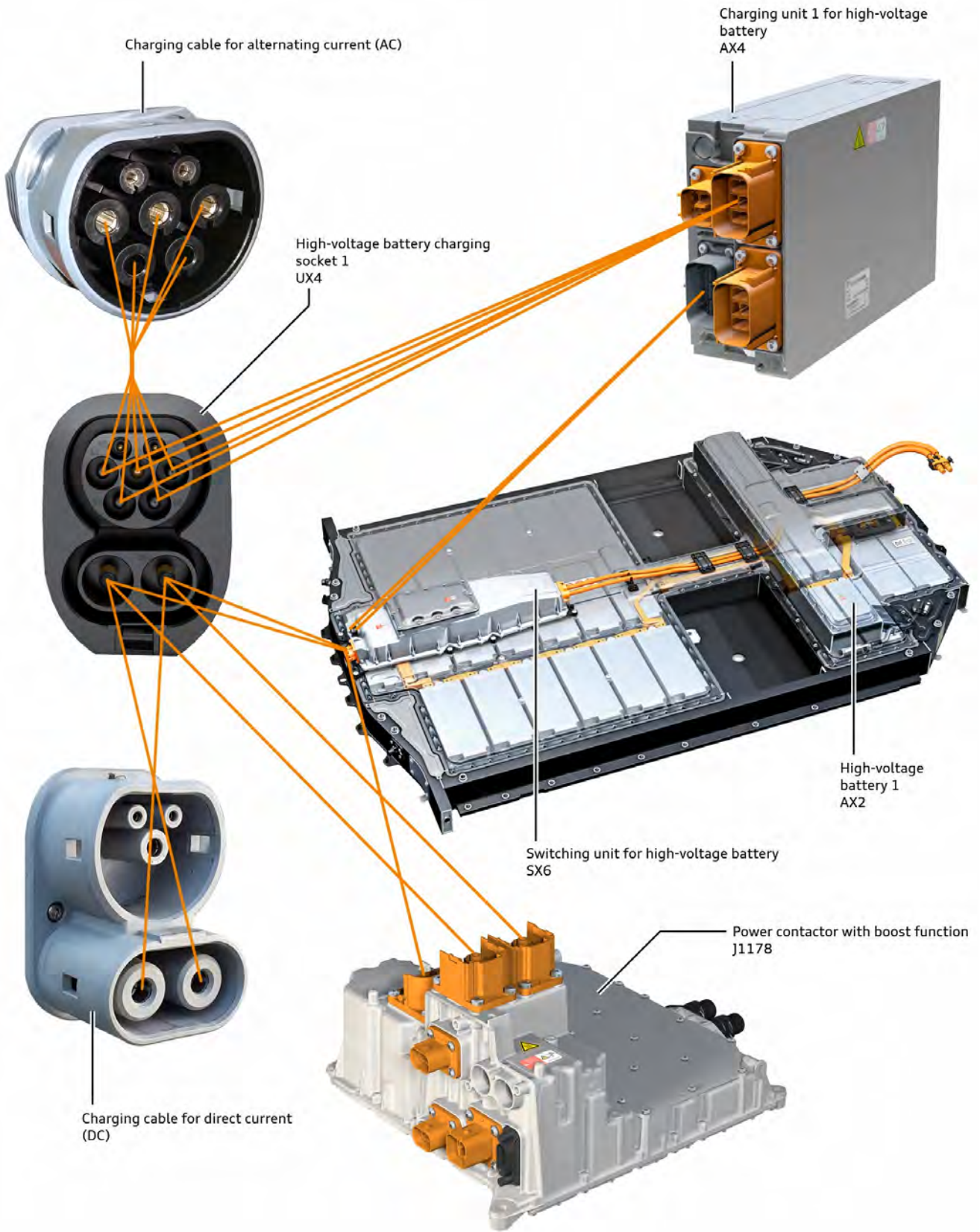

684_268

Function of the charging button

The charging button can be used to release the charging connector and end the charging cycle.

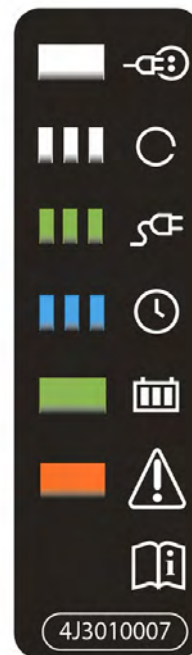

684_220

Lights and their meanings

White:	Charging cable connected
Pulsating white:	Establishing/terminating communication connection
Pulsating green:	The high-voltage battery is being charged
Green (constant):	Charging cycle completed, target charge level achieved
Flashing blue:	Waiting for charging to be started by a programmed timer
Red (constant):	Fault during charging

Charging times

Charging time for direct current (DC)	With maximum charging output for up to 100 km (WLTP)	Approx. 5 min.
Charging time for direct current (DC)	With maximum charging output (5% to ≤ 80 %)	Approx. 22.5 min.
Charging time for direct current (DC)	With maximum charging output (5% to ≤ 100 %)	Approx. 55 min.
Charging time for direct current (DC)	With 50 kW charging output (5% to ≤ 80%)	Approx. 90 min.
Charging time for direct current (DC)	With 50 kW charging output (5% to ≤ 100 %)	Approx. 125 min.
Charging time for alternating current (AC)	With 11 kW (0% to ≤ 100 %)	Approx. 9.5 h

Compact charging system

The Audi e-tron GT is supplied with the second generation Audi e-tron charging system. This is located in the motor compartment in the storage compartment. The operating unit is activated when the Audi e-tron charging system is connected to the AC power supply. The internal contactors are open in this situation so that the vehicle charging connector is not live. The contactors are only closed during charging.

A country-specific charging cable for connecting to the vehicle is permanently attached to the operating unit. One country-specific connection cable with a household plug and one with an industrial plug are also provided for connection to the AC power supply. Communication with charging unit 1 for high-voltage battery AX4 takes place via contacts CP and PE using a PWM signal.

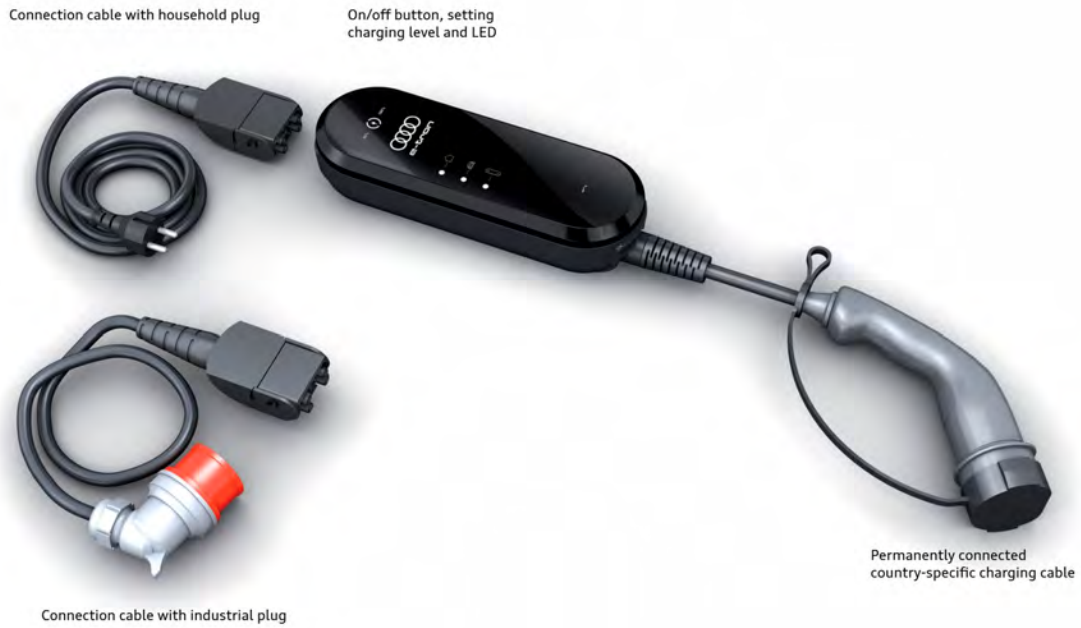

675_127

Maximum charging level if connected to AC power:

Domestic power socket	1.8 kW (8 A)
Industrial socket ^[8]	11 kW (32 A, single-phase or three-phase)

The charging level can be set to 50% or 100%. The operating units are country-specific. Please only use the Audi e-tron charging system approved for your country.

Charging clip and connector mounting

The charging clip and the connector mounting can, for example, be secured on a garage wall. The operating unit is fitted in the charging clip and locked in place. When the vehicle is not being charged, the charging cable can be wrapped around the charging clip and the vehicle charging connector can be placed in the connector mounting.

[8] The charging level is set to 50 % when the system is connected to an industrial socket. The charging level can be increased to 100%. This setting is maintained until the operating unit is disconnected from the power supply.

Connector mounting



675_128

Charging clip

Lock to secure the Audi e-tron operating unit



Charging cable can be wrapped around

675_129

Diagnosis

The operating unit uses the LEDs to indicate detected faults. Fault finding is possible using the vehicle diagnostic tester and the adapter VAS 611 009.

Air conditioning and thermal management

Climate control

The Audi e-tron GT (type F8) has a 3-zone air conditioner with an air ionisation system. The occupants can use operating and display unit for front air conditioning system E87 and operating and display unit for rear air conditioning system E265 to inform heater and air conditioning system control unit J979 of their air conditioning requirements. The separately fitted heater and air conditioning system control unit J979 is the core element of the climate control in the Audi e-tron GT (type F8). Control unit J979 uses various sensors to detect the current status in the vehicle interior and can meet the air conditioning requirements of the occupants by activating the individual air and temperature flaps as necessary.

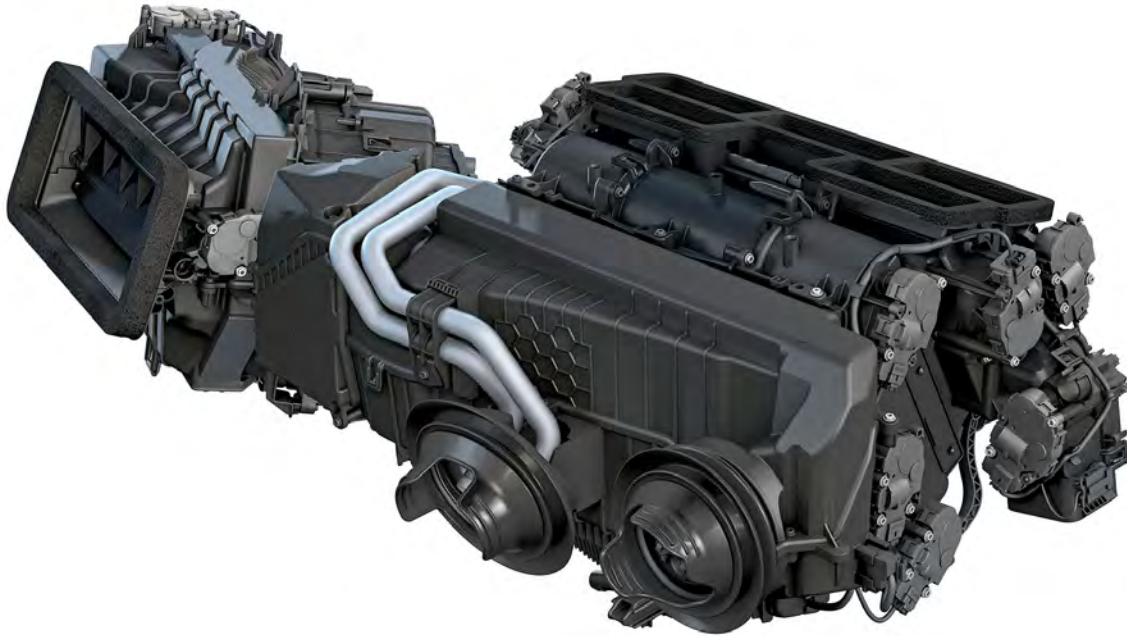

684_185

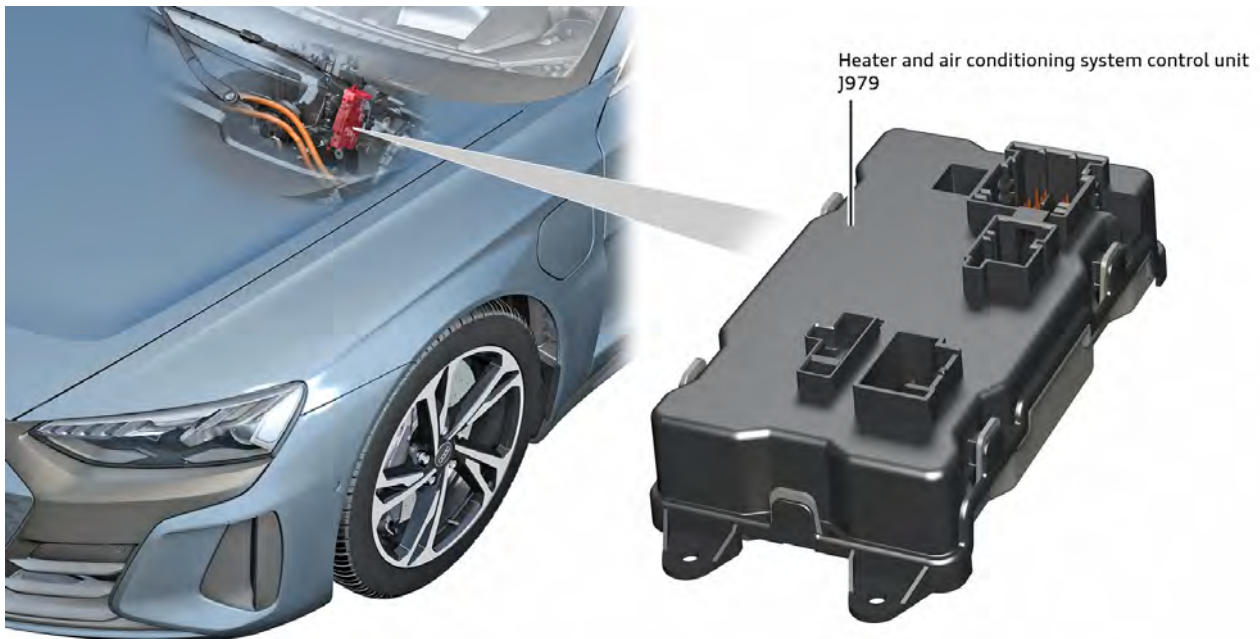

684_183



Note

Further information can be found in the current flow diagram for the vehicle.

Operating and display unit for front air conditioning system
E87



684_088

Operating and display unit for rear air conditioning system
E265



684_089



Note

Further information on operating the air conditioner (e.g. auxiliary air conditioner) can be found in the vehicle's Owner's Manual.

Air ionisation system

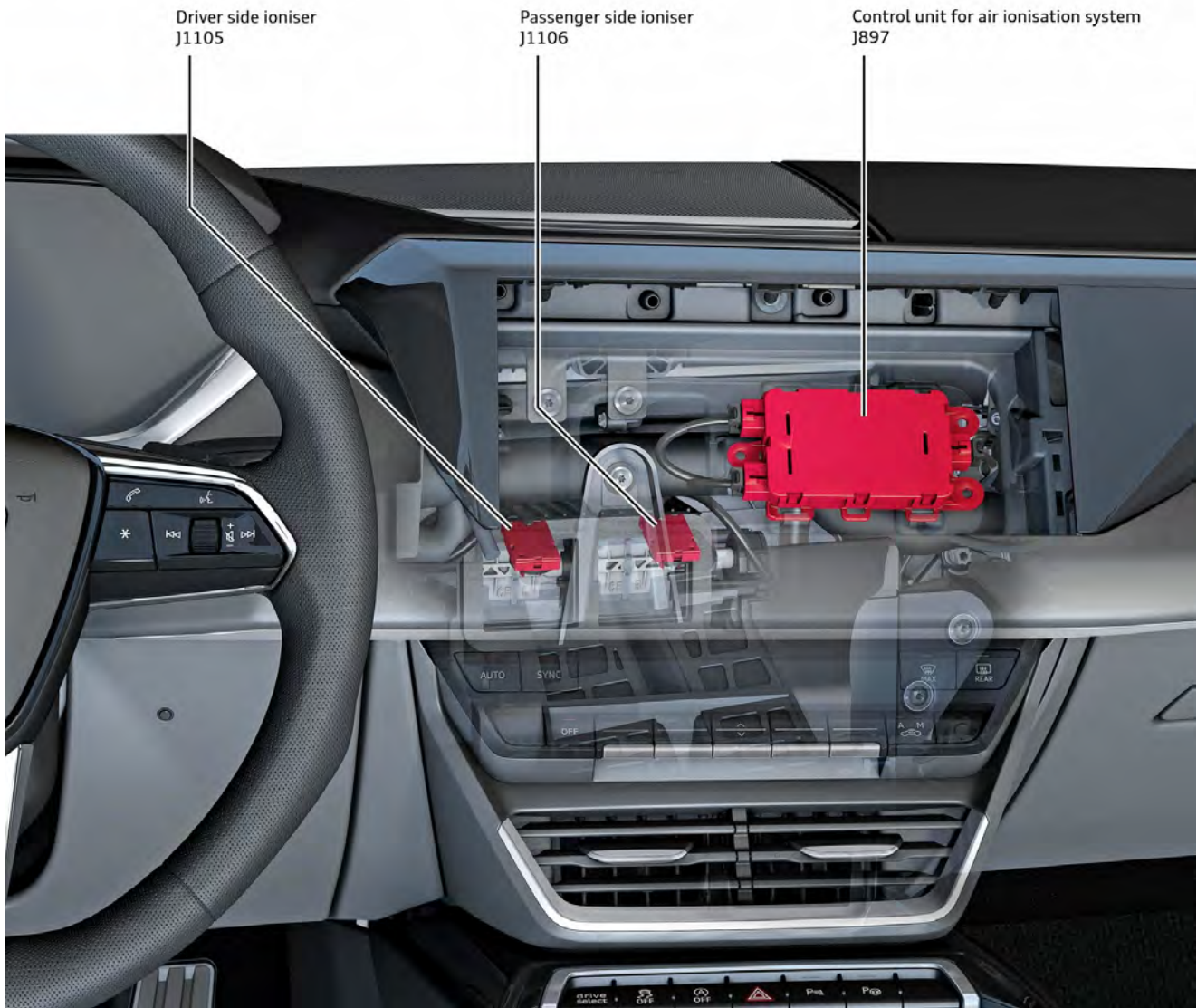

684_264

Ionisers

The task of the ioniser (emitter) is to improve the air in the vehicle interior. More precisely, it reduces pollution in the air from, for example, dust, pollen and spores which were not filtered by the dust and pollen filter. An increased ion concentration can also help increase occupant comfort.

To do this, ioniser control unit J897 and the two ionisers (driver side ioniser J1105 and passenger side ioniser J1106), which actually freshen the air, are required. Ionised air is available from the front centre vents.

Ionisation can be enabled and disabled in the MMI.



Reference

Further information on the air ionisation system can be found in self-study programme 665 (refer to article “Air improvement system”).

Thermal management control unit J1024

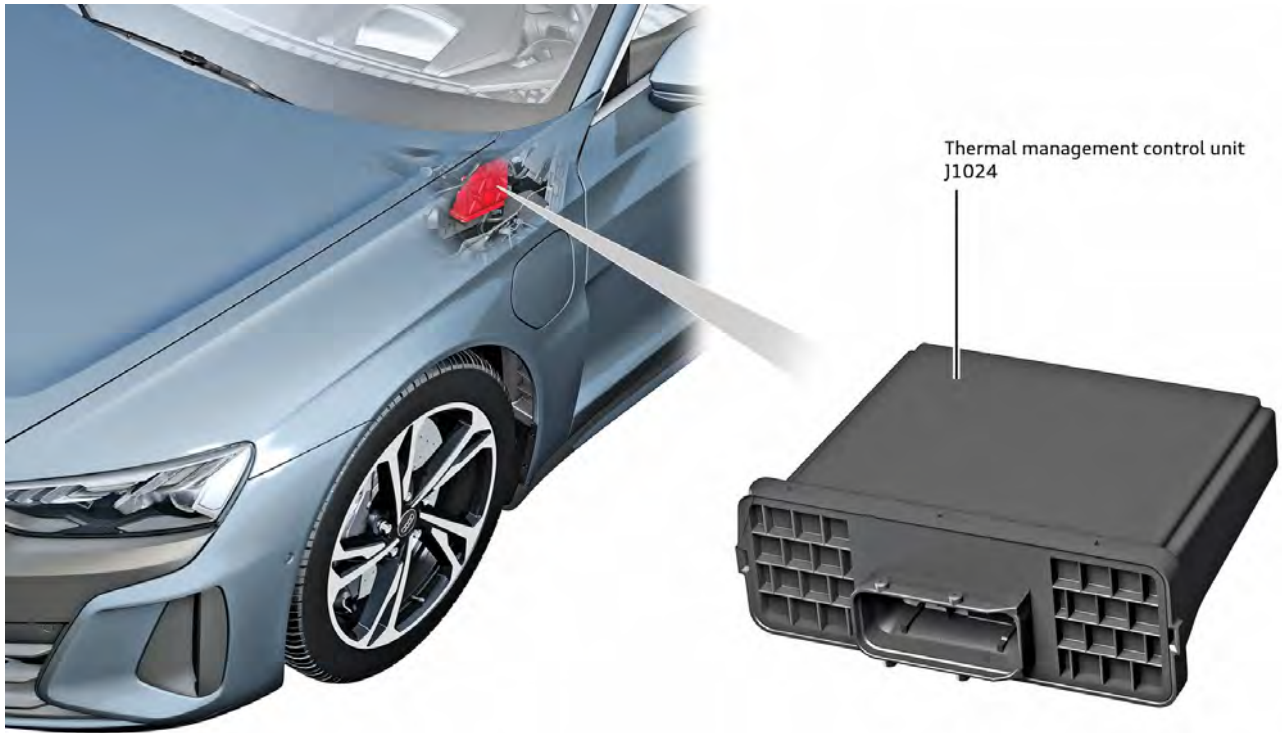

684_265

The heart of the thermal management of the Audi e-tron GT (type F8) is thermal management control unit J1024. Its main task is to use the thermal energy present or required as efficiently as possible or to make it available. This task can be achieved by effectively regulating and controlling the refrigerant and coolant circuits and using the heat pump function. The coolant circuits comprise the heating circuit, which is required to heat the vehicle interior, the coolant circuit for the high-voltage battery, which is used to heat or cool the corresponding components, and the coolant circuit for the electric powertrain which regulates the temperature of the connected components.

Thermal management control unit J1024 decides whether the coolant circuits should operate independently or in combination on the basis of the input information and the requests from individual components. There are a large number (approx. 300) of switches to use the coolant circuits efficiently and effectively.

The thermal management control unit J1024 is integrated in the vehicle's network via the hybrid CAN, which it uses to exchange information with other control units and systems.



Note

Further information can be found in the current flow diagram for the vehicle.

Electrical air conditioner compressor V470

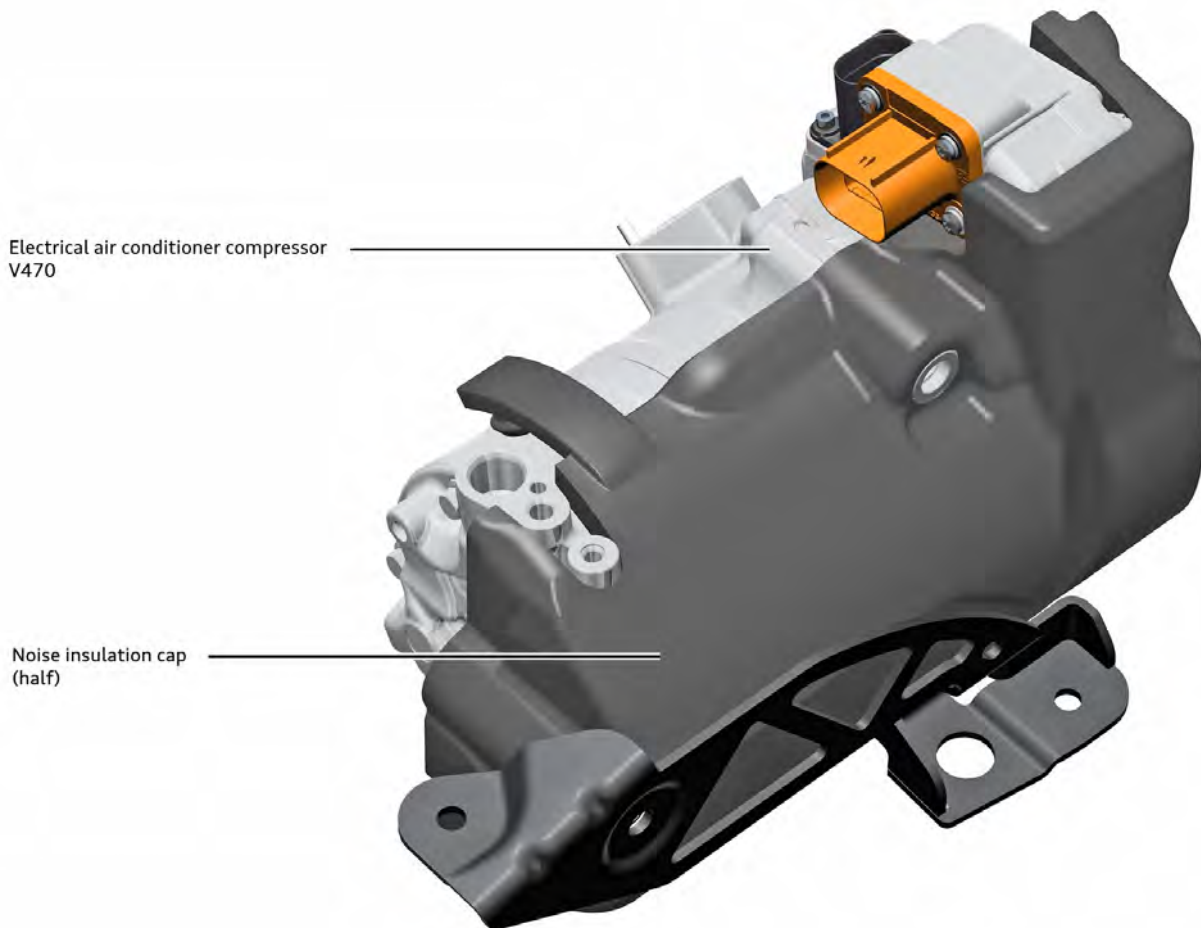

684_007

Electrical air conditioner compressor V470 fitted on the Audi e-tron GT works on the scroll compressor principle. This type of air conditioner compressor has already been used on other electric Audi models.

Control unit for air conditioner compressor J842 is integrated in the electrical air conditioner compressor and communicates with thermal management control unit J1024 via LIN bus. There is also an intermediate circuit capacitor in the air conditioner compressor V470, which is discharged passively.

To improve the acoustics, electrical air conditioner compressor V470 is also equipped with a noise insulation cap.

Technical data

Voltage	400 Volt DC
Speed	700 - 8500 rpm
Power	3.9 kW

High-voltage heater (linear) Z189

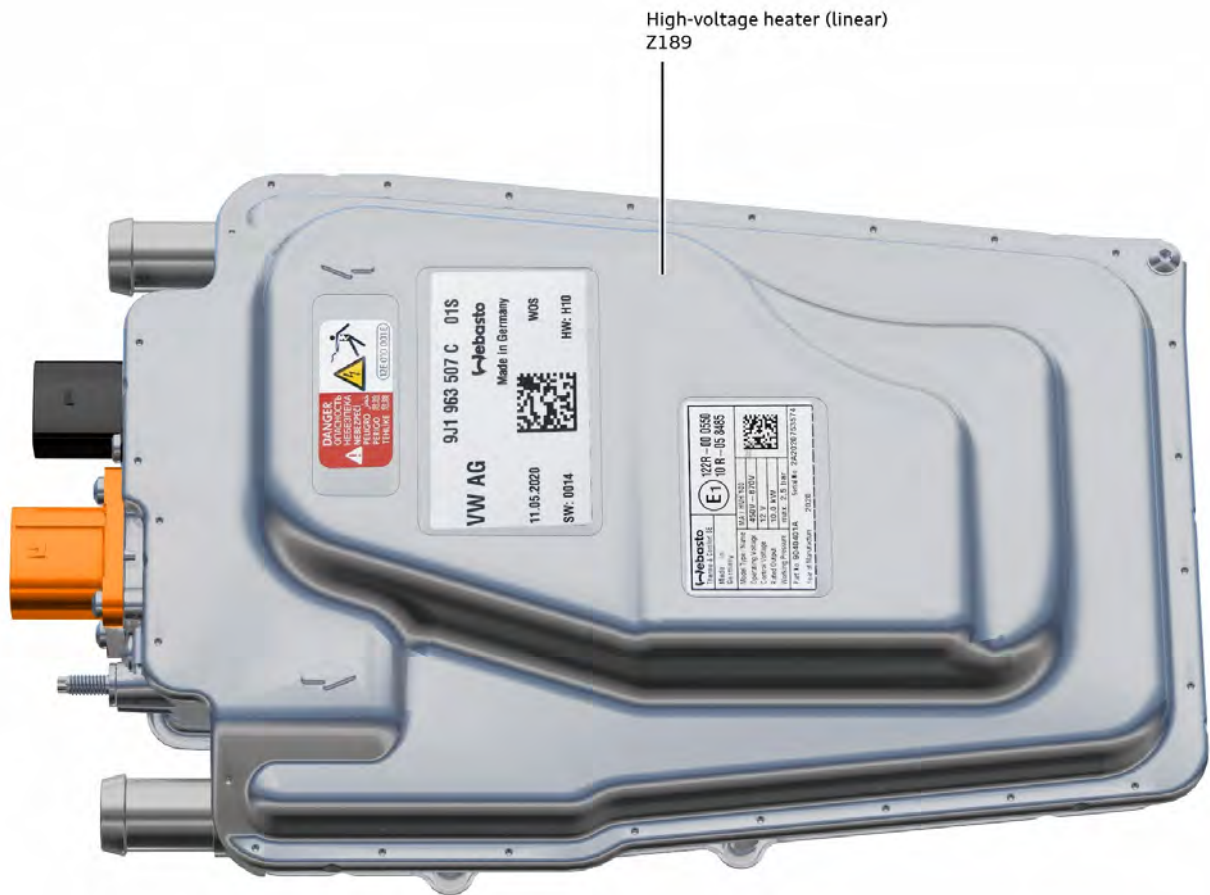

684_008

High-voltage heater (linear) Z189 is a thermal management component. Its task is to heat the coolant in the coolant circuit as necessary when requested.

A flat, electrically isolated heating element is applied to a metal plate inside high-voltage heater Z189. If current is now applied to the heating element, it heats the metal plate. This then transmits the heat to the coolant, which is guided past on the other side of the plate.

The nominal voltage of the high-voltage heater Z189 is 800 V. However, it is capable of providing approx. 3.5 kW of heating output from an input voltage of approx. 250 V. The maximum heating output of approx. 10 kW is available from a voltage of 450 V.

The control unit integrated in the high-voltage heater (linear) Z189 is a LIN bus node and exchanges information with thermal management control unit J1024 via the LIN bus.



Note

When the auxiliary air conditioning is active, the high-voltage system is active and the high-voltage components are energised. The timer settings for charging and air conditioning are stored in the control unit for high-voltage battery charging unit J1050.

Refrigerant circuit for climate control in vehicle interior

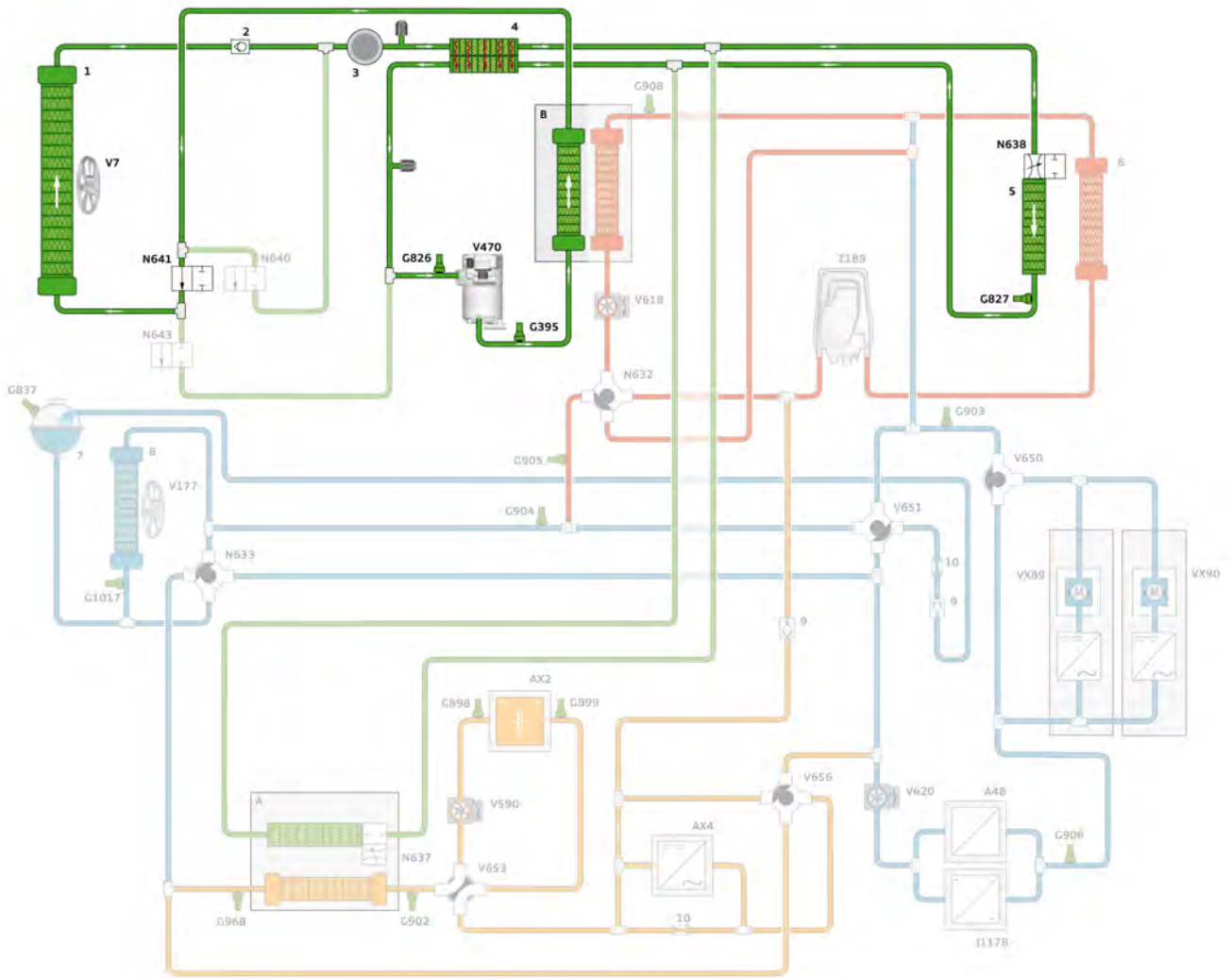

684_024

In the refrigerant circuit for climate control in the vehicle interior, electrical air conditioner compressor **V470** transports the compressed gaseous refrigerant through heat condenser **B** and refrigerant shut-off valve **N641** to the condenser **1**. The gaseous refrigerant is cooled and liquefied in the condenser. The liquid refrigerant flows through the non-return valve in the refrigerant circuit **2**, the dryer **3** and the internal heat exchanger **4** to refrigerant expansion valve **N638**. The refrigerant is atomised and vaporised by refrigerant expansion valve **3**. In this process, heat and moisture is removed from the air passing through the evaporator **5** on the way to the vehicle interior. The gaseous refrigerant flows through the internal heat exchanger **4** back to electrical air conditioner compressor **V470**.

Heat pump function

With residual heat from high-voltage battery 1 AX2

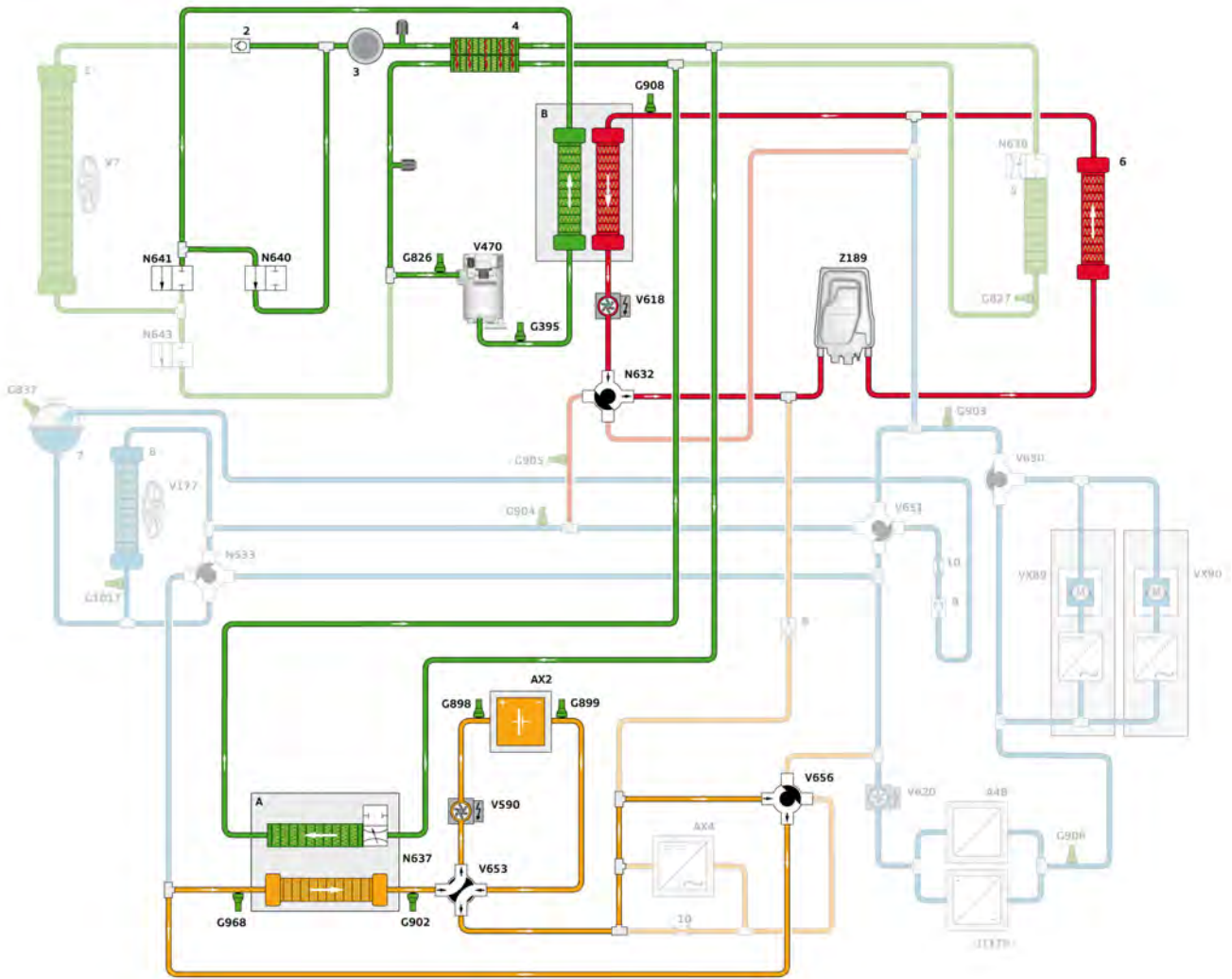

684_026

The residual heat from high-voltage battery 1 AX2 can be used to heat the vehicle interior via the heat pump function.

The gaseous refrigerant heated up in heat exchanger for high-voltage battery A is drawn in and compressed in the internal heat exchanger 4 by the electrical air conditioner compressor V470. This heats the refrigerant further. In the heat condenser B, the hot, gaseous refrigerant passes the heat energy to the coolant in the heating circuit. In this process, the refrigerant cools and liquefies again. It flows through the opened refrigerant shut-off valve 2 N640, the dryer 3 and the internal heat exchanger 4 to refrigerant expansion valve 2 N637. The refrigerant is atomised and vaporised with the help of the expansion valve N637.

The closed refrigerant shut-off valve 3 N641 and the non-return valve in the refrigerant circuit 2 prevent refrigerant from entering the condenser 1.

Heating circuit

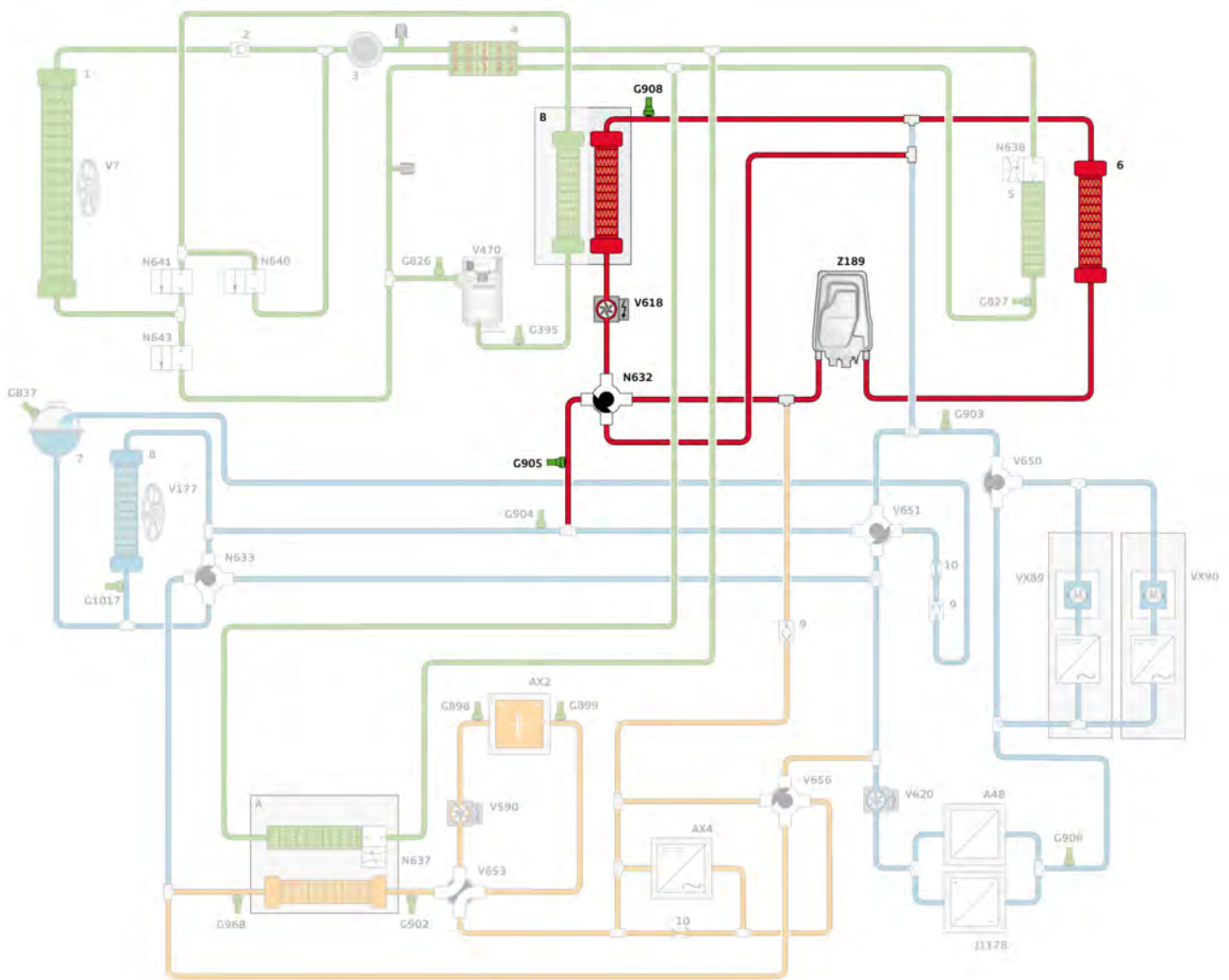

684_028

The heating circuit consists of the following components:

Thermal management coolant pump 2 **V618**, coolant changeover valve 1 **N632**, high-voltage heater (linear) **Z189**, heat exchanger for interior heating **6**, coolant temperature sender 7 for thermal management **G908**, heat condenser **B**, coolant temperature sender 4 for thermal management **G905**.

Coolant circuit for high-voltage battery

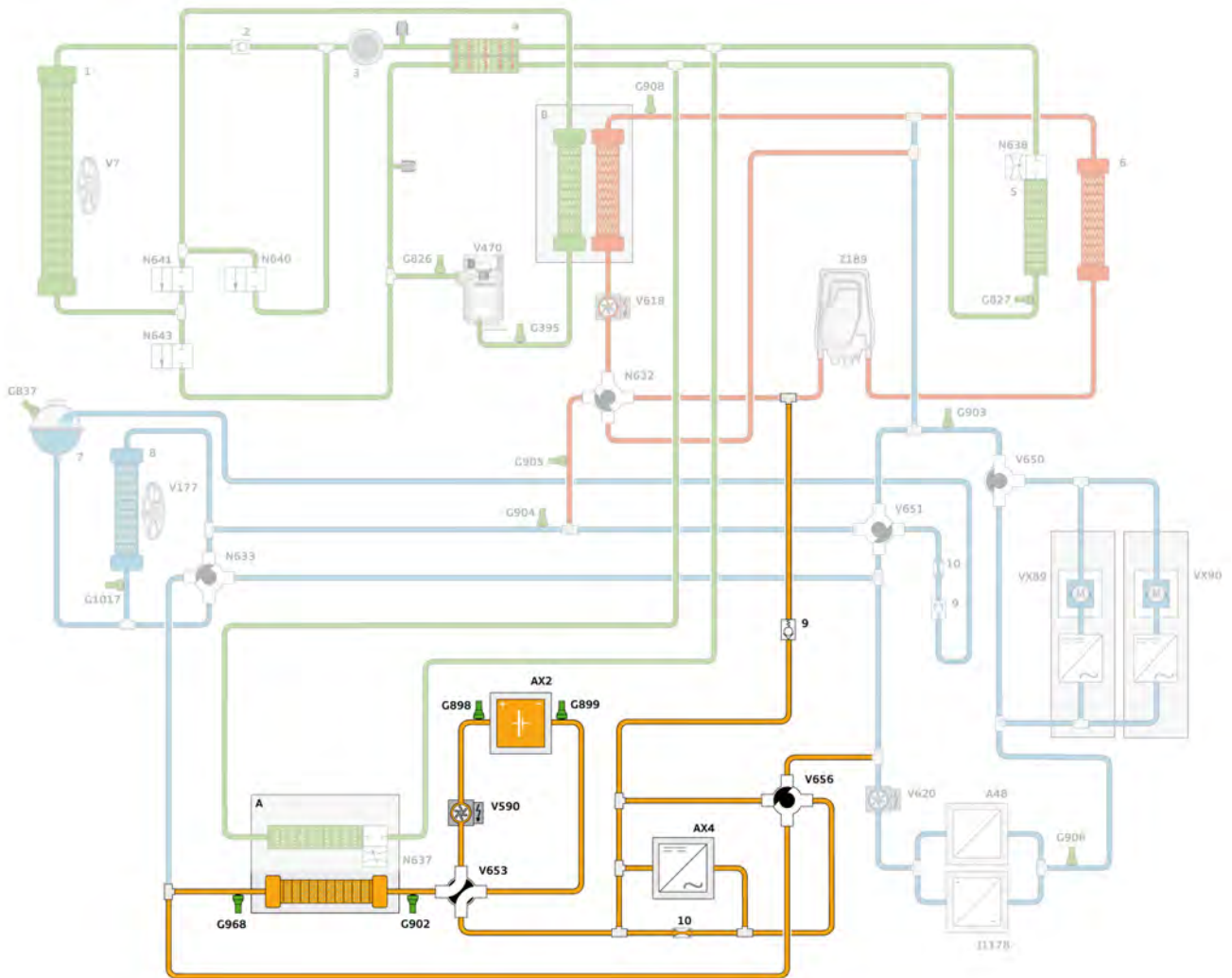

684_030

The coolant circuit for high-voltage battery incorporates the following components:

Coolant pump for high-voltage battery **V590**, coolant temperature sender 1 for high-voltage battery **G898**, high-voltage battery 1 **AX2**, coolant temperature sender 2 for high-voltage battery **G899**, changeover and mixing valve 4 for thermal management **V653**, charging unit 1 for high-voltage battery **AX4**, restrictor **10**, changeover and mixing valve 7 for thermal management **V656**, coolant temperature sender 8 for thermal management **G968**, heat exchanger for high-voltage battery (chiller) **A**, coolant temperature sender 1 for thermal management **G902** and a non-return valve **9**.

Temperatures of approx. 30 °C may occur during operation.

Example: Actively cooling high-voltage battery 1 AX2

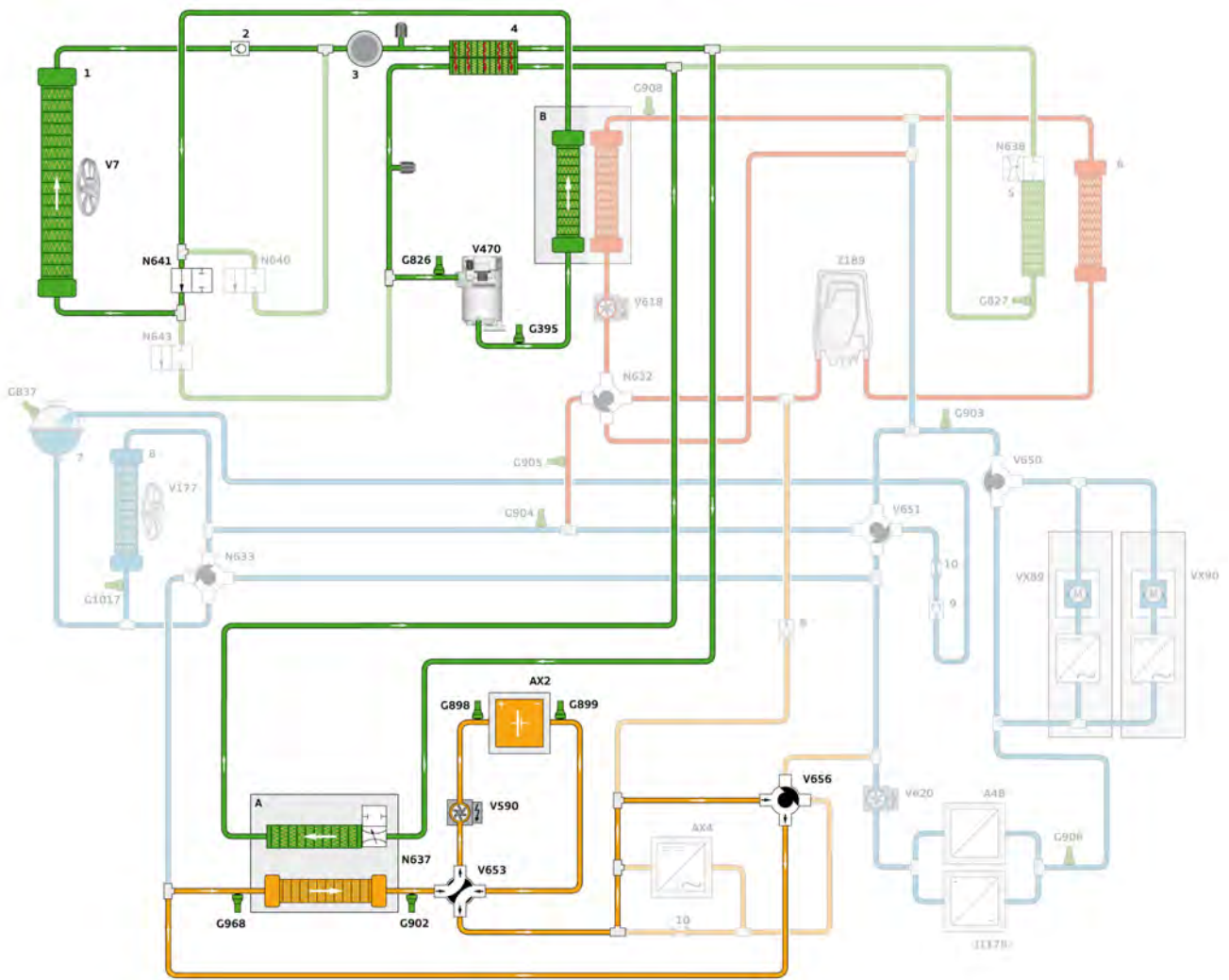

684_032

Coolant pump for high-voltage battery **V590** transports the coolant through high-voltage battery 1 **AX2**, changeover and mixing valve **4** for thermal management **V653**, changeover and mixing valve **7** for thermal management **V656**, the heat exchanger for high-voltage battery **A** and changeover and mixing valve **4** for thermal management **V653**.

The activated refrigerant circuit for cooling high-voltage battery 1 **AX2** branches off after the internal heat exchanger **4** towards refrigerant expansion valve **2 N637** and heat exchanger for high-voltage battery **A**. As it vaporises, the refrigerant absorbs the heat from the coolant circuit for the high-voltage battery in the heat exchanger for high-voltage battery. From there, the refrigerant flows on and back into the refrigerant circuit for climate control in the vehicle interior before the internal heat exchanger where it can release its heat energy into the atmosphere in the condenser **1**.

Example: Heating high-voltage battery 1 AX2

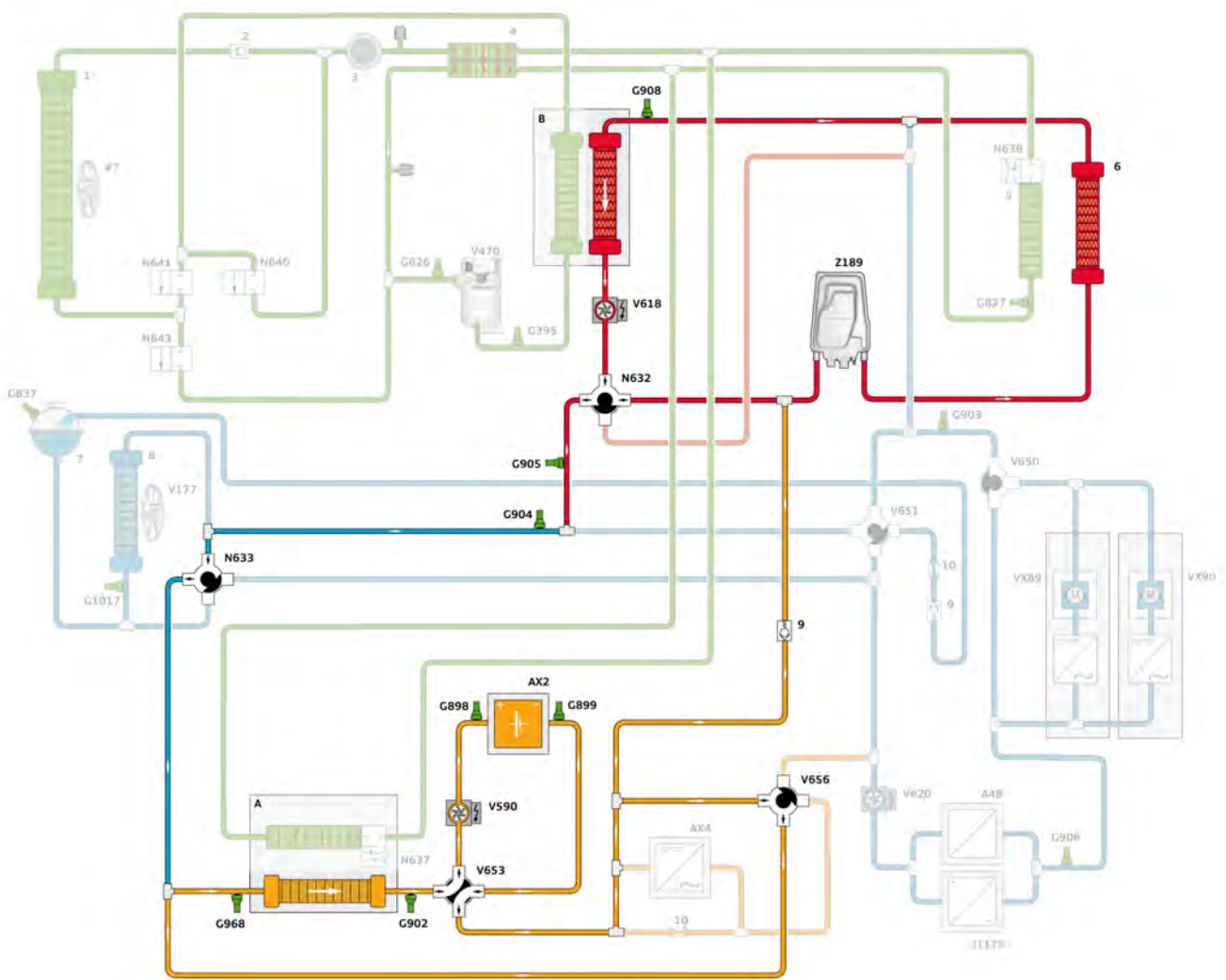

684_033

Coolant pump for high-voltage battery **V590** transports the coolant through high-voltage battery 1 **AX2**, changeover and mixing valve 4 for thermal management **V653**, changeover and mixing valve 7 for thermal management **V656**, the heat exchanger for high-voltage battery **A** and changeover and mixing valve 4 for thermal management **V653** before returning to coolant pump **V590**.

A regulated portion of the coolant flow can be transported into the heating circuit downstream of changeover and mixing valve 4 for thermal management **V653** and the non-return valve **9**. It flows into high-voltage heater (linear) **Z189** and is heated there. The coolant then passes through the heat exchanger for interior heating **6** and the heat condenser **B**. Thermal management coolant pump **V618** pumps the coolant through coolant changeover valve **1 N632** into the coolant circuit for electric powertrain. The heated coolant flows back into the coolant circuit for the high-voltage battery via coolant changeover valve **2 N633**.

Coolant circuit for electric powertrain

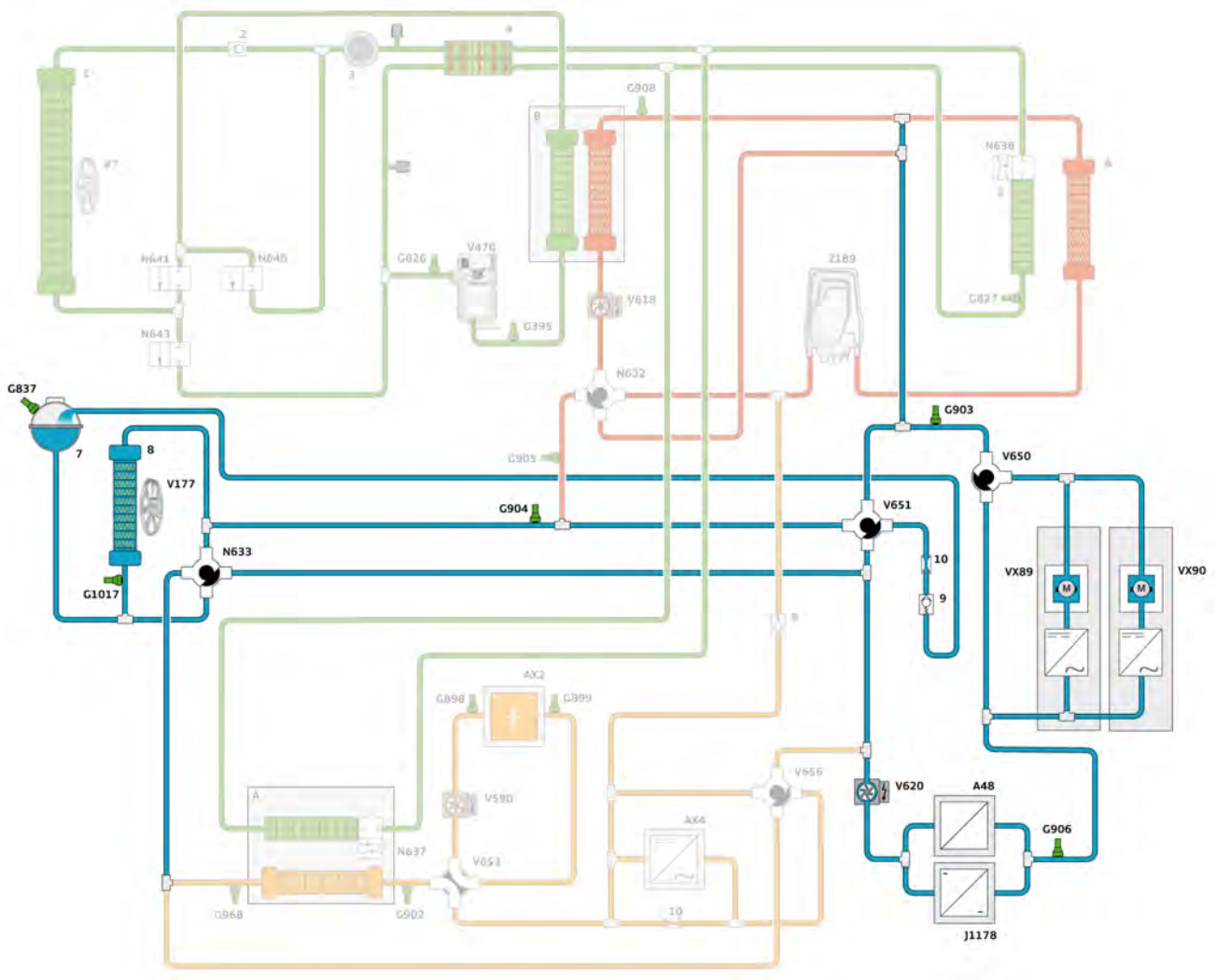

684_034

The following components are incorporated in the coolant circuit for the electric powertrain:

Thermal management coolant pump 4 **V620**, voltage converter for 800 V, 400 V, 48 V, 12 V **A48**, power contactor with boost function **J1178**, coolant temperature sender 5 for thermal management **G906**, three-phase current drives **VX89** and **VX90**, changeover and mixing valve for thermal management **V650**, coolant temperature sender 2 for thermal management **G903**, changeover and mixing valve 2 for thermal management **V651**, coolant temperature sender 3 for thermal management **G904**, low-temperature radiator **8**, coolant temperature sender 9 for thermal management **G1017**, coolant changeover valve 2 **N633**. The restrictor **10**, non-return valve **9**, coolant expansion tank 2 (for high-voltage system) **7** and coolant shortage indicator sender 2 **G837** are also part of the coolant circuit for the electric powertrain.

Temperatures of up to 65 °C can occur in the coolant circuit for the electric powertrain.

Cooling high-voltage battery 1 AX2 when charging

Example: Charging high-voltage battery with alternating current (AC) while cooling is active

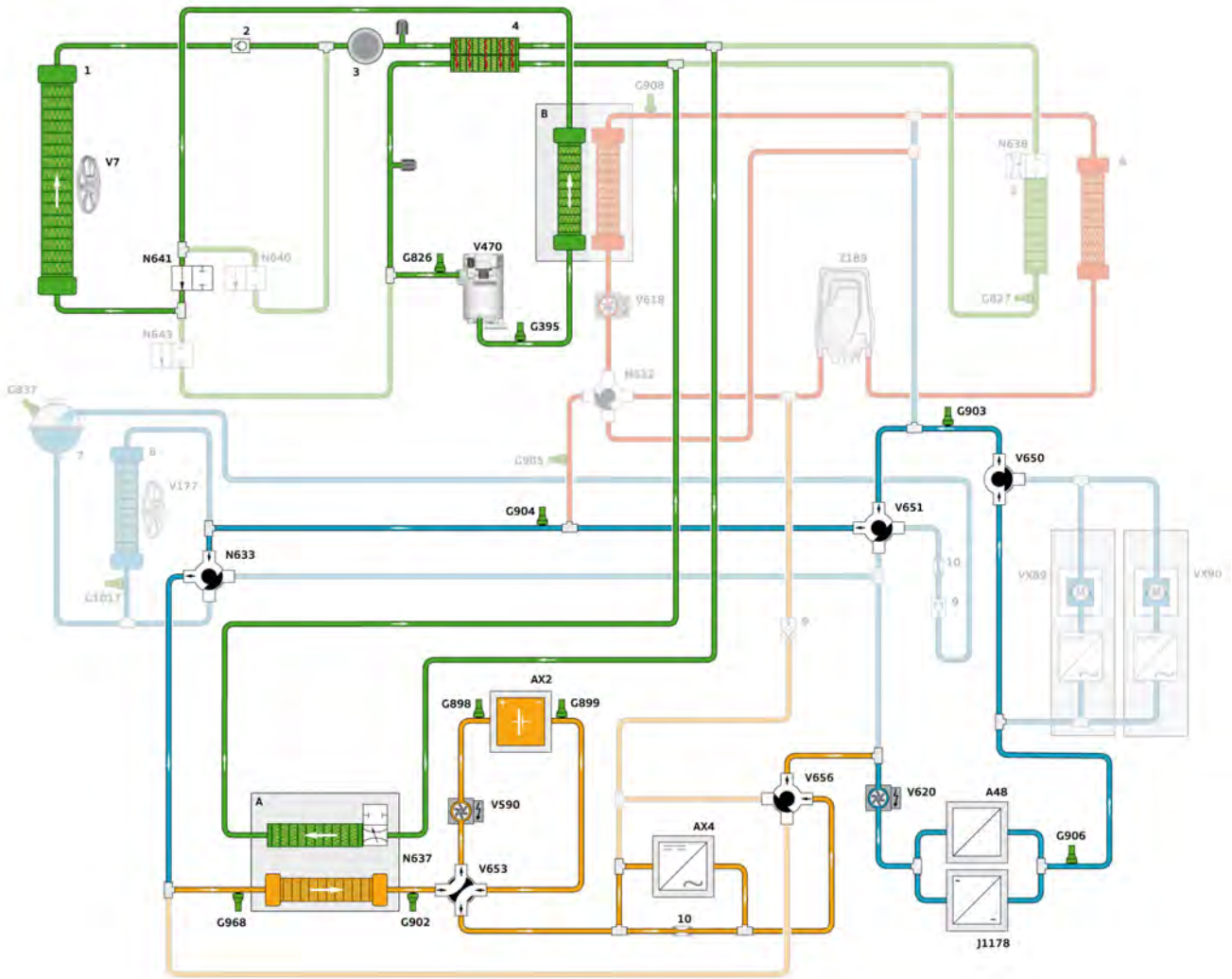

684_036

Coolant pump for high-voltage battery **V590** transports the coolant through high-voltage battery 1 **AX2**, changeover and mixing valve 4 for thermal management **V653**, charging unit 1 for high-voltage battery **AX4** and the restrictor **10** to changeover and mixing valve 7 for thermal management **V656**. From there, the coolant enters the coolant circuit for the electric powertrain. Thermal management coolant pump 4 **V620** also pumps the coolant on through voltage converter for 800 V, 400 V, 48 V, 12 V **A48** and power contactor with boost function **J1178** directly to changeover and mixing valve for thermal management **V650**. The coolant continues through changeover and mixing valve 2 for thermal management **V651** and enters coolant changeover valve 2 **N633**. From there, the coolant is transported to heat exchanger for high-voltage battery **A**, changeover and mixing valve 4 for thermal management **V653** and coolant pump for high-voltage battery **V590**.

The activated refrigerant circuit for cooling the high-voltage battery absorbs the heat from the coolant circuit for high-voltage battery in heat exchanger for high-voltage battery **A** while the refrigerant is vaporising and transfers the heat to the condenser **1**.

Example: Charging high-voltage battery with direct current (DC) while cooling is active

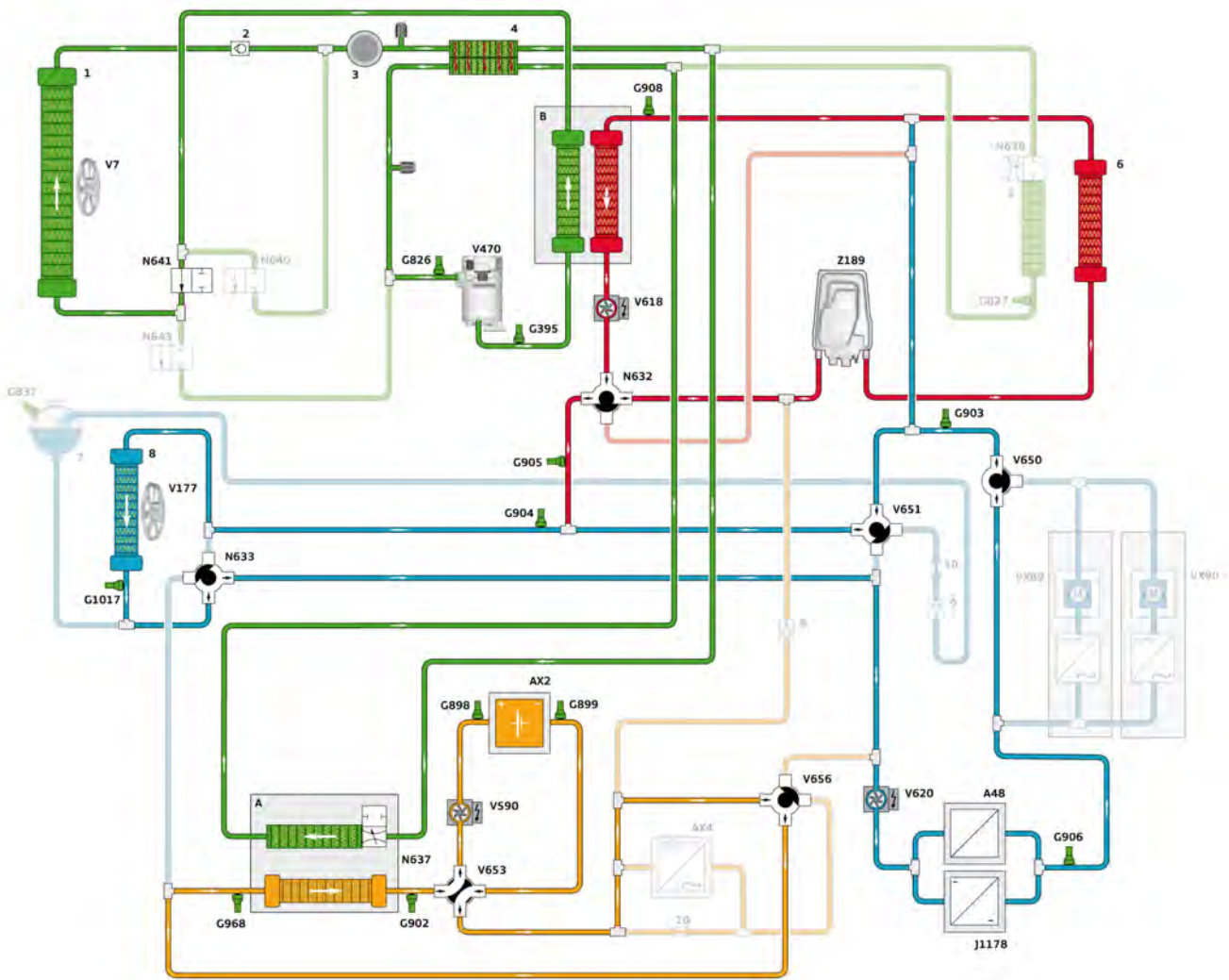

684_037

In the high-voltage battery cooling circuit, the coolant flows through high-voltage battery 1 **AX2**, changeover and mixing valve 4 for thermal management **V653** directly to changeover and mixing valve 7 for thermal management **V656**. From there, it travels through the heat exchanger for high-voltage battery **A**, changeover and mixing valve 4 for thermal management **V653** and to coolant pump for high-voltage battery **V590**. In the heat exchanger for high-voltage battery, the thermal energy from the coolant is transferred to the refrigerant in the refrigerant circuit for cooling high-voltage battery 1 **AX2**. The thermal energy is released into the atmosphere with the help of the condenser **1**.

During DC charging, the coolant circuit for the electric powertrain is also active.

Thermal management coolant pump 4 **V620** pumps coolant through voltage converter for 800 V, 400 V, 48 V, 12 V **A48** and power contactor with boost function **J1178**, directly to changeover and mixing valve for thermal management **V650** and then to mixing valve 2 for thermal management **V651**. The position of coolant changeover valve 2 **N633** regulates the amount of coolant which flows through the low-temperature radiator **8**. The coolant flows back to thermal management coolant pump 4 **V620** from coolant changeover valve 2 **N633**.

A regulated portion of the warm coolant can branch off downstream of changeover and mixing valve for thermal management **V650** into the heating circuit and become mixed with the coolant there. Thermal management coolant pump 2 **V618** transports the coolant through coolant changeover valve 1 **N632** back into the coolant circuit for the electric powertrain.

Safety and driver assist systems

Offer structure for driver assist systems

The offer structure for driver assist systems on the Audi e-tron GT is based on the structure for other models from the second generation of the MLBevo platform that are already in production.

These include the following models:

- › Audi A8 (type 4N)
- › Audi A7 (type 4K)
- › Audi A6 (type 4A)
- › Audi Q8 (type 4M)

The offer structure is also comparable to that for the following models:

- › Audi Q7 (type 4M) after product upgrade
- › Audi e-tron (type GE)

The Audi e-tron GT has the same hardware and software architecture as the models listed above and therefore also offers a comparable range of driver assist systems. The main control unit is driver assist systems control unit J1121 (zFAS control unit). However, there are differences between the individual systems as the basic development of the vehicle took place at Porsche.

The offer structure presented here is designed to provide a general overview of the driver assist systems and pre sense systems that are available for the Audi e-tron GT at the time of its launch. However, the packages presented may vary depending on the country. The reasons for variations may be, for example, that country-specific legislation prevents certain systems being approved or that the Audi customers in the market have different preferences and habits.

Standard equipment

Provided that they are available/approved in the relevant market, the following systems are always fitted as standard:

- › Cruise control system with speed limiter
- › Lane departure warning
- › Parking system plus (eight-channel)
- › pre sense basic
- › pre sense front

Individual options

Provided that they are available/approved in the relevant market, the following systems are offered individually as optional equipment:

- › Reversing camera
- › Overhead view cameras
- › Night vision assist

Assist systems packages

Three assist systems packages are offered for the Audi e-tron GT: parking, city and tour.

The available assist systems packages and the assist systems that they include are described below.

Parking assist package

- › Remote park assist plus
- › Overhead view cameras
- › Maneuver assist

City assist package

- › Lane change warning including rear turn-off assist
- › Exit warning system
- › Rear cross-traffic assist
- › Intersection assist
- › pre sense rear

Tour assist package

- › Adaptive cruise assist
- › Predictive efficiency assist
- › Camera-based traffic sign recognition
- › Emergency assist
- › Main beam assist^[9]

In addition, there is a complete driver assist systems package – the assist package plus – which includes all three of the assist packages described above at a reduced price.

Assist package plus

- > Parking assist package
- > City assist package
- > Tour assist package



Note

The third generation park assist is not offered for the Audi e-tron GT. This was first available in the Audi Q7 (type 4M) in 2015 and then also in second generation MLBevo vehicles. It has been replaced by the park assist plus, which controls the vehicle's longitudinal movement in addition to its lateral movement. This new system is described later in this self-study programme.

Special characteristics of the driver assist systems on the Audi e-tron GT

The following section describes the special characteristics of certain driver assist systems on the Audi e-tron GT where they differ from the implementation on other models based on the second generation of the MLBevo platform.

Lane departure warning

The lane departure warning does not issue a warning via a steering wheel vibration when the vehicle crosses a lane marking. This is due to Audi and Porsche using different steering systems. The steering systems developed by Audi produce the steering wheel vibration via the electric motor in power steering control unit J500.

As a result, the vehicle does not have the corresponding settings under “Lane departure warning” in the profile master for driver assist systems that are used to switch the vibration on and off on other Audi models.

However, steering torque is applied when the vehicle approaches a lane marking in the same way as on other models. The display in the instrument cluster showing the lane markings is also the same. The markings are shown in different colours depending on the system status.

Exit warning system

The exit warning system is implemented in a slightly different way compared to other vehicles based on the second generation of the MLBevo platform. The Audi e-tron GT does not have light strips in the doors that light up in critical situations. All of the other warning mechanisms (such as the lane change warning lamps in the exterior mirrors lighting up or flashing brightly and the delay in opening the doors) are implemented in the familiar way on the Audi e-tron GT.

Adaptive cruise assist

On some models based on the second generation of the MLBevo platform, if a vehicle is ordered with the adaptive cruise assist, a laser scanner is fitted in addition to the long range radar sensor. On the Audi e-tron GT, however, no laser scanner is fitted as the long range radar sensor is sufficient for the adaptive cruise assist. As a result, the narrowed road assist cannot be offered on the Audi e-tron GT.

Since the Audi e-tron GT has a Porsche steering system without a capacitive steering wheel, the hands-off detection uses the data from the steering torque sensors.

Versions of driver assist systems control unit J1121

When the first model based on the second generation of the MLBevo platform – the Audi A8 (type 4N) – was launched in 2017, there were four versions of driver assist systems control unit J1121: versions A0, A, B and C.

The difference between versions A0 and A was that version A also provided the vehicle with camera-based traffic sign recognition. The way in which the installation of camera-based traffic sign recognition is managed has since been changed, meaning that there are now only three different versions: versions A, B and C. The “new” version A is therefore available both with and without camera-based traffic sign recognition.

The control buttons that are familiar from other models based on the second generation of the MLBevo platform are positioned as follows on the Audi e-tron GT.

[9] Depending on the headlight version ordered, the tour assist package will either contain the “digital” main beam assist or the further development of the matrix beam main beam assist.

New position of control buttons for driver assist systems

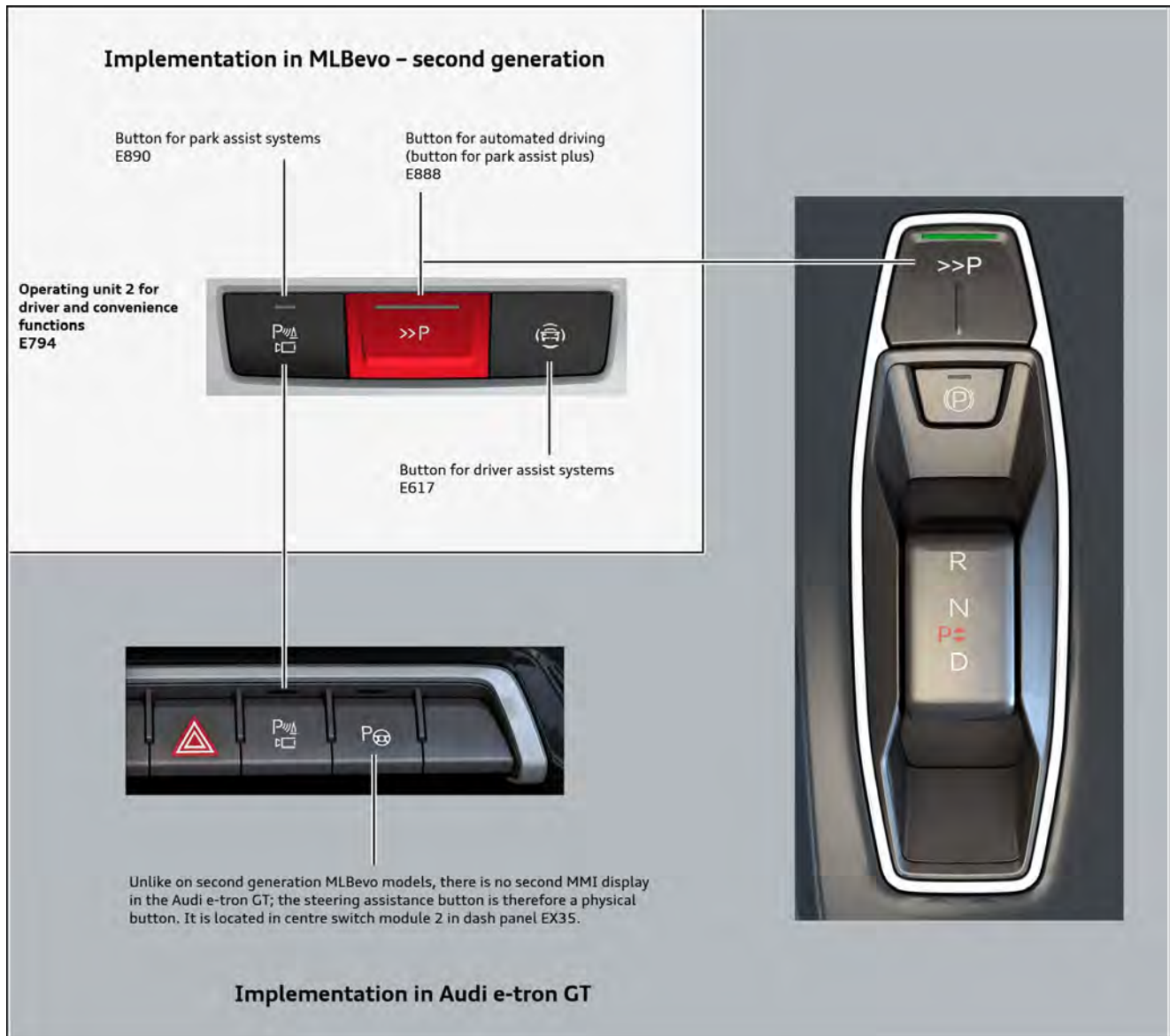

684_042

One of the main differences with regard to how the driver assist systems are operated on the Audi e-tron GT compared to the other vehicles based on the second generation MLBevo platform is that there is no lower MMI display. The Audi e-tron GT is only fitted with the upper MMI display. The second row of buttons (operating unit 2 for driver and convenience functions E794) with the three buttons E617, E888 and E890 is not fitted either.



Note

There is no separate E617 button in the Audi e-tron GT. The profile master for driver assist systems can be accessed via the home button and the “Vehicle” and “Driver assist” tiles on the MMI display.

Fitting locations of sensors and control units

Driver assist systems control unit J1121



Driver assist systems control unit
J1121

684_050

Control unit J1121 is the central control unit for the driver assist systems. It is the master control unit for the following systems:

- > Lane departure warning (version A and above)
- > Emergency assist (version A and above)
- > Lateral guidance (version A and above)
- > Camera-based traffic sign recognition (version A and above)
- > Intersection assist (version B and above)
- > Parking system plus (version C)
- > Overhead view cameras (version C)
- > Maneuver assist (version C)
- > Remote park assist plus/park assist plus (version C)

Mounting for driver assist systems

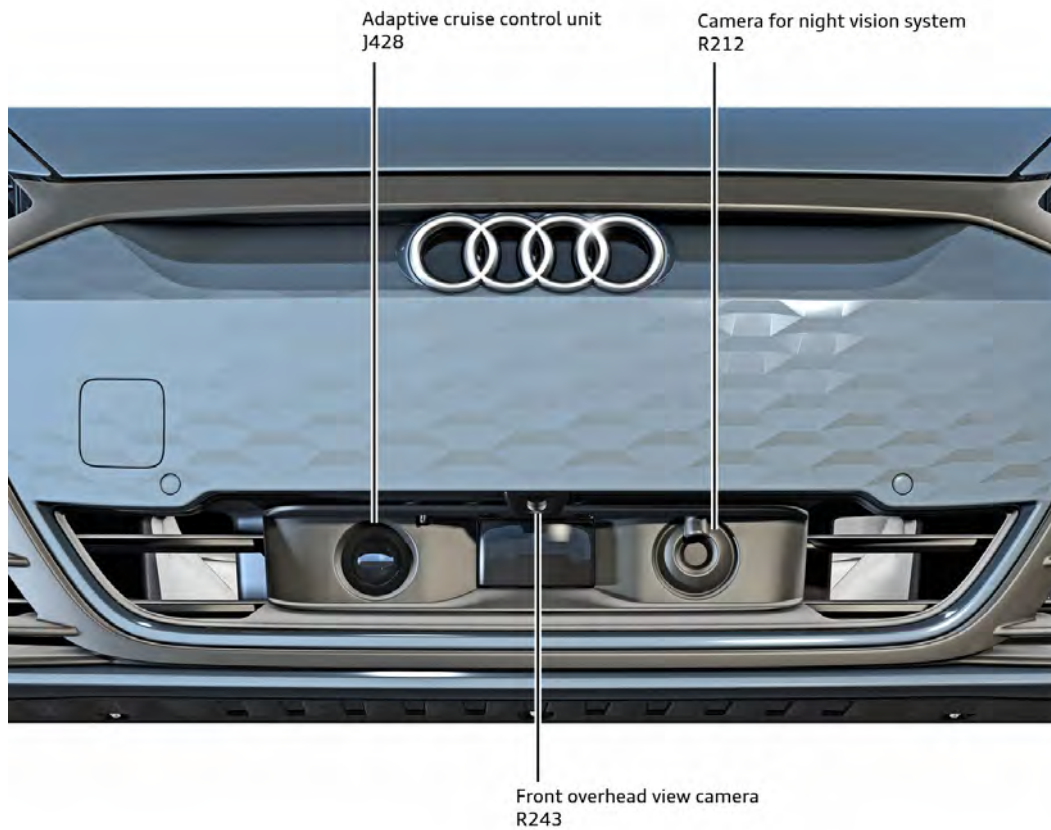

684_043

(adaptive cruise control unit J428, camera for night vision system R212, front overhead view camera R243)



Note

There is a trim panel in the middle of the mounting which looks like the laser scanner introduced on the Audi A8 (type 4N). Despite the trim panel, there are no plans to use the laser scanner on the Audi e-tron GT.

Adaptive cruise control unit J428

Control unit J428 is the master control unit for the following systems:

- > Longitudinal guidance
- > Adaptive cruise assist/cruise control
- > Predictive efficiency assist
- > Swerve assist and turn-off assist (pre sense front)
- > Distance indicator and distance warning

Control unit for night vision system J853

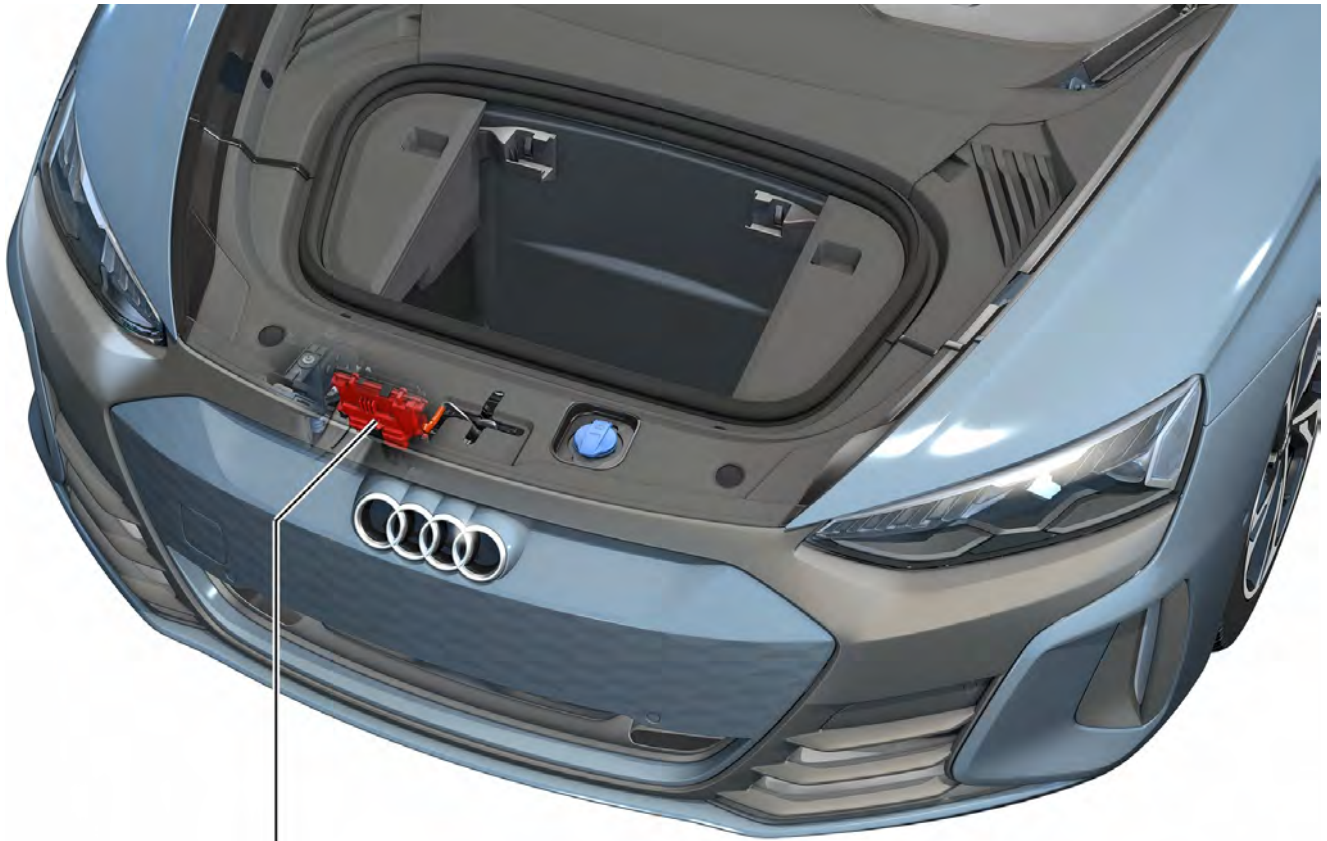

Control unit for night vision system
J853

684_044

Control unit J853 is the master control unit for the following systems:

- › Night vision assist

Front camera for driver assist systems R242

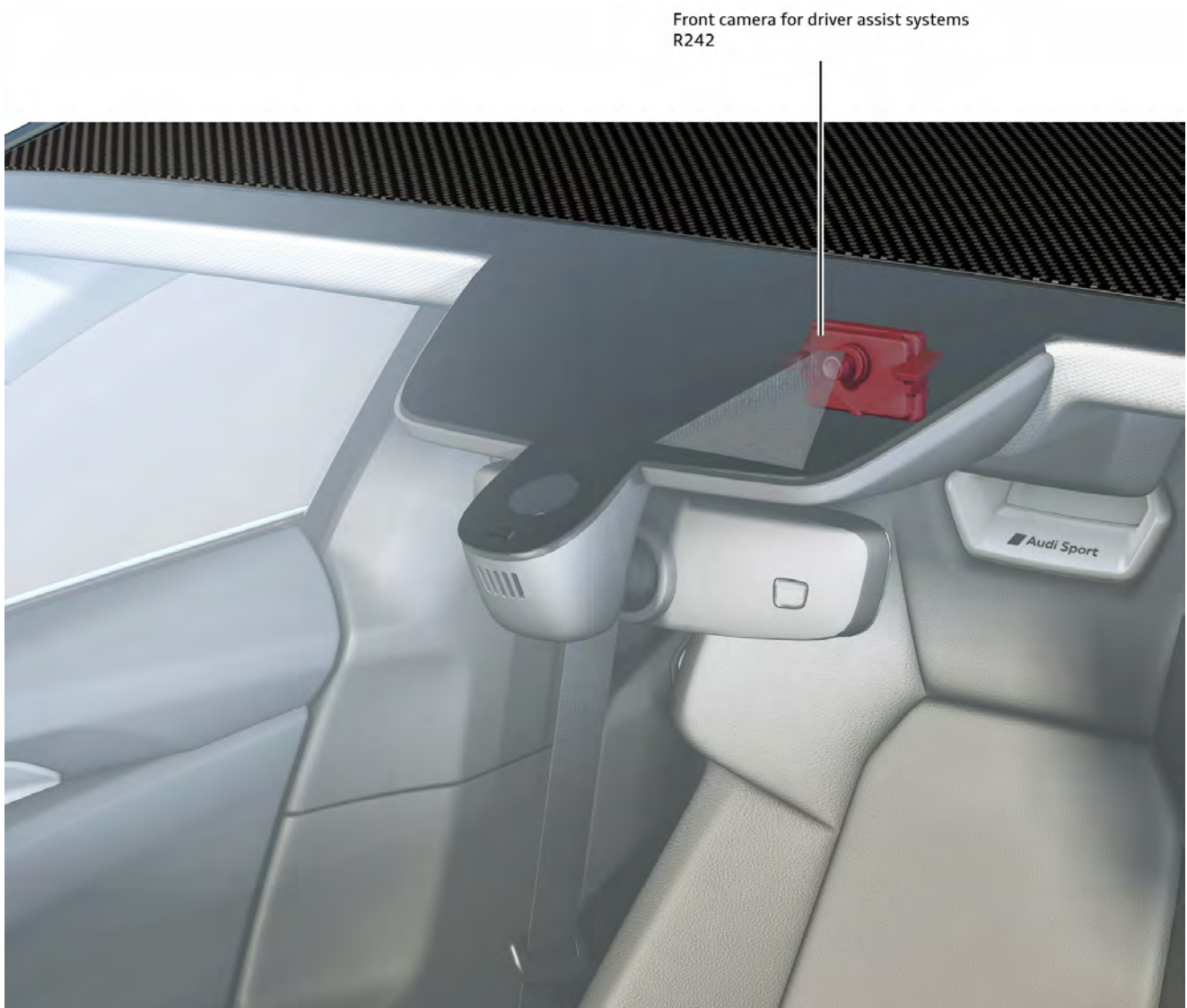

684_047

Front camera for driver assist systems R242 functions only as an image acquisition sensor on the Audi e-tron GT. The camera images are transmitted to driver assist systems control unit J1121 which performs all further steps.

Rear radar sensors (control units J769 and J770)



Right rear radar sensor
(lane change assist control unit 2 J770)

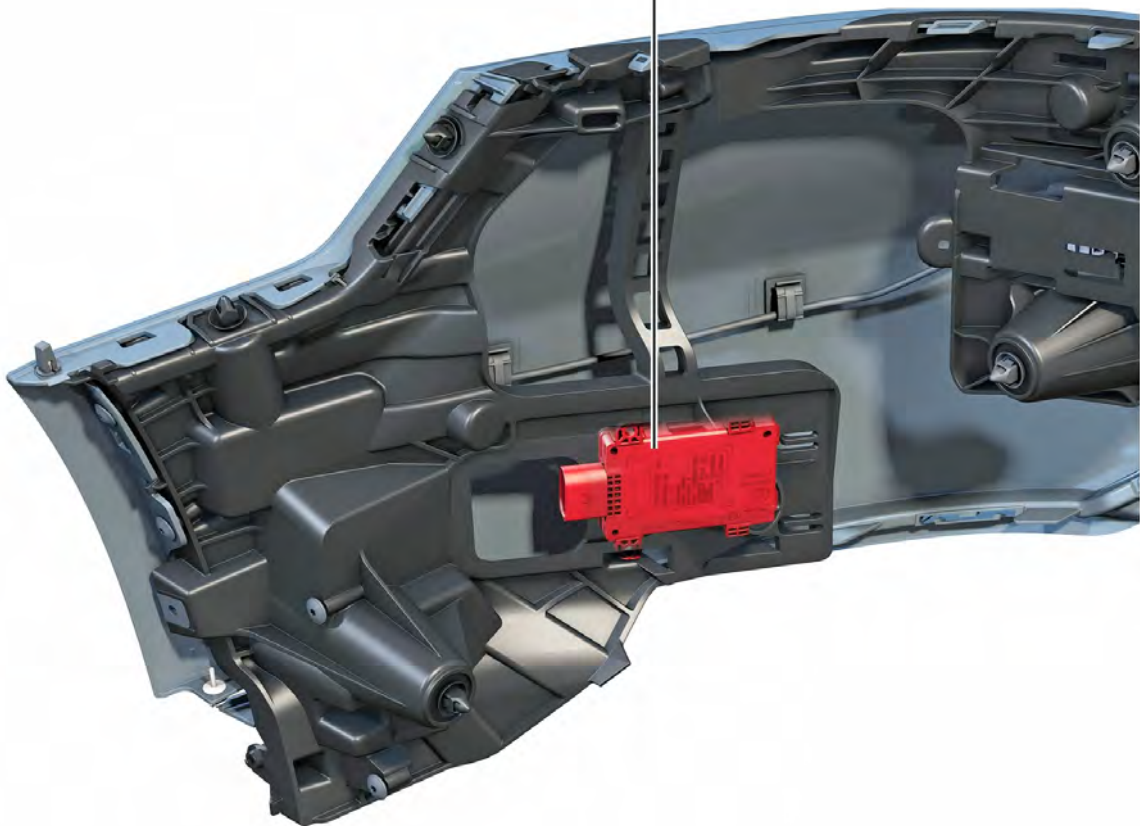

684_046

The rear radar sensors are the master control units for the following systems:

- › Lane change warning

- > Exit warning system
- > Rear cross-traffic assist
- > Rear turn-off assist

Front corner radar sensors (control units J1088 and J1089)



Left front corner radar sensor
(front left radar sensor control unit for object detection J1088)

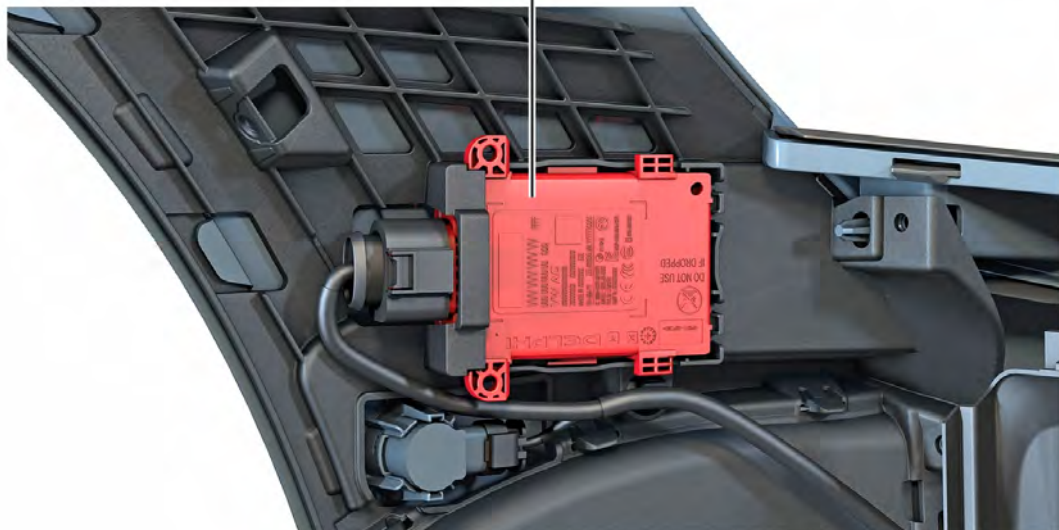

684_045

The front corner radar sensors function only as radar sensors. The sensor signals are processed in driver assist systems control unit J1121. As a result, control unit J1121 is also the master control unit for the intersection assist.

Maneuver assist

How it works

The maneuver assist supports the driver when parking or manoeuvring and when driving forwards or reversing at a low speed. Its task is to use braking interventions to help the driver avoid collisions with static obstacles. If the vehicle has been braked to a standstill due to an obstacle being detected, the maneuver assist is deactivated temporarily if the driver then continues to drive towards the obstacle. This allows the driver to “override” the system, since there is no second braking intervention.

The maneuver assist only works when the parking aid is switched on at speeds of between -10 km/h and +10 km/h.

The maneuver assist is a new Audi driver assist system. It is offered in models whose electronic equipment is based on the second generation of the MLBevo platform. These are as follows:

- > Audi A8 (type 4N)
- > Audi Q8 (type 4M)
- > Audi A7 (type 4K)
- > Audi Q7 (type 4M)
- > Audi A6 (type 4A)
- > Audi e-tron (type GE)
- > Audi e-tron GT (type F8)

PR numbers

Vehicles equipped with the maneuver assist are also always equipped with the park assist plus. For this reason, the maneuver assist does not have its own PR number. A vehicle is equipped with the maneuver assist if one of the following three PR numbers is included in its PR number list: FT1, FT2 or FT3. These are the PR numbers for the different versions of the park assist plus.

Activation

The basic requirement to activate the maneuver assist is that the “maneuver assist” option in the MMI menu for the parking aid is set to “on”.

The maneuver assist is activated when the driver switches the park assist system on by performing one of the following two actions:

- > Engaging reverse gear
- > Pressing the parking aid button

By contrast, when the parking aid is activated automatically as a result of driving forwards slowly, the maneuver assist is not activated. In this case, the driver can activate the system manually by tapping the function symbol displayed on the MMI.

Maneuver assist displays

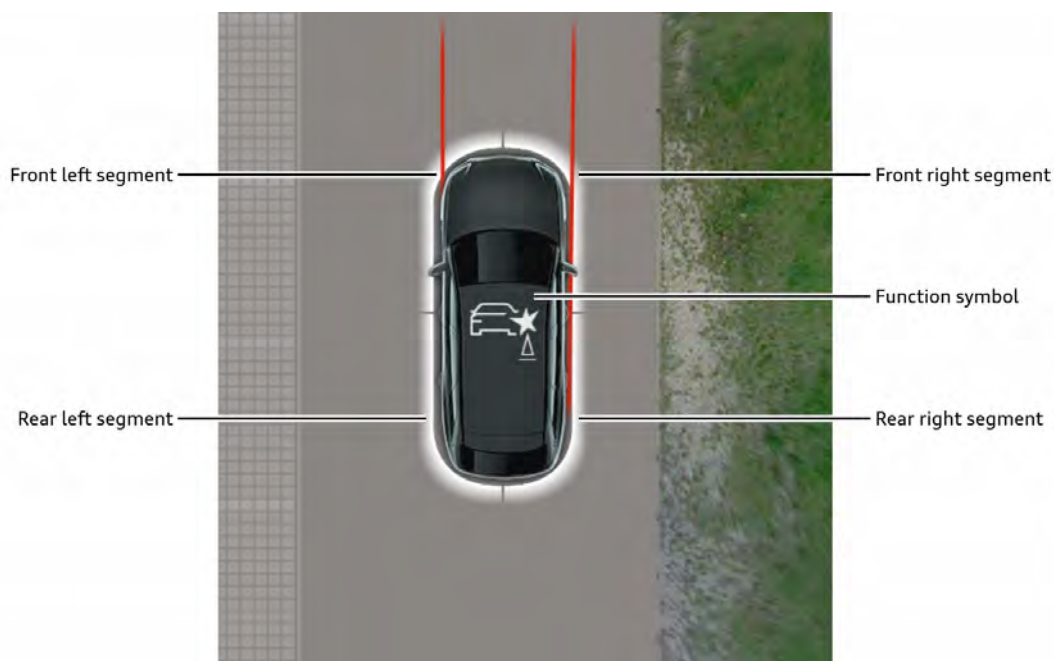

684_099

The current system status of the maneuver assist is indicated on the MMI's parking system display via the function symbol for the maneuver assist. This is shown on the roof of the vehicle displayed on the MMI. In addition, four segments are shown around the vehicle at the front left, front right, rear left and rear right.

Possible statuses of the function symbol

- The function symbol is white and not crossed out maneuver assist is active
- The function symbol is white and crossed out maneuver assist has been deactivated temporarily
- The function symbol is not shown The maneuver assist has been switched off in the MMI or the system is unavailable due to a technical fault
- The function symbol is grey and crossed out When a speed of 10 km/h is exceeded when reversing

Possible statuses of the four segments

- Segment is white Corresponding area is currently being monitored
- Segment is not shown Corresponding area is not currently being monitored
- Segment is red Protective braking has occurred due to an obstacle being detected in the corresponding area

Example maneuver assist displays



- System status:**
- > maneuver assist active
 - > Monitoring is active at front left and right and rear left and right



- System status:**
- > maneuver assist temporarily inactive
 - > Possible cause: Deactivation by the driver



- System status:**
- > maneuver assist temporarily inactive due to driving forwards at >10 km/h



- System status:**
- > maneuver assist temporarily inactive due to reversing at >10 km/h

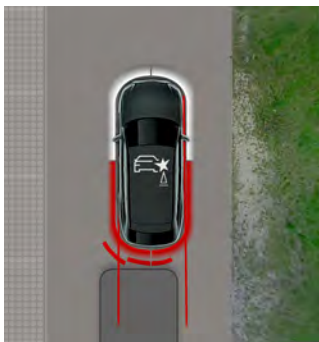

- System status:**
- > maneuver assist active
 - > Protective braking has occurred due to one or more objects being detected in rear left and right areas

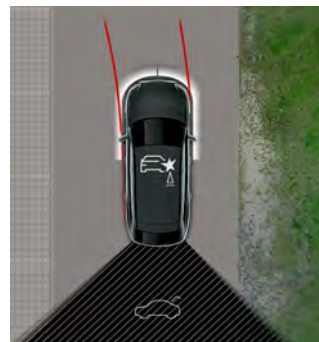

- System status:**
- > maneuver assist only active at front as boot lid is open
 - > maneuver assist inactive at rear

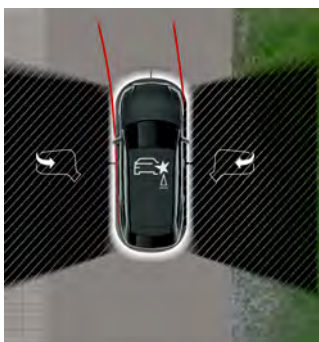

- System status:**
- > maneuver assist active
 - > Exterior mirrors are currently folded in



- System status:**
- > maneuver assist temporarily inactive as driver's door is open

Sensors and hardware

The software of the maneuver assist is integrated in driver assist systems control unit J1121. The maneuver assist function requires the following sensors:

- > 12 sixth generation ultrasonic sensors
- > 4 overhead view cameras, the images from which are processed in control unit J1121

Due to the required sensors, version C of driver assist systems control unit J1121 is required for the system.



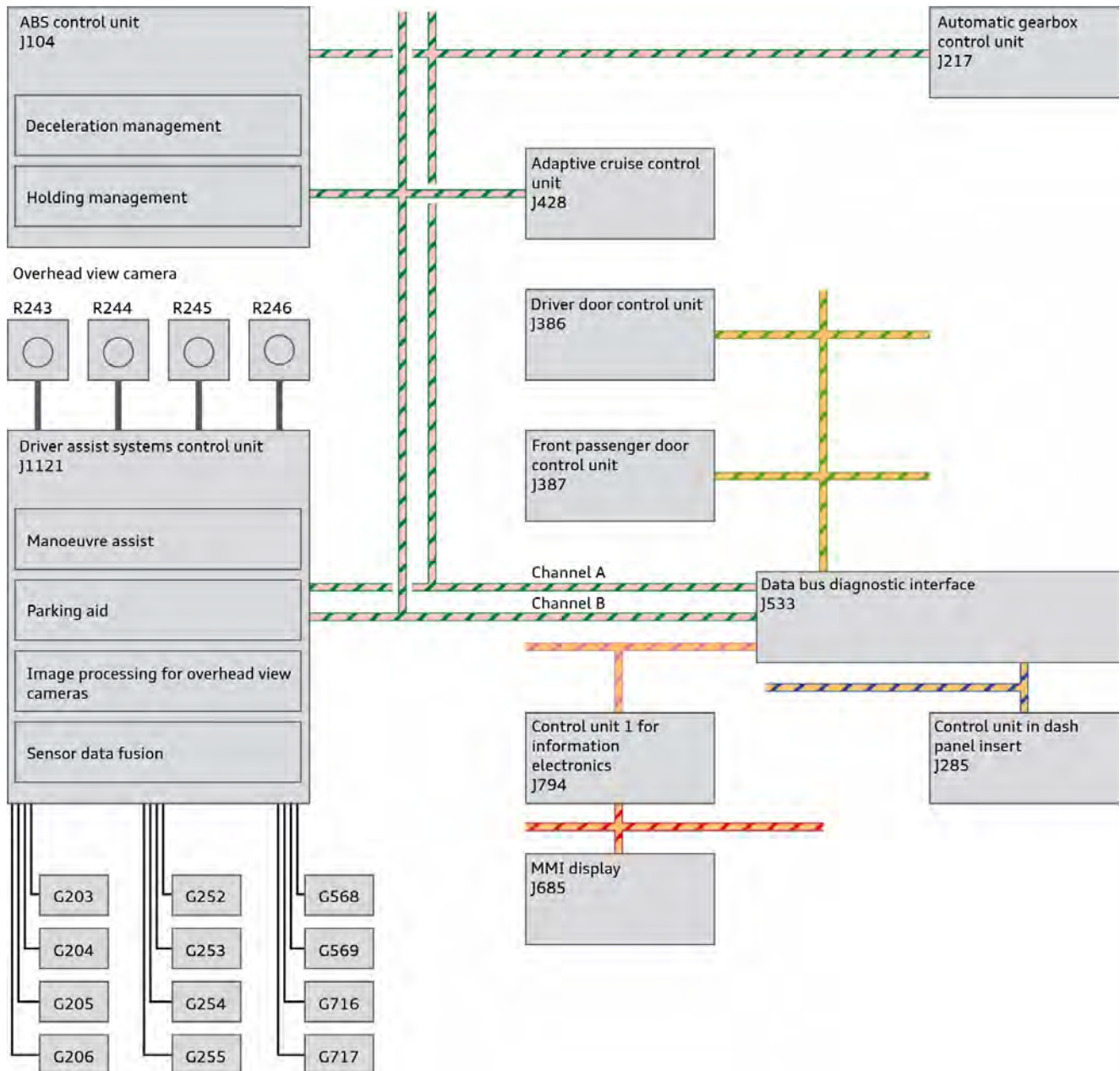

Networking



684_038

Key:

- G203 ... G206** Rear parking aid senders
- G252 ... G255** Front parking aid senders
- G568 ... G569** Front side park assist steering senders
- G716 ... G717** Rear side park assist steering senders
- R243** Front overhead view camera
- R244** Left overhead view camera
- R245** Right overhead view camera
- R246** Rear overhead view camera

	Convenience CAN
	Infotainment CAN
	Dash panel insert CAN
	Information electronics 1 CAN
	FlexRay

The illustration shows the control units that are involved in the maneuver assist. The main tasks of the individual control units are explained below. The master control unit for the maneuver assist is driver assist systems control unit J1121.

Control units and their tasks

Driver assist systems control unit J1121

- › Is the master control unit for the maneuver assist
- › Is the master control unit for the parking aid
- › Reads in the sensor signals from the ultrasonic sensors and evaluates them
- › Receives the camera images from the four overhead view cameras and processes them
- › Extracts objects from the camera images received from the overhead view cameras and localises them within the technical limits
- › Enters all available sensor data in a shared internal map (sensor data fusion)
- › Initiates braking to bring the vehicle to a standstill in critical situations via control unit J104
- › Initiates corresponding displays for the maneuver assist on the MMI and in the instrument cluster

ABS control unit J104

- › Implements braking interventions requested by the system
- › Keeps the vehicle stationary after a protective braking intervention has brought it to a standstill

Automatic gearbox control unit J217

- › Transmits the current transmission position (the maneuver assist is always deactivated in transmission position N so as to avoid protective braking when the vehicle is inside a car wash)

Adaptive cruise control unit J428

- › Transmits whether the adaptive cruise assist is currently active. The maneuver assist must be deactivated when the adaptive cruise assist is active.

Control unit 1 for information electronics J794

- › Sends the maneuver assist's display content to the upper MMI display
- › Sends the information to control unit J1121 when the MMI display registers that a soft key has been pressed

Control unit in dash panel insert J285

- › Displays messages for the maneuver assist

MMI display J685

- › Displays the driver messages for the maneuver assist
- › Displays the graphics for the parking aid/the image from the overhead view cameras in which maneuver assist information is also shown
- › Registers when soft keys on the MMI display that affect the maneuver assist are pressed

Driver and front passenger door control units J386 and J387

- › Put the current status of the driver's and front passenger's doors ("door open/door closed") on the convenience CAN bus
- › Put the current status of the exterior mirrors ("left/right exterior mirror folded in/not folded in") on the convenience CAN bus

In both cases, the image from the affected overhead view camera must be excluded from the calculations.

Data bus diagnostic interface J533

- › Is the interface between the different vehicle bus systems
- › Routes relevant information from one bus system to one or more other bus systems



Reference

For further information on the maneuver assist, please refer to SSP 667 "Audi - new park assist systems 2020" (refer to article "").

Park assist plus

Introduction

The park assist plus makes parking incredibly convenient. It guides the vehicle into parking spaces parallel or perpendicular to the road by taking over the steering, acceleration, braking and changes of transmission position.

The driver monitors the parking maneuver while sitting in the vehicle as he/she is still fully responsible for it. To allow the driver to monitor the vehicle's surroundings better, the image from the overhead view cameras is shown on the MMI display throughout the maneuver. All vehicles with the park assist plus are also equipped with the optional overhead view cameras.

The procedure for searching for suitable parking spaces is the same as for the third generation park assist that was introduced in 2015 on the Audi Q7 (type 4M). It is carried out by measuring parking spaces with the front side ultrasonic sensors as the vehicle passes them. The geometrical requirements that a parking space must fulfil are also the same as for the third generation park assist.

The system detects suitable parking spaces parallel or perpendicular to the road even if the driver has not yet activated the park assist plus display. Suitable parking spaces are always detected as long as the vehicle's speed remains below 45 km/h. The system always searches on both sides of the vehicle.

If the driver would like to use one of the parking spaces offered, he/she begins driving into it until prompted by the system to brake the vehicle to a standstill. If several parking spaces are offered, the driver can choose whether to use the parking space prioritised by the system or select a different identified parking space on the MMI. To start the parking maneuver with the park assist plus, the driver must take both hands off the steering wheel, press the brake pedal and then press the park assist plus button. The system starts the parking maneuver as soon as the driver releases the brake pedal. The driver must keep holding the button down during the entire parking maneuver. By continuing to hold the button down, the driver signals to the system that he/she is monitoring the maneuver and that the system should continue with it.

If the driver identifies a hazard during the parking maneuver, he/she can let go of the button to interrupt the maneuver at any time. If the interruption does not last too long, he/she can then continue with the parking maneuver by pressing the button again. If the interruption lasts for a longer period, the park assist plus ends the maneuver by applying the electromechanical parking brake, selecting transmission position P and then deactivating the drive system.

Similarities and differences compared to the third generation park assist

The park assist plus works in a similar way to the familiar third generation park assist. However, the driver receives considerably more assistance from the park assist plus compared to the third generation park assist. The system now takes complete control of the longitudinal movement of the vehicle and activates the overhead view camera display on the MMI. Nevertheless, the driver must still monitor the automatic parking maneuvers. This is important because he/she retains full responsibility for the entire parking maneuver.

To enable a better understanding of the new parking system, the main similarities and differences between the park assist plus and the third generation park assist are described below. The comparison refers to the technical status of the two systems on vehicles based on the second generation of the MLBevo platform (model year 2021).

Similarities between the park assist plus and the third generation park assist

- › Park assist display activated on MMI by pressing button for steering assist
- › Parking space search runs continuously on both sides of the vehicle whenever the vehicle is moving in the corresponding speed range
- › Desired parking scenario selected on MMI
- › The system takes over the steering for the different parking scenarios.
- › The driver takes full responsibility for the parking maneuver. For this reason, the driver must monitor the vehicle's surroundings carefully and act accordingly in the event of any hazards.
- › Both systems support the following parking scenarios:
 - › Reversing into a parking space parallel to the road
 - › Reversing into a parking space perpendicular to the road
 - › Driving forwards into a parking space perpendicular to the road after driving past it
 - › Driving forwards directly into a parking space perpendicular to the road
- › Both systems support driving forwards out of a parking space parallel to the road
- › Criteria for a suitable parking space parallel to the road:
 - › When parking: length of parking space parallel to the road \geq vehicle length + 90 cm
 - › When driving out of a parking space (unparking): length of parking space parallel to the road \geq vehicle length + 50 cm
- › Criteria for a suitable parking space perpendicular to the road:
 - › When parking: width of parking space perpendicular to the road \geq vehicle width + 95 cm

Differences compared to the third generation park assist

Park assist plus

Level 2 driver assist system

System takes complete control of longitudinal movement of the vehicle. The driver only needs to hold a button down during the parking maneuver

After the parking maneuver has been completed successfully, the system engages the parking lock and the electromechanical parking brake.

Third generation park assist

Level 1 driver assist system

The driver is responsible for longitudinal movement of the vehicle.

After the parking maneuver has been completed successfully, the driver must select transmission position P and engage the parking brake himself/herself.

Park assist plus

The master control unit is driver assist systems control unit J1121 – version C.

Uses 12 sixth generation ultrasonic sensors

The system is linked to the optional overhead view cameras.

In addition to the measurement data from the 12 ultrasonic sensors, the system also uses data from the overhead view cameras via sensor data fusion.

PR numbers: 7X5 and FT3/FT1

Third generation park assist

The master control unit is onboard supply control unit J519

Uses 12 fifth generation ultrasonic sensors

The system works independently of the overhead view cameras.

The system only uses the measurement data from the 12 ultrasonic sensors.

PR numbers: 7X5 and FT0

Parking scenarios for the park assist plus

The park assist plus supports exactly the same parking scenarios as the third generation park assist. A schematic overview of all supported parking scenarios is provided in the diagram below.

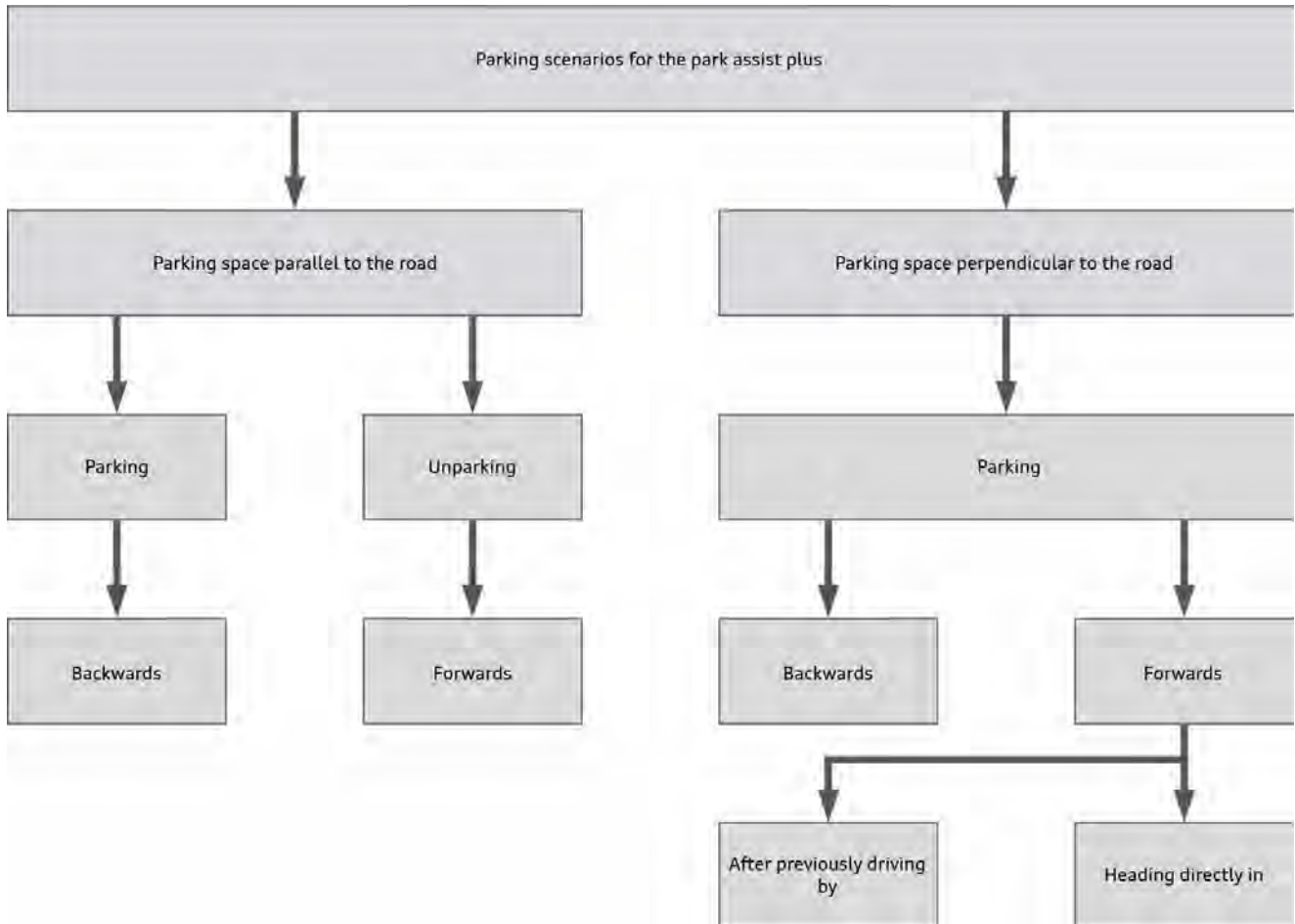

684_039

Displays and operation

The park assist plus searches for parking spaces on both sides of the road when the vehicle's speed is below 45 km/h. The parking space search runs automatically in the background and does not have to be activated by the driver. To use the park assist plus, the driver must then activate the park assist plus display.

There are two ways of activating the park assist plus display:

1. Pressing the button for steering assist in the row of buttons on the centre console



684_049

or

2. Pressing the soft key for steering assist in the parking aid display on the MMI. In this case, the parking aid must already be active.

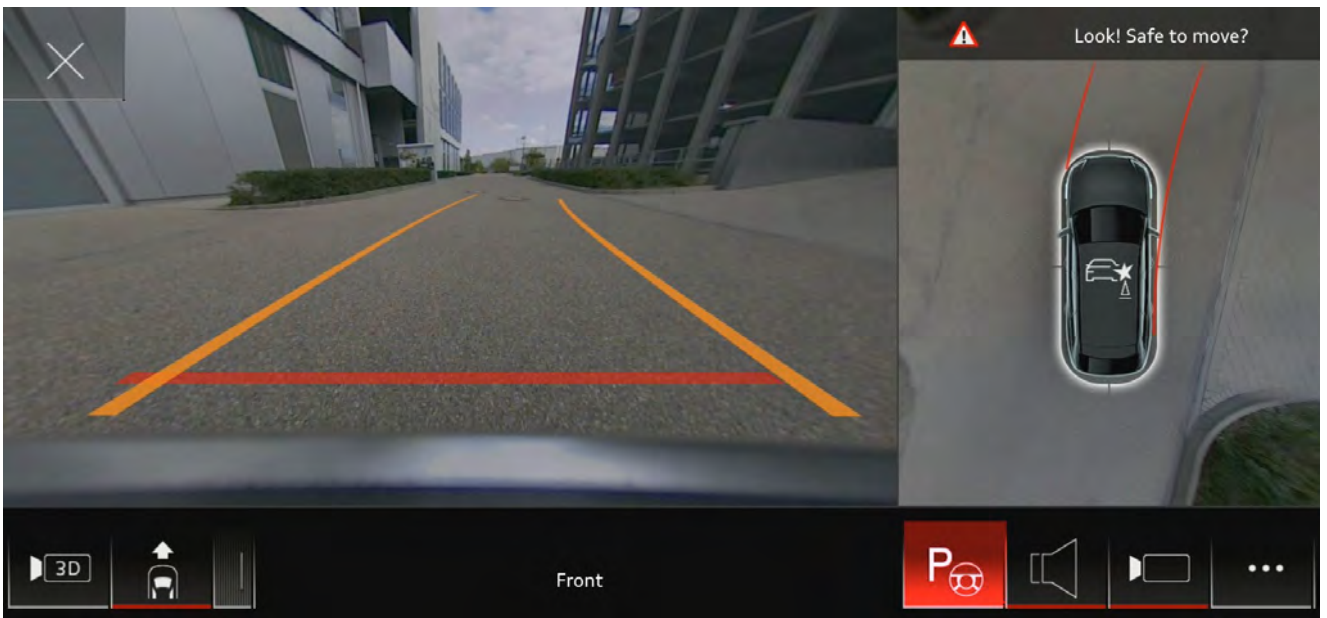

684_230

Park assist plus button (E888)



684_048

The park assist plus button (button for automated driving E888) is the main control for the park assist plus. It is located above the selector lever and marked with “>>P”.

Firstly, this button allows the driver to have a parking maneuver performed but also to interrupt it quickly if necessary. The driver must keep holding the button during the entire parking maneuver. Secondly, the LED integrated in the button indicates the current status of the function.

The LED can indicate the following statuses:

- | | |
|------------------------------|---|
| LED flashing in white | The park assist plus is ready to start the parking maneuver or to resume after an interruption. |
| LED lit up in green | The system is currently performing a parking maneuver. |
| LED lit up in red | The park assist plus has aborted or completed the current parking maneuver. |

A parking maneuver may be aborted for the following reasons:

- > The driver braked the vehicle to a standstill.
- > The driver intervened in the steering.
- > The driver pressed the accelerator.
- > The system was switched off manually.
- > The defined time limit was exceeded.
- > The maximum permissible number of possible manoeuvring movements was reached.
- > The current parking maneuver cannot be continued due to an obstacle.
- > The ESC intervened.



Note

With the park assist plus, the driver remains fully responsible for the parking maneuvers, even though they are controlled by the system.

Hardware and sensors

Driver assist systems control unit J1121



684_051

The master control unit for the park assist plus is driver assist systems control unit J1121. It was first introduced on the Audi A8 (type 4N) launched in 2017. Control unit J1121 integrates several control units that were separate on other models into one central driver assist systems control unit. This enables the data from many sensors to be processed centrally in one control unit, eliminating the need for them to first be transmitted via bus systems, as well as the associated delay.

Due to the large number of driver assist systems that can be ordered, several versions of driver assist systems control unit J1121 were developed. The higher the number of driver assist systems fitted in a vehicle, the higher the version required. The basic version is called version A. As the number of driver assist systems in a vehicle increases, version B or C of the control unit becomes necessary.

The park assist plus requires version C of control unit J1121.

Central sensor technology for the park assist plus

For the park assist plus to plan its parking maneuver in the best possible way, the system requires detailed information about the vehicle's surroundings. The park assist plus receives this information from the following sensors:

- › 12 sixth generation ultrasonic sensors
(G203, G204, G205, G206, G252, G253, G254, G255, G568, G569, G716, G717)
- › 4 overhead view cameras
(R243 - R246)

The image data from the overhead view cameras are analysed by image processing software in control unit J1121 which searches for objects in the images and fuses these data with the data from the ultrasonic sensors. Using and fusing data from two completely different types of sensor increases the quality of the data used to calculate parking maneuvers.



Reference

For further information on driver assist systems control unit J1121, please refer to SSP 668 "Audi A8 (type 4N) (refer to chapter "Driver assistance systems control unit J1121")."

Networking of sensors with master control unit J1121

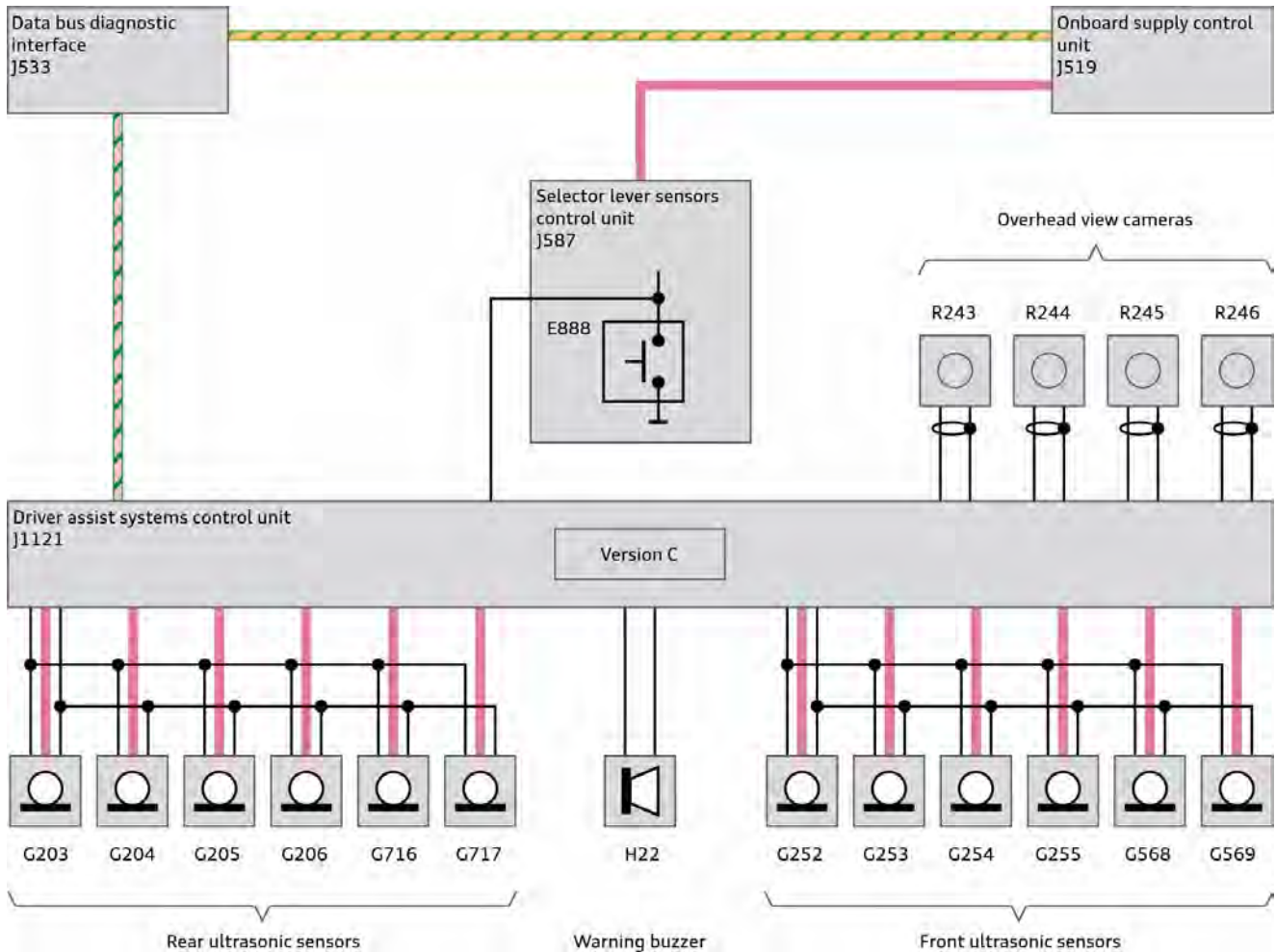

684_040

Key:

E888	Button for automated driving
G203	Rear left parking aid sender
G204	Rear centre left parking aid sender
G205	Rear centre right parking aid sender
G206	Rear right parking aid sender
G252	Front right parking aid sender
G253	Front centre right parking aid sender
G254	Front centre left parking aid sender
G255	Front left parking aid sender
G568	Front left sender for park assist steering on left side of vehicle
G569	Front right sender for park assist steering on right side of vehicle
G716	Rear left park assist steering sender
G717	Rear right park assist steering sender
H22	Front parking aid warning buzzer
J587	Selector lever sensors control unit
R243	Front overhead view camera
R244	Left overhead view camera
R245	Right overhead view camera
R246	Rear overhead view camera
	Convenience CAN



The 12 ultrasonic sensors and the 4 overhead view cameras are read in directly by control unit J1121.

The park assist plus button (button for automated driving E888) is read in by control unit J1121 via a separate signal wire. To check the plausibility of this signal, the control unit also receives the status of the button from onboard supply control unit J519 via the vehicle bus system.



Reference

For further information on park assist plus, please refer to SSP 667 "Audi - new park assist systems 2020" (refer to chapter "").

Remote park assist plus

Introduction

The remote park assist plus is an enhanced version of the park assist plus. It has all the functions of the park assist plus and also offers the following:

- > Additional option to control all parking maneuvers offered by the park assist plus via smartphone app from outside the vehicle.
- > The following additional scenarios for driving out of a parking space (unparking scenarios):
 - > Remote-controlled unparking in reverse for parking spaces perpendicular to the road
 - > Remote-controlled unparking forwards for parking spaces perpendicular to the roadThese two additional unparking scenarios are only possible with remote control.

The two additional unparking scenarios

The two additional unparking scenarios assist the driver in situations where it is not possible to open the doors wide enough to get into the vehicle easily due to a lack of space. In these situations, the remote park assist plus offers the option to drive the vehicle far enough out of the space via remote control (forwards or in reverse) to allow the driver to get in comfortably.

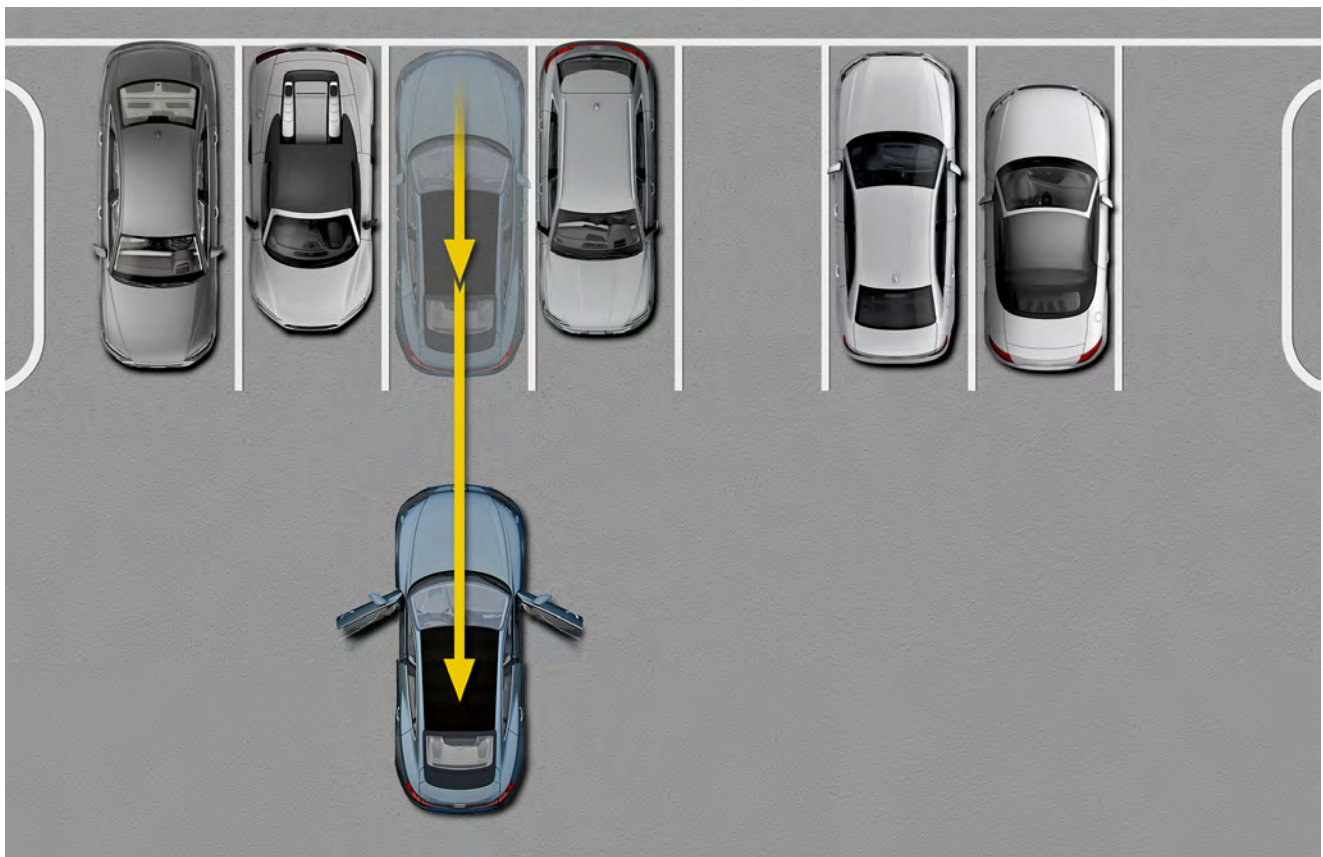

684_221

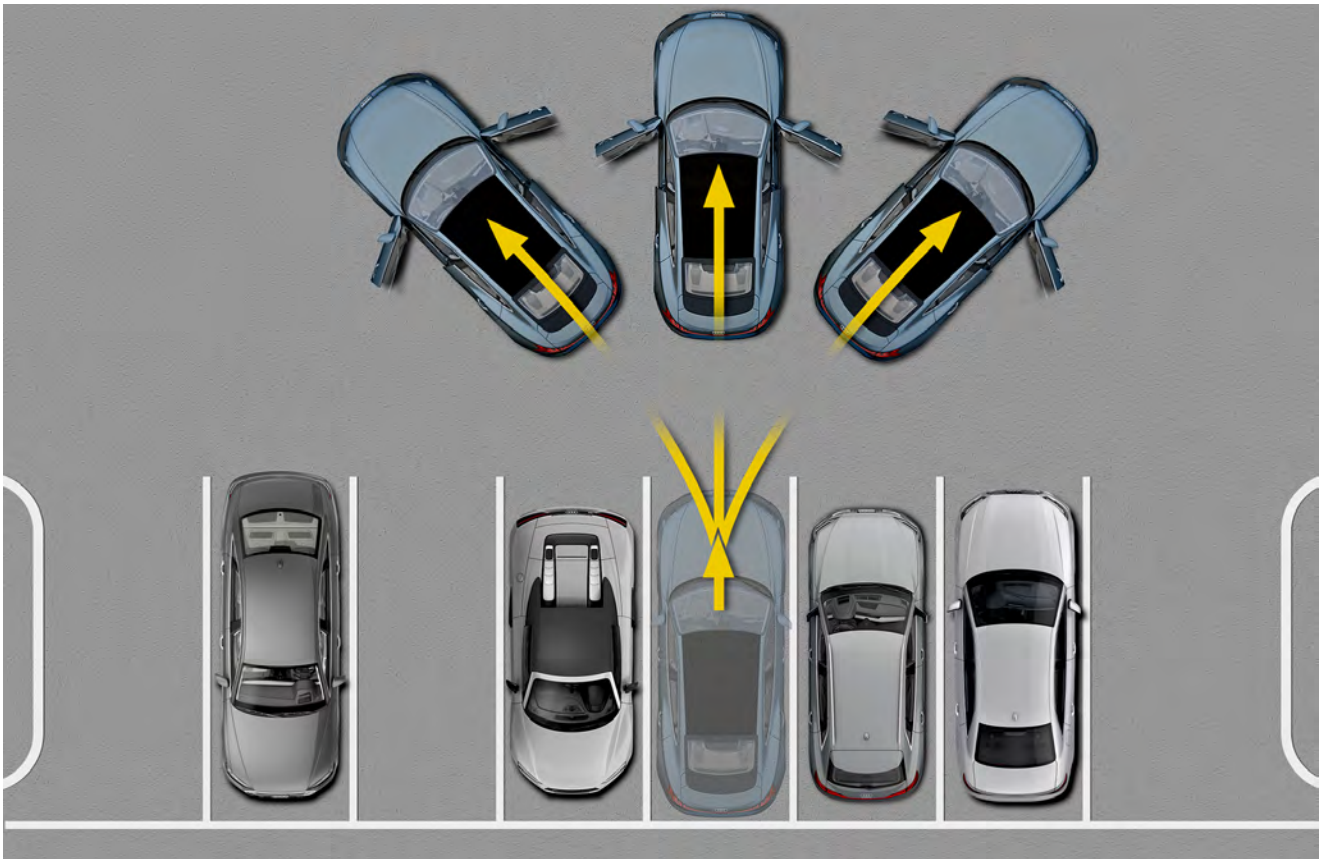

684_222

For remote-controlled forwards unparking for parking spaces perpendicular to the road, the driver can also choose whether the vehicle should drive forwards to the left, in a straight line or to the right. During remote-controlled unparking in reverse with the remote park assist plus, the vehicle always drives in a straight line. The driver determines how far the vehicle drives out of the parking space by how long he/she holds the button.



Note

With the remote park assist plus, the driver remains fully responsible for the parking maneuvers, even though they are controlled by the system.

The remote parking maneuver

Due to technical requirements and also for reasons of safety, certain specifications apply with regard to how far away from the vehicle the driver may be standing when activating the vehicle’s drive system and during the subsequent parking maneuver.

The distance between the driver and the vehicle is determined via the vehicle key using the process that is familiar from the convenience key system.

When activating the vehicle’s drive system

When activating the vehicle’s drive system to perform an unparking maneuver, the vehicle key must be no further than 3 metres away from the vehicle. This is due to the exchange of immobiliser data between the vehicle and the vehicle key.

When performing the manoeuvre

During the subsequent maneuver, the driver must be no further than 6 metres away from the vehicle. If he/she exceeds this distance, the maneuver is interrupted.

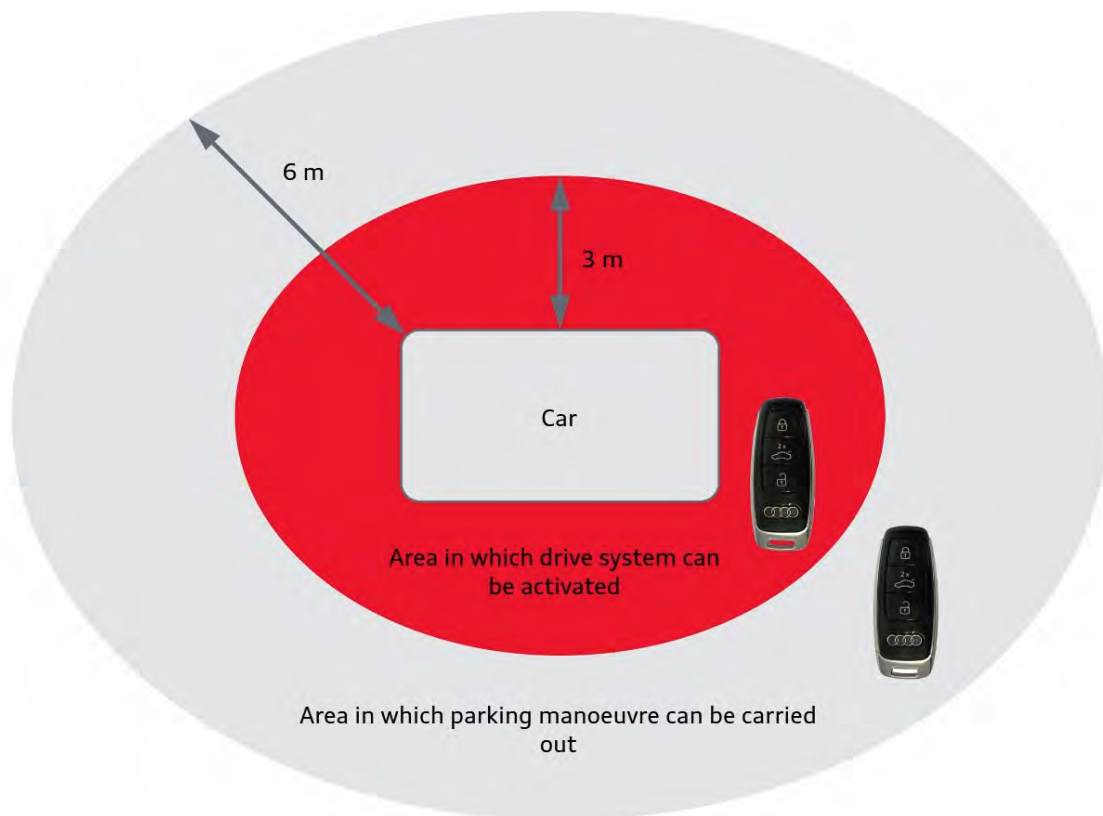

684_223

Interruption of a remote-controlled parking maneuver by the driver

To avoid interruptions to a parking maneuver that is being performed by the remote park assist plus, the driver must keep holding the button on the smartphone's screen throughout. If he/she takes his/her finger off the button, the parking maneuver is interrupted and the vehicle is braked to a standstill. This allows the driver to stop the vehicle immediately at any time, just as he/she is able to do by letting go of the button for the park assist plus E888 when sitting in the vehicle while a parking maneuver is being performed. In both cases, the driver can resume the parking maneuver within approximately 45 seconds by pressing and holding the button again.

For remote-controlled parking, there is a second way of interrupting a parking maneuver:

By pressing any button on the vehicle key.

This means that two separate options are available to interrupt the parking maneuver at any time in the event of a hazard.

Changing from control in the vehicle to remote control

If the driver starts a parking maneuver with the remote park assist plus while sitting in the vehicle, he/she can still exit the vehicle and complete it from there. To do so, the parking maneuver must first be interrupted by releasing the button for the park assist plus E888. The driver must then press the smartphone button on the MMI display, exit the vehicle and close the door. Provided that he/she starts the myAudi app directly afterwards, the parking maneuver can be completed via remote control.



Reference

Before a vehicle can be parked remotely with the remote park assist plus, the myAudi app must be installed on the user's smartphone and an adaption procedure must have been carried out. The precise process will be explained in a separate Service TV programme.

For further information on the Bluetooth Low Energy antennas, their fitting locations and the coupling process, please refer to chapter (refer to chapter "Infotainment and Audi connect") of this self-study programme.

Additional hardware for the remote park assist plus

Compared to the basic version, the remote park assist plus requires four additional hardware components in order to implement all of its functions.

These are:

An additional antenna for the convenience key system:

- › Front antenna for entry and start authorization R376

Two additional antennas and a control unit for communication between the smartphone and the vehicle:

- › antennas 3 and 4 for radio-controlled parking R361 and R362 and
- › Control unit for radio-controlled parking J1182

Front antenna for entry and start authorization R376

Vehicles with the remote park assist plus must also have the optional convenience key. This is required to locate the vehicle key outside the vehicle and calculate its distance from the vehicle.

For the standard convenience key, which is only used for the keyless entry system, the vehicle key only needs to be identified in certain areas outside the vehicle – not all the way around it. Four antennas are sufficient for this purpose. There is no need for an additional antenna that covers the area in front of the vehicle if the park assist plus is not fitted.

If a vehicle is fitted with a remote control parking system, an additional antenna is required to cover the area in front of the vehicle. The antenna that performs this task is front antenna for entry and start authorization R376. This additional entry and start authorization antenna enables the distance between the vehicle key and the vehicle to be measured all the way around the vehicle.

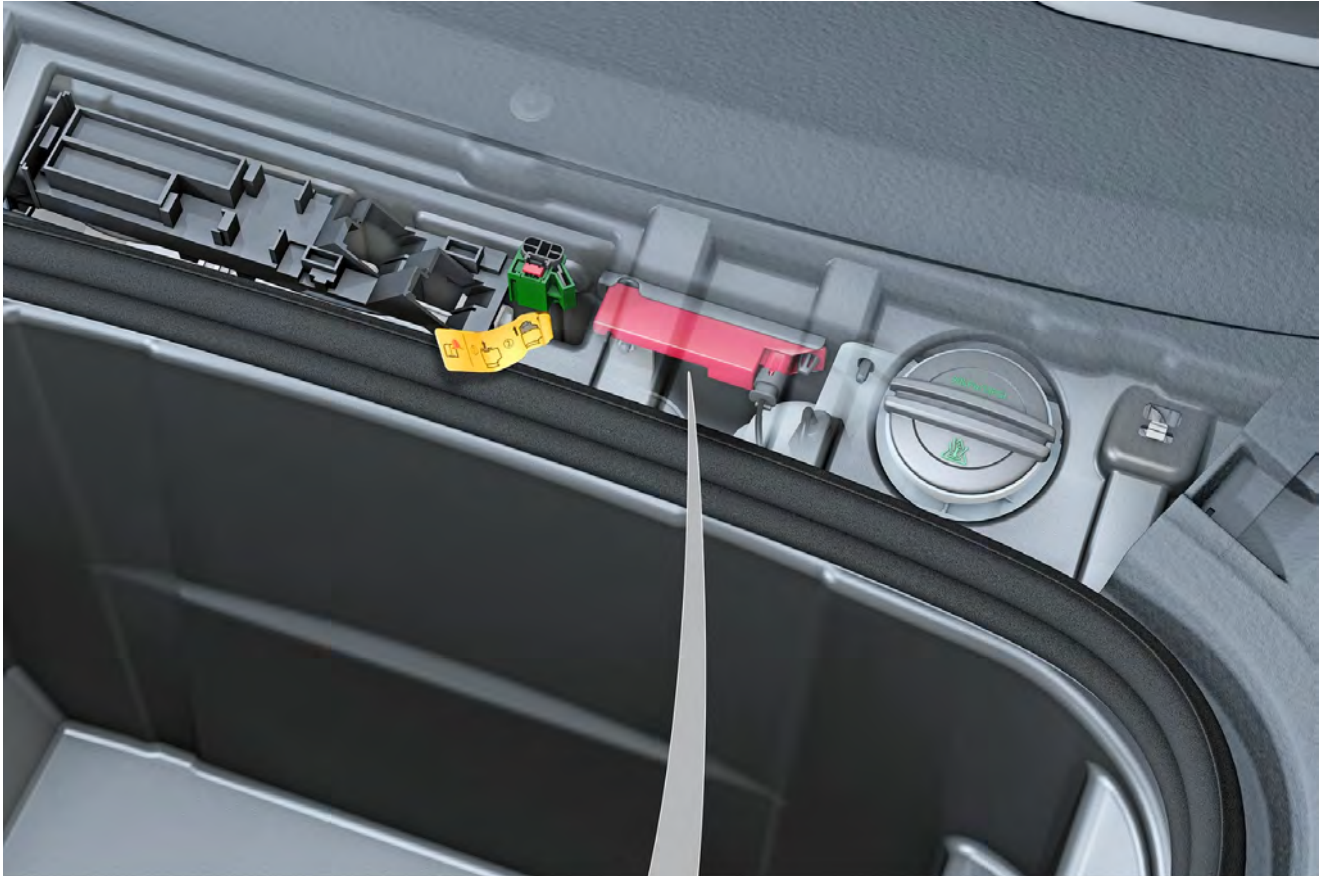

Front aerial for entry and start authorisation
R376



684_229

Control unit for radio-controlled parking J1182

To enable a parking maneuver to be controlled from outside the vehicle, data must be transmitted securely from the smartphone to the master control unit J1121 in the vehicle, and vice versa. Outside the vehicle, data are transmitted wirelessly, while inside the vehicle they are transmitted via the electrical signal wires of the vehicle bus system. Control unit for radio-controlled parking J1182 is the interface between wireless data transmission and data transmission via wires. The Audi e-tron GT is the first vehicle to be fitted with this control unit.

Control unit for radio-controlled parking J1182 sends data to and receives data from the smartphone via its two Bluetooth antennas R361 and R362. Control unit J1182 sends data to and receives data from the master control unit for the new park assist systems (driver assist systems control unit J1121) via CAN bus messages on the infotainment CAN.

Control unit for radio-controlled parking J1182

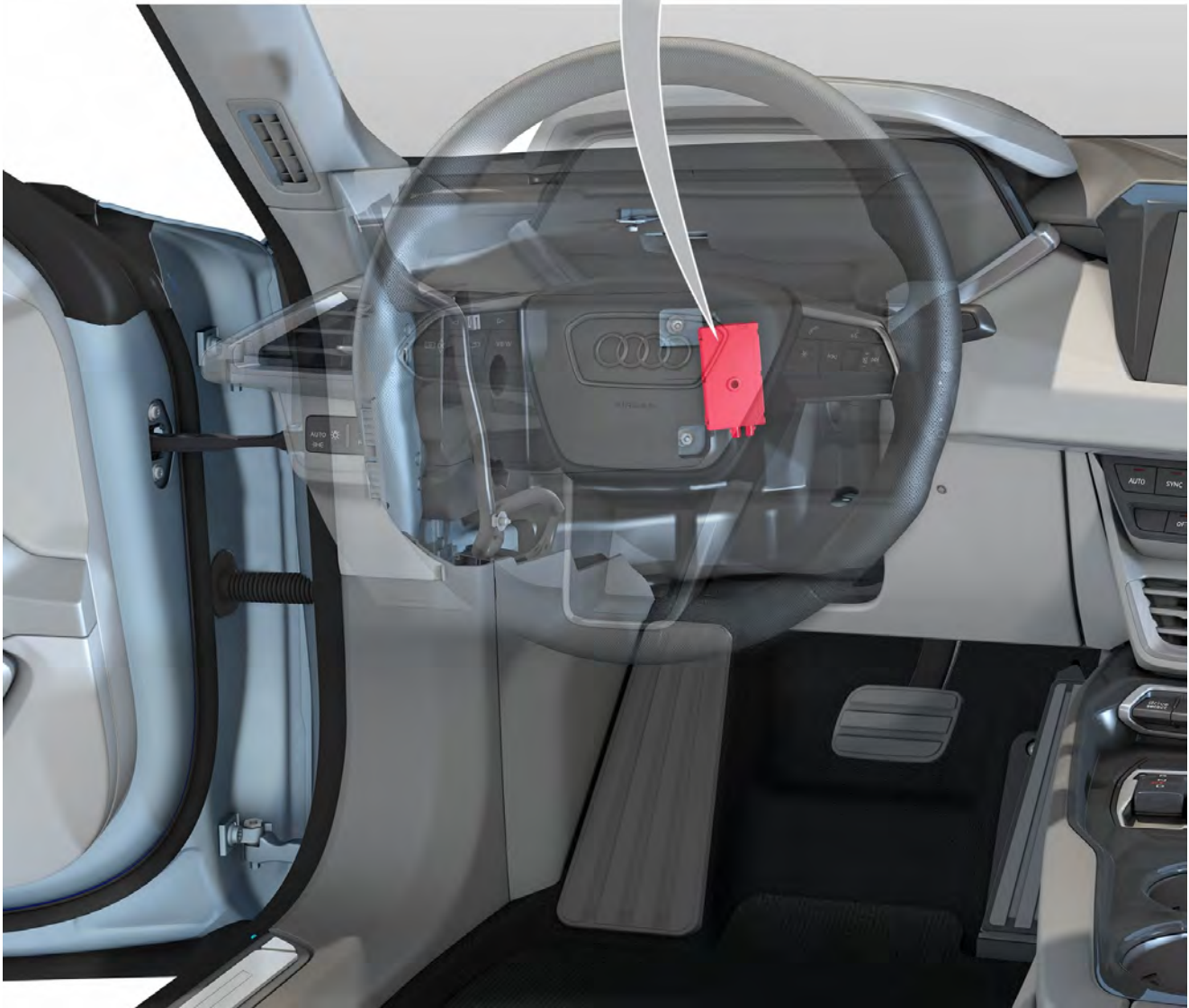

684_225

Electrical connections on control unit for radio-controlled parking J1182

Four electrical wires and two antenna wires are connected to control unit for radio-controlled parking:

- > Two power supply wires
- > Two infotainment CAN wires
- > Two screened antenna wires to antennas R361 and R362

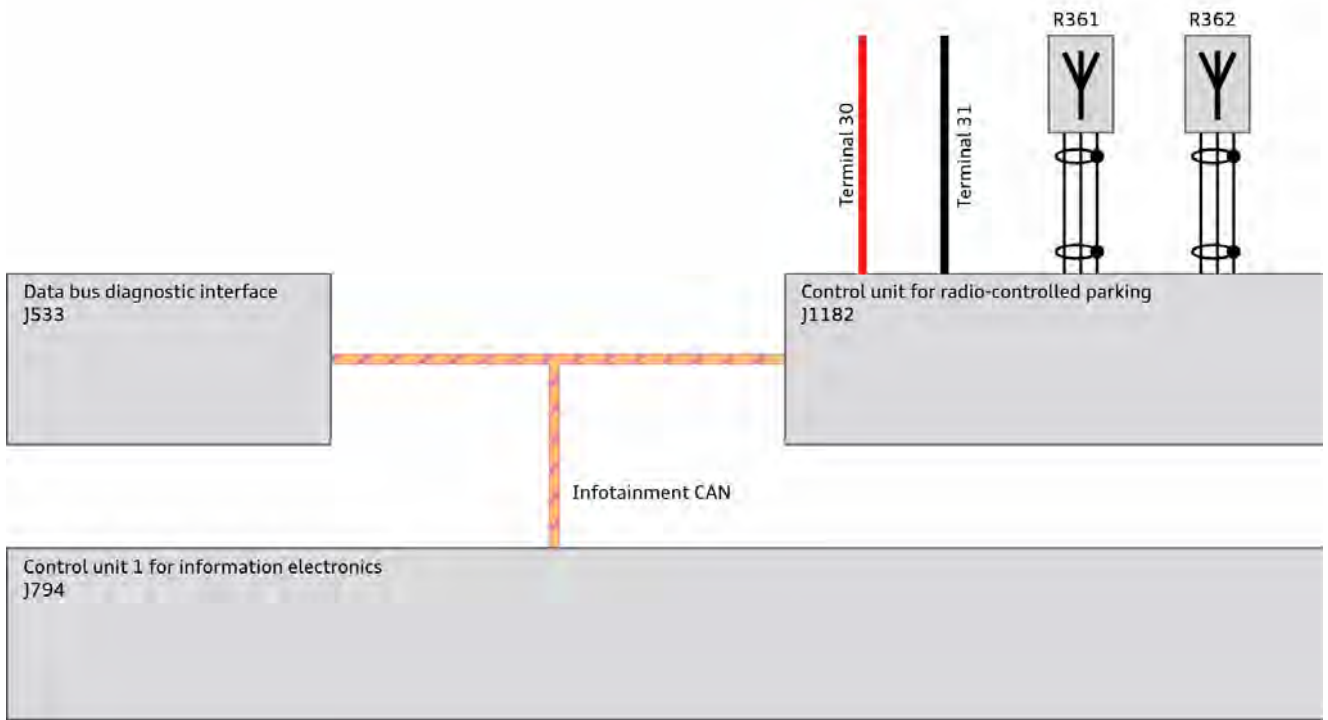

684_326

Key:

- R361** antenna 3 for radio-controlled parking
- R362** antenna 4 for radio-controlled parking

Communication between the park assist systems and the smartphone

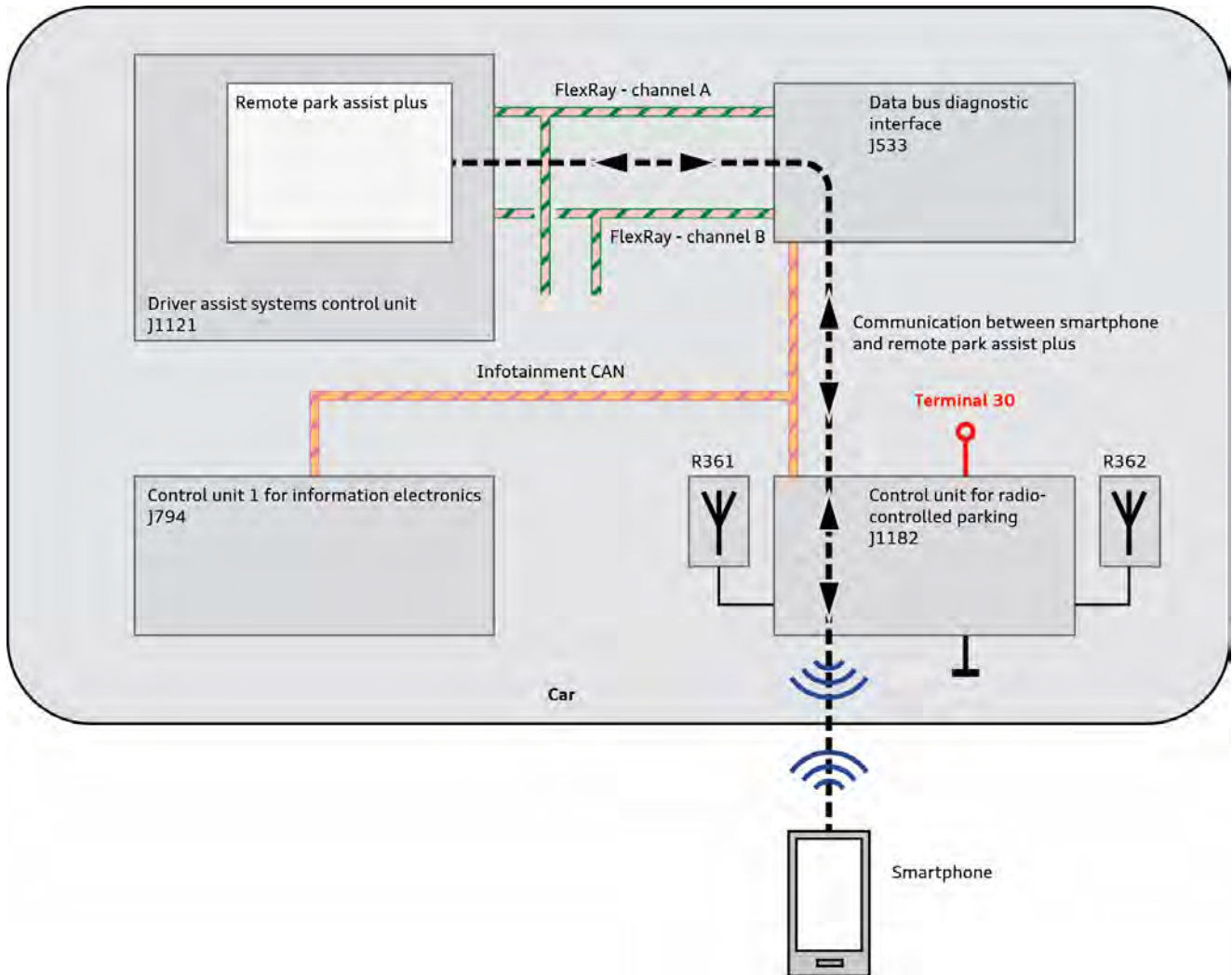

684_227

Data are exchanged between the park assist systems integrated in control unit J1121 and the smartphone via various vehicle bus systems and control units, as well as a Bluetooth connection.

1. The master control unit for the park assist systems (driver assist systems control unit J1121) communicates with data bus diagnostic interface J533 via FlexRay channels A and B.
2. Data bus diagnostic interface J533 communicates with control unit for radio-controlled parking J1182 via the infotainment CAN bus.
3. Control unit for radio-controlled parking J1182 exchanges information with the smartphone via a specific type of Bluetooth connection, a Bluetooth Low Energy connection.

Bluetooth Low Energy

Bluetooth Low Energy is a radio technology that can be used to network devices within a range of approximately 10 metres of each other. Compared to standard Bluetooth, Bluetooth Low Energy consumes significantly less power and is also less expensive. Bluetooth Low Energy is also known as Bluetooth Smart or ultra low power Bluetooth. All three terms are simply different names for the same technology.

Bluetooth Low Energy is suitable for wireless data transfer for remote-controlled parking because it meets the quiescent current requirements specified by Audi and because the volume of data exchanged between the parking system and the smartphone is not very high.

Passive safety

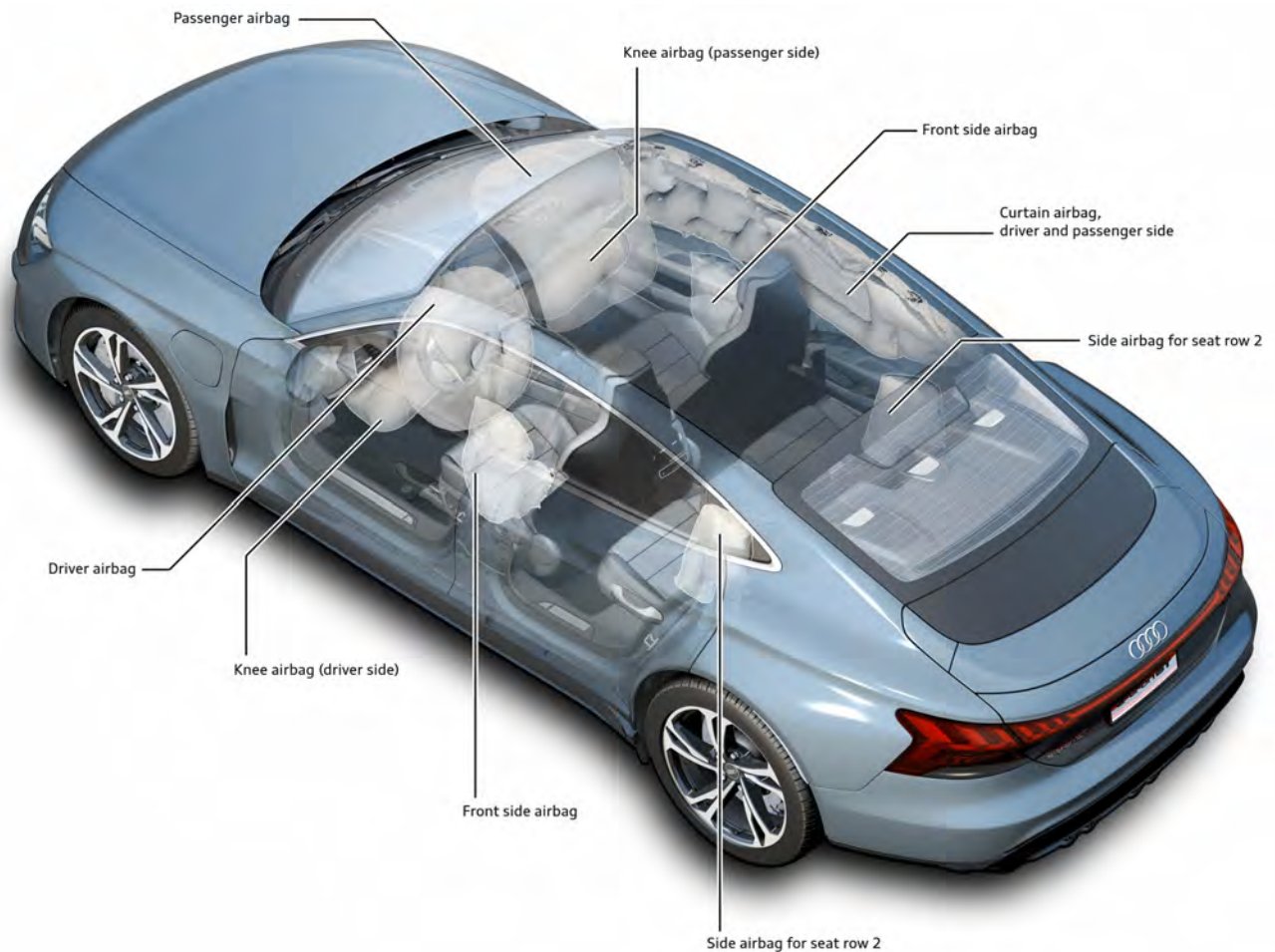

684_181

The following sections provide an overview of the occupant protection system in the Audi e-tron GT (type F8).

Components

Depending on country version and vehicle equipment, the passive occupant and pedestrian protection system in the Audi e-tron GT (type F8) may comprise the following components and systems:

- › Airbag control unit
- › Adaptive driver airbag
- › Adaptive passenger airbag (two-stage passenger airbag)
- › Front side airbags
- › Side airbags for seat row 2
- › Curtain airbags
- › Knee airbags
- › Crash sensors for front airbags
- › Crash sensors for side impact detection in doors
- › Crash sensors for side impact detection in C-pillars
- › Crash sensors for side impact detection in B-pillars
- › Crash sensors for power and control electronics at front end and rear cross panel
- › Front belt retractors with pyrotechnic belt tensioners
- › Front belt retractors with electric belt tensioners
- › Front belt retractors with switchable belt force limiters
- › Belt retractors for seat row 2 with pyrotechnic belt tensioners for driver and passenger side
- › Front lap belt tensioners for driver and passenger sides
- › Seat belt warning for all seats
- › Seat-occupied recognition system in passenger seat
- › Key-operated switch to deactivate airbag on front passenger side
- › Front passenger airbag warning lamp (OFF and ON)
- › Seat position detection for driver and passenger
- › Battery isolator, high-voltage system

**Note**

The images in the “Passive safety” chapter are schematic diagrams and are provided to aid understanding.

System overview

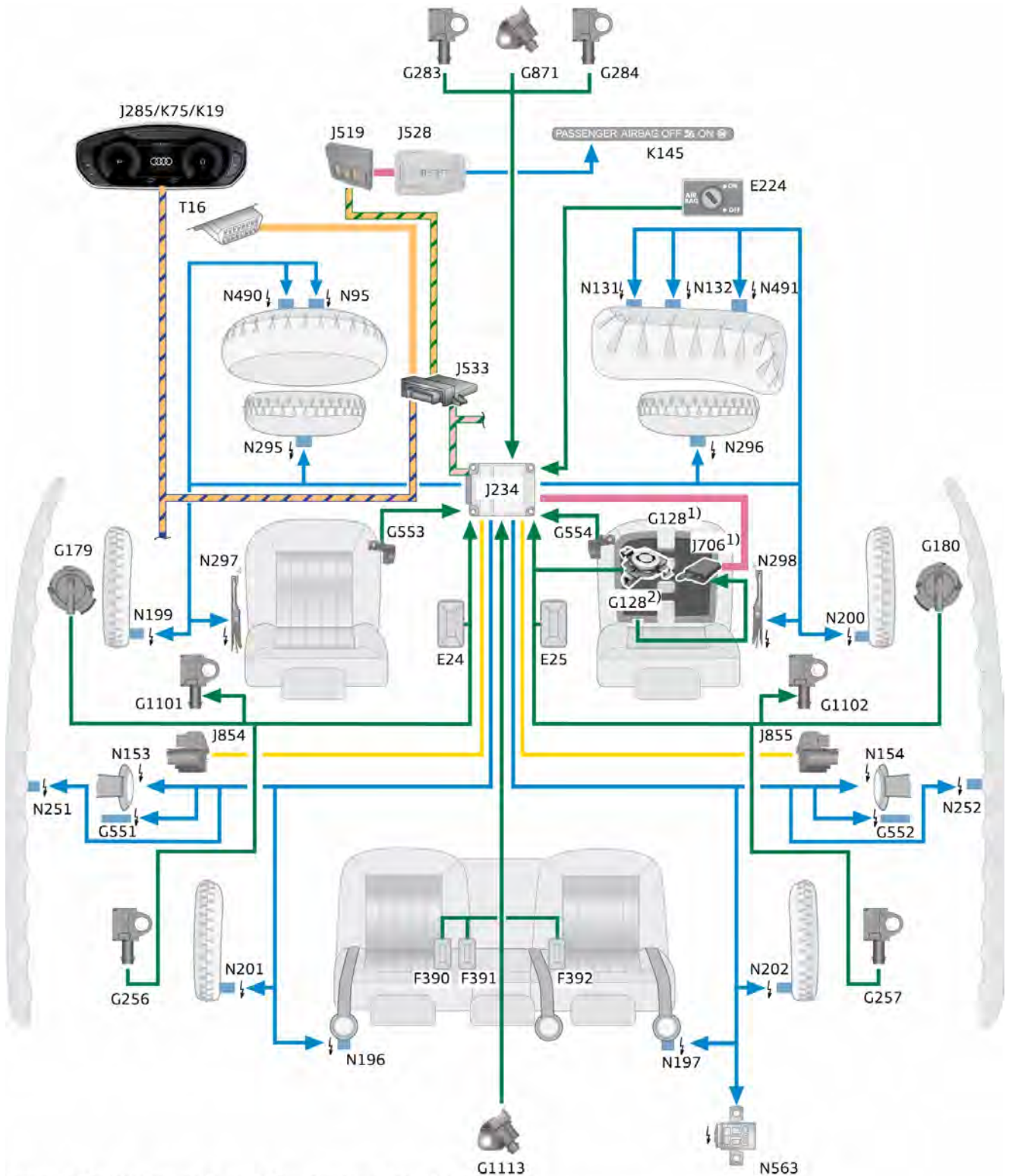

Connection for seat occupied sensor on front passenger side G128

The connection for the seat occupied sensor on front passenger side G128 varies depending on the market version.

¹⁾ In vehicles for the North American region (NAR):

The seat occupied sensor on front passenger side G128 is connected to the seat occupied recognition control unit J706 via a discrete wire. The control unit communicates with the airbag control unit J234 via a LIN bus wire.

²⁾ In vehicles for rest of world (ROW):

The seat occupied sensor on front passenger side G128 is connected directly to the airbag control unit J234 via a discrete wire. A seat occupied recognition control unit J706 is not fitted.

684_041









The system overview shows the components for all markets. Keep in mind that this constellation is not possible in a production model.

Additional equipment

Equipment may vary due to different requirements and country-specific regulations.

Key:

E24	Driver side belt switch
E25	Front passenger side belt switch
E224	Key operated switch to deactivate airbag on front passenger side
F390	Belt switch for seat row 2, driver side
F391	Belt switch for seat row 2, middle
F392	Belt switch for seat row 2, passenger side
G128	Seat occupied sensor on front passenger side
G179	Side airbag crash sensor on driver side
G180	Side airbag crash sensor on front passenger side
G256	Rear side airbag crash sensor on driver side
G257	Rear side airbag crash sensor on passenger side
G283	Front airbag crash sensor for driver side
G284	Front airbag crash sensor for front passenger side
G551	Driver side belt force limiter
G552	Front passenger side belt force limiter
G553	Driver side seat position sensor
G554	Front passenger side seat position sensor
G871	Crash sensor for power and control electronics
G1101	Crash sensor for side airbag in B-pillar, driver side
G1102	Crash sensor for side airbag in B-pillar, passenger side
G1113	Crash sensor 2 for power and control electronics
J234	Airbag control unit
J285	Control unit in dash panel insert
J519	Onboard supply control unit
J528	Roof electronics control unit
J533	Data bus diagnostic interface (gateway)
J706	Seat occupied recognition control unit
J854	Control unit for front left belt tensioner
J855	Control unit for front right belt tensioner
K19	Seat belt warning system warning lamp
K75	Airbag warning lamp
K145	Warning lamp for airbag deactivated on front passenger side (both ON and OFF status of passenger airbag is indicated)
N95	Airbag igniter on driver side
N131	Airbag igniter 1 on front passenger side
N132	Airbag igniter 2 on front passenger side
N153	Driver seat belt tensioner igniter 1
N154	Front passenger seat belt tensioner igniter 1
N196	Rear belt tensioner igniter on driver side
N197	Rear belt tensioner igniter on passenger side
N199	Side airbag igniter on driver side
N200	Side airbag igniter on front passenger side
N201	Rear side airbag igniter on driver side
N202	Rear side airbag igniter on passenger side
N251	Driver side curtain airbag igniter
N252	Front passenger side curtain airbag igniter
N295	Driver side knee airbag igniter
N296	Front passenger side knee airbag igniter
N297	Igniter for driver side seat belt tensioner 2
N298	Igniter for front passenger side seat belt tensioner 2

N490	Igniter for exhaust valve for driver airbag
N491	Igniter for exhaust valve for front passenger airbag
N563	High-voltage battery isolation igniter
T16	16-pin connector, diagnostic connection
	Diagnostics CAN
	Dash panel insert CAN
	Sub-bus system
	FlexRay
	LIN bus
	Convenience CAN 2
	Input signal
	Output signal

Airbag control unit J234

Crash signal

Airbag control unit J234 registers a collision based on the information supplied by internal and external crash sensors. The airbag control unit classifies a collision as “minor” or “severe” depending on the severity of the collision. A minor collision is further subdivided into multiple crash levels depending on the severity. A severe collision is registered if restraint systems, such as seat belt tensioners and airbags, are deployed. The airbag control unit sends information on the severity of the collision (including the crash levels) to the data bus. Other bus nodes receive these crash signals and can then take various types of action, e.g. turn on the interior lighting.

Airbag control unit J234



684_182

Reaction of high-voltage battery to crash signals

When the airbag control unit detects a collision which meets the relevant criteria, the high-voltage battery is isolated for safety reasons. In the event of a collision, the airbag control unit sends collision signals to the data bus. The gateway (data bus diagnostic interface J533) relays the signal to the battery regulation control unit J840.

Minor collision

In the event of a minor collision with a corresponding crash level, battery regulation control unit J840 isolates the high-voltage battery. If the high-voltage battery has been isolated due to a minor collision, it can be reactivated by resetting terminal 15.

Severe collision

In the event of a severe collision, the signal to isolate the high-voltage battery is transmitted by two different pathways. This helps ensure signal transmission via a redundant (doubled) design.

- › **Pathway 1:**
As in the event of a minor collision with a corresponding crash level, battery regulation control unit J840 isolates the high-voltage battery.
- › **Pathway 2:**

Airbag control unit J234 is connected to high-voltage battery isolator igniter N563 by a discrete wire. The igniter is installed in switching unit for high-voltage battery SX6. The igniter and the switching unit are combined as one unit. Although the name might suggest otherwise, high-voltage battery isolation igniter N563 does not have any pyrotechnic charge. In the event of a severe collision, the airbag control unit sends a current of around 1.75 A to 2 A to the igniter (switching unit). The switching unit evaluates the signals (current) and triggers the isolation of the high-voltage battery by opening the power contactor. If the high-voltage battery has been isolated due to a severe collision, it cannot be activated by resetting terminal 15. In the event of a severe collision, the high-voltage battery must be classified using Guided Fault Finding. If the high-voltage battery is classified as OK, the igniter and therefore the switching unit do not need to be renewed due to the electronic isolation.

Switching unit for high-voltage battery SX6 with high-voltage battery isolation igniter N563



684_301



Reference

Further information on the high-voltage battery (refer to article “High-voltage battery AX2”).

Sensors

Crash sensors

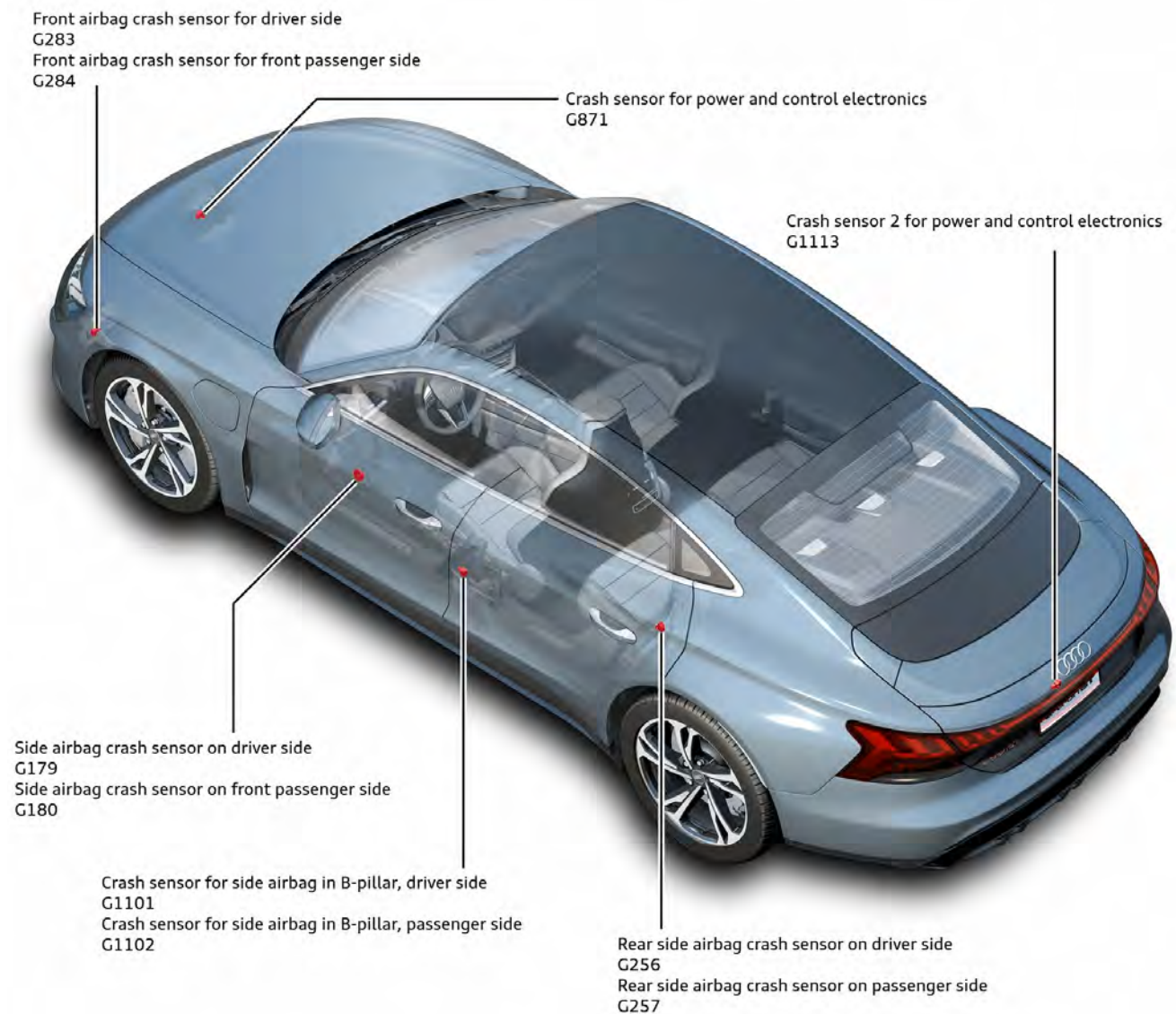

684_184

In order to detect collisions, the Audi e-tron GT (type F8) is equipped with 10 external crash sensors. In addition, airbag control unit J234 contains further internal crash sensors. Unlike the external crash sensors, the internal crash sensors in the airbag control unit cannot be renewed separately.

- › Side airbag crash sensor on driver side G179
- › Side airbag crash sensor on front passenger side G180
- › Rear side airbag crash sensor on driver side G256
- › Rear side airbag crash sensor on passenger side G257
- › Front airbag crash sensor for driver side G283
- › Front airbag crash sensor for front passenger side G284
- › Crash sensor for power and control electronics G871
- › Crash sensor for side airbag in B-pillar, driver side G1101
- › Crash sensor for side airbag in B-pillar, passenger side G1102
- › Crash sensor 2 for power and control electronics G1113

Active safety

Audi pre sense

Depending on the vehicle equipment, the Audi e-tron GT may feature the following Audi pre sense functions:

- > Audi pre sense basic PR no.: 7W1
- > Audi pre sense front PR no.: 6K8
- > Audi pre sense rear including pre sense basic PR no.: 7W3
- > Audi pre sense turn-off assist PR no.: 8T2/8T6
- > Audi pre sense swerve assist PR no.: 8T2/8T6

Fitting locations of sensors for Audi pre sense front, pre sense rear, turn-off assist and swerve assist:

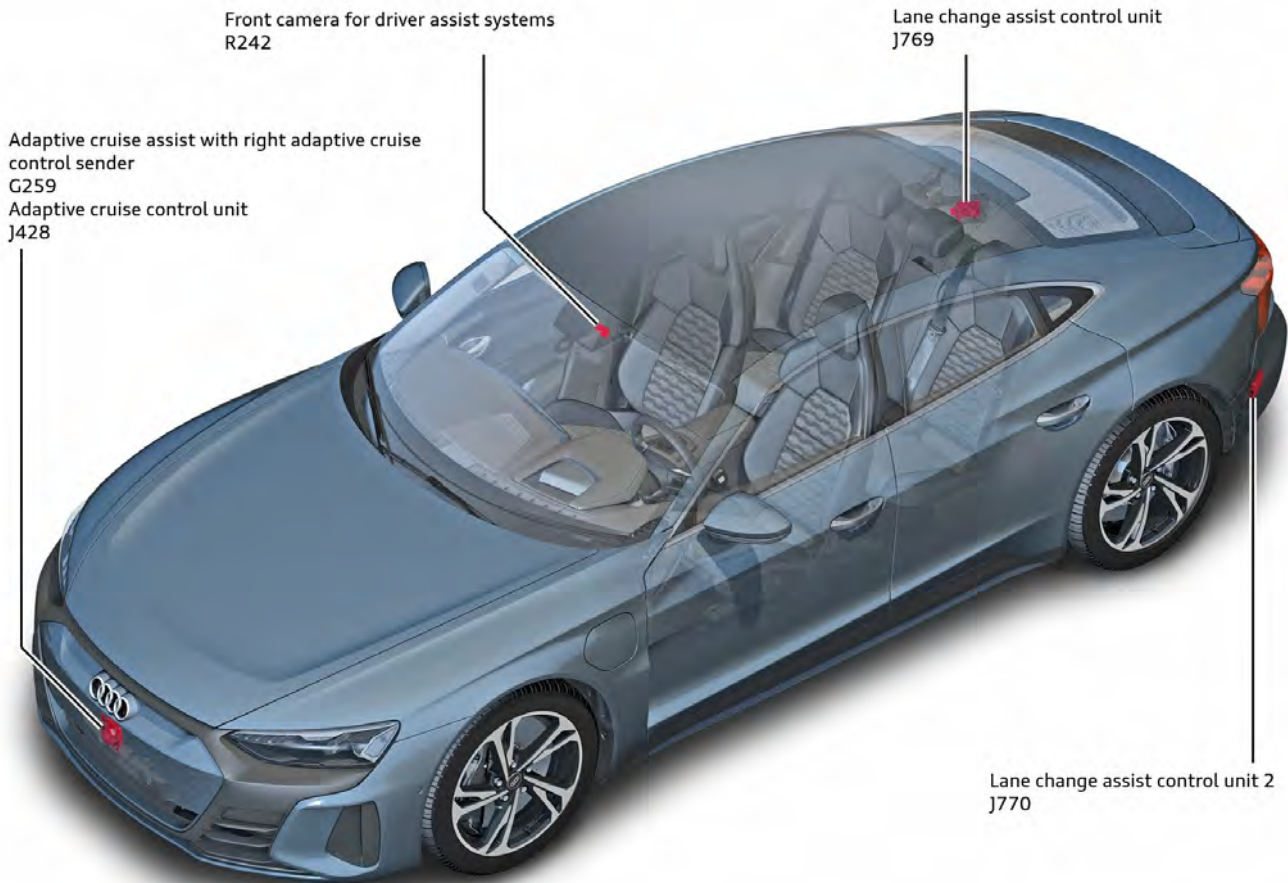

684_238

With regard to Audi pre sense, the Audi e-tron GT (type F8) is based on the Audi A8 (type 4N). The components and specifications have of course been adapted to suit the Audi e-tron GT (type F8). The following changes have been made to Audi pre sense on the Audi e-tron GT (type F8) compared to the Audi A8 (type 4N):

- > On the Audi e-tron GT (type F8), the Audi pre sense swerve assist triggers braking on individual wheels.
- > On the Audi e-tron GT (type F8), the sensor data from front camera for driver assist systems R242, adaptive cruise assist with right adaptive cruise control sender G259 and adaptive cruise control unit J428 are evaluated for Audi pre sense swerve assist and turn-off assist.



Reference

For further information on airbag control unit J234 and Audi pre sense, please refer to SSP 662 “Audi A8 (type 4N)” (refer to article “Active safety”).

Infotainment and Audi connect

Introduction and overview of versions

The Audi e-tron GT features the third generation of the modular infotainment matrix infotainment system, MIB3 for short. The high-end MMI navigation plus is the only version available. The technology that it uses is based on the premium version of MIB3.

Depending on the country, the Audi e-tron GT allows certain features to be activated at a later date via functions on demand. Please refer to the current functions on demand portfolio for the available options.

The MMI navigation plus system is equipped with the following connect services as standard (may vary from country to country):

- › Audi connect emergency call & service including vehicle control services (IW3)
- › Audi connect infotainment plus (IT3)

The vehicle-specific services (IW3) have a licence period of 10 years.

The infotainment services (IT3), which are designed primarily for the customer's comfort, generally have a licence period of 3 years.

The user can check which services belong to the two categories and when the licences expire in the MMI.



Reference

For more information on the MIB3 system, refer to SSP 679 "Third-generation modular infotainment matrix".

MMI navigation plus (7UG)

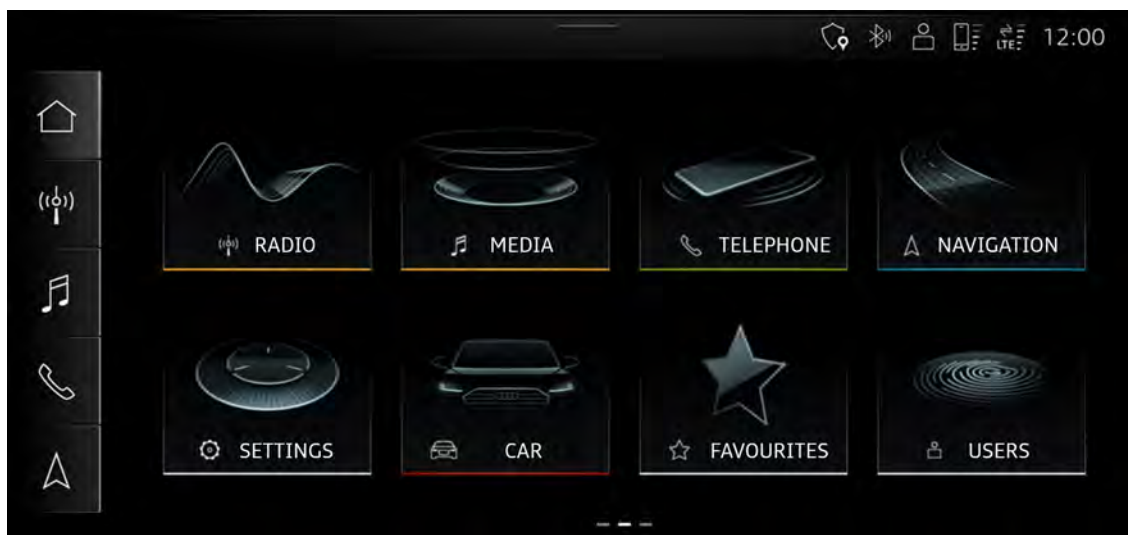

The infotainment system on the Audi e-tron GT has the following features:

10.1" MMI touch display with 1540 x 720 pixels

Audi virtual cockpit plus, 12.3" (9S9)

3D navigation system on SSD (7UG)

FM radio

DAB digital radio or satellite radio for North America (Sirius XM) (QV3)^[10]

Connected radio (Internet radio)

HD radio for North America

Audi smartphone interface (IU1)

2x USB-C sockets in rear (UF8)^[11]

Audi sound system (9VD)

Bluetooth interface (9ZX)

Audi connect emergency call & service including vehicle control services (IW3)^[10]

Audi connect infotainment plus (IT3)^[12]

[10] Standard equipment, depending on country

[11] At market launch, the USB-C sockets in the rear can be used for data transfer and charging. At a later time, they will only be usable as charging connections.

[12] Audi connect plus services (IT3) always includes the Audi connect basic services (IT4).

MMI navigation plus (7UG)

Optional equipment

Audi phone box including wireless charging (9ZE)^[13]

Audi phone box light (for wireless charging only) (9ZV)^[13]

Bang & Olufsen Premium Sound System with 3D sound (9VS)^[14]

Sound

The Audi e-tron GT (type F8) is fitted with the Audi sound system (9VD) as standard. The customer can order the Bang & Olufsen Premium Sound System with 3D sound (9VS) as optional equipment.

Audi sound system (9VD)

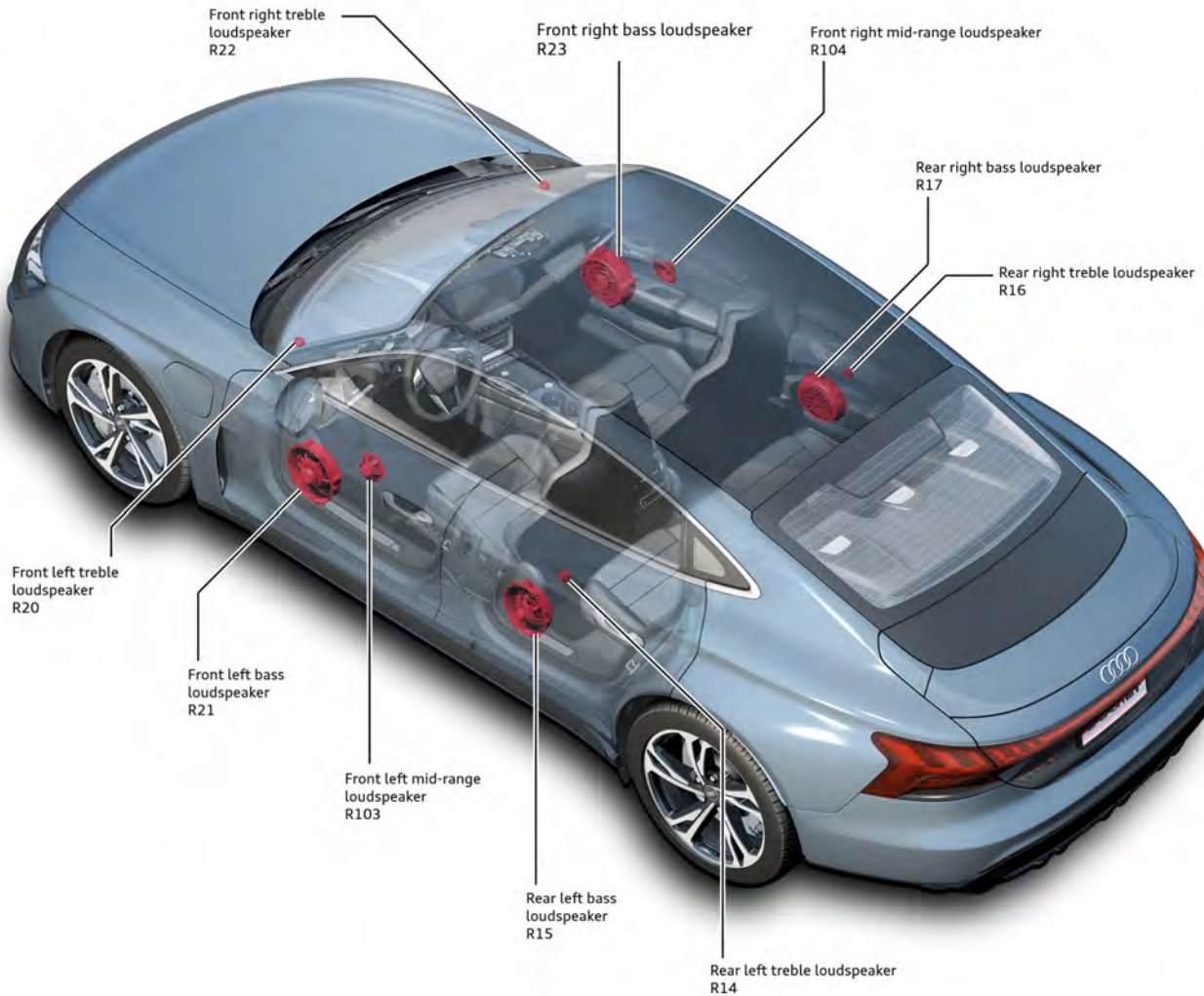

684_115

The Audi sound system has a total of ten loudspeakers: four treble loudspeakers (two in the dash panel and two in the rear doors), two mid-range loudspeakers (in the front doors) and four bass loudspeakers (two in the front doors and two in the rear doors). The Audi sound system achieves an output of 150 W. All of the loudspeakers are actuated by the infotainment control unit (J794).

[13] If an Audi phone box is fitted, two smartphones can be connected via handsfree profile at the same time using the Bluetooth interface.

[14] The Bang & Olufsen Premium Sound System with 3D sound (9VS) is standard equipment on the RS model.

Bang & Olufsen Premium Sound System with 3D sound (9VS)

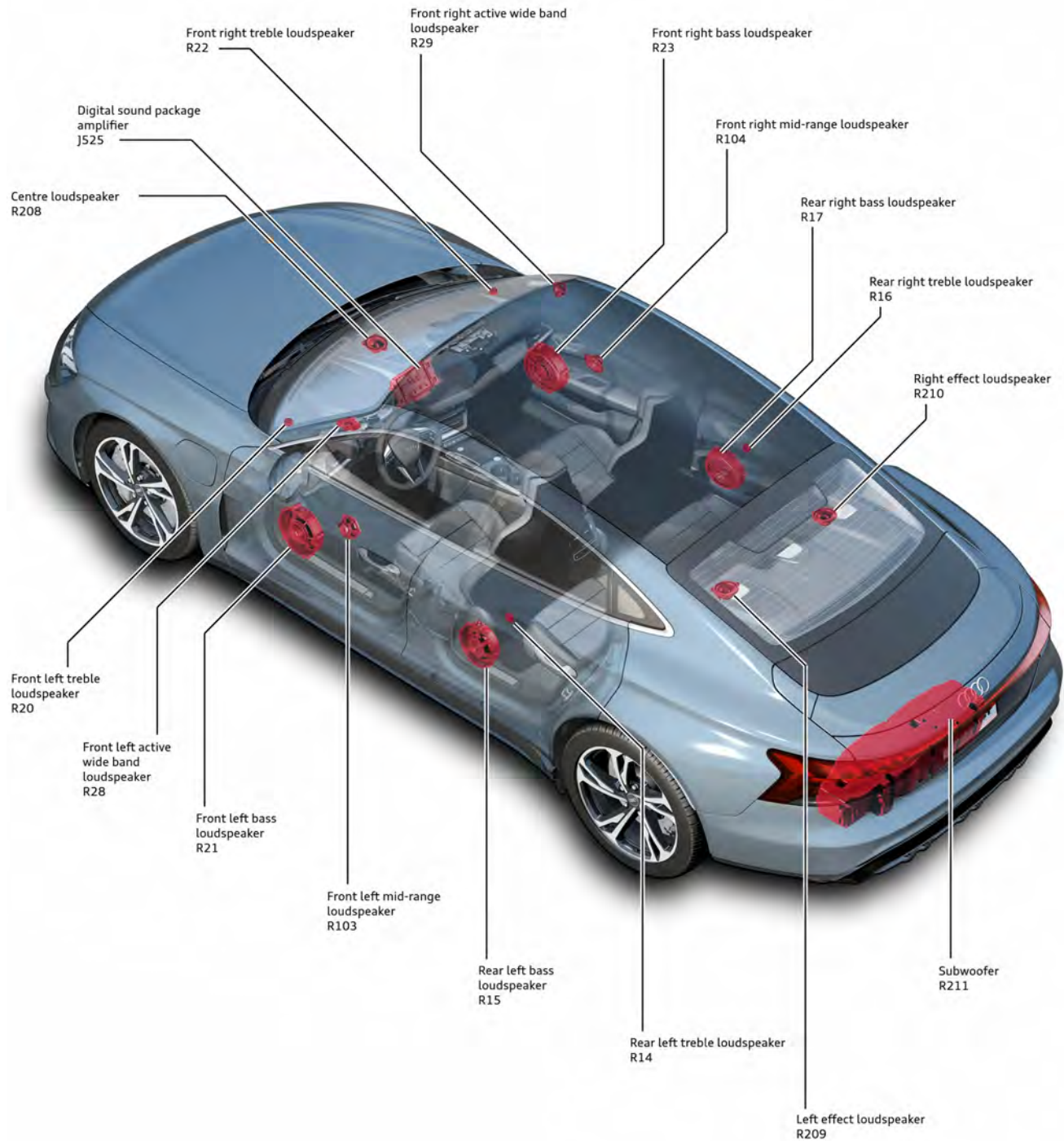

684_072

The optional Bang & Olufsen Premium Sound System with 3D sound offers customers the best sound experience with its 16 loudspeakers and 710 W.

On this sound system, the loudspeakers are actuated by two different control units: some of them are actuated by control unit 1 for information electronics J794, while the rest are actuated by digital sound package control unit J525.

The loudspeakers are actuated according to the following plan:

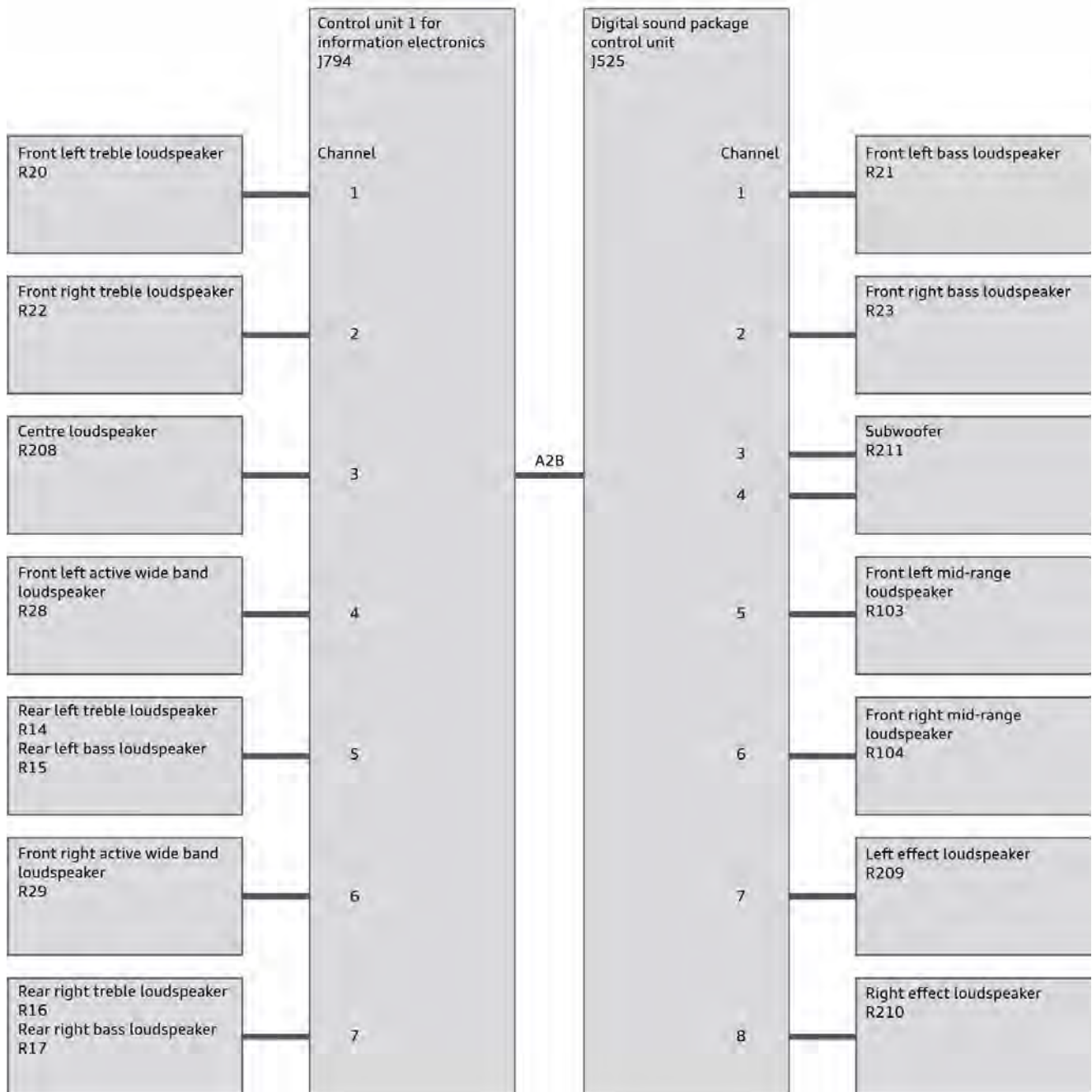

684_110



Reference

For further information related to sound, please refer to SSP 679 “Third-generation modular infotainment matrix” (refer to article “Sound”).

Antennas

Radio antennas

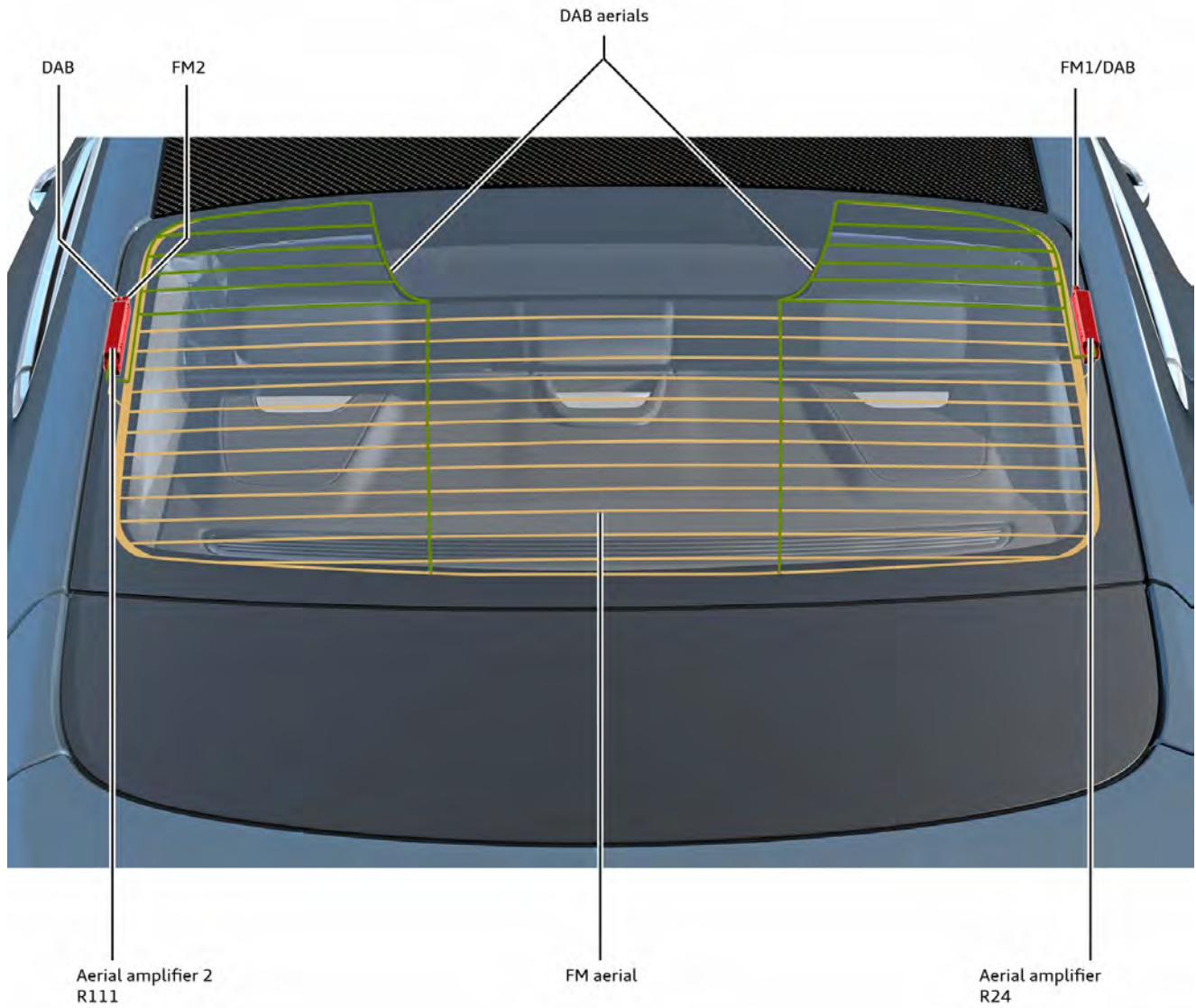

684_071

The Audi e-tron GT (type F8) is designed to receive FM and DAB radio (9VD). The relevant antennas are located in the rear window. On vehicles for the North American market, the SDARS antenna is integrated in the rear lid.

Overview of mobile communication antennas

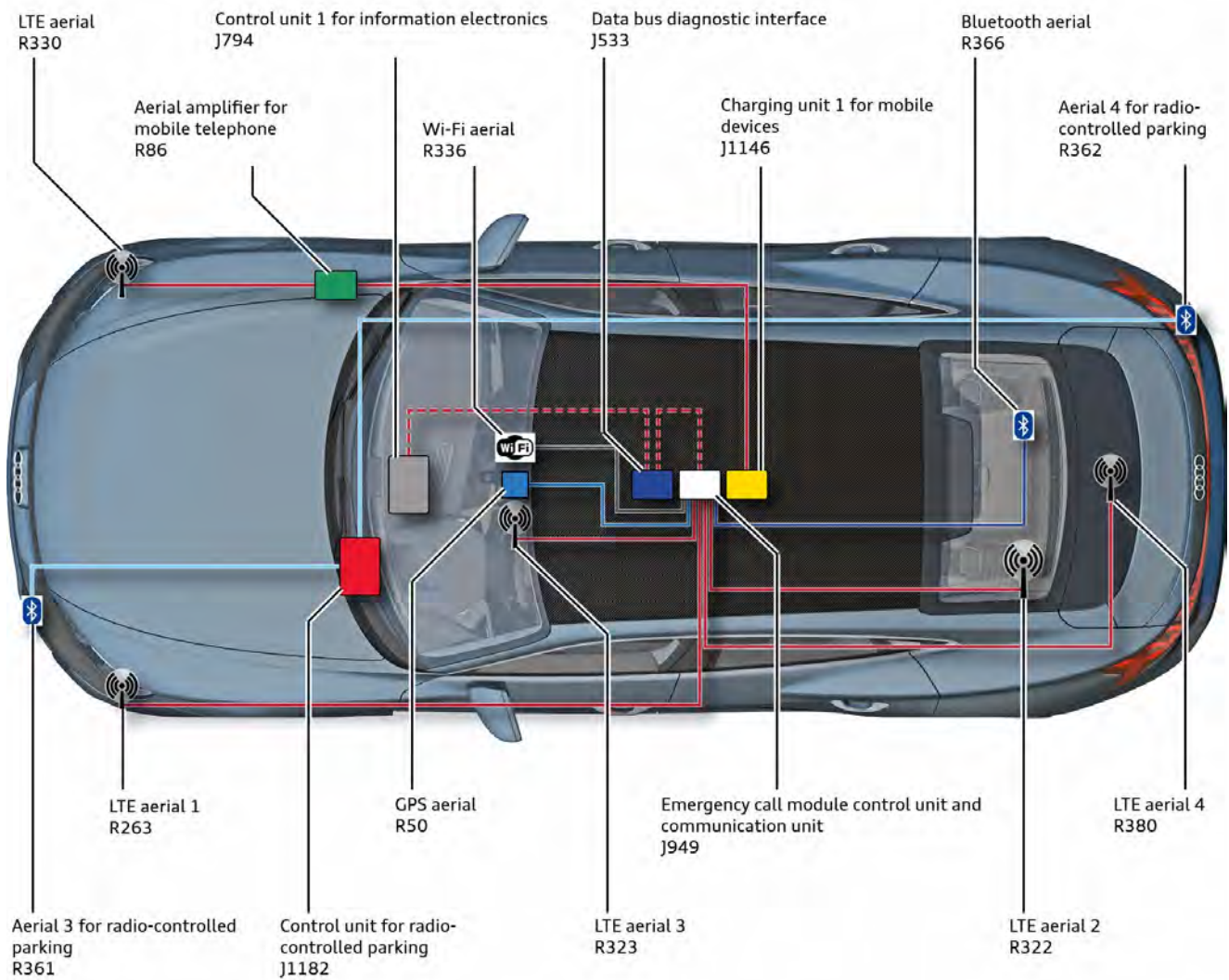

684_163

Wi-Fi and Bluetooth aerials

The vehicle is fitted with a Wi-Fi antenna (wireless data transfer antenna R336) and a Bluetooth antenna (wireless data transfer antenna 2 R366) to enable the customer to pair external devices. The Wi-Fi antenna is located in the mirror base and the Bluetooth antenna is located under the rear shelf (right-side). Both antennas are connected to emergency call module control unit and communication unit J949 (connectivity box).

GPS aerial

The GPS antenna is located in the mirror base and is connected to J949, which calculates the vehicle's position. This information is then transferred via Ethernet to infotainment control unit J794, which performs all navigation functions.

Mobile phone aerials

In addition to the Wi-Fi and GPS antennas, one of the four LTE antennas is also located in the mirror base. The other three LTE antennas are located in the front bumper (left-side), under the rear shelf (left-side) and in the rear lid under the glass trim. The LTE antenna under the rear shelf is the main antenna. The four antennas are connected to the connectivity box. The signal from the main antenna, combined with the signal from the LTE antenna with the best reception, is transmitted to the connected gateway (J533)/the infotainment control unit (J794) via Ethernet in order for the Audi connect services to be performed.

The Audi e-tron GT (type F8) can be fitted with the Audi phone box (charging unit 1 for mobile devices J1146) as optional equipment. Thanks to its connection to the external LTE antenna R330 (in the front bumper, right-side), the Audi phone box improves reception quality while reducing the amount of radio waves from the smartphone inside it that enter the passenger compartment.

Bluetooth Low Energy antennas

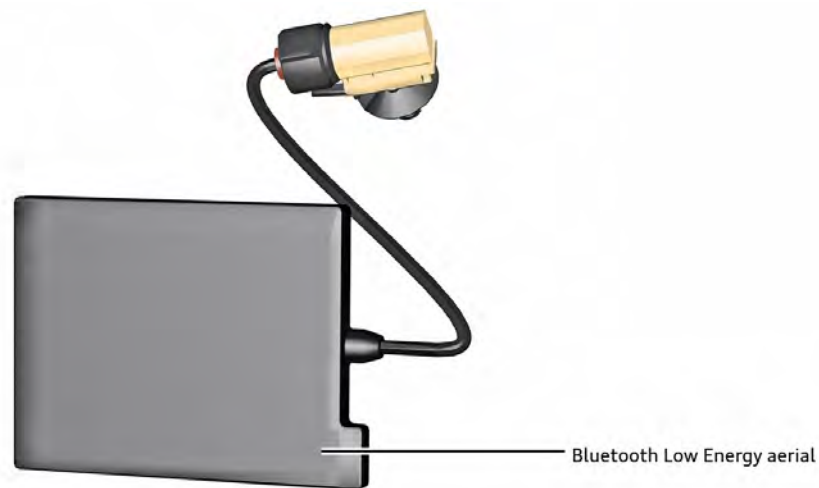

684_293

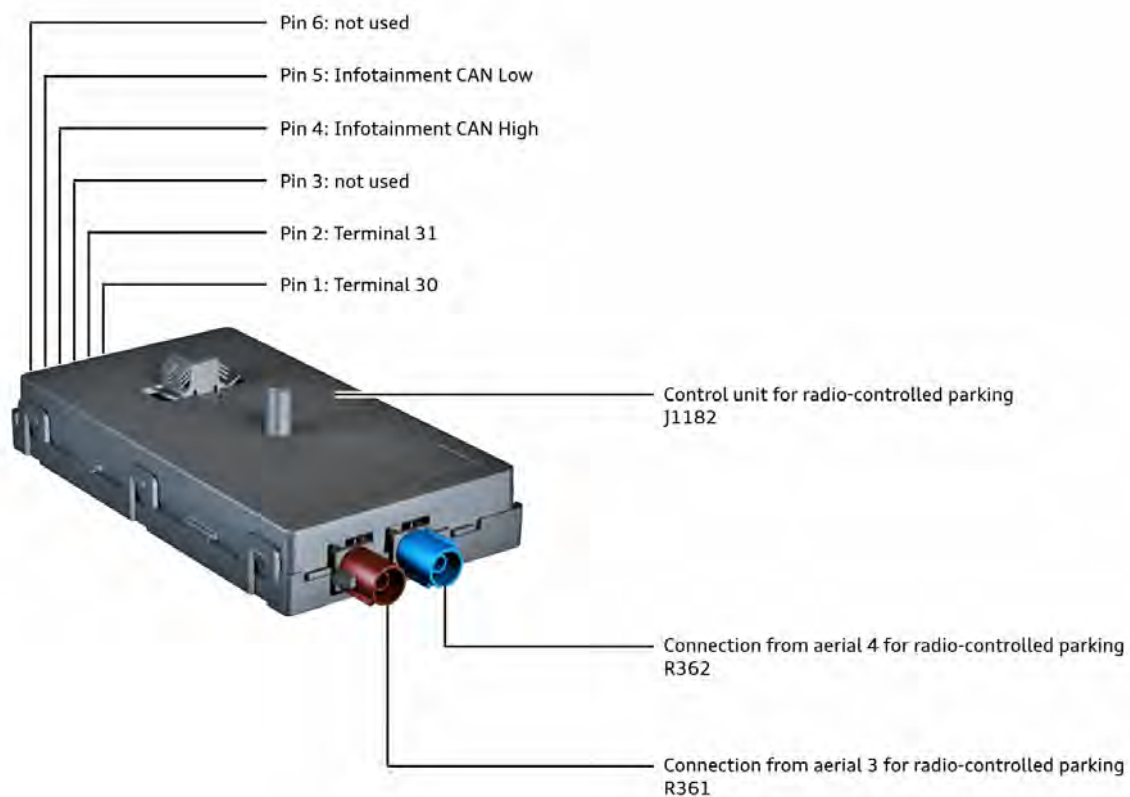

684_224

Two additional Bluetooth antennas are fitted in the bumpers, one at the front left and the other at the rear right. These two antennas support the energy-saving Bluetooth Low Energy technology (BLE) and are responsible for the remote park assist plus. This duplication ensures the best possible coverage of the area around the vehicle.

The BLE technology is fundamentally different from the Bluetooth technology that is used, for example, for HFP or A2DP. The BLE technology that is supported is version 5.0.

The two antennas are connected to control unit for radio-controlled parking J1182, which is located in the driver's footwell below the dash panel. Control unit J1182 reads and evaluates the information that it receives from the two antennas. When an authorised smartphone is identified, J1182 transmits the status via CAN bus to driver assist systems control unit J1121 (zFAS), which is responsible for performing the parking maneuver.

Control unit for radio-controlled parking J1182 is not part of the component protection system. Its diagnostic address is "8107 - antenna module".

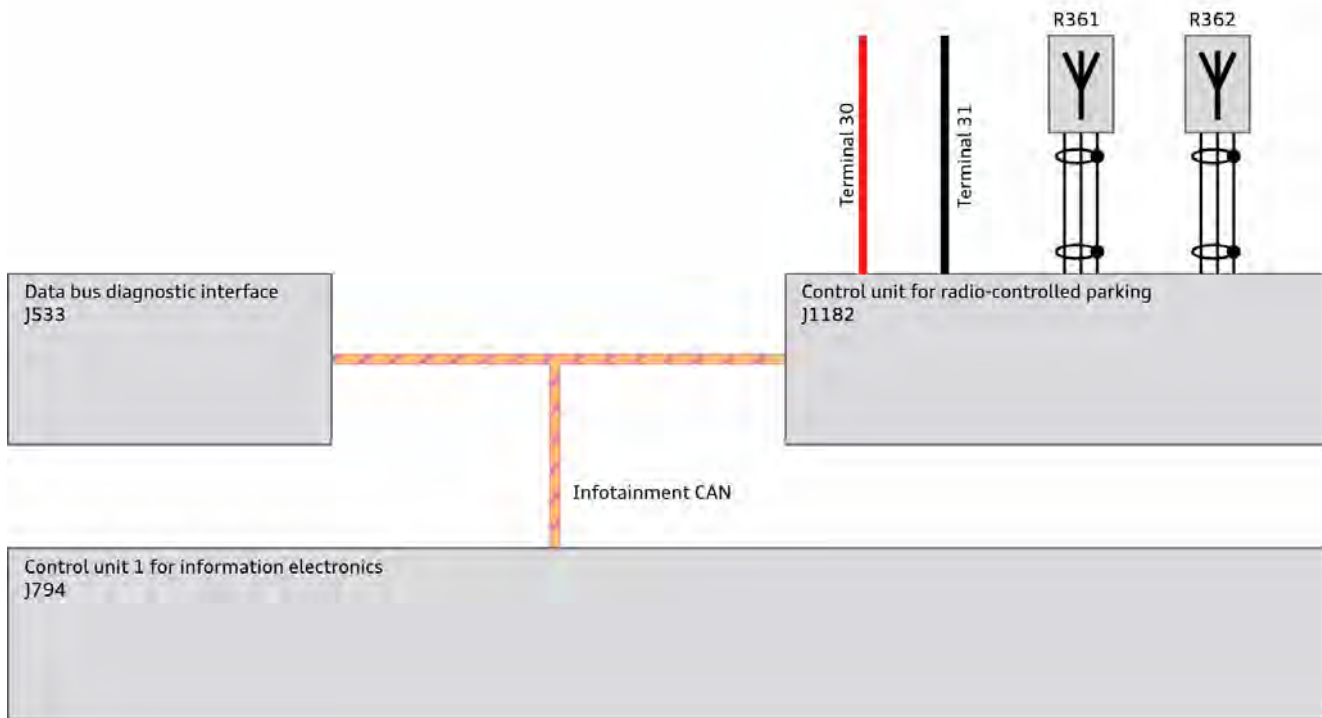

684_326

Key:

- R361** Antenna 3 for radio-controlled parking
- R362** Antenna 4 for radio-controlled parking

Remote park assist plus

The Audi e-tron GT (type F8) is the first Audi model to be fitted with the remote park assist plus. The remote park assist plus enables authorised users to park the vehicle or drive it out of a parking space via the myAudi app without having to sit in the vehicle.

The following requirements must be met in order to pair the smartphone with the vehicle:

- > A key user must have been set in the vehicle
- > The user who wants to use the remote park assist plus must be logged in with his/her myAudi account in the vehicle
- > The user must be logged in with his/her myAudi account in the myAudi app
- > Bluetooth must be activated on the smartphone
- > BLE user identification must be switched on in the myAudi app

As soon as these requirements have been met, the logged in user’s myAudi account calls up the BLE (Bluetooth Low Energy) ID for the vehicle which the vehicle has already sent to the backend.

When the user logs into the myAudi app, the smartphone’s BLE ID is sent to the backend.

If a key user has not been set or if the user has not logged in correctly in the vehicle using his/her myAudi account, the backend sends an error code and the myAudi app displays a corresponding message.

The next time the vehicle is started, the backend sends the smartphone’s BLE ID to the vehicle, thereby completing the Bluetooth pairing for the remote park assist plus.

When using this function, the user must be in the immediate vicinity of the vehicle. If he/she exceeds the maximum distance at any time, the parking maneuver will be interrupted immediately and a corresponding message will be displayed in the myAudi app. To enable the distance between the vehicle and the user to be monitored during the parking maneuver, the user must have the vehicle key (not an Audi connect key) on his/her person.

 **Reference**
Additional information can be found in this SSP (refer to article “Remote park assist plus”).

Servicing, inspection & roadside/breakdown assistance

Service interval display

The following service intervals are displayed:

Mileage-based service intervals and time-based service intervals



684_054

Time-based service intervals



684_271

Depending on the country-specific requirements, the service intervals are displayed either based on mileage and time or on time only **without** a kilometre/mileage limit.

The value displayed in the mileage-based service events field is 30,000 km for new vehicles and is counted down in 100 km blocks. The field for the time-based service event shows the day, month and year that the service is due. Thirty days before the service event is due, the number of days remaining is shown in the instrument cluster and the MMI. The service interval display must be reset using the vehicle diagnostic tester.

Roadside/breakdown assistance

Important notes on

- > safety regulations
- > charging
- > manual release mechanisms
- > warning labels
- > the maintenance connector

can be found in the relevant chapters of this self-study programme and in the Owner's Manual.

Towing/tow-starting

The vehicle must be transported on a breakdown truck (i.e. with all four wheels on the truck) or a special transporter.

The vehicle must not be towed or push-started.



Note

It is not permitted to "miss out" service events. The information provided in the up-to-date service literature applies. Maintenance intervals are displayed when the maintenance tables are created.

Please note that during the delivery inspection and every time after renewing the brake pads, the brakes of the Audi e-tron GT must be "braked in". It is very important that you use the vehicle diagnostic tester to do this.

All rights and technical modifications reserved.

Copyright

AUDI AG

I/VH-53

service.training@audi.de

AUDI AG

D-85045 Ingolstadt

Technical status 02/2021