



---

# SERVICE CAMPAIGN BULLETIN

---

Reference:

NTB13-016

Date:

February 21, 2013

---

## VOLUNTARY SERVICE CAMPAIGN 2011 QUEST TOW HITCH REPLACEMENT

**CAMPAIGN I.D.: PC195**

**APPLIED VEHICLE:** 2011 Quest (E52)

**Check Service COMM to confirm campaign eligibility.**

### INTRODUCTION

Nissan is conducting a Voluntary Service Campaign on certain Model Year 2011 Nissan Quest vehicles equipped with a genuine Nissan accessory tow hitch. These accessory tow hitches were manufactured without drain holes, which may result in corrosion. Certain vehicles, identified in Service COMM, are known to have tow hitches without drain holes and will have the tow hitch replaced at no charge for parts or labor.

### IDENTIFICATION NUMBER

Nissan has assigned identification number **PC195** to this campaign. The correct number must appear on all communications and documentation of any nature dealing with this campaign.

### DEALER RESPONSIBILITY

Dealers are to correct each vehicle falling within the range of this campaign that enters the service department. This includes vehicles purchased from private parties or presented by transient (tourist) owners and vehicles in a dealer's inventory.

## SERVICE PROCEDURE

### Replace Genuine Nissan Accessory Tow Hitch

**NOTE:** For more details on replacement, refer to the 2011 Quest Trailer Tow Hitch Installation Instructions in ASIST located under the **Acc. Install Instructions** tab.

1. Remove the two (2) rear bumper fascia fasteners on each side.

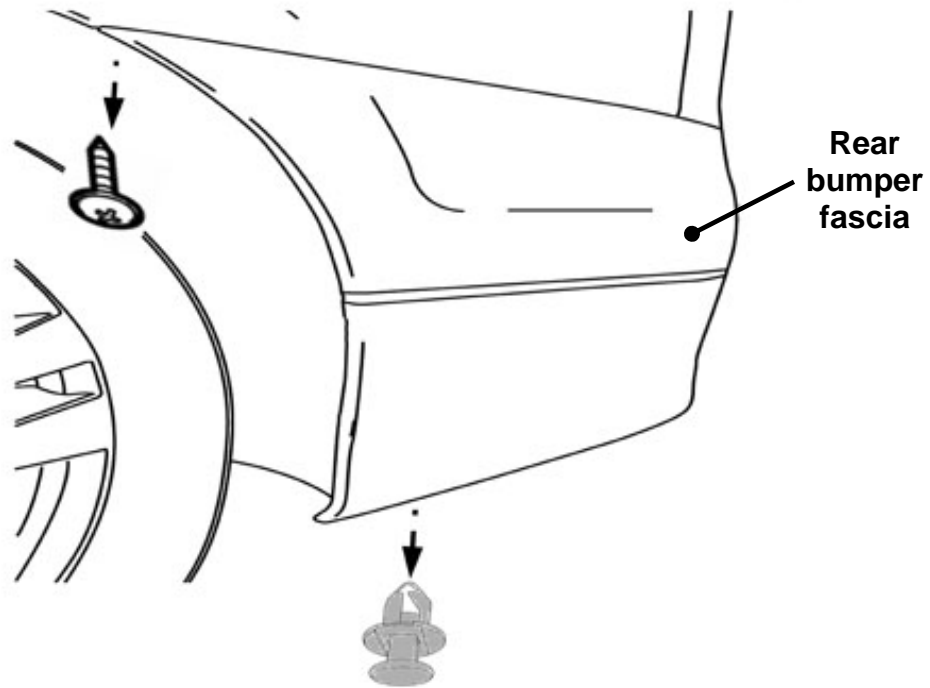

Figure 1

2. Remove the two (2) clips shown in Figure 2.

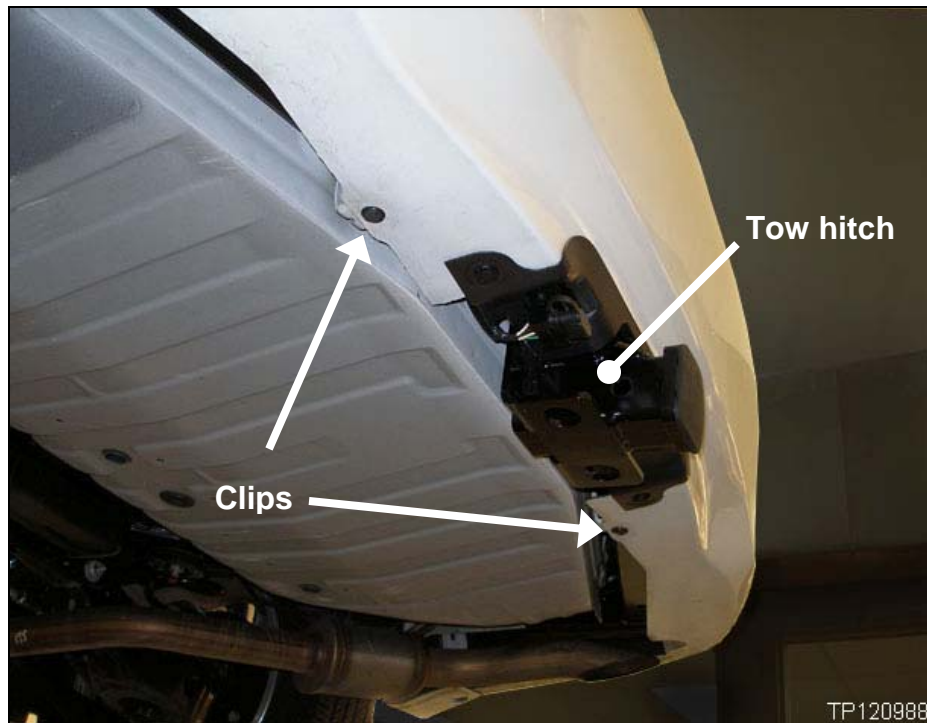

Figure 2

4. Remove the 4-pin connector.

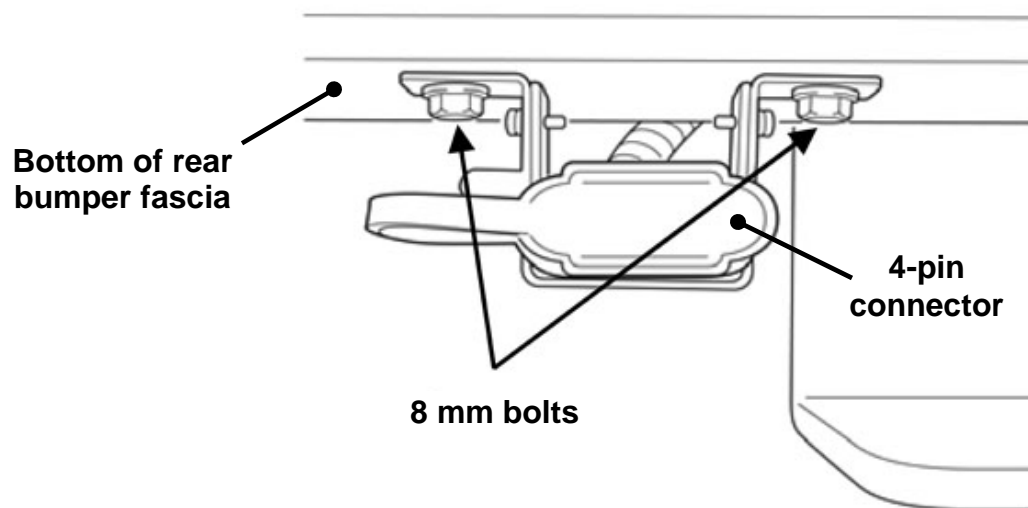

Figure 3

- Carefully unfasten both sides of the rear bumper fascia by pulling outward.



Figure 4

- Carefully remove the rear bumper fascia.

**NOTE:** This is a two-person job.

**CAUTION:** Store the rear bumper fascia in a place where it will stay clean and undamaged.

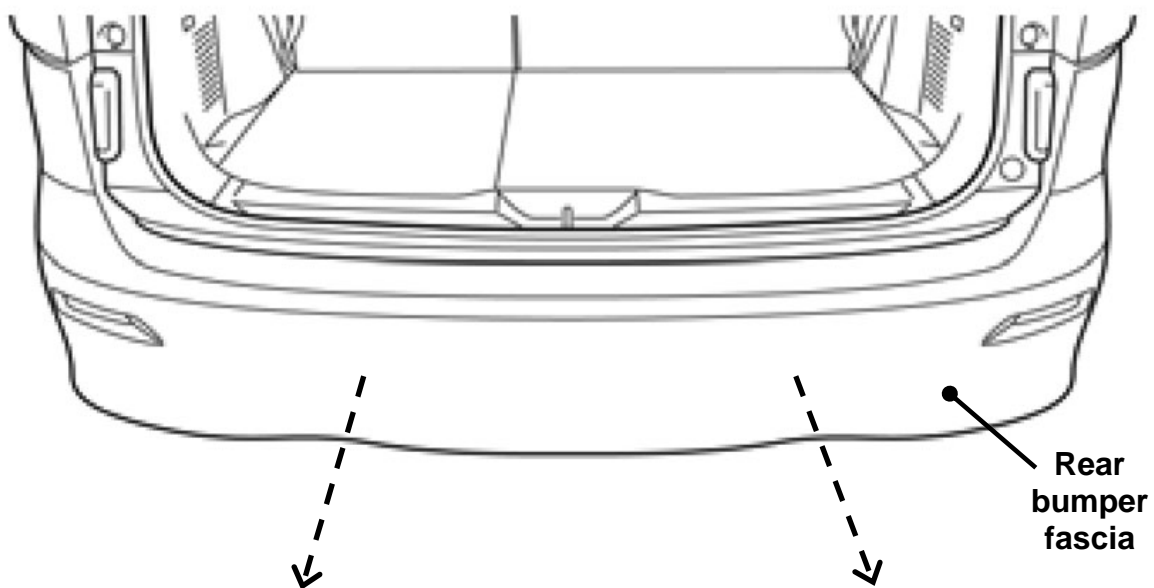

Figure 5

3. Unfasten all nine (9) harness clips from the hitch.

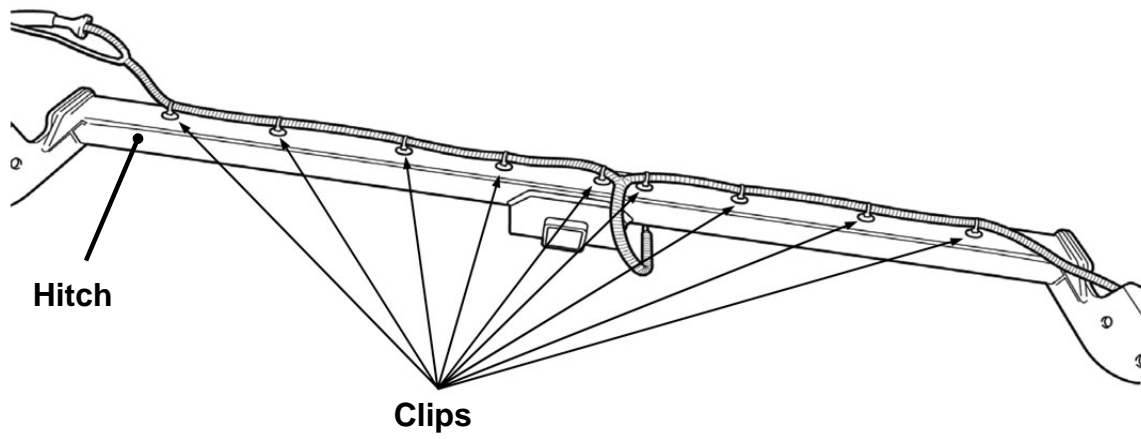

Figure 6

5. Unhook the rear exhaust hanger (for additional clearance).



Figure 7

6. Unbolt the three (3) bolts on each side, and then remove the tow hitch.

**NOTE:** This is a two-person job.

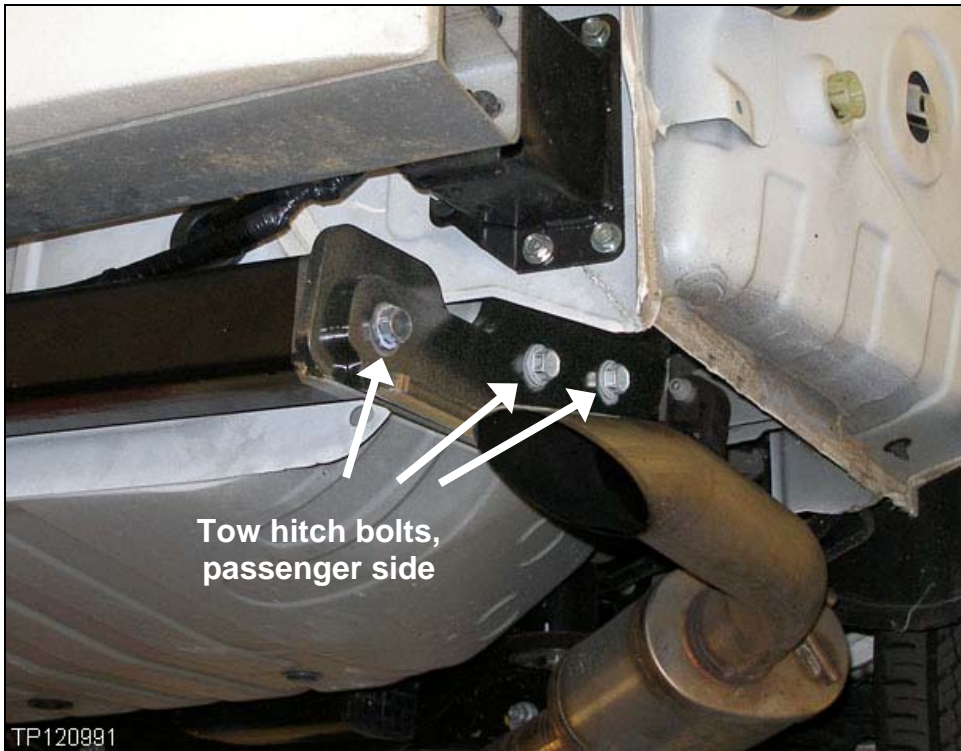

Figure 8

7. Install the new tow hitch in reverse order of removal.

- Tow hitch bolts torque: 110-150 N•m (11.2-15.3 kg-m, **73-96 ft lbs**)
- 4-pin connector bolts torque: 3.9 N•m (0.39 kg-m, **35 in lbs**)

**PARTS INFORMATION**

DESCRIPTION	PART NUMBER	QUANTITY
Quest Tow Hitch	999T5-NW010	1

**CLAIMS INFORMATION**

Submit a Campaign (CM) line claim using the applicable claims coding below:

CAMPAIGN ID #	DESCRIPTION	OP CODE	FRT
PC195	Replace Tow Hitch	PC1950	1.0 hrs

Expense code:

EXPENSE CODE	DESCRIPTION	MAX AMOUNT
502	Car Rental	(1)

(1) Up to \$40.00 a day, 4 day Maximum.

## **OWNER'S LETTER (example of typical owner's letter)**

Dear Nissan Quest Owner:

Nissan is committed to providing the highest levels of product quality and customer satisfaction. We believe that our current and future success depends on your continued satisfaction with Nissan. With that in mind, we want to bring to your attention important information regarding your vehicle.

### **REASON FOR SERVICE CAMPAIGN**

Some potentially affected 2011 Quest vehicles may have been equipped with Tow Hitch Cross Tubes that do not contain drain holes. As a result, water may be prevented from draining properly and potentially cause corrosion. This is not a safety issue, and the vehicle still meets and/or exceeds all applicable safety standards.

### **WHAT NISSAN WILL DO**

Our records indicate that an affected tow hitch may have been installed on your vehicle. If your vehicle does not have a tow hitch installed, there is no action necessary on your part and you may disregard this notice. If a tow hitch is installed, to assure your continued satisfaction and confidence in your vehicle, we ask that you bring your vehicle to your nearest authorized Nissan dealer who will confirm whether your tow hitch lacks drain holes and, if so, will replace the Tow Hitch Assembly at **no charge to you for parts or labor**. The service should take about an hour to complete, but your Nissan dealer may require your vehicle for a longer period of time based upon their work schedule.

### **WHAT YOU SHOULD DO**

Contact your Nissan dealer at your earliest convenience in order to arrange an appointment. **To ensure the least inconvenience for you, it is important that you have an appointment before bringing your vehicle to the Nissan dealer for service.** Please bring this notice with you when you keep your service appointment. Instructions have been sent to your Nissan dealer.

If the dealer fails, or is unable to complete the service free of charge, you may contact the National Consumer Affairs Department, Nissan North America, Inc., P.O. Box 685003, Franklin, TN 37068-5003. The toll free number is 1-800-NISSAN1 (1-800-647-7261).

Thank you for providing us an opportunity to ensure on-going satisfaction with your Nissan vehicle.