

Classification:

RS13-012

Reference:

ITB13-023

Date:

July 3, 2013

2003-2008 FX45/FX35; REVISED FRONT PASSENGER AIR BAG MODULE SERVICE PROCEDURES

APPLIED VEHICLES: 2003-2008 FX45/FX35 (S50)

SERVICE INFORMATION

A change has been made to the Front Passenger Air Bag Module removal and installation procedures in the 2003-2008 FX45/FX35 Electronic Service Manuals.

In the revised procedures, the two front passenger air bag module fixing nuts can be re-used during installation.

NOTE: The front passenger air bag module fixing bolt must be replaced after removal.

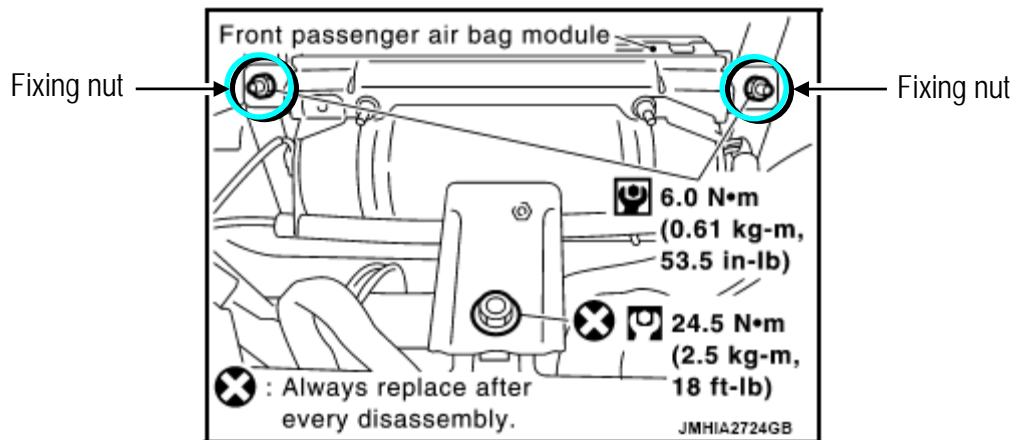

Fixing nuts can be re-used

Please use the updated service information hyperlinked below if you need to service the front passenger air bag module for any reason.

Click → [HERE](#) ← to view the updated Front Passenger Air Bag Module removal and installation procedures.

FRONT PASSENGER AIR BAG MODULE

< SERVICE INFORMATION >

SERVICE INFORMATION

FRONT PASSENGER AIR BAG MODULE

Removal and Installation

INFOID:000000001296063

REMOVAL

CAUTION:

- Before servicing SRS, turn ignition switch OFF, disconnect both battery cables and wait at least 3 minutes.
- Always work from the side of or under front passenger air bag module.
- Do not use air tools or electric tools for servicing.

1. Disconnect front passenger air bag module connector (1).

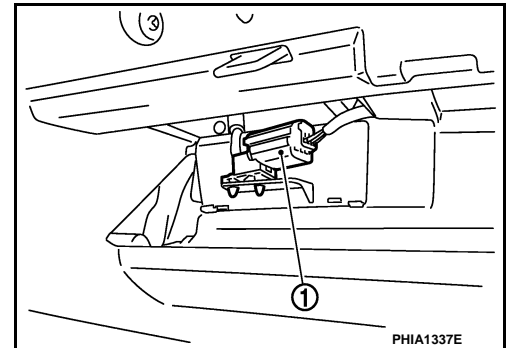

2. Remove glove box assembly and instrument passenger lower panel. Refer to IP, "Instrument Panel Assembly".
3. Remove display control unit, if navigation system is equipped.
4. Remove tire pressure warning control unit, if tire pressure warning control system is equipped.
5. Remove the front passenger air bag module fixing bolt and nuts, and then remove front passenger air bag module.

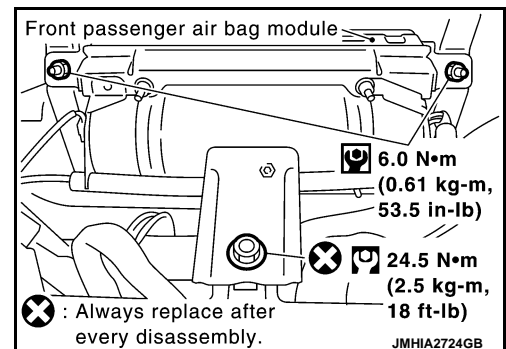

CAUTION:

- Always place front passenger air bag module with caution label side facing upward.
- Do not insert any foreign objects (screwdriver, etc.) into front passenger air bag module.
- Do not disassemble front passenger air bag module.
- Do not use old bolts after removal; replace with new bolts.

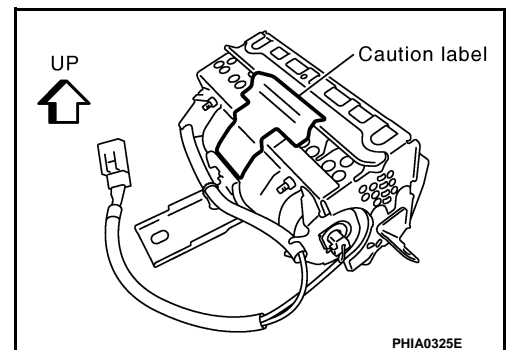

FRONT PASSENGER AIR BAG MODULE

< SERVICE INFORMATION >

- Replace front passenger air bag module if it has been dropped or sustained an impact.
- Do not expose the front passenger air bag module to temperatures exceeding 90°C (194°F).
- Do not allow oil, grease or water to come in contact with the front passenger air bag module.
- After front passenger air bag module inflates, the instrument panel assembly should be replaced.

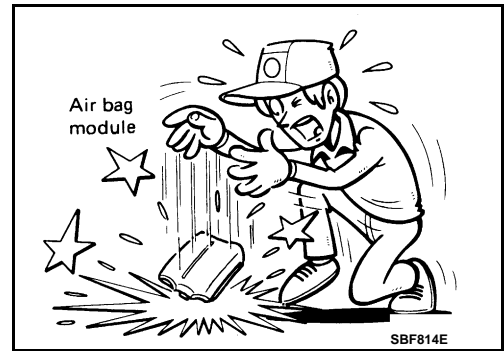

INSTALLATION

Install in the reverse order of removal.

CAUTION:

- Be careful not to damage the harness while installing.
- After the work is completed, make sure no system malfunction is detected by air bag warning lamp.
- In case that malfunction is detected by the air bag warning lamp, reset by the self-diagnosis function and delete the memory by CONSULT-II.
- In case that malfunction is still detected after the above operation, perform self-diagnosis to repair malfunctions. Refer to Refer to SRS, "SRS Operation Check".

A

B

C

D

E

F

G

SRS

I

J

K

L

M

N

O

P