

**Classification:**

BT13-021a

**Reference:**

ITB13-049a

COPYRIGHT© NISSAN NORTH AMERICA, INC.

**Date:**

September 4, 2015

## 2013 JX35 AND 2014-2015 QX60; WEATHERSTRIP ON ROOF SIDE MOLDING COMING LOOSE

This bulletin was amended to change the Service Procedure to include installing self-adhesive foam tape and to include the current model years. Please discard the prior version.

**APPLIED VEHICLE:** 2013 JX35 (L50)  
2014-2015 QX60 (L50)

**IF YOU CONFIRM:**

The rubber weatherstrips on either one of the roof side molding assemblies (moldings) is coming loose from the molding itself.

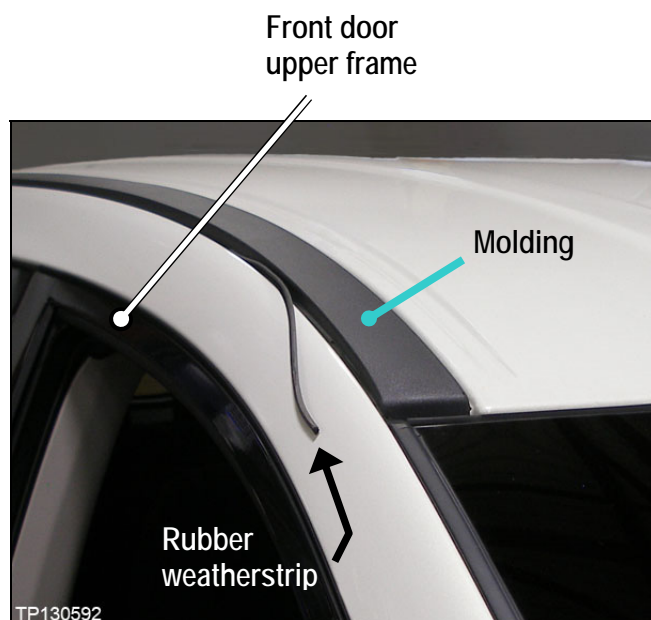

Figure 1

**ACTION:**

Replace **both** left and right moldings with the ones listed in **PARTS INFORMATION**.

- Refer to **SERVICE PROCEDURE** for molding replacement.

**IMPORTANT:** The purpose of **ACTION** (above) is to give you a quick idea of the work you will be performing. You **MUST** closely follow the entire **SERVICE PROCEDURE** as it contains information that is essential to successfully completing this repair.

Infiniti Bulletins are intended for use by qualified technicians, not 'do-it-yourselfers'. Qualified technicians are properly trained individuals who have the equipment, tools, safety instruction, and know-how to do a job properly and safely. **NOTE:** If you believe that a described condition may apply to a particular vehicle, **DO NOT** assume that it does. See your Infiniti dealer to determine if this applies to your vehicle.

## SERVICE PROCEDURE

### NOTES:

- Make sure to replace both moldings, even if only one has a loose weatherstrip.
- The new moldings will need to be painted to match the body color. Have them painted and ready to install before starting this service procedure.

NOTE: Use an appropriate masking technique.

- After the parts have been painted, make sure the adjustable finisher at the rear of the molding moves freely (see page 8, step 4 and Figure 15).

**CAUTION:** Use a fender cover or suitable covering to protect painted surfaces while performing this Service Procedure.

### Remove Roof Side Molding Assemblies

1. **If equipped**, carefully remove both cross bars (they mount transversely over the roof).
  - Each cross bar has a total of four (4) T30 TORX bolts.



Figure 2

2. Remove the moldings:
  - a. Pry up near the front end until the front clip unsnaps.
  - b. Carefully pull up on the loosened front end until all clips unsnap.

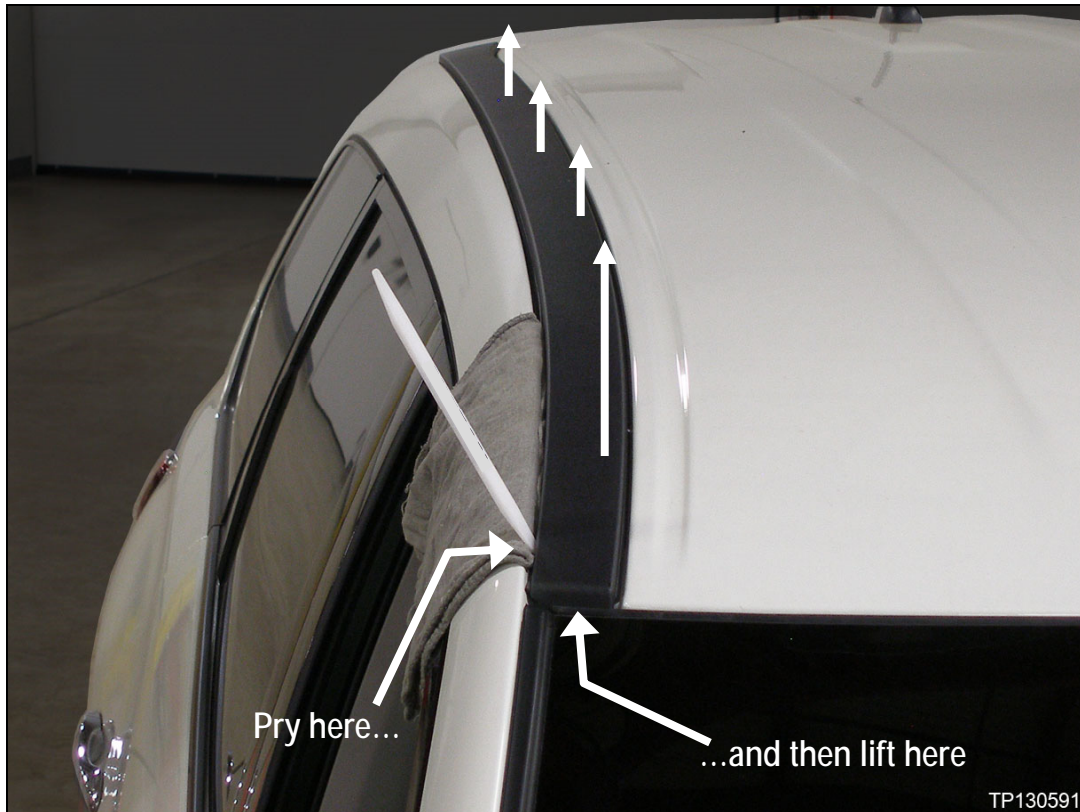

Figure 3

**NOTE:**

- Each molding has nine (9) clips and one (1) hook at the rear.
- The molding shown in Figure 3 is the style that does not accept cross bars.
- The molding style that does accept cross bars is removed in the same way as shown in Figure 3.
- Moldings are one-time use. Do not attempt to reuse them.

3. Cut in half and remove any clips stuck to the plastic rivets with a suitable tool.

**CAUTION:** Protect painted areas with a clean shop rag or suitable covering.

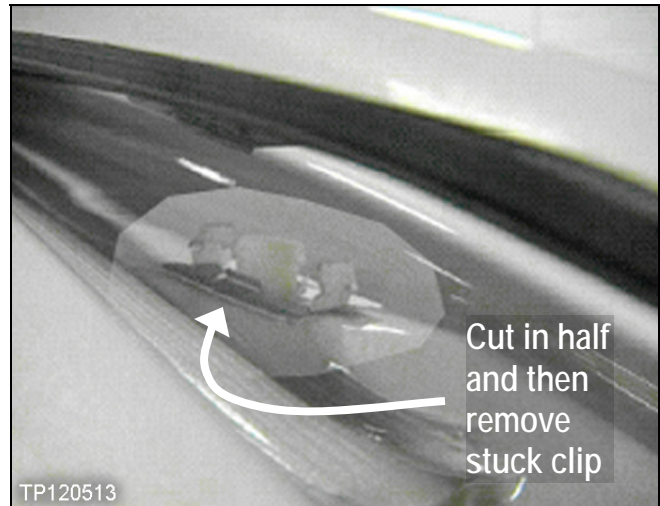

Figure 4

- Cut the clip on both sides (see Figure 5 and 6).

**CAUTION:** Do not pull off the clip from the plastic rivet. Cut the clip in two (2) pieces, and then remove from the plastic rivet.



Figure 5

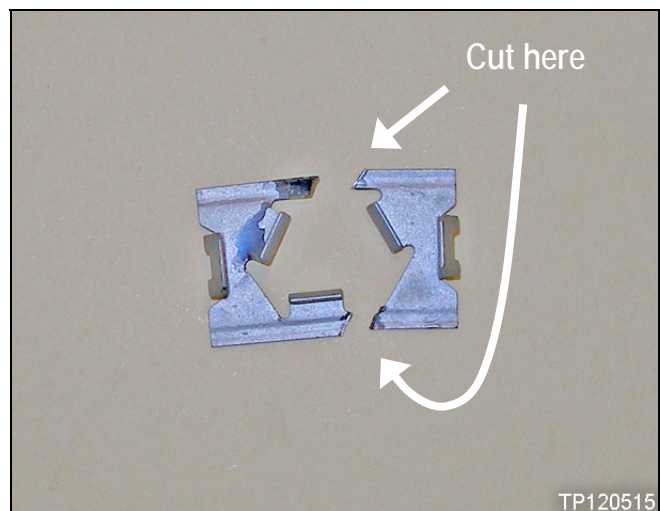

Figure 6

## Install Self Adhesive Foam Tape

**NOTE:** In the following steps the driver's side of the vehicle is shown. The passenger side is similar.

1. Clean the roof area where the molding was removed with 50% isopropyl alcohol.
  - Remove any dust or debris.

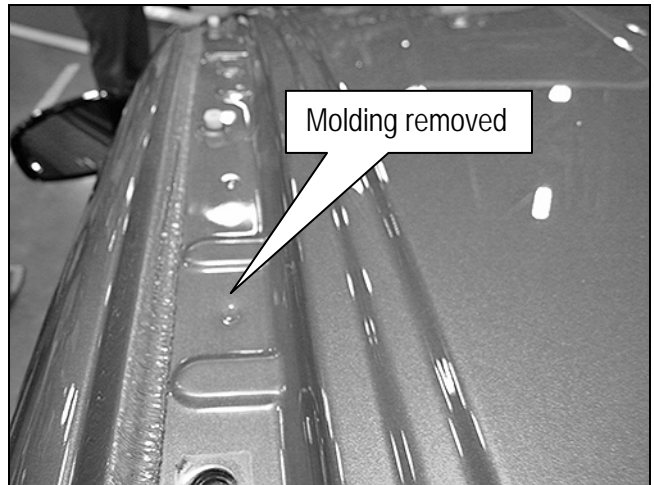

Figure 7

2. Install two strips of self-adhesive foam tape:
  - a. Peel several inches of the adhesive backing from the first foam tape strip.
  - b. Attach several inches of the first foam strip at the corner of the windshield (Figure 8).
    - Tuck the foam tape under the windshield seal.

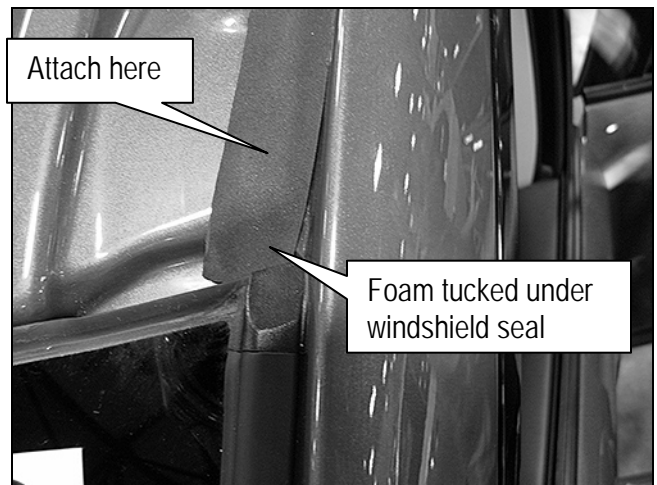

Figure 8

- c. While peeling only enough of the adhesive backing to allow several inches at a time to be attached apply the strip along the outside edge of the molding recess as shown in Figure 9.
    - Apply the strip in as straight a line as possible.

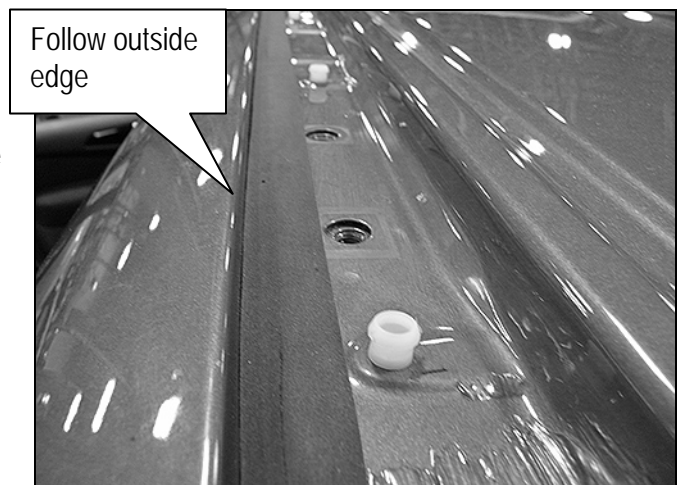

Figure 9



- d. Cut the excess foam tape to approximately the length shown in Figure 10.

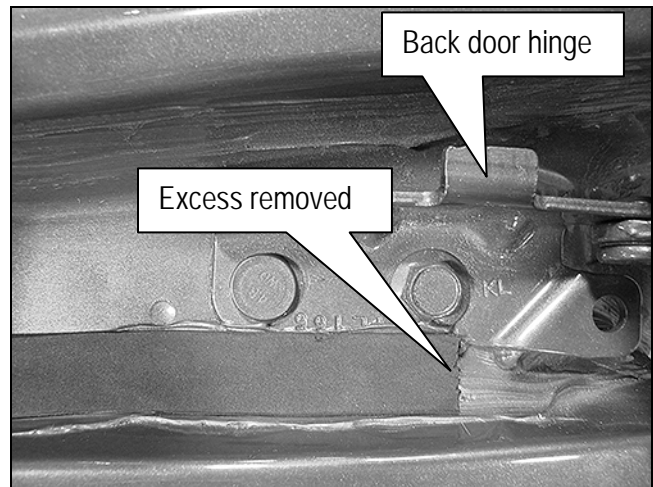
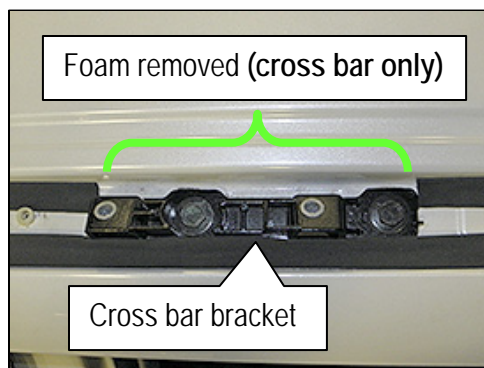

Figure 10

- e. Peel several inches of the adhesive backing from the second foam tape strip.

**NOTE:** for vehicles with cross bar brackets cut foam to bypass brackets on the inside edge.



- f. Attach several inches of the second foam strip along the inside edge (Figure 11).

- Tuck the foam tape under the windshield seal.

- g. While peeling only enough of the adhesive backing to allow several inches at a time to be attached, apply the strip along the inside edge of the molding recess as shown in Figure 11.

- The foam strip should be applied as straight as possible.

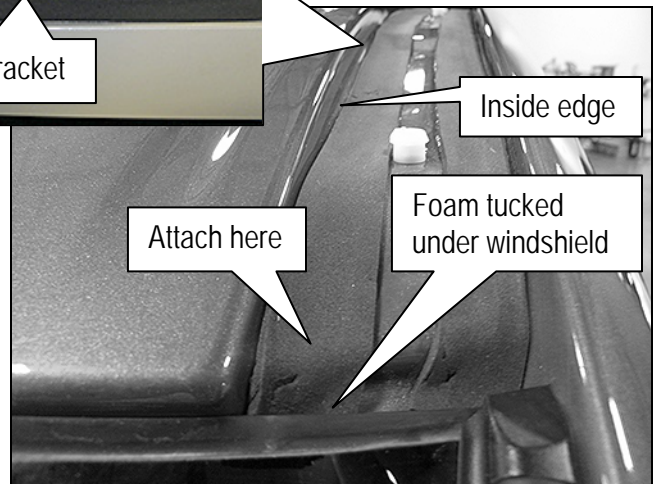

Figure 11

- h. Cut the excess foam tape to approximately the length shown in Figure 12.

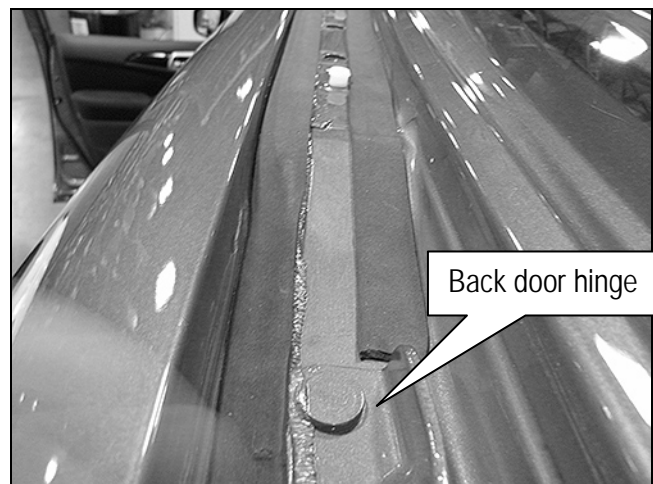

Figure 12

## Install New Roof Side Molding Assemblies

**NOTE:** Before starting, make sure the adjustable finisher at the rear of the molding moves freely (see page 8, Figure 15).

1. **IMPORTANT:** Using your fingers, rotate all plastic rivets 90°.
  - If not able to turn with your fingers, carefully use "needle nose" pliers or equivalent tool.
  - Rotating the plastic rivets will allow the new molding to "grab on" to a different contact spot.

**CAUTION:** The rivets are made of soft plastic. Do not use excessive force.

- It is recommended to draw marks on the body and plastic rivets 90° apart to ensure the plastic rivets are rotated the correct amount.

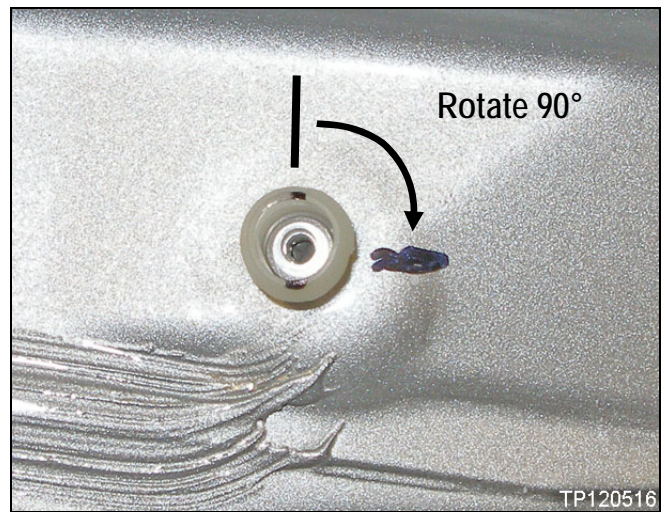

Figure 13

2. Tuck the front end of the new molding (previously painted to match body color) under the windshield seal (see Figure 14).
3. Snap in place the clip closest to the windshield first (see Figure 14).

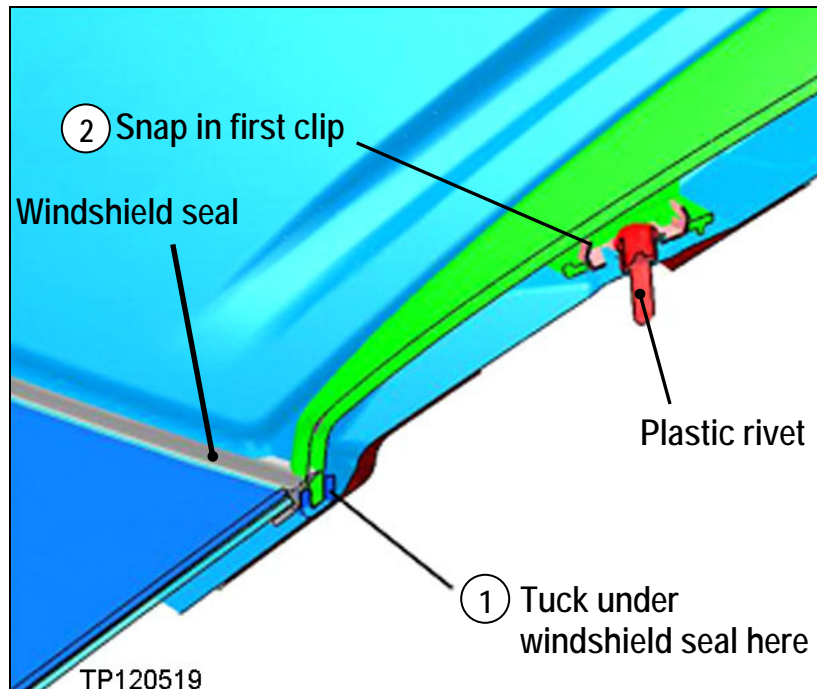

Figure 14

4. Snap in place the hook and rearmost clip into the back door (rear hatch) hinge.
  - First secure the hook, and then snap the clip in place.
    - The adjustable rear finisher (rear part of the molding) can slide fore/aft, making it easier to align the hook and clips.

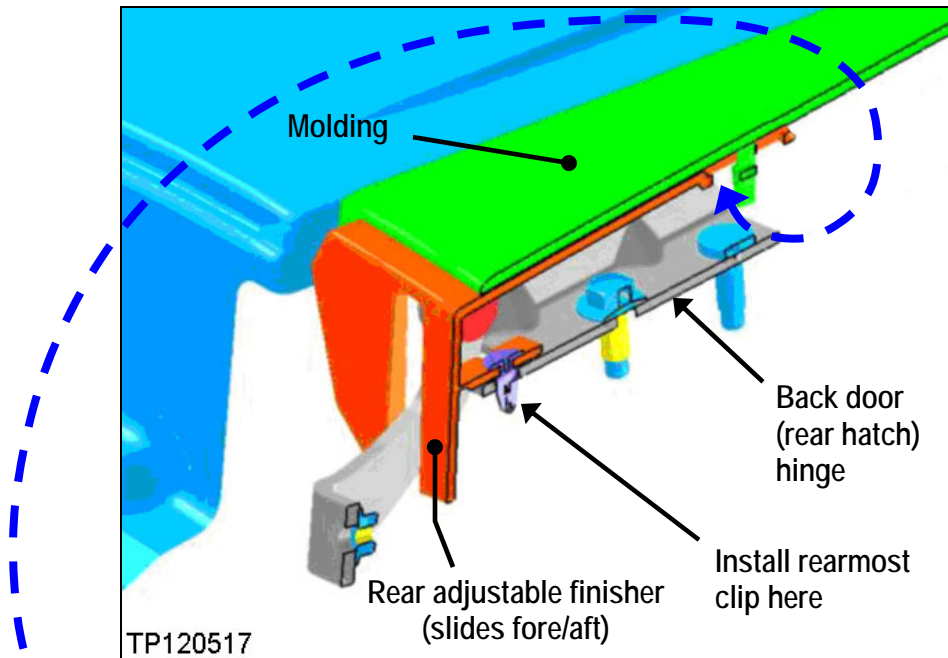

Figure 15

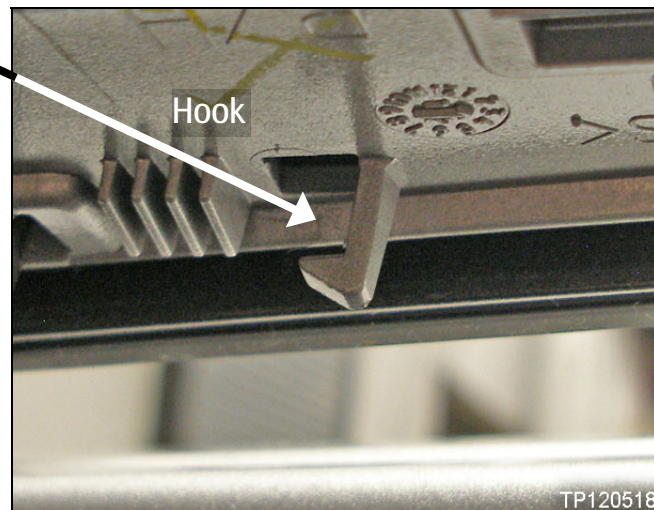

Figure 16 (viewed from underneath)

5. Snap in place the remaining clips.
6. If equipped, reinstall the cross bars (see Figure 2).
  - Apply a fresh coat of Loctite 242 or equivalent to the bolt threads, and then install the bolts.
    - T30 TORX bolts torque: 8.0 - 9.0 N·m (0.82 - 0.92 kg-m, 70.8 - 79.7 in lbs).



**PARTS INFORMATION**

| DESCRIPTION                          | COLOR CODE             | PART NUMBER | QTY  |
|--------------------------------------|------------------------|-------------|------|
| KIT-ROOF MLDG<br>(with cross bars *) | SILVER **              | 73865-9NA2A | 1    |
| KIT-ROOF MLDG<br>(w/o cross bars)    | Unpainted (primer) *** | 73865-9NA0A | 1    |
| LOCTITE® Threadlocker Blue 242®      | - -                    | - -         | **** |

\* Also applies to vehicles without cross bars, but has provisions for them.

\*\* The ends of the molding must be painted to match the ones being replaced.

\*\*\* The molding must be painted to match the ones being replaced.

\*\*\*\* Shop supply. Recommended, but an equivalent product may be used.

**CLAIMS INFORMATION**

Submit a Primary Part (PP) type line claim using the following claims coding:

| DESCRIPTION  | PFP | OP CODE | SYM | DIA | FRT |
|--|-----|---------|-----|-----|-----|
| RPL KIT-ROOF MLDG<br>WITHOUT ROOF RACK CROSS BARS - BOTH SIDES | (1) | BX5CAA  | ZJ  | 46  | 0.7 |

(1) Reference the Parts Information Table and use the applicable Molding Assembly Part Number as the Primary Failed Part (PFP).

OR

Submit a Primary Part (PP) type line claim using the following claims coding:

| DESCRIPTION   | PFP | OP CODE | SYM | DIA | FRT |
|---|-----|---------|-----|-----|-----|
| RPL KIT-ROOF MLDG<br>WITH ROOF RACK CROSS BARS - BOTH SIDES | (1) | BX5BAA  | ZJ  | 46  | 0.9 |

(1) Reference the Parts Information Table and use the applicable Molding Assembly Part Number as the Primary Failed Part (PFP).

CONTINUED ON THE NEXT PAGE

CLAIMS INFORMATION continued

AND (On the same repair line):

2-COAT S or M +STD C

| DESCRIPTION                          | OP CODE | FRT |
|--------------------------------------|---------|-----|
| Refinish Block Colored Plastic Parts | ZV1HAA  | 1.0 |
| Preparation and Mix                  | ZZ99AA  | 1.3 |

Colors: FAJ – LT Green; K23 – Silver; KH3 - Black

OR

2-COAT P, PM, GR, F or T +STD C

| DESCRIPTION                          | OP CODE | FRT |
|--------------------------------------|---------|-----|
| Refinish Block Colored Plastic Parts | ZV1HAA  | 1.1 |
| Preparation and Mix                  | ZZ99AA  | 1.5 |

Colors: EAJ – DK Olive; K50 BL Grey; NAB- DK RED

OR

3-COAT P +STD C

| DESCRIPTION                          | OP CODE | FRT |
|--------------------------------------|---------|-----|
| Refinish Block Colored Plastic Parts | ZV1HAA  | 1.3 |
| Preparation and Mix                  | ZZ99AA  | 1.7 |

Color: QAA - White

Expense Code:

| EXPENSE CODE | DESCRIPTION         | MAX AMOUNT |
|--------------|---------------------|------------|
| 019          | Paint and Materials | (2)        |

(2) Calculate the Material Allowance = (\$25.00/Hr.) x (paint-repair total FRT)

