



---

# SERVICE BULLETIN

---

Classification: AT15-018	Reference: NTB15-102	Date: January 25, 2016
-----------------------------	-------------------------	---------------------------

---

## 2013-2015 ALTIMA; WHINE NOISE FROM CVT AT HIGHWAY SPEEDS

**APPLIED VEHICLE:** 2013-2015 Altima (L33) with 4-cyl engine only

### IF YOU CONFIRM:

A whine or grind type noise heard during acceleration and/or constant highway speeds.

- The level of noise may increase as vehicle speed increases.

### AND

There are no other drivability issues or stored DTCs related to the CVT assembly (CVT).

### ACTION:

Refer to the **REPAIR FLOW CHART** on page 3 for repair procedure.

Refer to page 2 for information on special service tools.

**NOTE:** Parts Kit #1 (see **PARTS INFORMATION**) must be available at the time the reduction gear bearing shim selection procedure, starting on page 11, is to be performed.

**IMPORTANT:** The purpose of **ACTION** (above) is to give you a quick idea of the work you will be performing. You **MUST** closely follow the entire **SERVICE PROCEDURE** as it contains information that is essential to successfully completing this repair.

Nissan Bulletins are intended for use by qualified technicians, not 'do-it-yourselfers'. Qualified technicians are properly trained individuals who have the equipment, tools, safety instruction, and know-how to do a job properly and safely. **NOTE:** If you believe that a described condition may apply to a particular vehicle, **DO NOT** assume that it does. See your Nissan dealer to determine if this applies to your vehicle.

## Required Special Tools

- J-50255 - CVT Service Tool Kit: Includes Gauge Block J-50271, Digital Depth Gauge J-50272, Puller J-50273, and Race Installer J-50274
- J-51923 – J-Hook
- J-50273-2 – Puller Legs
- J-50818 – Converter Seal Installer
- J-50393 – CVT Case Differential Seal Installer
- J-50394 – Converter Housing Differential Seal Installer
- J-8092 – Driver Handle
- J-25721-A – Slide Hammer
- J-50255-UPD - Slide Hammer Bolt

These tools are considered "Essential" and have been previously sent to each dealer.

Additional tools and/or replacement parts can be ordered from TECH-MATE at 1-800-662-2001.

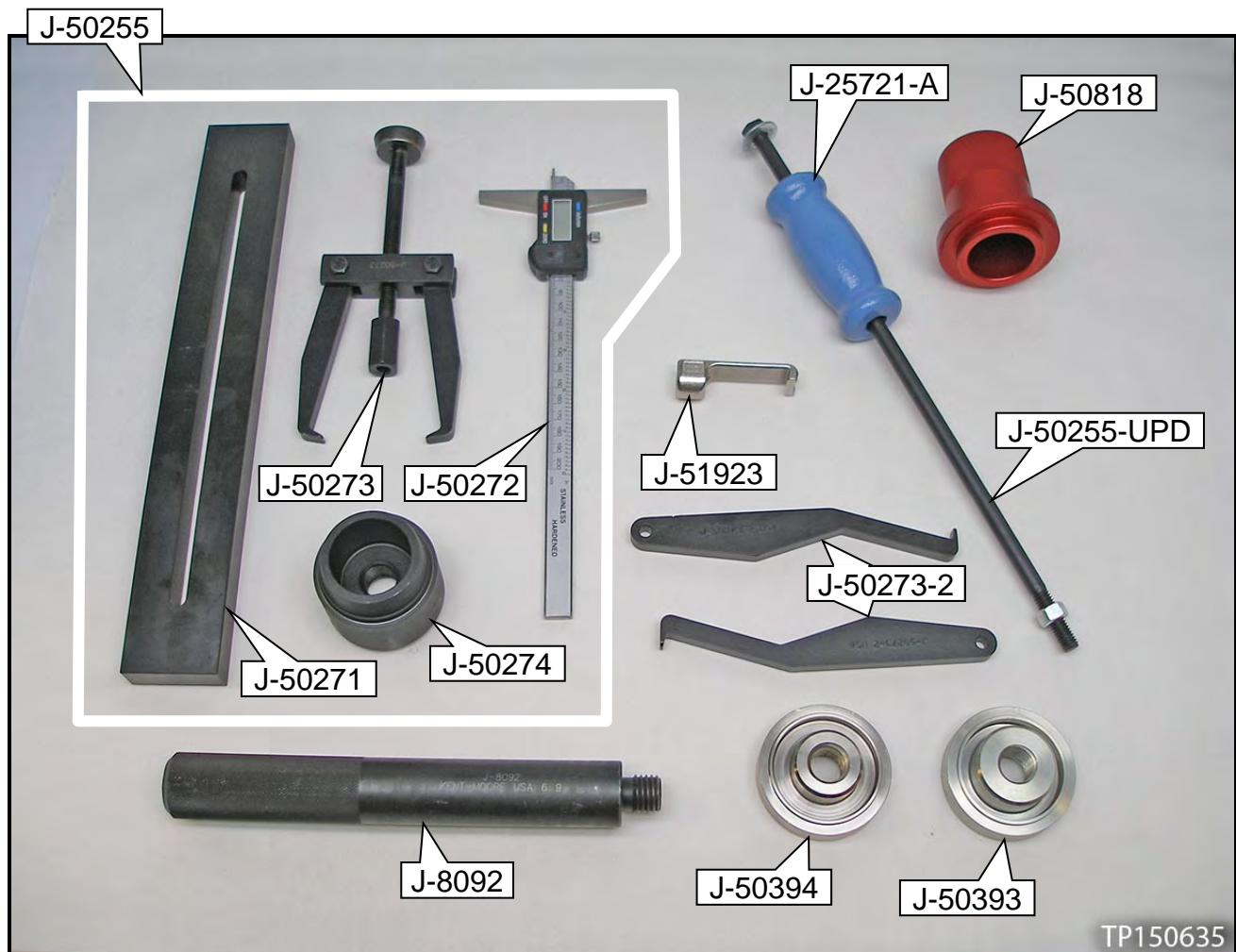
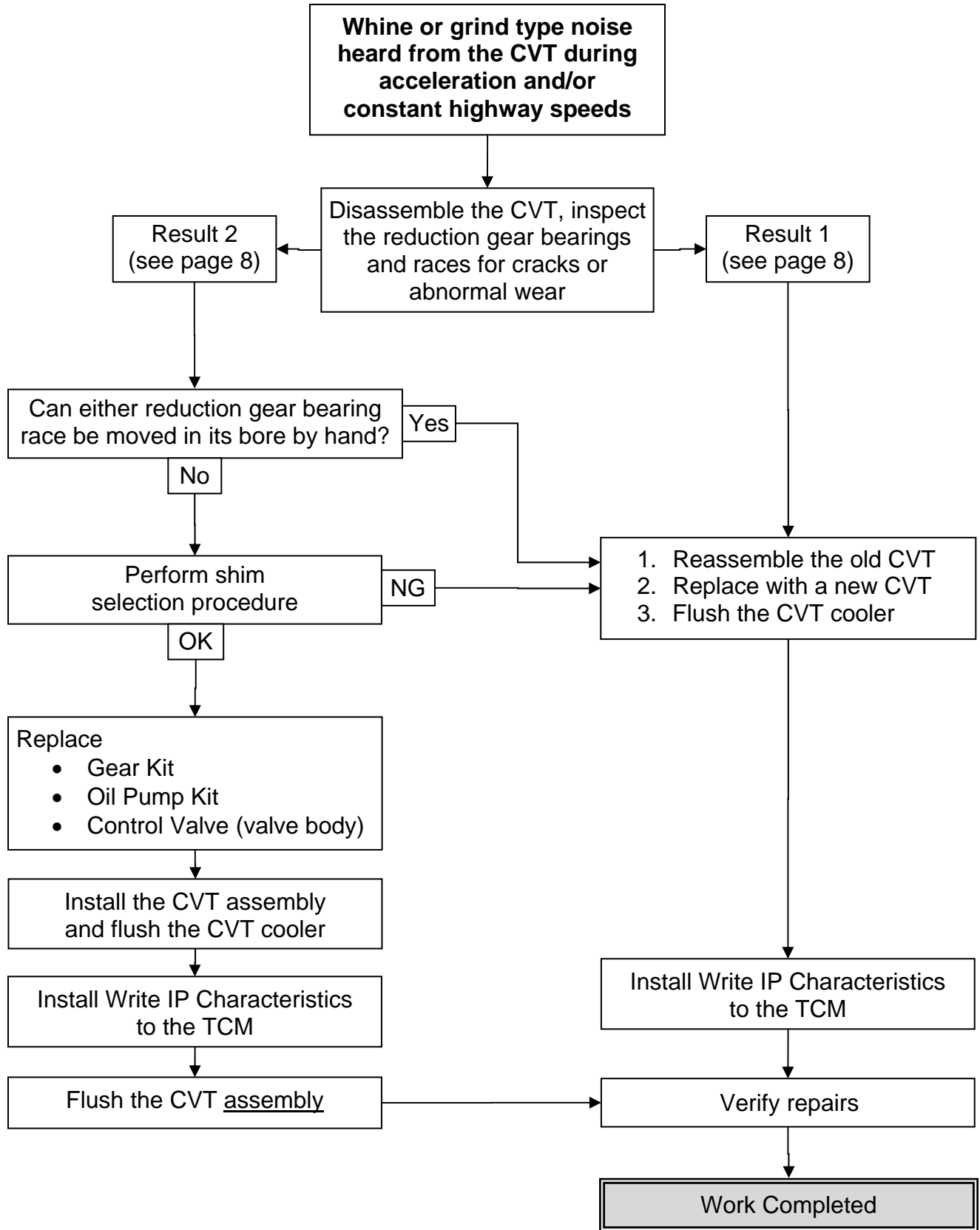

Figure A

## REPAIR FLOW CHART



## SERVICE PROCEDURE

### Disassemble CVT for Inspection

#### PRECAUTIONS WHEN DISASSEMBLING A CVT ASSEMBLY

Transmissions are vulnerable to particles (dust, metal, lint, etc.).

- When disassembling a CVT, make sure your work environment (shop, workbench, etc.), the transmission area (sub-frame, oil pan, harness connector, etc.), and your hands are free of contamination.
- Make sure all parts are clean prior to assembling / installing. Unpack service parts just before installation.
- Only disassemble the parts which are mentioned in this bulletin.

**NOTE:** If metal debris is found in the oil pan during disassembly, this is OK. The CVT will be flushed after reassembly, or replaced.

1. Write down all radio station presets.

Presets	1	2	3	4	5	6
AM						
FM 1						
FM 2						
SAT 1						
SAT 2/3						
Bass	Treble		Balance	Fade	Speed Sen. Vol.	

2. Disconnect both battery cables, negative cable first.
3. Remove the CVT from the vehicle.
  - Refer to the Electronic Service Manual (ESM), section **TM-Transaxle & Transmission**, for CVT removal.

**WARNING:** CVT Fluid and parts may be hot.

4. Place the CVT on a workbench, use wood or plastic blocks to keep the CVT steady.

**CAUTION:** The primary speed sensor may become damaged when handling the CVT. Be careful when handling the CVT (see Figure 1).

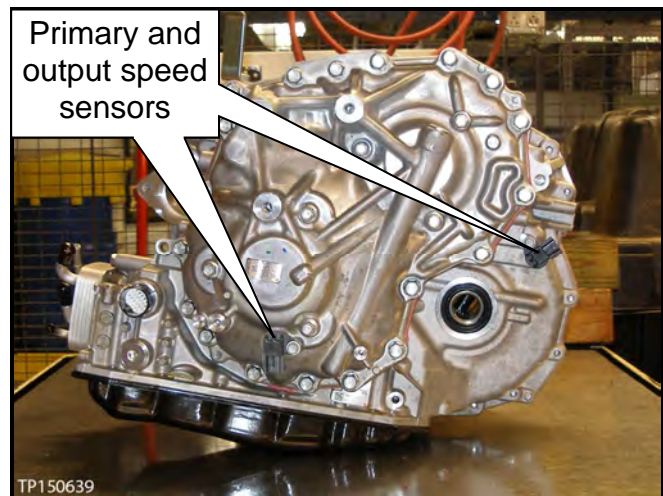

Figure 1

5. Remove all 23 converter housing mounting bolts (see Figure 2).

**NOTE:** These bolts will be replaced with new ones and will not be reused.

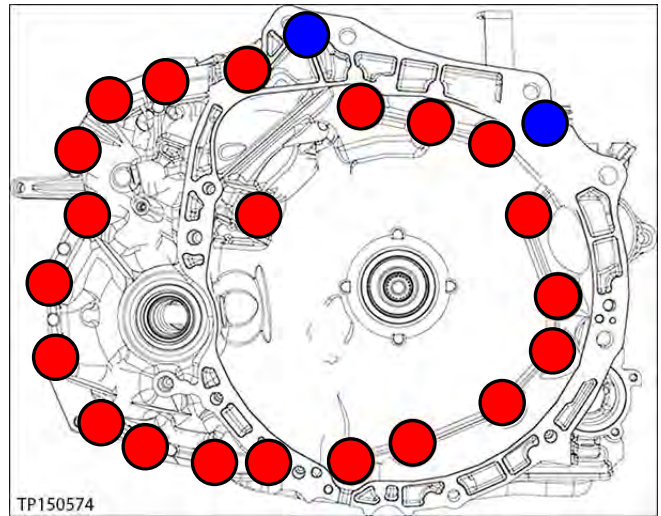

Figure 2

6. Separate and then remove the converter housing from the CVT case.

- Use Slide Hammer J-25721-A and Slide Hammer Bolt J-50255-UPD with J-Hook J-51923 at the cutout areas similar to the one shown in Figure 3 and 4.

**CAUTION:** Do not pry between mating surfaces.

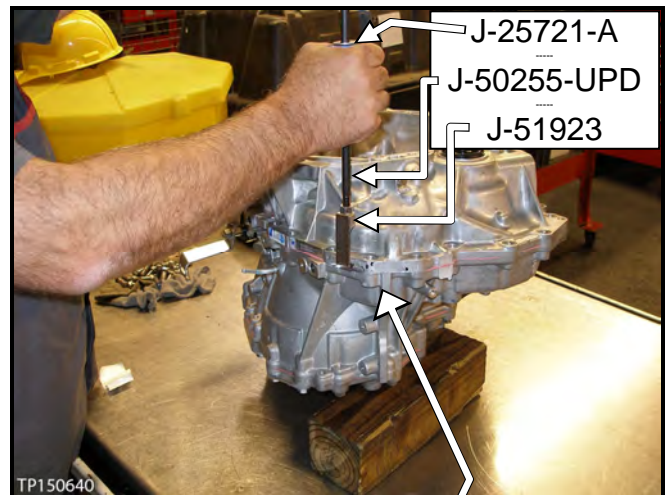

Figure 3

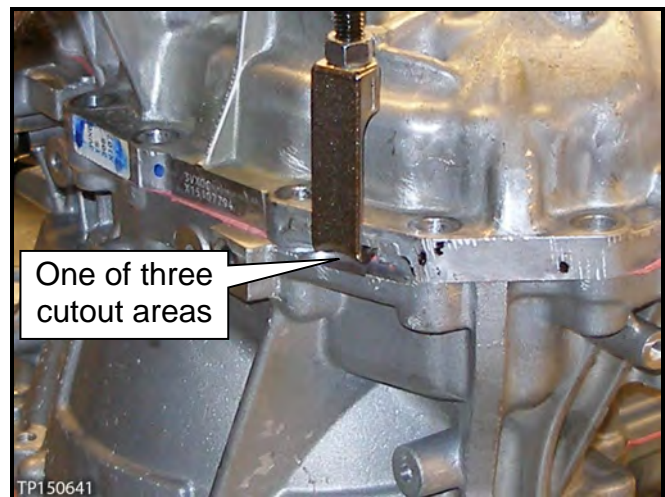

Figure 4

7. Remove the O-ring from the input shaft (see Figure 5).
  - This O-ring will be replaced with a new one.

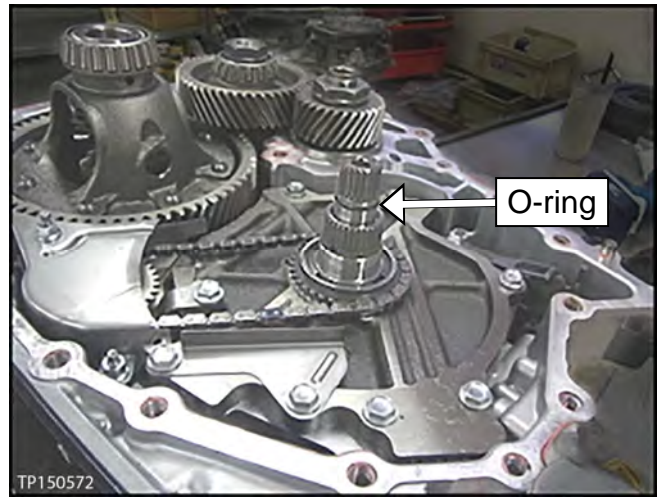

Figure 5

8. Carefully remove the reduction gear assembly (see Figure 6).

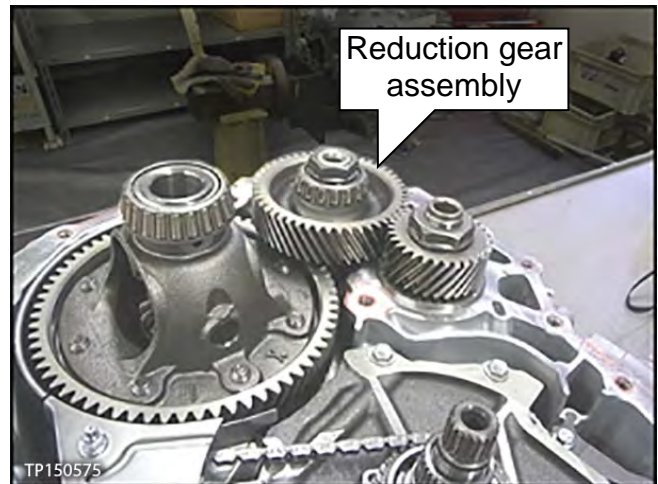

Figure 6

9. Carefully remove the differential assembly (see Figure 7).

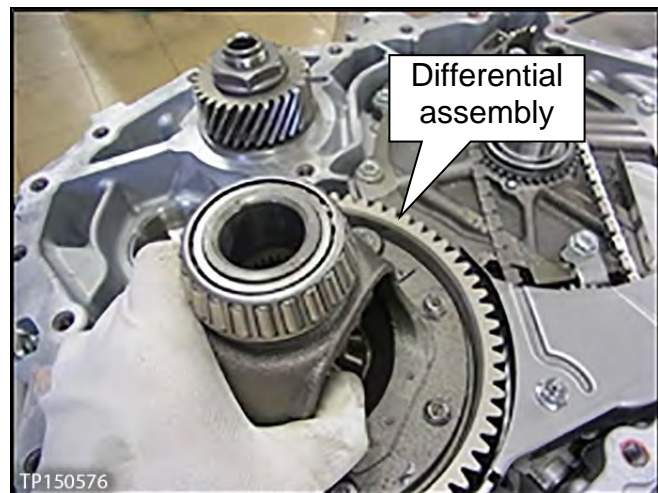
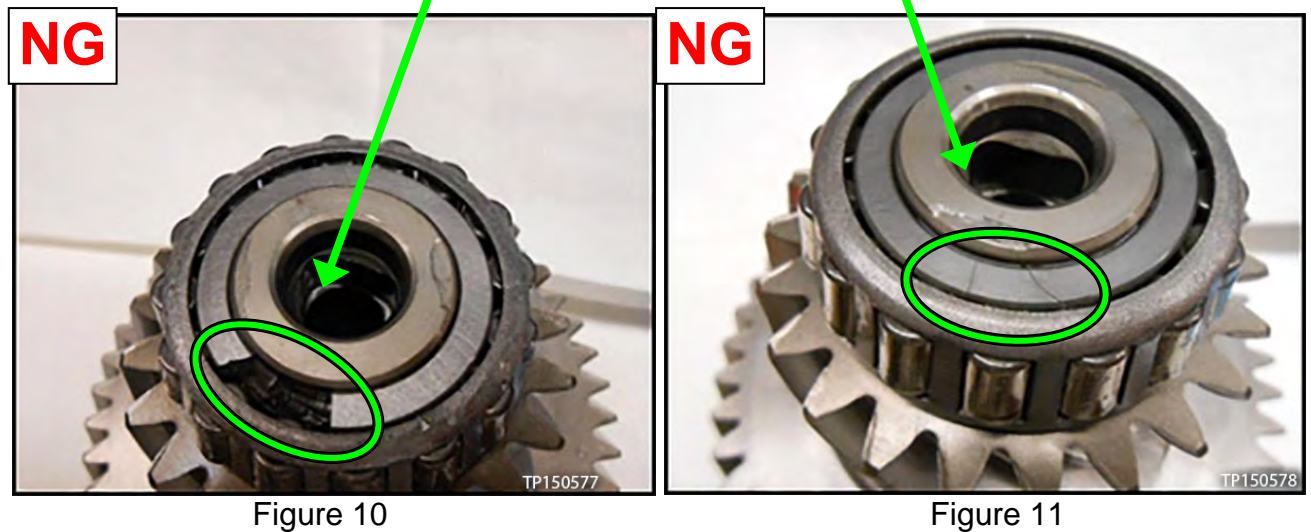
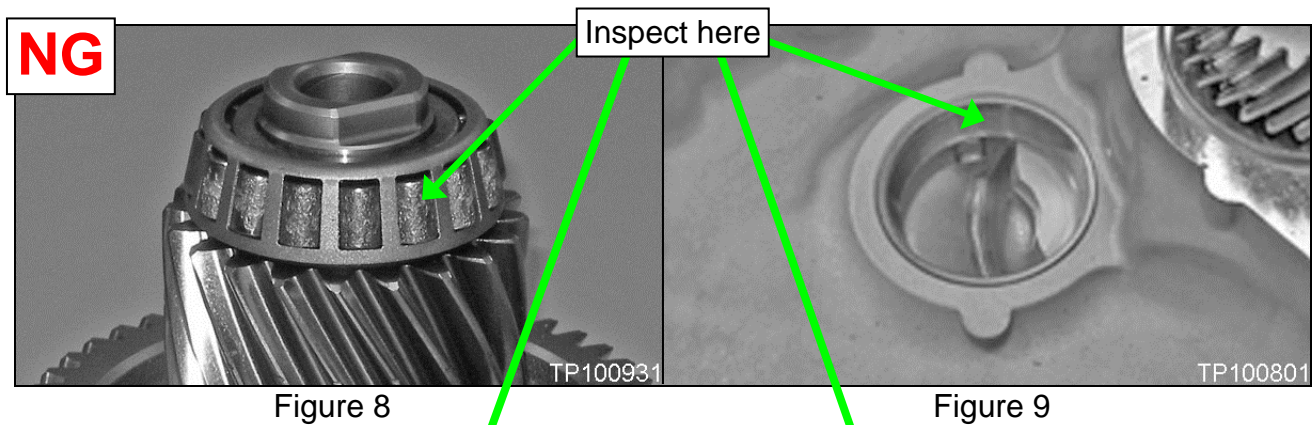

Figure 7

## Reduction Gear Bearing Inspection

1. Visually inspect the outer races and rollers of the reduction gear's tapered bearings for damage. Figure 8, 10, and 11 show examples of cracked and damaged rollers and races.
  - If no damage found, **or any wear or damage is found that is not similar to the “NG” examples below**, go to step 2 on the next page.
  - If damage found that is similar to the examples below, skip to step 3 on the next page.



2. Result 1: When no damage is found (or damage/wear not similar to the “**NG**” examples on page 7), replace the CVT.
  - a. Record a video of the outer bearings showing no or dissimilar damage (see page 43 for details).
  - b. Assemble the original CVT.
  - c. Replace the CVT.
    - To finish repairs, skip to page 43, **Install CVT Assembly**.

**NOTE:**

- CVT assembly flushing is not performed with replacement CVTs.
- The CVT cooler(s) is always flushed whether repairing or replacing the CVT. Refer to NTB15-013 for cooler cleaning procedure.

3. Result 2: If similar damage is found, inspect the fit of both reduction gear outer bearing races. Figure 12 shows the race in the CVT case.

- a. Both races cannot be moved by hand: Go to **Remove Reduction Gear Bearing Outer Races** on the next page.
- b. Either race can be moved by hand: Replace the CVT.
  - aa. Record a video of the outer bearing race that can be moved by hand (see page 43 for details).
  - bb. Assemble the original CVT.
  - cc. Replace the CVT.
    - Skip to page 43, **Install CVT Assembly**.

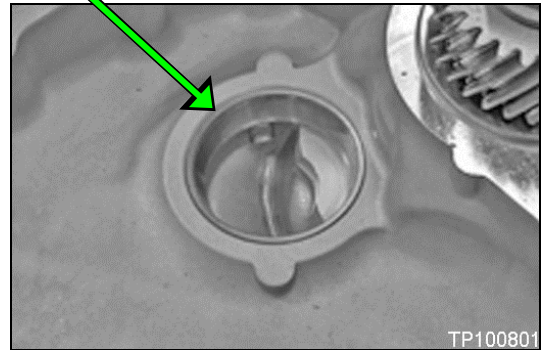

Figure 12

**NOTE:**

- CVT assembly flushing is not performed with replacement CVTs.
- The CVT cooler(s) is always flushed whether repairing or replacing a CVT. Refer to NTB15-013 for cooler cleaning procedure.



## Remove Reduction Gear Bearing Outer Races

1. Remove the reduction gear outer race from the converter housing (see Figure 13).
  - Use Slide Hammer J-25721-A with Slide Hammer Bolt J-50255-UPD to Puller J-50273 and Puller Legs J-50273-2 (see Figure 13 and 14).
  - Make sure the puller jaws grip under the races.

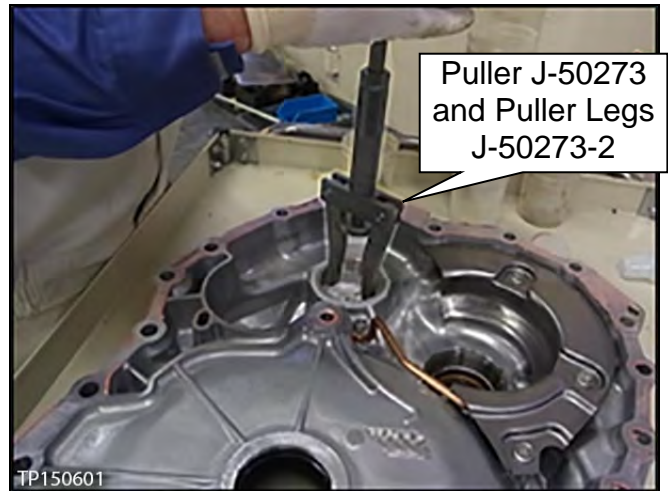

Figure 13

2. Remove the reduction gear outer race from the CVT case (see Figure 14).
  - Make sure the puller jaws grip under the races.

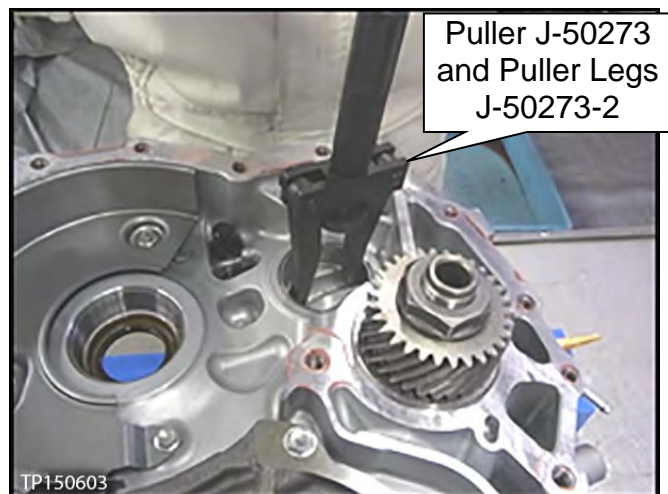

Figure 14

3. Remove any shims located behind the races.

**NOTE:** The removed races and shim(s) will not be reused.



Figure 15

4. Thoroughly clean both bearing race bores.

5. Thoroughly clean off the end of the output speed sensor (see Figure 16).

After cleaning, go to the next page.

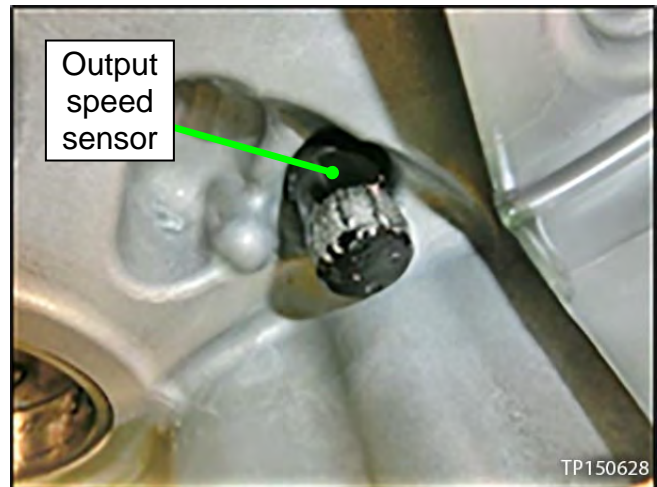

Figure 16

## Reduction Gear Bearing Shim Selection Procedure

The following is a summary of how to select a shim with the correct thickness:

- (1) Measure the bearing outer race bore depth of the CVT case (Mc).
- (2) Measure the bearing outer race bore depth of the converter housing (Mh).
- (3) Read the reduction gear assembly height from the label attached to the new reduction gear assembly package.
- (4) Select a shim with the measurements above using the NTB15-102 Shim Calculator in CONSULT-III plus (C-III plus).

**NOTE:** CVT Service Tool Kit J-50255 and C-III plus are needed to perform the shim selection procedure.

- The Service Tool Kit's contents are shown on page 2.
1. First, calibrate Digital Depth Gauge J-50272. For step 1a – 1d, refer to Figure 17.
    - a. Turn the depth gauge ON, set it to “mm” measurement.
    - b. Place the depth gauge's Datum level flush on top of Gauge Block J-50271.
    - c. Carefully slide the depth gauge down until it bottoms out on the gauge block.
    - d. With the depth gauge bottomed out, press the “ZERO” switch.
      - The depth gauge's display should now read 0.00 mm.

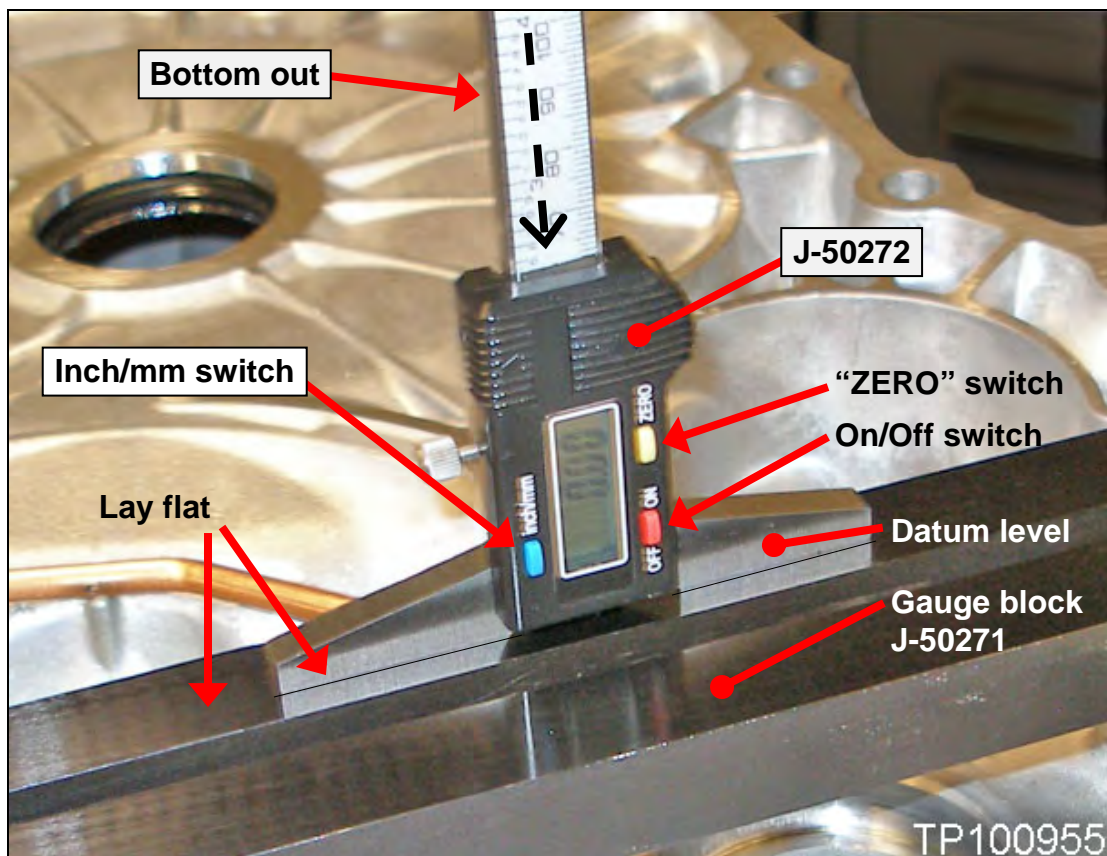

Figure 17

2. Thoroughly clean the mating surfaces of the CVT case.

**CAUTION:** Do **NOT** use sanding discs or similar abrasive tools. Use brake spray or equivalent solvent and lint-free towels only.

- Make sure the brake spray or solvents used are compatible with local regulations.

For step 3-7, refer to Figure 18, 19, and 20.

3. Position the gauge block over the outer race bore in the CVT case.

4. Position the depth gauge through the middle of the gauge block.

- Make sure the depth gauge's Datum level is flush on top of the gauge block.

5. Carefully slide the depth gauge down until it bottoms out where the shim and race bottoms out.

6. Write down the value shown in the depth gauge's display.

7. Perform step 5 and 6 on the opposite side of the race bore.

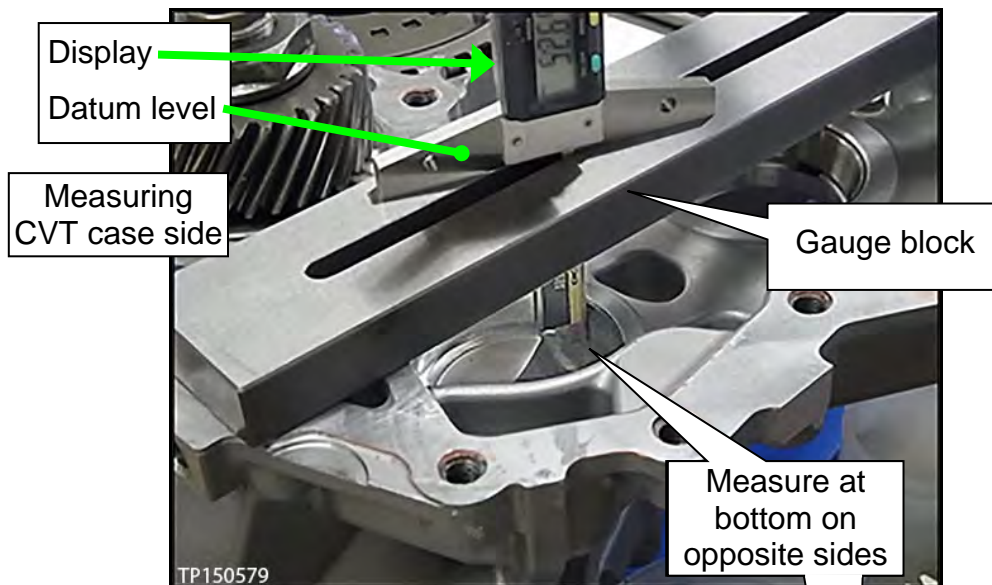

Figure 18

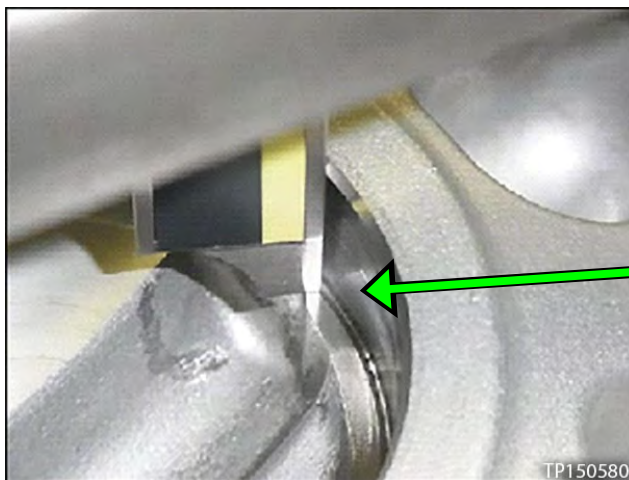

Figure 19

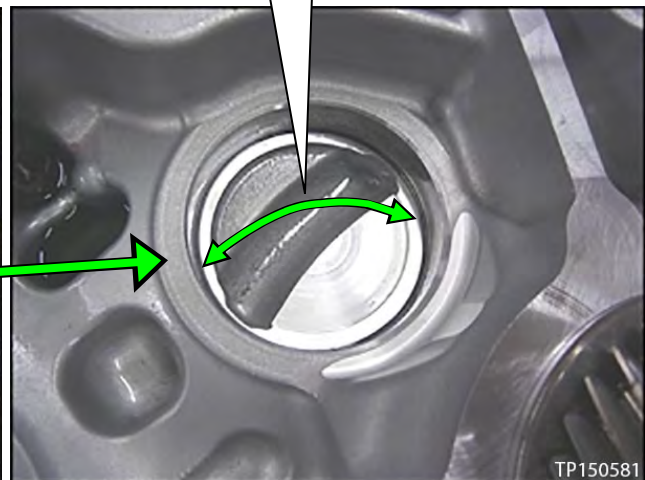

Figure 20

8. Subtract 20 mm from each measurement.

**EXAMPLE:** 70.8 mm and 70.0 mm are the measured values. Subtracting 20 mm from each value equals 50.8 mm and 50.0 mm, respectively.

**NOTE:**

- 20 mm is the thickness of the gauge block.
- All measurements are made in millimeters.

9. Add the two measurements, and then divide by two.

- Write down the calculated value as “Mc”.

**EXAMPLE:** 50.8 mm plus 50.0 mm equals 100.8 mm. 100.8 mm divided by 2 equals 50.4 mm Mc.

10. Perform step 2-9 on the converter housing's outer race bore (see Figure 21).

- Write down the calculated value as “Mh”.

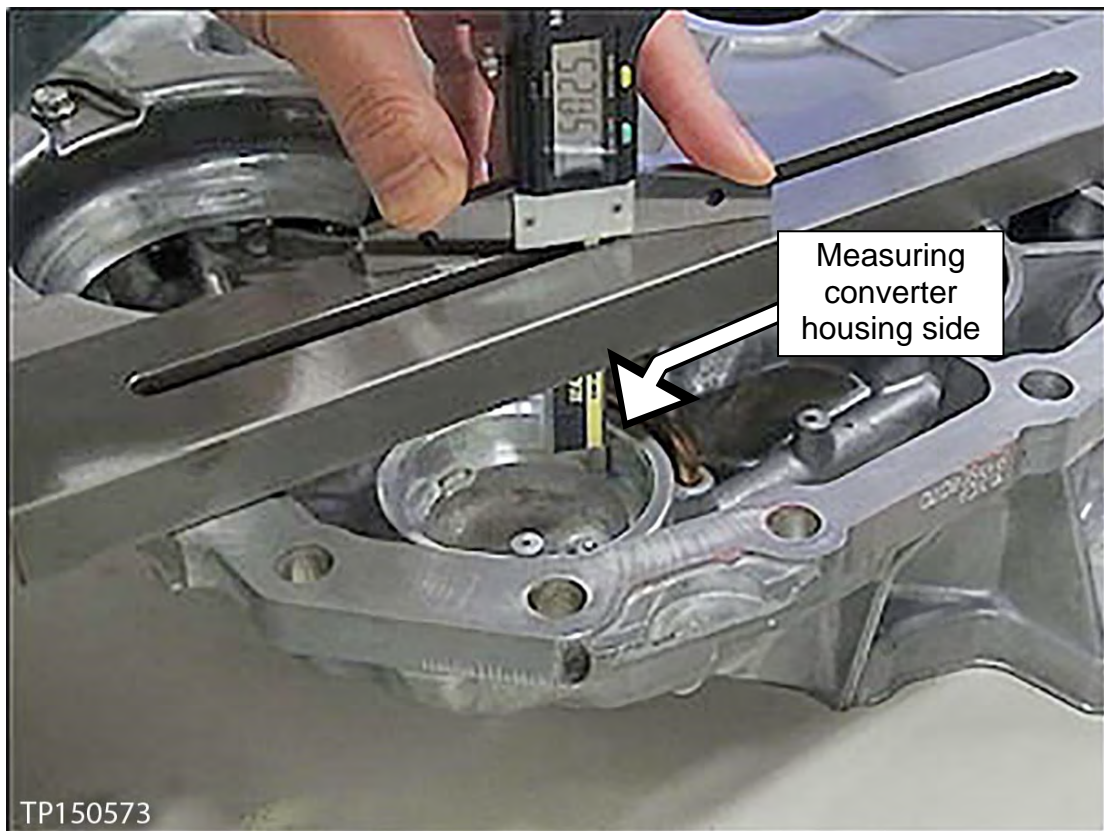

Figure 21

11. Open ASIST, and then go to **ASIST>Specialty Tools>NTB15-102 Shim Calculator** to access the calculation tool.

12. With the calculation tool displayed, input the measurement values in the correct boxes from page 13, step 9 and 10 (see Figure 22).

**NOTE:** All measurements must be inputted in millimeters.

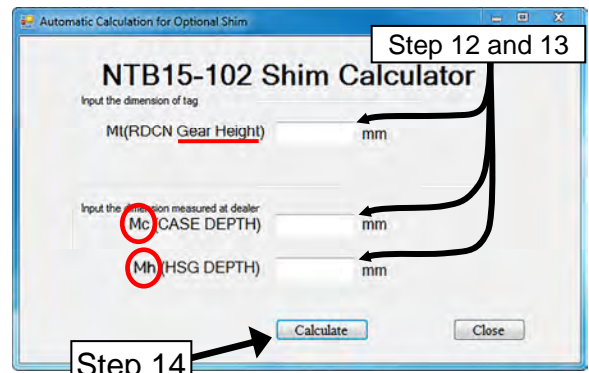

Figure 22

13. Input the height measurement of the reduction gear assembly (see Figure 22).

- The measurement value is located on a label attached to the reduction gear's packaging (see Figure 23).

14. Click on **Calculate** (see Figure 22).

- A shim part number will appear (see example in Figure 24).

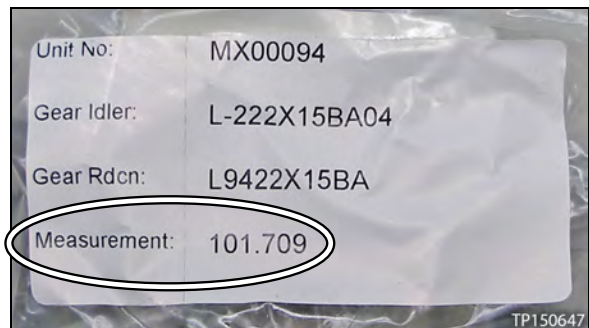

Figure 23

15. Obtain or order this shim from your parts department.

- If two (2) part numbers display, install one (1) shim of each part number.
- All shims will be installed on the CVT case side later on during the assembly procedure.
- Always restock the shim kit. This will assure these shims are immediately available for other future repairs.

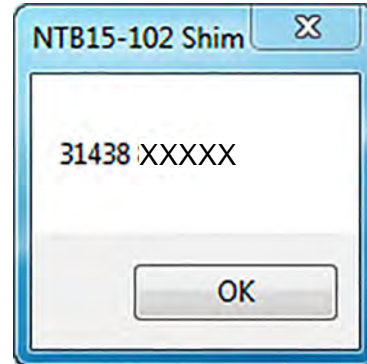

Figure 24

16. If the window in Figure 25 appears:

- Verify all measurements, calculations, and inputted values are correct, and then try the calculation again.
- If the same message appears again, get a screen shot or photo of the message showing all measurements. Call the Powertrain Call Center (PCC) for the next step, and then attach the screen shot of the calculation to the PCC form.

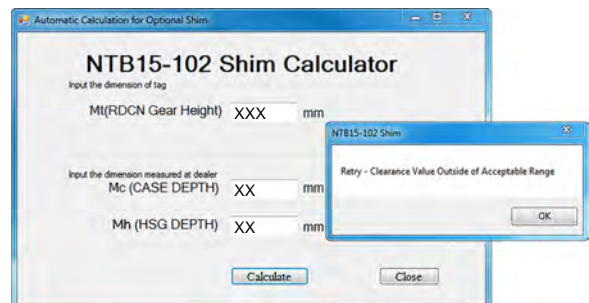

Figure 25

17. If Figure 24 appeared, finish step 15, and then go to the next page.

## Remove Control Valve Assembly (Valve Body)

1. Remove the 19 oil pan bolts, and then remove the CVT oil pan and gasket (see Figure 26).
  - Save the oil pan bolts. They will be reused.
  - Save the magnets. They will be reused.
  - The oil pan will be replaced with a new one.
  - The oil pan gasket will be replaced with a new one.

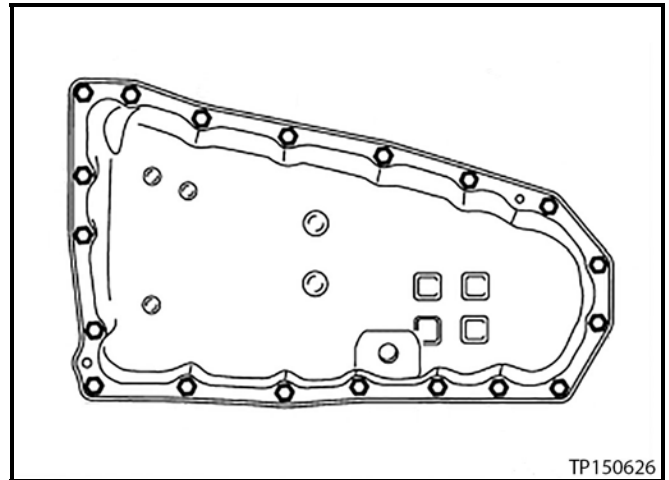

Figure 26

2. Remove the nut and lock washer to remove the manual plate (see Figure 27).
  - These parts will be reused.

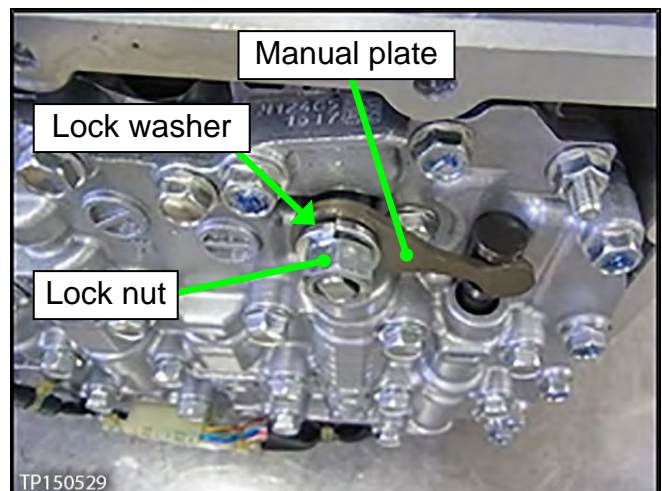

Figure 27

3. Remove the three (3) oil strainer mounting bolts, and then remove the oil strainer with O-ring (see Figure 28).
  - The oil strainer and O-ring will be replaced.

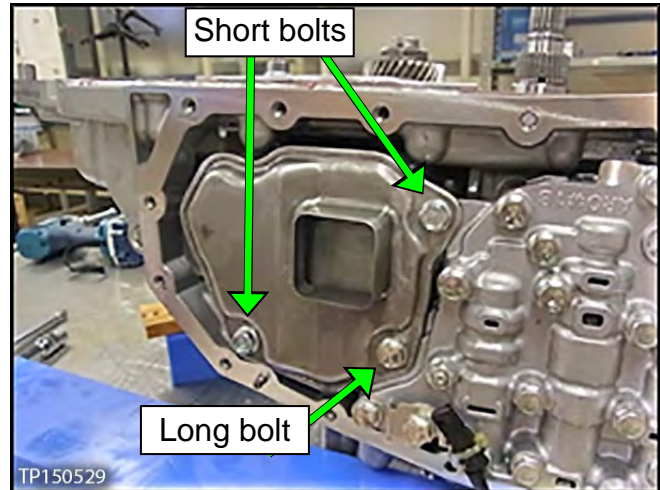

Figure 28

4. Remove the two (2) oil strainer bracket bolts, and then remove the oil strainer bracket (see Figure 29).

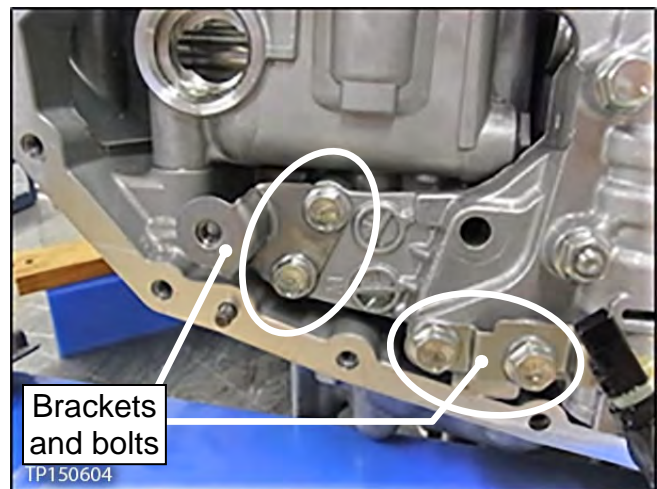

Figure 29

5. Remove the two (2) fluid temp sensor bolts, and then disconnect the wiring harness connector (see Figure 29 and 30).

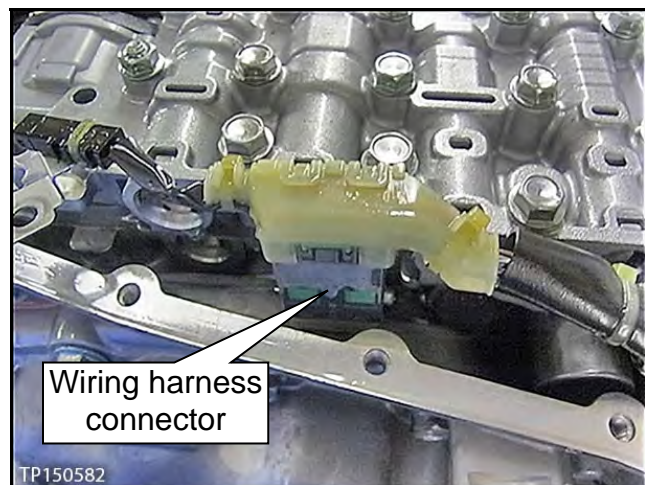

Figure 30



6. Remove the nine (9) valve body mounting bolts, and then carefully remove the valve body (see Figure 31).

**NOTE:** Eight bolts are 54 mm long, and one bolt is 44 mm long.

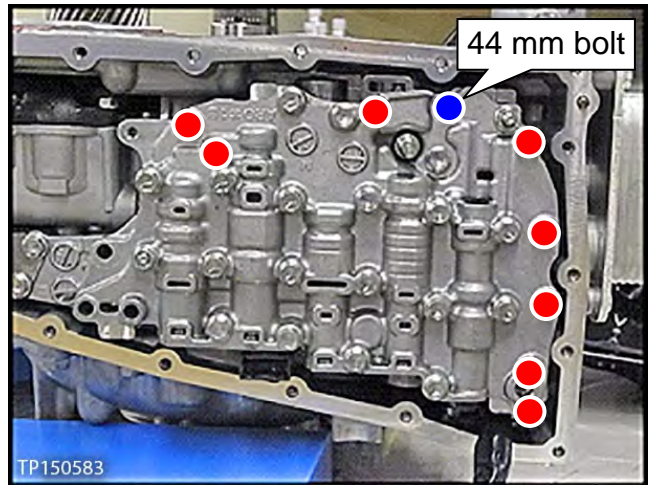

Figure 31

7. Carefully remove the lip seal (see Figure 31a).

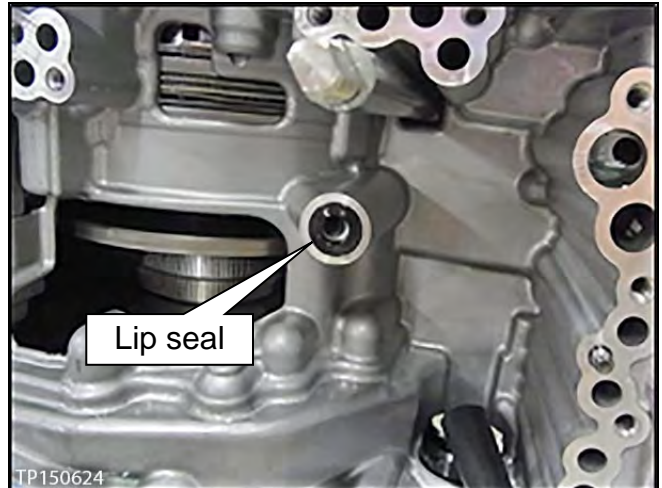

Figure 31a

## Remove Oil Pump Assembly

1. Remove the two (2) nuts, and then remove the first baffle plate (see Figure 32).

**CAUTION:** To avoid rounding off these nuts, it is best to use a 3/8 drive 6-pt 10 mm socket.

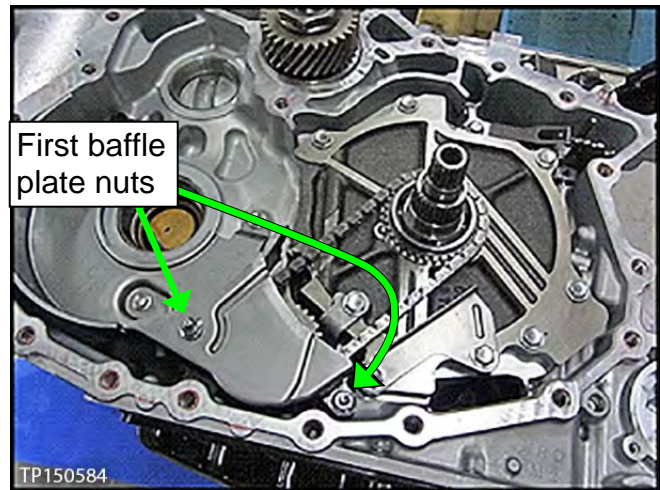

Figure 32

2. While spreading out the snap ring, remove as an assembly the driven and drive sprockets and oil pump chain (chain). See Figure 33 and 35.
3. Remove the thrust washer (see Figure 34).

- The thrust washer will be reused.

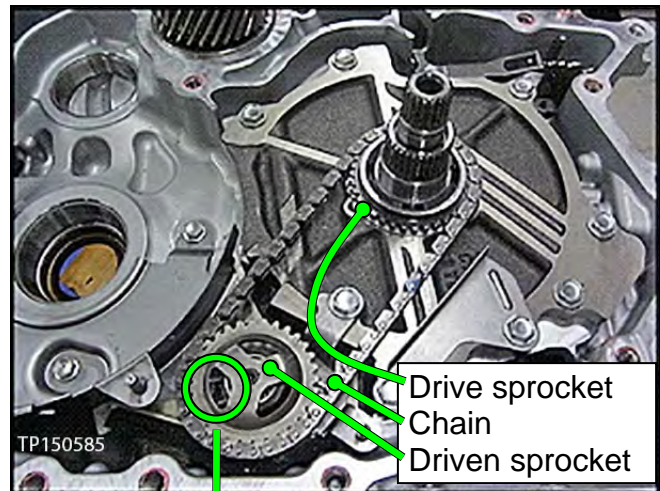

Figure 33

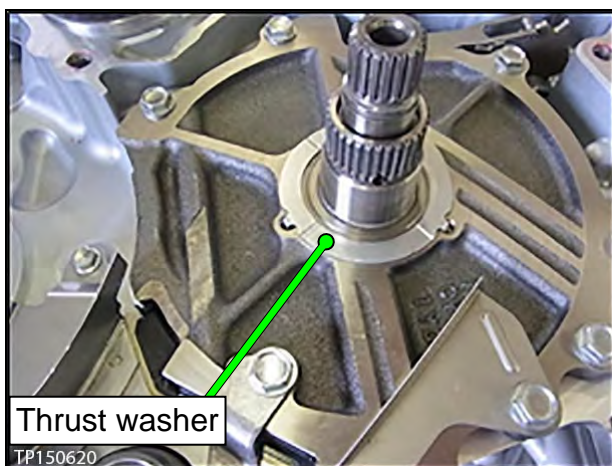

Figure 34

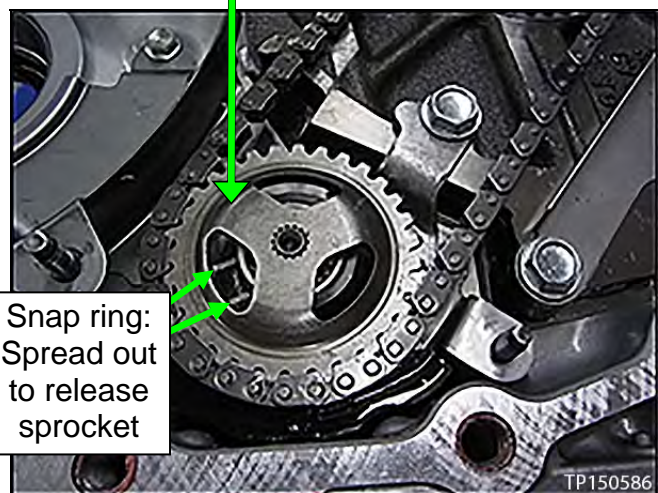

Figure 35

4. Remove the two (2) bolts, and then remove the "L" bracket (see Figure 36).

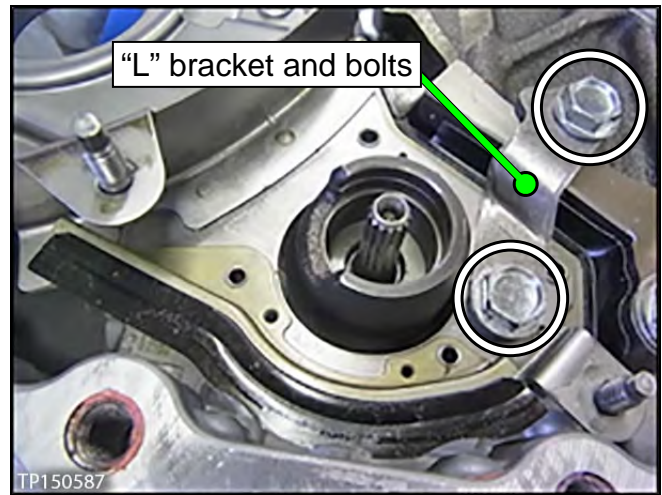

Figure 36

5. Remove the three (3) bolts, and then remove the second baffle plate (see Figure 37).

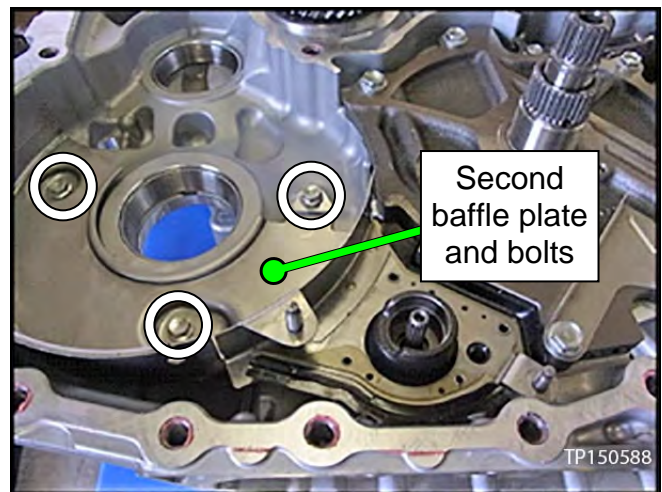

Figure 37

6. Remove the two (2) bolts, and then remove the third baffle plate (see Figure 38).

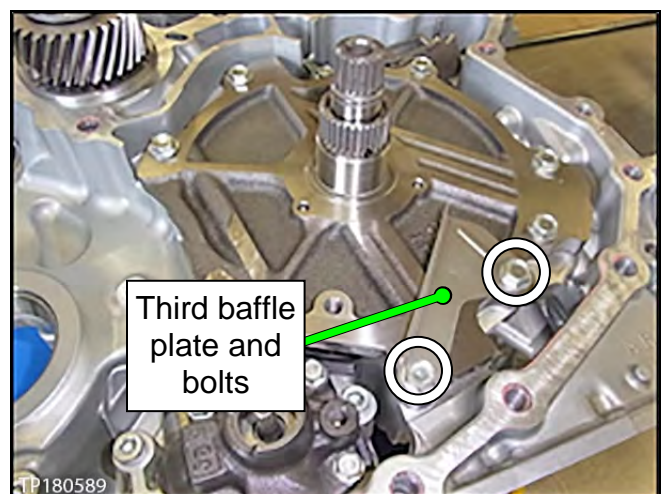

Figure 38

7. Remove the five (5) bolts, and then remove the oil pump cover (see Figure 39).

**CAUTION:** Be careful when removing and handling the oil pump cover. The lathe cut seals, installed on the bottom side, will be reused.

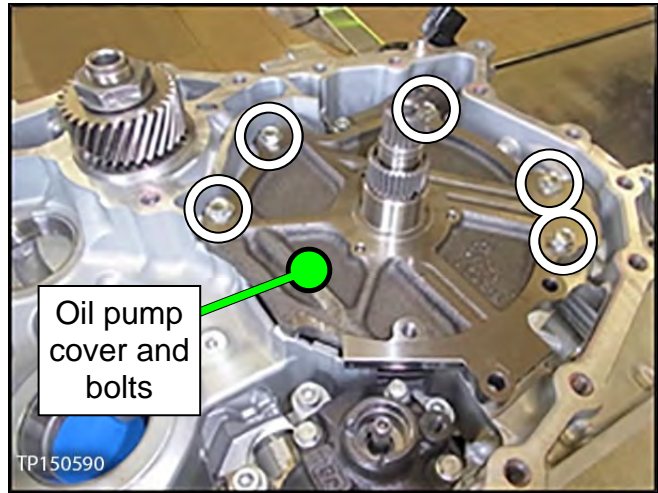

Figure 39

8. Remove the oil pump fitting bolt located above the left rear corner of the oil pan (see Figure 40).



Figure 40

9. Remove the three (3) Allen™ head bolts, and then remove the oil pump (see Figure 41).

**NOTES:**

- The Allen™ head bolts will be reused.
- The oil pump and snap ring will be replaced.

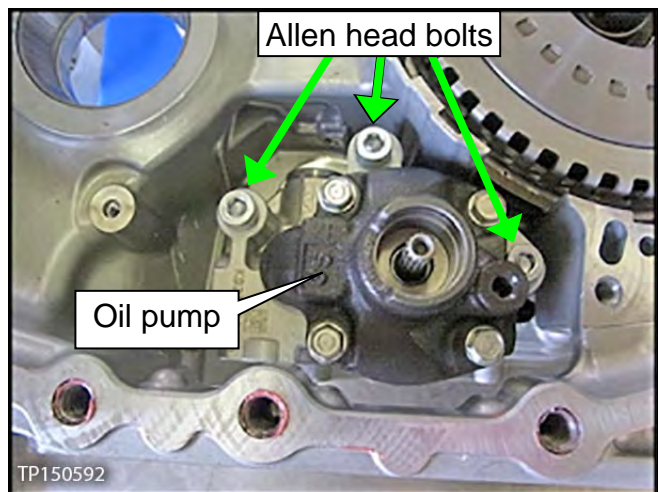

Figure 41

## Remove CVT Fluid Filter

1. Remove the four (4) bolts, and then remove the CVT fluid filter cover (see Figure 42).

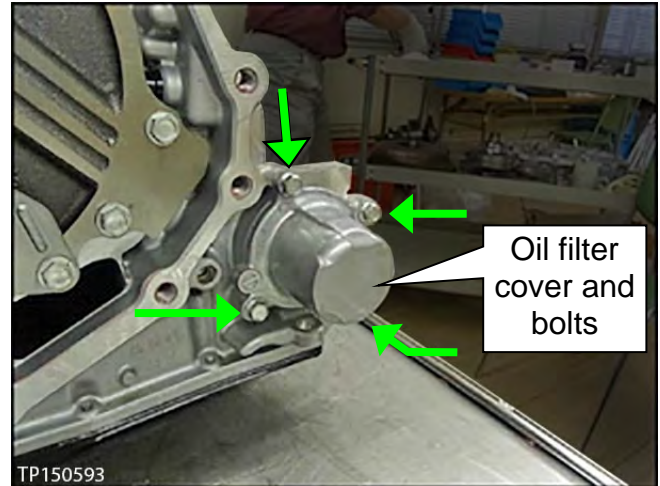

Figure 42

2. Remove the CVT fluid filter with grommet seal and O-ring seal (see Figure 43).
  - The filter and seal will be replaced with new ones.
  - Figure 43 does not show the grommet seal. It is fitted to the bottom end of the filter.



Figure 43

## Clean Oil Passages in CVT Case, Oil Pump Cover, and CVT Filter Area

**NOTE:** In this section, brake spray or a suitable cleaning solvent and compressed air will be used to clean out oil passages in the CVT assembly. Make sure the brake spray or solvents used are compatible with local regulations.

**WARNING:** Wear eye protection when using compressed air.

**CAUTION:** Regulate air pressure up to a maximum of 75 PSI.

1. Spray in all oil passages in the CVT case where shown in Figure 44.
2. Next, apply compressed air pressure in the same oil passages.

**NOTE:** Do not stand in front of the passages shown in Figure 45 during compressed air use.

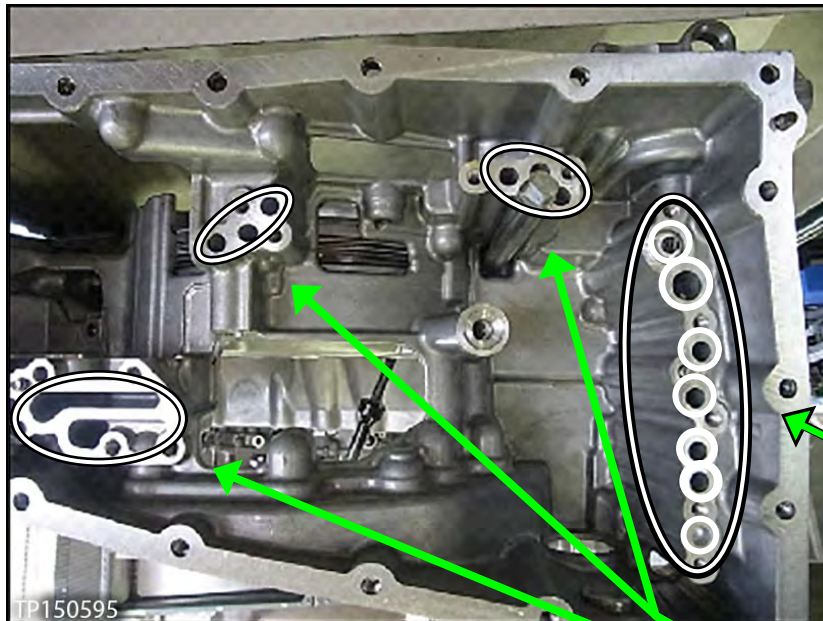

Figure 44

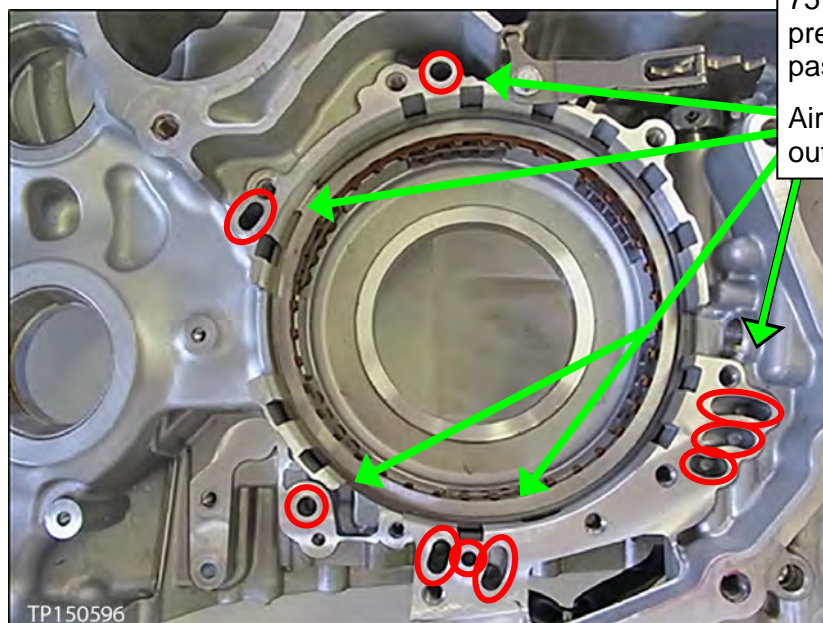

Figure 45

Apply cleaner, and then 75 PSI maximum air pressure in these passages

Air pressure comes out these passages

3. Clean the area where the CVT fluid filter fits (see Figure 46).
  - Make sure the old filter grommet seal is removed.

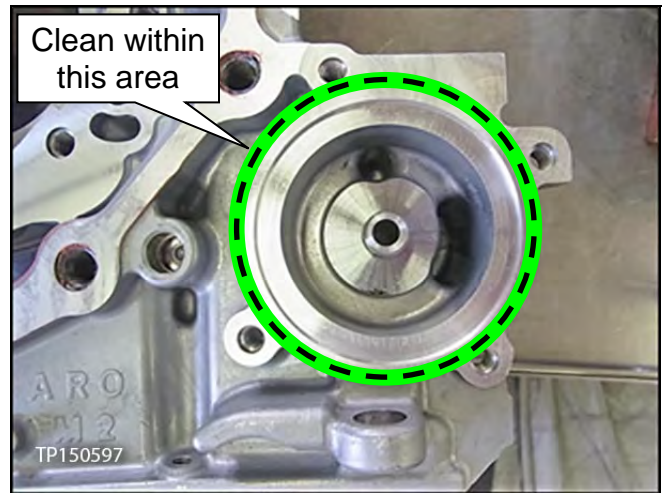

Figure 46

4. Remove the three (3) bolts, and then remove the baffle plate from the converter housing (see Figure 47).

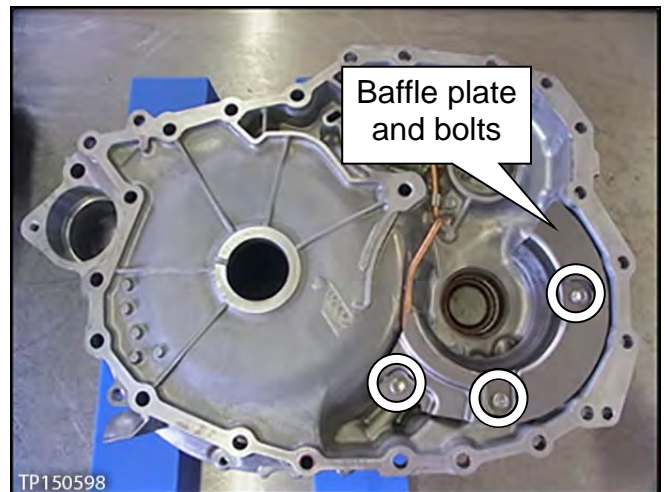

Figure 47

5. Remove the bolt, and then remove the lubrication tube and its bracket (see Figure 48).

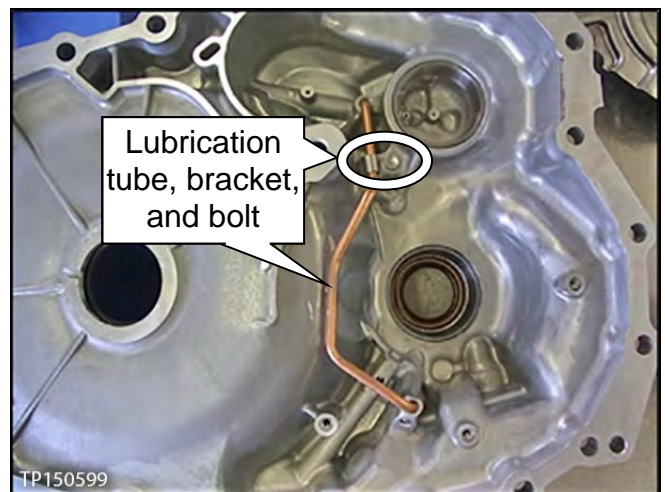

Figure 48

- Clean out/spray in the oil passages in the converter housing and lubrication tube (see Figure 49 and 50).

**NOTE:** Do not stand in front of the passages shown in Figure 49 and 50 during compressed air use.

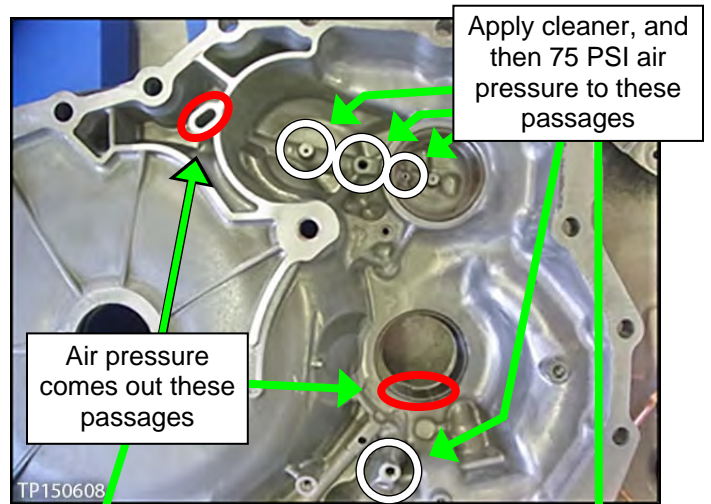

Figure 49



Figure 50

- Install the lubrication tube and bracket (see Figure 51).

- Bolt torque: 5.9 N•m (0.6 kg-m, **52 in-lb**)

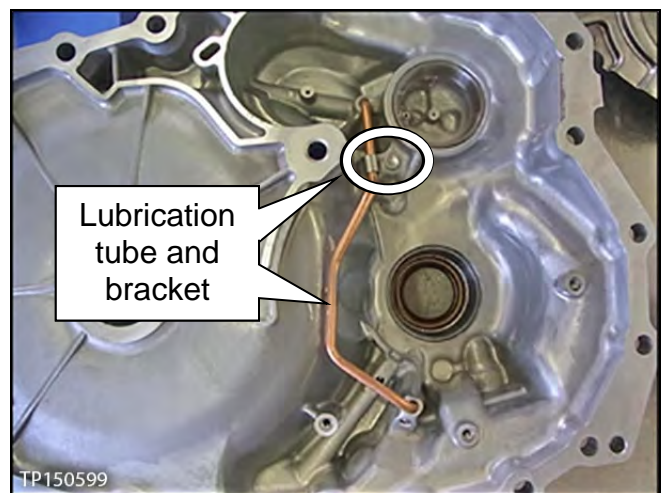

Figure 51



8. Install the baffle plate with three (3) bolts (see Figure 52).

- Bolts torque: 5.9 N•m (0.6 kg-m, **52 in-lb**)

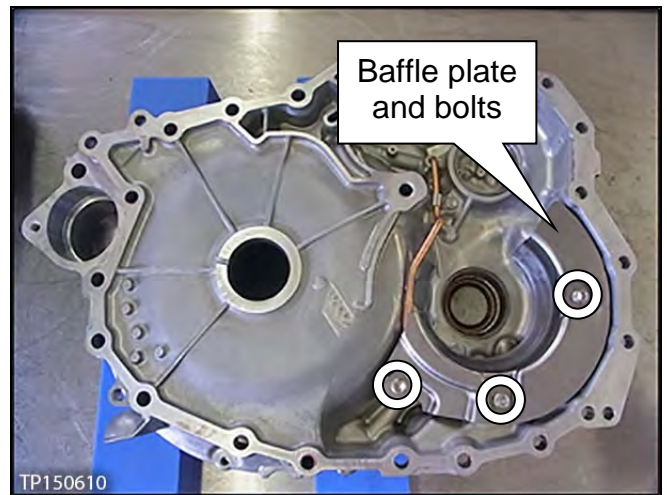

Figure 52

9. Clean out/spray in the oil pump cover oil passages where shown in Figure 53 and 54.

**NOTE:** Do not stand in front of the passage shown in Figure 53 during compressed air use.

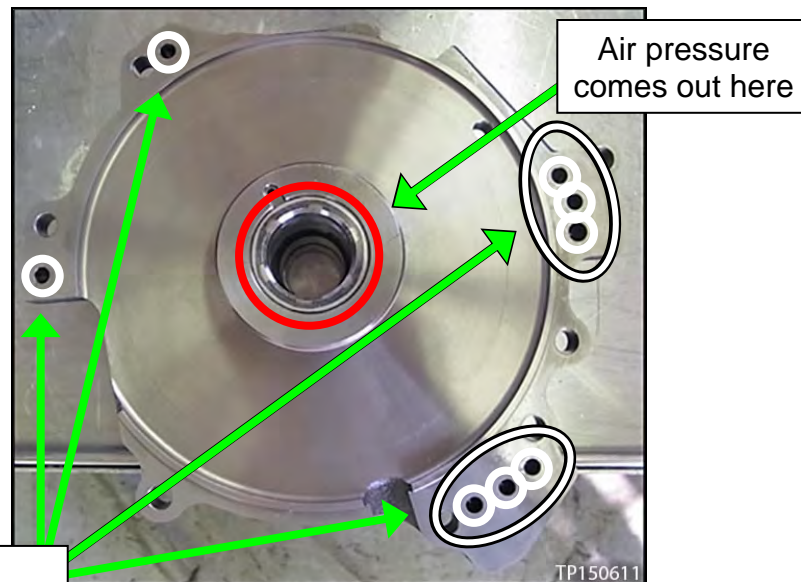

Figure 53

Apply 75 PSI maximum air pressure in these passages

Air pressure comes out here



Figure 54

- Make sure all exposed internal areas of the CVT (including the oil pan and magnets) have been thoroughly cleaned.
- Keep all parts covered with a lint-free covering when repairs have stopped.

## Reassemble CVT Assembly

### Replace Both Differential Side Oil Seals and Torque Converter Seal

1. Remove the following seals using suitable tools:

- CVT case (drive shaft) differential side oil seal
  - Converter housing (drive shaft) differential side oil seal
  - Torque converter seal
- See Figure 55, 56, and 57.

**CAUTION:** Be careful not to damage the seal bore surfaces.

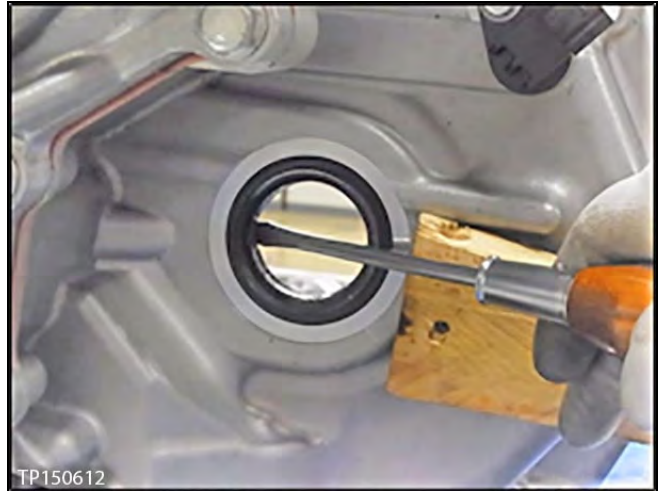

Figure 55



Figure 56



Figure 57

2. Install a new converter seal with Seal Installer J-50818 (see Figure 58).
  - The converter housing seal will be 0.5 mm below the bore's surface when the seal installer bottoms out.
  - Apply a light coat of CVT fluid to the converter seal's lip surfaces.

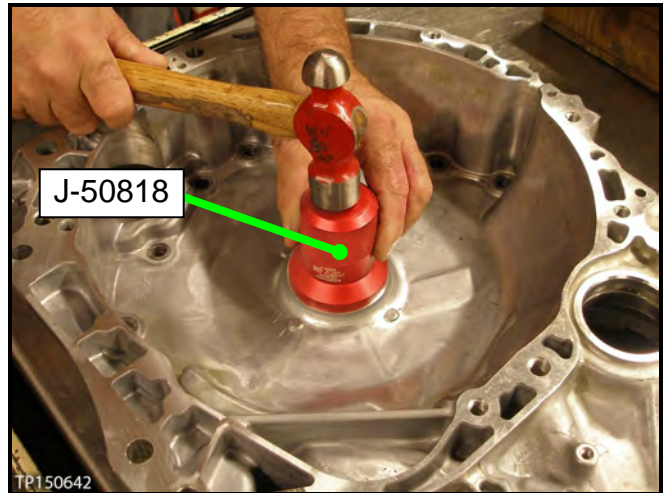

Figure 58

3. Do not install either differential side oil seal at this time. They are to be installed during step 11 (page 41).

**NOTE:** Both differential side oil seals are to be installed after the CVT has been completely assembled.

## Install / Assemble CVT Internal Parts

1. Install the new select shim(s) in the CVT case outer race bore (see Figure 59).

- Make sure the race bore is thoroughly clean before shim installation.

### CAUTION:

- Never re-use an old shim.
- All new shims are to be installed in the CVT case outer race bore. Never install the new shim(s) in the converter housing race bore.



Figure 59

2. Install the new outer races using Race Installer J-50274 from Tool Kit J-50255, and Driver handle J-8092 (see Figure 60 and 61).

- Make sure the bores are thoroughly clean before installing the races.
- Make sure the races are fully seated.

**NOTE:** The tools shown in Figure 60 and 61 are similar but may not look exactly the same as J-50274 and J-8092.

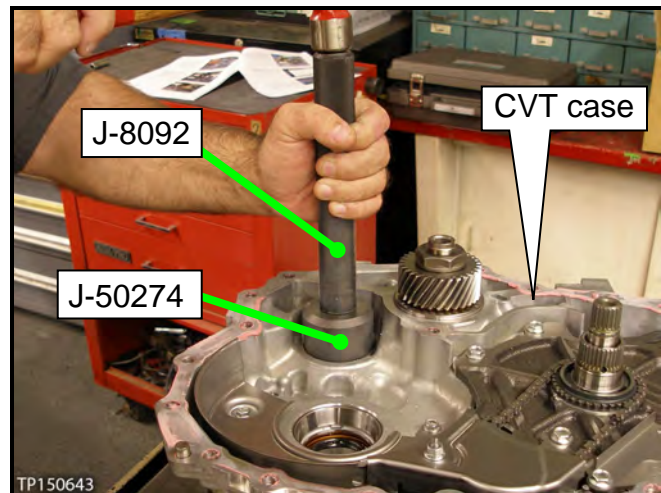

Figure 60

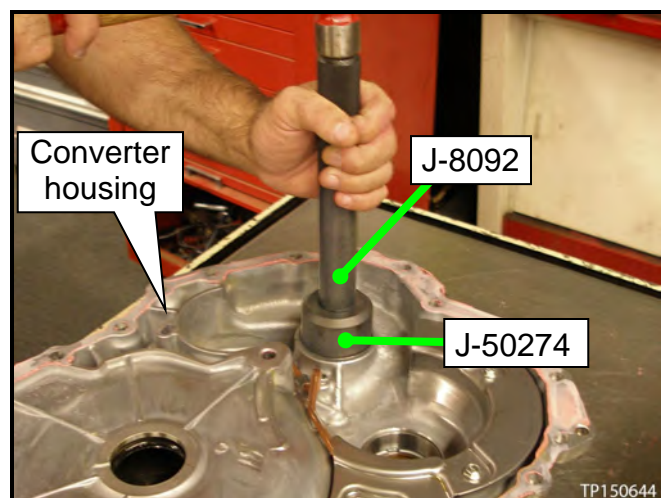

Figure 61

3. Install the new oil pump using the three (3) Allen™ head bolts (see Figure 62).
  - Finger tighten the Allen™ head bolts at this time.

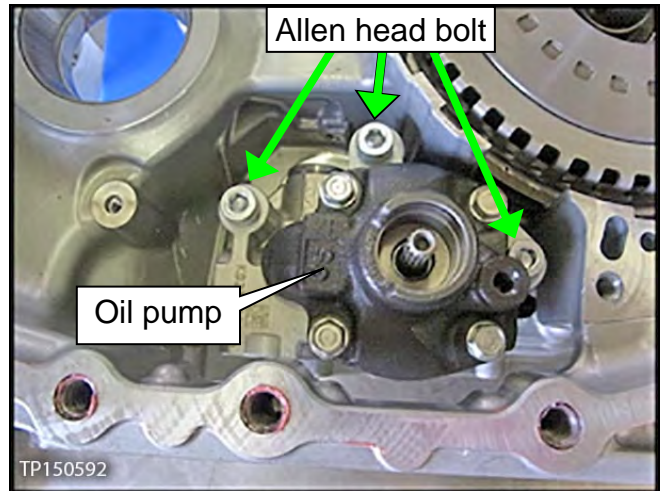

Figure 62

4. Put in place a new O-ring on the fitting bolt, and then coat it with CVT fluid (see Figure 63).



Figure 63

5. Install the oil pump fitting bolt finger tight (see Figure 64).
6. Torque the three (3) Allen™ head bolts and fitting bolt.
  - Allen™ head bolts torque: 17.6 - 20.6 N•m (1.79 - 2.1 kg-m, **13.0 - 15.2 ft lb**)
  - Fitting bolt torque: 26.0 - 30.0 N•m (2.65 - 3.06 kg-m, **19.2 - 22.1 ft lb**)

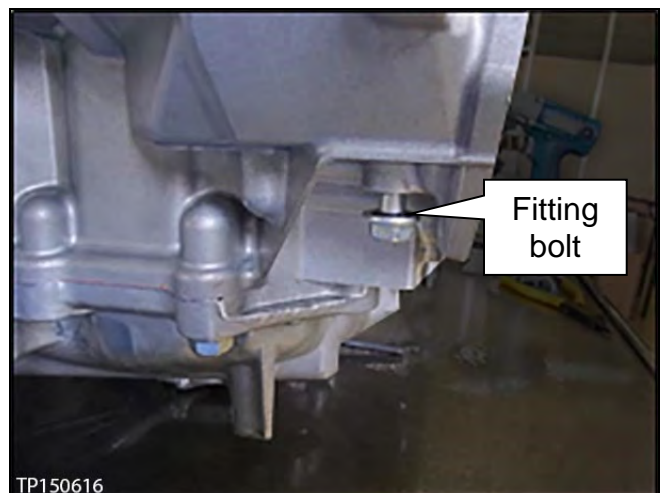

Figure 64

7. Apply petroleum jelly or equivalent to the oil pump cover's lathe cut seals (see Figure 65).

**NOTE:** The existing seals are being reused. They are not being replaced.



Figure 65

8. Install the oil pump cover and third baffle plate with related bolts finger tight (see Figure 66).

- Do not force the oil pump cover in place.
- Make sure the oil pump cover is fully seated before installing the bolts.
- Do not torque these bolts at this time.

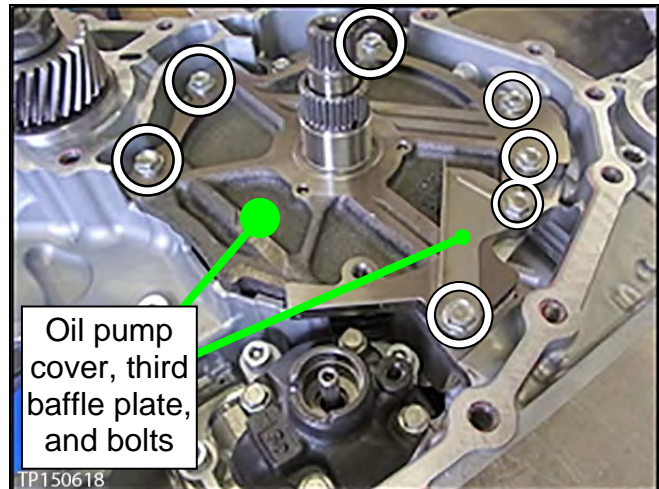

Figure 66

9. Install the second baffle plate and "L" bracket with related bolts finger tight (see Figure 67).

10. Torque the bolts in step 8 and 9 in the following order:
- a. Second baffle plate bolts: 5.9 N•m (0.6 kg-m, **52.2 in lb**)
  - b. "L" bracket bolts: 25.5 N•m (2.6 kg-m, **19 ft lb**). Torque **1**, and then **2**.
  - c. Oil pump cover and third baffle plate bolts torque: 19.0 - 20.6 N•m (1.9 kg-m, **14 ft lb**)

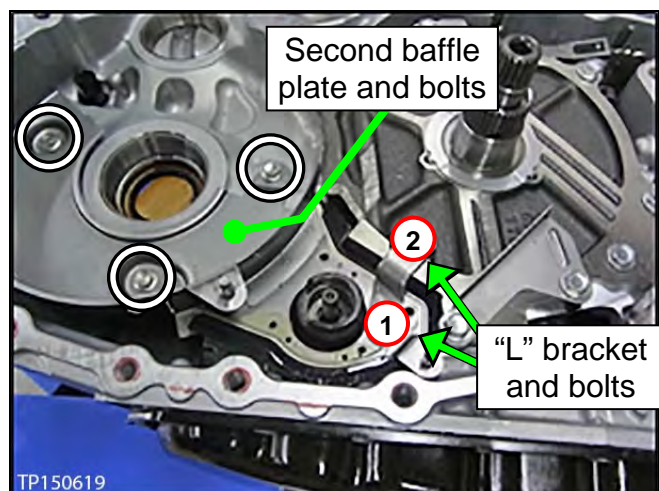

Figure 67

11. Install a new snap ring in the new oil pump (see Figure 68 and 69).

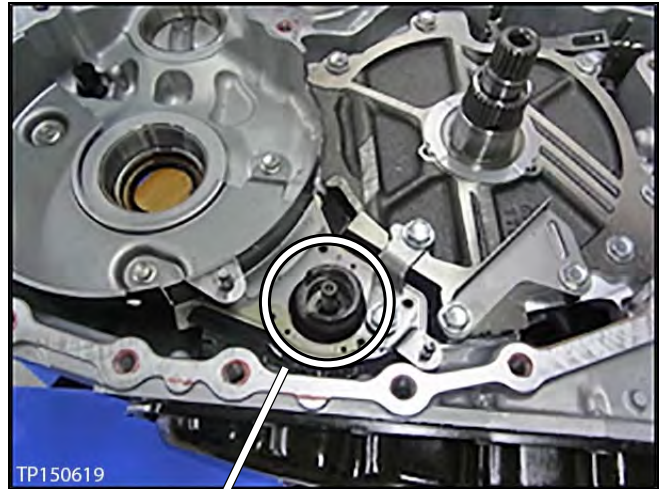

Figure 68

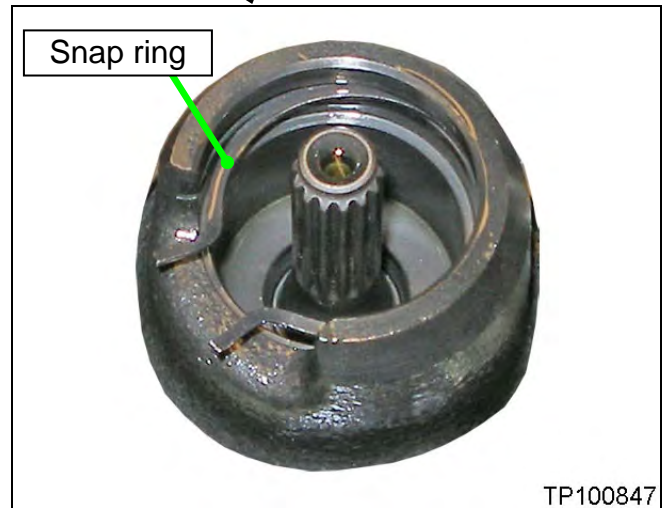

Figure 69

12. Install the existing thrust washer onto the oil pump cover (see Figure 70).

- Use petroleum jelly or equivalent to hold the thrust washer in place.
- Make sure the tabs fit into the holes.

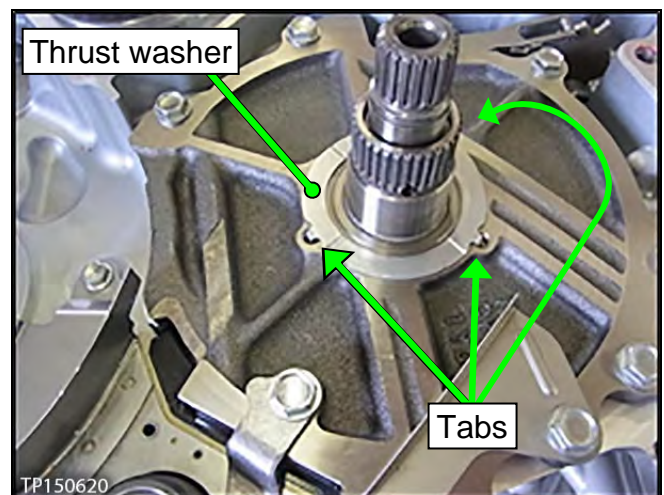

Figure 70

13. Install the drive sprocket, driven sprocket, and chain as an assembly (see Figure 71, 72, and 73).

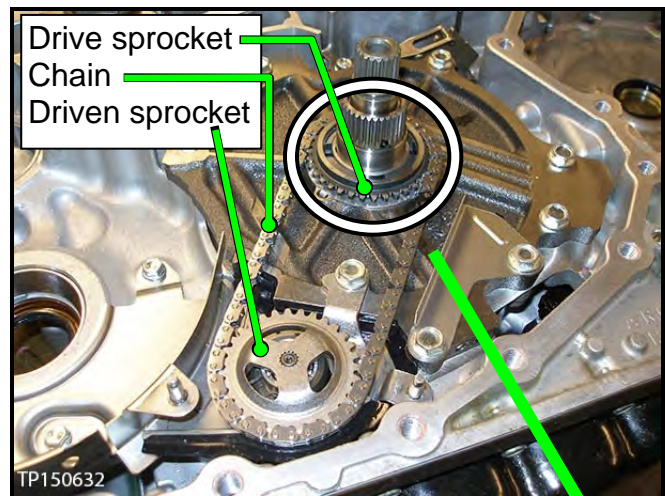

Figure 71

- Make sure the raised edge on the drive sprocket is facing up (see Figure 72).

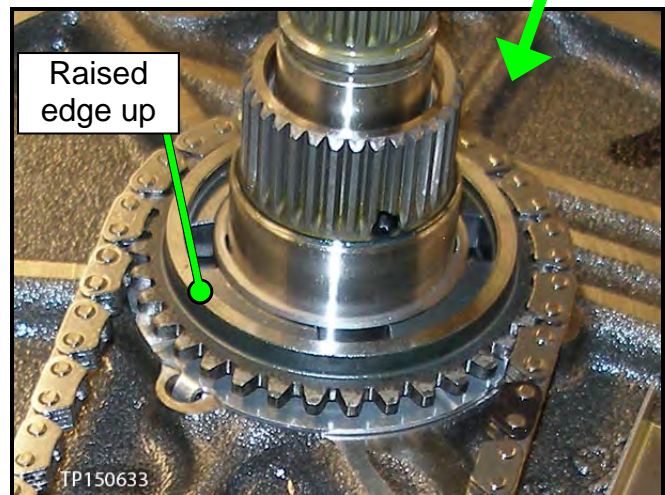

Figure 72

14. Expand the snap ring with a suitable tool, and then push down on the driven sprocket until it bottoms out (see Figure 73).

15. Release the snap ring, and then pull up on the driven sprocket until the snap ring snaps and locks in its groove.

**NOTE:** A click sound is heard when the snap ring locks in place.

**CAUTION:** Make sure the driven sprocket is locked in place.

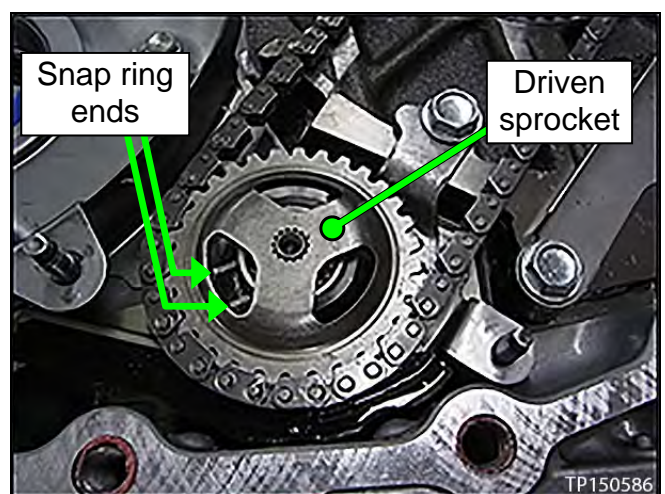

Figure 73



16. Install the first baffle plate with related nuts (see Figure 74).

- Nuts torque: 5.9 N•m (0.6 kg-m, **52.2 in lb**)

**CAUTION:** To avoid rounding off these nuts, it is best to use a 3/8 drive 6-pt 10 mm socket.

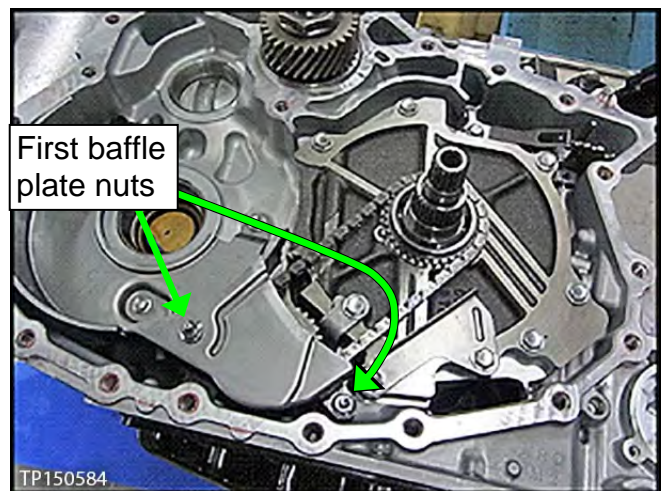

Figure 74

17. Install a new O-ring on the input shaft (see Figure 75).

- Apply CVT fluid to the O-ring and O-ring groove before installing.

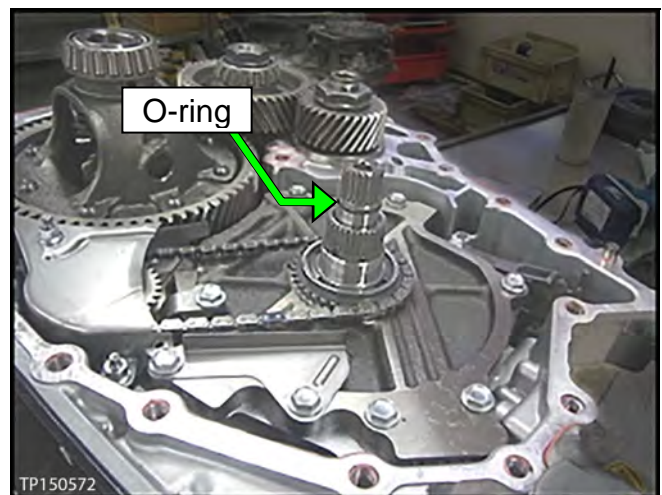

Figure 75

18. Install the differential assembly into the CVT case (see Figure 76).

**CAUTION:** Be careful not to damage gear teeth and bearings when fitting the differential assembly in place.

- Thoroughly clean the differential assembly before installing.
- Oil the bearings and gear teeth with CVT fluid before installing.



Figure 76

19. Install the new reduction gear assembly into the CVT case (see Figure 77).

**CAUTION:** Be careful not to damage gear teeth and bearings when fitting the reduction gear assembly in place.

- Make sure the reduction gear assembly is thoroughly clean before installing.
- Oil the bearings and gear teeth with CVT fluid before installing.

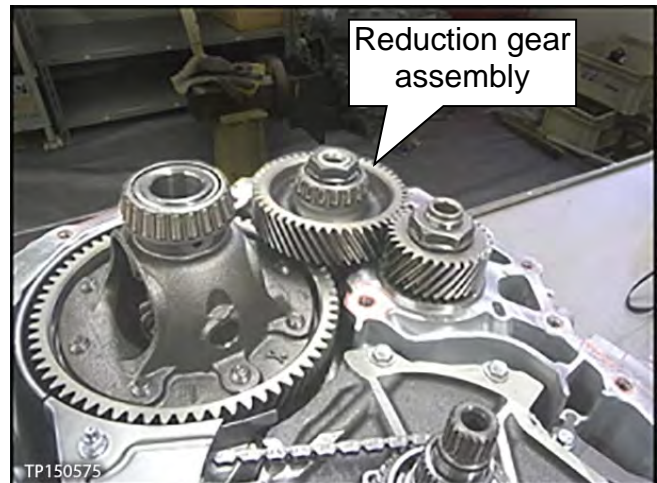

Figure 77

## Install CVT Fluid Filter and Filter cover

1. Install a new filter with grommet seal and new O-ring (see Figure 78).
  - Make sure the areas where the filter and O-ring fit are thoroughly clean.
  - Apply CVT fluid to the grommet seal and O-ring before installing.
  - Figure 78 does not show the grommet seal. It is fitted to the bottom side of the filter.

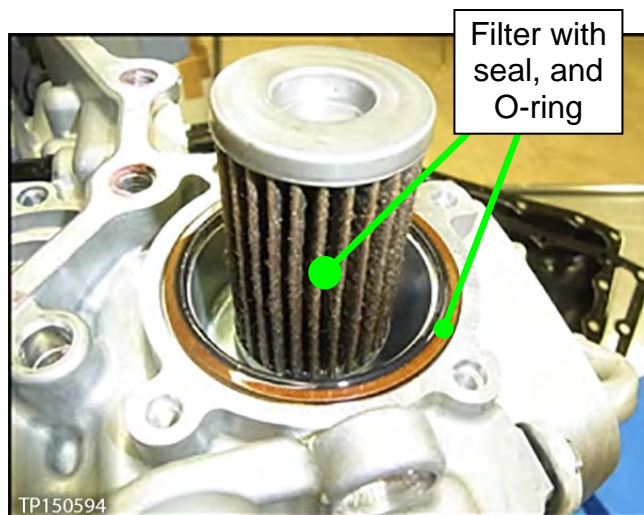

Figure 78

2. Install the filter cover (see Figure 79).
  - Make sure the filter cover is thoroughly clean on the inside before installing.
  - Filter cover bolts torque: 4.2 N•m (0.43 Kg-m, **37.2 in lb**)

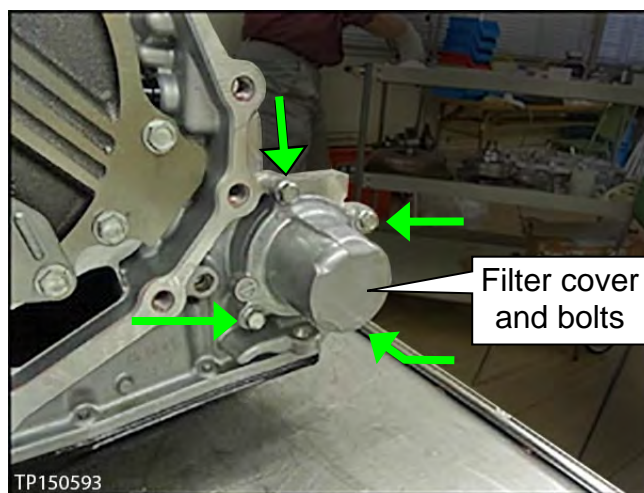

Figure 79

## Install Converter Housing to CVT Case

### IMPORTANT:

Have the converter housing ready for installation prior to applying sealant.

Before sealant application, make sure the mating surfaces are clean from oil, dirt, old sealant, etc.

**CAUTION:** Do **NOT** use sanding discs or similar abrasive tools. Use brake spray or equivalent solvent and lint-free towels only.

- Make sure the brake spray or solvents used are compatible with local regulations.

1. Apply one continuous 2.0 mm (0.08 inches) diameter bead of pink colored Loctite 5460 Sealant or equivalent (see footnote **(4)** and **(6)** in **PARTS INFORMATION**) as shown in Figure 80.

### NOTE:

- Start applying sealant where shown, making sure that the starting point and the ending point are about the middle between the bolt holes.
- Overlap both ends of the bead by 3-5 mm (0.12-0.20 inches).
- Make sure to apply sealant around the central bolt hole.

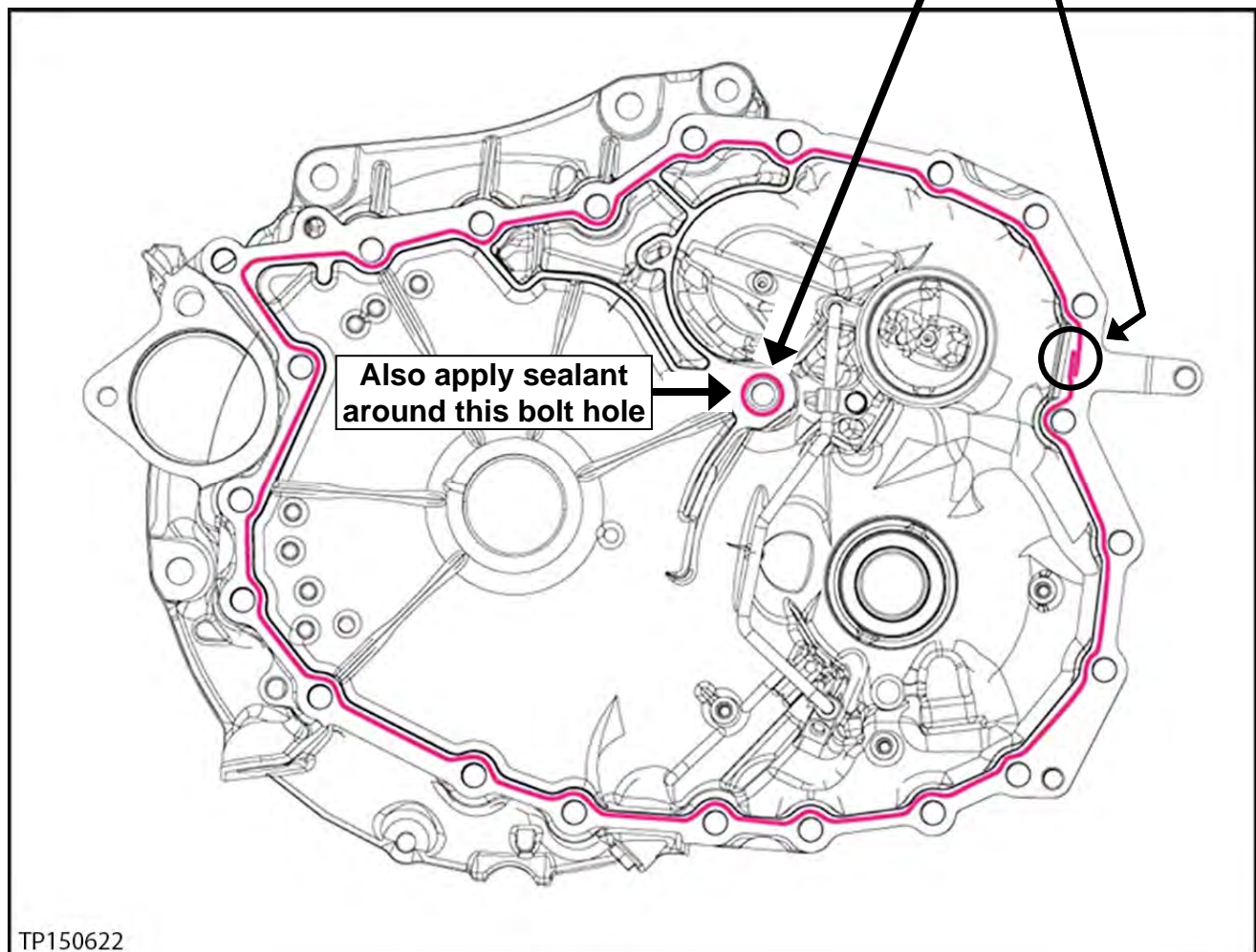



Figure 80

2. Install the converter housing onto the CVT case:

- Install new bolts from the parts kit.

a. Torque the first six (6) bolts with symbol  in numbered sequence (see Figure 81).

b. Torque the remaining bolts with symbol  in numbered sequence (see Figure 81).

- Use a short socket on the bolts indicated by this symbol: 
- All bolts are 30 mm in length.
- Bolts torque: 45.0 N•m (4.6 kg-m, **33.2 ft lb**)

**IMPORTANT:** Make sure to torque the bolts in the sequence shown in Figure 81 ONLY.

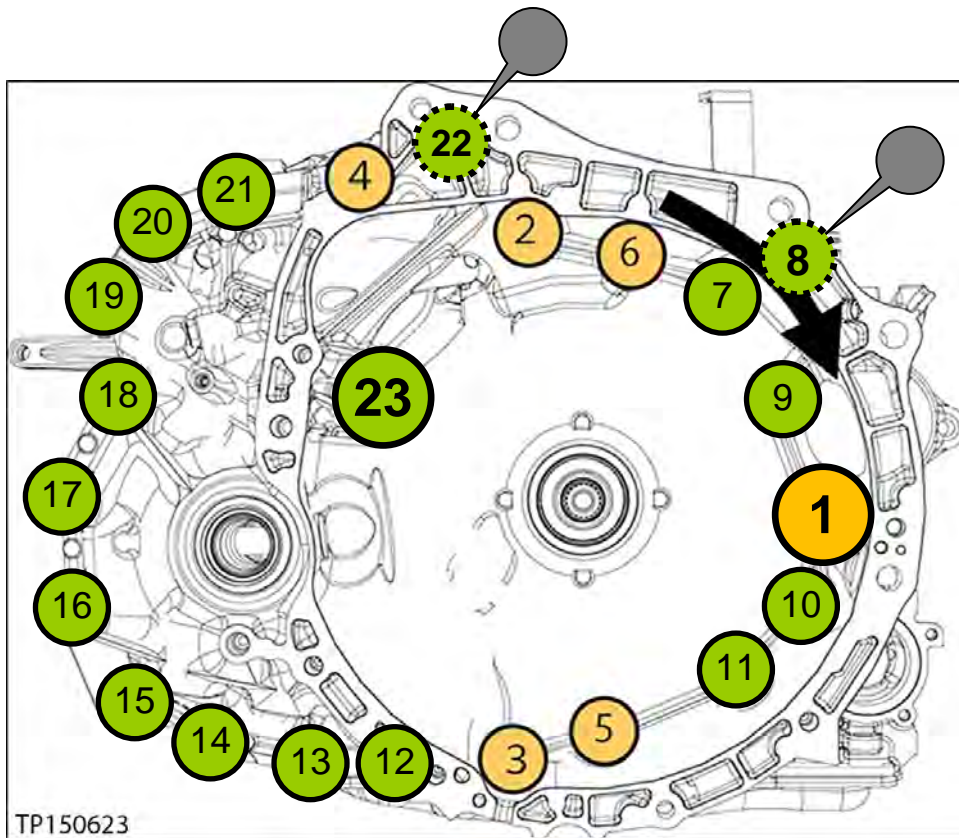

Figure 81

## Install New Control Valve Assembly (Valve Body) and Miscellaneous

**CAUTION:** Handle the valve body carefully.

1. Install a new lip seal (see Figure 82).

**NOTE:** Apply a small amount of petroleum jelly onto the lip seal to keep it in place.

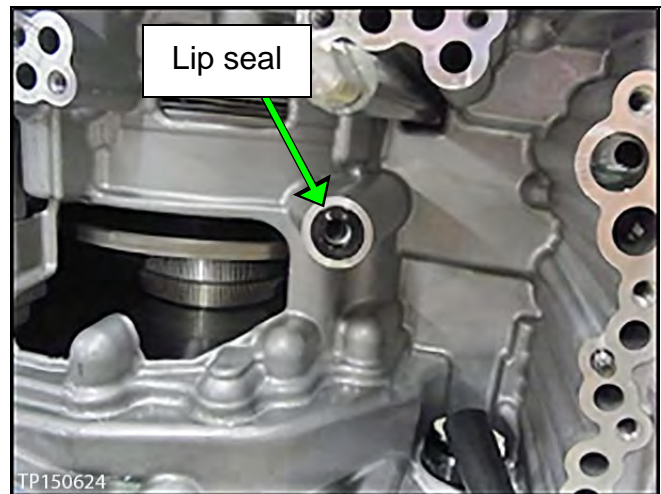

Figure 82

2. Move the wiring harness out of the way (see Figure 83).
3. Carefully put the new valve body in place, and then secure with its nine (9) mounting bolts (see Figure 83).
  - Bolts torque 8.0 N•m (0.81 Kg-m, **70.8 in lb**).

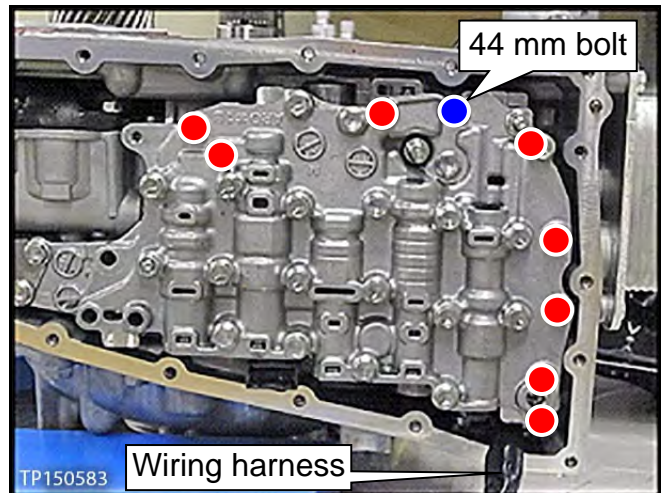

Figure 83

4. Connect the wiring harness connector (see Figure 84).

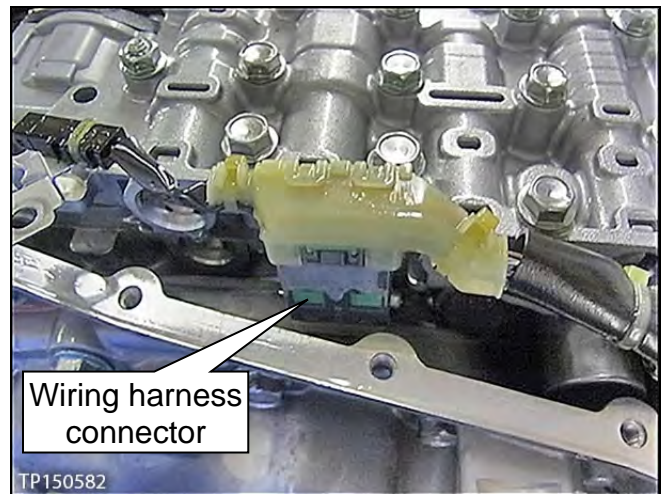

Figure 84

5. Install the oil strainer bracket with its two (2) bolts. See Figure 85.
  - Bolts torque: 8.0 N•m (0.81 Kg-m, **70.8 in lb**).
6. Install the fluid temp sensor bracket with its two (2) bolts. See Figure 85.
  - Bolts torque: 8.0 N•m (0.81 Kg-m, **70.8 in lb**).

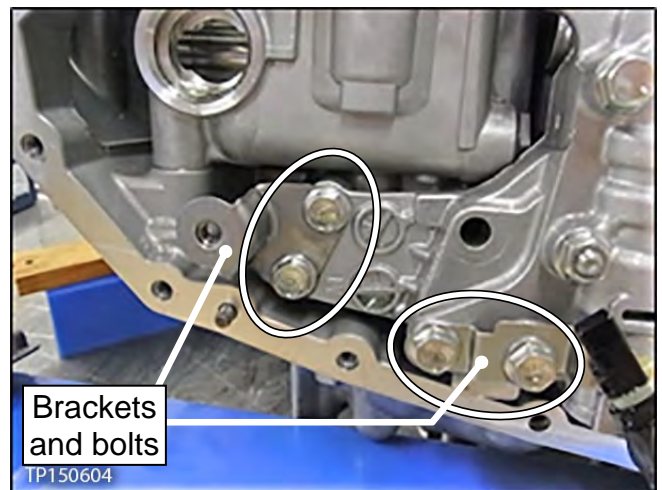

Figure 85

7. Install the new oil strainer with its new O-ring seal (see Figure 86).

- The O-ring seal cannot be seen.
- Bolts torque: 8.0 N•m (0.81 Kg-m, **70.8 in lb**).

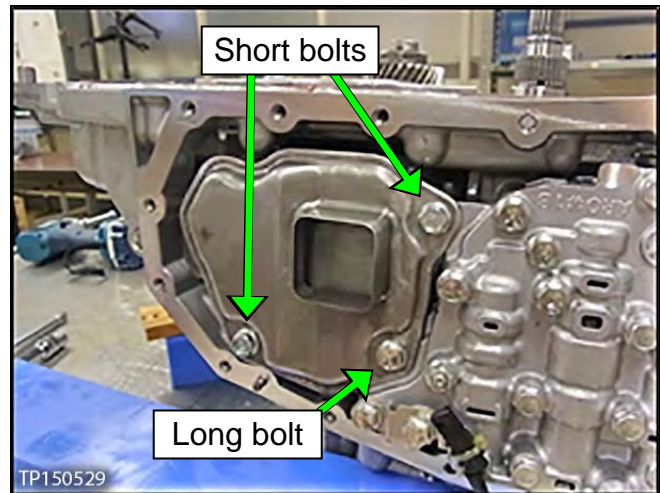

Figure 86

8. Install the manual plate, lock washer, and nut (see Figure 87).

- Reuse the existing manual plate, lock washer, and nut.
- Nut torque 22.5 N•m (2.29 Kg-m, **16.6 ft lb**).

**NOTE:** Make sure the manual plate fits into the slot of the manual valve before applying torque to the nut (see Figure 88).

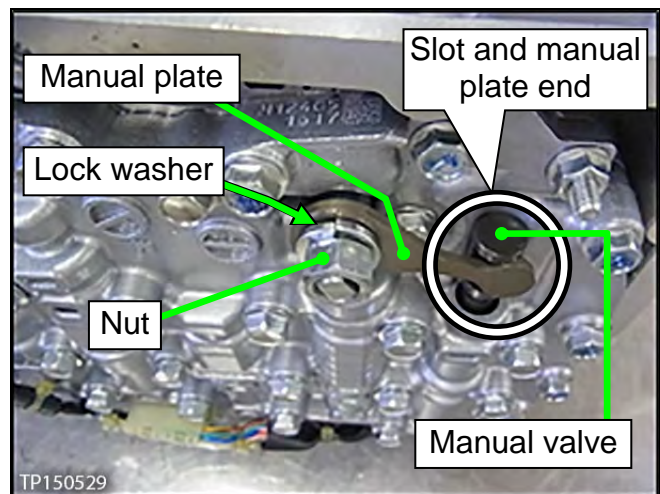

Figure 87

9. Install a new oil pan and new pan gasket (see Figure 88).

- Add a third magnet if there were only two originally.
  - A magnet is included in Kit #1 (see **PARTS INFORMATION**).
- Install the three magnets where shown in Figure 88.
- Make sure the new oil pan and all magnets are thoroughly clean before installing.

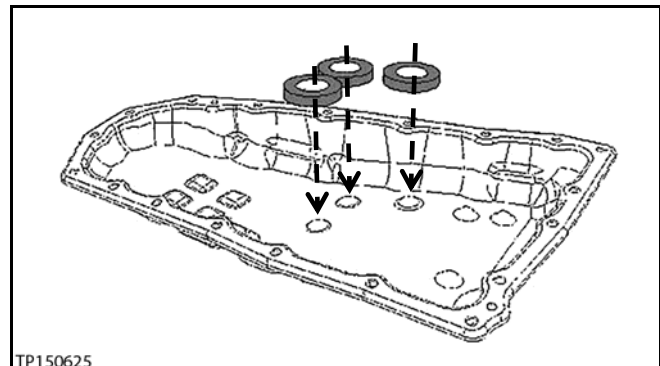

Figure 88



10. Install the oil pan bolts (see Figure 89):

- Reuse the existing pan bolts.
- Oil pan bolts torque: 8.0 N•m (0.81 kg-m, **70.8 in lb**)

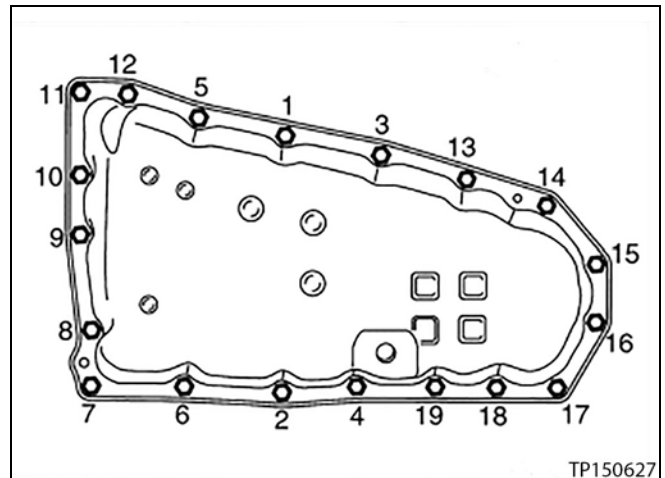

Figure 89

11. Install both differential (drive shaft) side oil seals (see Figure 90 and 91).

- Apply a light coat of CVT fluid to the seal's lip surfaces.
- For converter housing side, use Seal Installer J-50394 and Driver Handle J-8092 (see Figure 90).

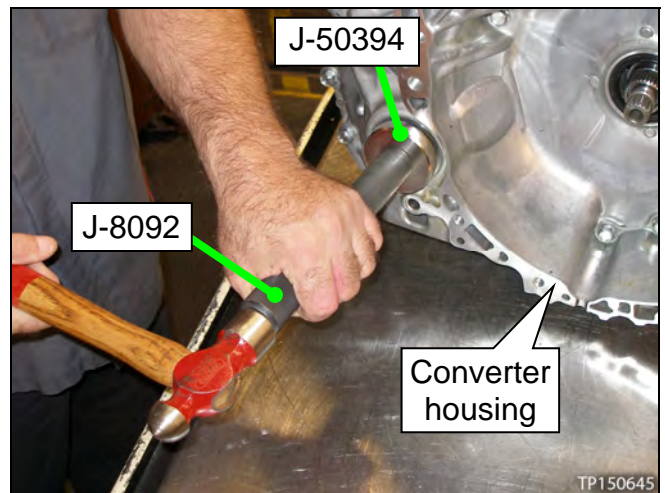

Figure 90

- For CVT case side, use Seal Installer J-50393 and Driver handle J-8092 (see Figure 91).

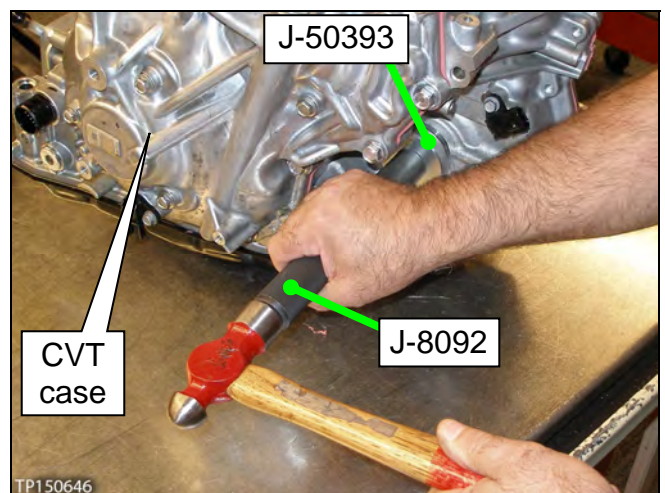
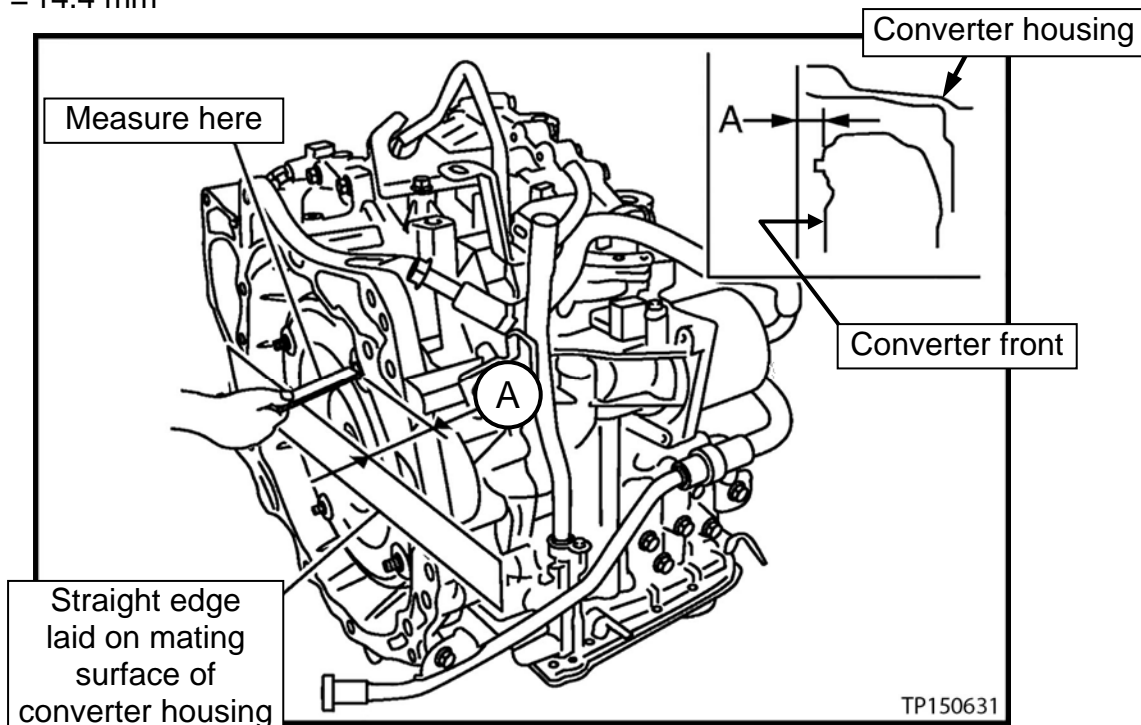

Figure 91

12. Install the torque converter.

- Verify the torque converter is installed at the proper depth (see Figure 92).
- $\textcircled{A}$  = 14.4 mm



13. Attach the QR label with the new calibration data onto the transmission range switch (inhibitor switch).

- See Figure 93 and 94 below.
- A QR Label and CD-R are included with the new valve body.

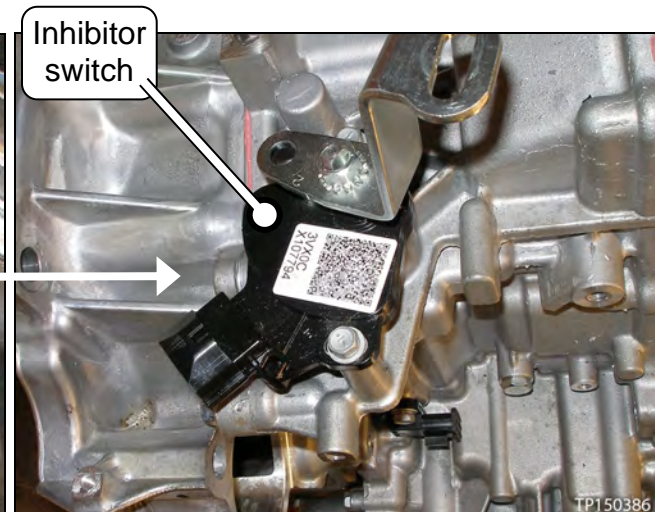
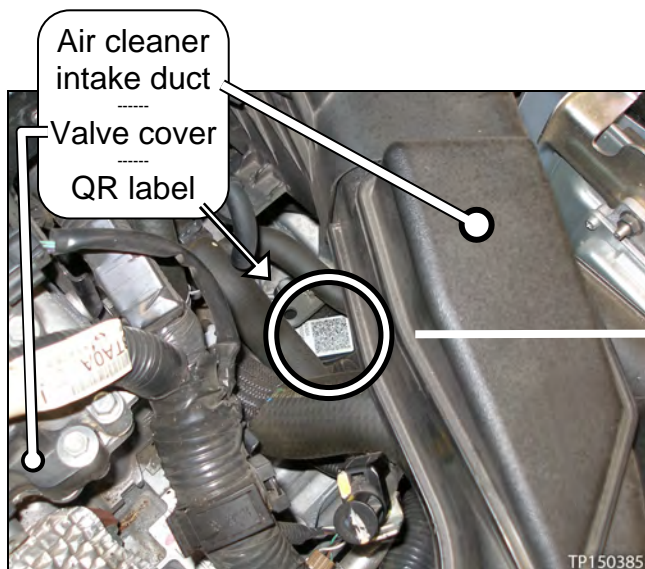

14. Install the CVT assembly (go to the next page).

## Install CVT Assembly

**NOTE:** When installing a replacement (new) CVT assembly, follow the **IMPORTANT** statement below.

**IMPORTANT:** Record a video (15 seconds maximum) of the Vehicle Identification Number (VIN) on the F.M.V.S.S. certification label (VIN label) and either no or dissimilar damage to the reduction gear bearings (page 8, step 2a) or the outer bearing race that can be moved by hand (page 8, step 3b). Attach the video to the CVT Pre-Authorization Form.

- Include showing no or dissimilar damage to the reduction gear bearings or the movement of the race by hand (whichever applies) in the video.
- The VIN label is located on the bottom of the driver side “B” pillar just inside the driver door.

1. Install the CVT assembly in the vehicle.

- Refer to the Electronic Service Manual (ESM), section **TM-Transaxle & Transmission**, for CVT installation.

2. Flush the CVT cooler.

**IMPORTANT:** A CVT Cooler flush is required after a valve body or CVT assembly replacement. Refer to bulletin NTB15-013 to perform CVT Cooler flush.

3. Connect both battery cables, negative cable last.

4. Reset / initialize all applied systems i.e., radio, power windows, clock, sunroof, etc.

- Refer to the ESM as needed.

5. **IMPORTANT:** Install Write IP Characteristics to the TCM.

- Refer to **TM – Transaxle & Transmission / RE0F10D / BASIC INSPECTION**, and perform **ADDITIONAL SERVICE WHEN REPLACING TRANSAXLE ASSEMBLY**.

6. For repaired CVTs only: perform **Flush CVT Assembly** on the next page.

- Check for fluid leakage.
- For replacement CVTs only: Do not perform a CVT flush. Go to step 7.

7. Verify the CVT operates normally and no abnormal noises are heard during a test drive.

- Vehicle repair is now complete.

## Flush CVT Assembly, Verify Repairs

**CAUTION: DO NOT USE any aftermarket transmission flushing equipment. For CVT flushing, use ONLY the procedure below.**

1. Top off the fluid level with up to four (4) quarts Nissan NS-3 CVT fluid or equivalent. See **PARTS INFORMATION**, footnote **(3)** and **(7)**.
  - Add as necessary.
2. With the vehicle still lifted on the hoist (wheels off the ground), run the engine in Drive for five (5) minutes at idle speed.
3. During step 2, verify no abnormal noise is coming from the CVT.

**IMPORTANT:** In the next step, the wheels must be braked gradually to a stop to allow proper CVT “downshift” ratio change. If this step is not performed properly, the CVT may start in an incorrect ratio.

4. After five (5) minutes, gradually brake the wheels to a stop, put in Park, turn the engine OFF, and then drain and properly discard the CVT fluid.

**WARNING:** CVT fluid will be HOT.

5. Reinstall the drain plug.
6. Repeat step 1 - 5.
7. After performing step 6, fill / top off with CVT fluid for the last time.
  - Refer to the ESM, section **TM – Transaxle & Transmission / RE0F10D**, for CVT fluid filling.
  - Drain plug torque: 34.3 N•m (3.5 kg-m, **25.3 ft lb**)
  - Fluid filler plug torque: 10.0 N•m (1.0 kg-m, **89 in lb**)
8. Go back to the previous page, step 7.

## PARTS INFORMATION

DESCRIPTION	PART #	QUANTITY
CVT ASSEMBLY	(1)	1 (2)
GEAR ASSY-REDUCTION PINION (Kit #1)	31490-3VX8D	1
PUMP ASSY-OIL (Kit #2)	31340-28X8A	1
SHIM ADJUST (Kit #3)	31499-28X8A	(5)
CONTROL VALVE (valve body) (8)	31705-28X0B	1
Nissan NS-3 CVT Fluid (3) (7)	999MP-NS300P	As needed
Loctite 5460 Sealant (3)	999MP-LT5460P	(4) (6)
WASHER-DRAIN (for drain plug)	11026-01M02	1
SEAL-O RING (for fluid filler plug)	31526-3VX0B	1

(1) Refer to your Electronic Parts Catalog (FAST or equivalent) for the correct part number.

(2) The CVT is to be replaced only when the existing CVT cannot be repaired.

(3) Nissan NS-3 CVT Fluid and Loctite 5460 Sealant can be ordered through the Nissan Maintenance Advantage program: Phone: 877-NIS-NMA1 (877-647-6621) or Website: Order via link on dealer portal [www.NNAnet.com](http://www.NNAnet.com) and click on the "Maintenance Advantage" link.

(4) One container of Loctite 5460 Sealant is good for approximately 10 repairs.

(5) Shim Adjust Kit #3 is for dealer stock **only**. Shim Adjust Kit #3 contains an assortment of shims that are commonly required to make this repair. Charge out the individual shim(s) needed for each repair only. Reorder only the shim(s) replaced as it is not necessary to reorder Shim Adjust Kit #3.

(6) Bill out Loctite 5460 Sealant under **expense code 008**. Do not include the Loctite 5460 Sealant part number on the claim.

(7) For warranty repairs, Nissan NS-3 CVT Fluid **must** be used. For customer pay repairs, Nissan NS-3 CVT Fluid or an equivalent is recommended.

(8) Includes QR label, CD-R, and control valve assembly.

Go to the next page for shim part numbers.

DESCRIPTION	PART #: 31438-	QTY	DESCRIPTION	PART #: 31499-	QTY
SHIM ADJUST (shim)	8E000 *	**	SHIM ADJUST (shim)	28X0A	**
	8E001 *			28X0B	
	8E002 *			28X0C	
	8E003 *			28X0D	
	8E004 *			28X0E	
	8E005 *			28X1A	
	8E006 *			28X1B	
	8E007 *			28X1C	
	8E008 *			28X1D *	
	8E009 *			28X1E *	
	8E010			28X2A *	
	8E011			28X2B *	
	8E012			28X2C *	
	8E013			28X2D *	
	8E014			28X2E *	
	8E015			28X3A *	
	8E016			28X3B *	
	8E017			28X3C *	
-	28X3D *				

\* These individual shims are not included in Shim Adjust Kit #3 and must be ordered separately. They are seldom used and are not stocked in large quantities at Nissan PDCs. For these reasons, it is not necessary nor recommended to order these shims for dealer stock.

\*\* As needed.



Kit #1



Kit #2



Repair Kit #3

**CLAIMS INFORMATION**

If CVT Assembly is replaced

**Submit a Primary Part (PP) type line claim using the following claims coding:**

DESCRIPTION	PFP	OP CODE	SYM	DIA	FRT
CVT R&R	(1)	JD01AA JD023A	ZE	32	(2)
CVT Trouble diagnosis		JX22AA			0.5
Inspect bearing - No bearing damage		JX43AA			0.5

- (1) Reference the electronic Parts Catalog (FAST or equivalent) and use the CVT assembly part number for the vehicle being repaired as the Primary Failed Part.
- (2) Reference the current Nissan Warranty Flat Rate Manual and use the indicated Flat Rate Time.

Or

If reduction bearing is replaced

**Submit a Primary Part (PP) type line claim using the following claims coding:**

DESCRIPTION	PFP	OP CODE	SYM	DIA	FRT
CVT R&R	(1)	JD01AA JD023A	ZE	32	(2)
CVT Trouble diagnosis		JX22AA			0.5
Inspect Bearing and replace reduction gear assembly		JX42AA			2.9

- (1) Reference the electronic Parts Catalog (FAST or equivalent) and use the CVT assembly part number for the vehicle being repaired as the Primary Failed Part.
- (2) Reference the current Nissan Warranty Flat Rate Manual and use the indicated Flat Rate Time.

**Expense code:**

EXPENSE CODE	DESCRIPTION	MAX AMOUNT
008	Sealant	\$6.23