



SERVICE BULLETIN

Classification: RA21-002	Reference: NTB21-045	Date: May 25, 2021
-----------------------------	-------------------------	-----------------------

2013-2018 ALTIMA AND 2016-2018 MAXIMA; REAR SUSPENSION LOWER LINK

APPLIED VEHICLES: 2013-2018 Altima (L33)
2016-2018 Maxima (A36)

IF YOU CONFIRM

The customer experiences a knocking or rattling noise from the rear of the vehicle,

Or

The rear wheel and tire assemblies have a large amount of positive camber.

ACTION

Replace both rear lower links.

IMPORTANT: The purpose of ACTION (above) is to give you a quick idea of the work you will be performing. You **MUST** closely follow the entire SERVICE PROCEDURE as it contains information that is essential to successfully completing this repair.

Nissan Bulletins are intended for use by qualified technicians, not 'do-it-yourselfers'. Qualified technicians are properly trained individuals who have the equipment, tools, safety instruction, and know-how to do a job properly and safely. **NOTE:** If you believe that a described condition may apply to a particular vehicle, **DO NOT** assume that it does. See your Nissan dealer to determine if this applies to your vehicle.

REQUIRED SPECIAL TOOL

Each dealer has been shipped one Coil Spring Compressor, special tool J-52929.

Additional tools are available from Tech•Mate online: www.nissantechmate.com, or by phone: 1-800-662-2001.

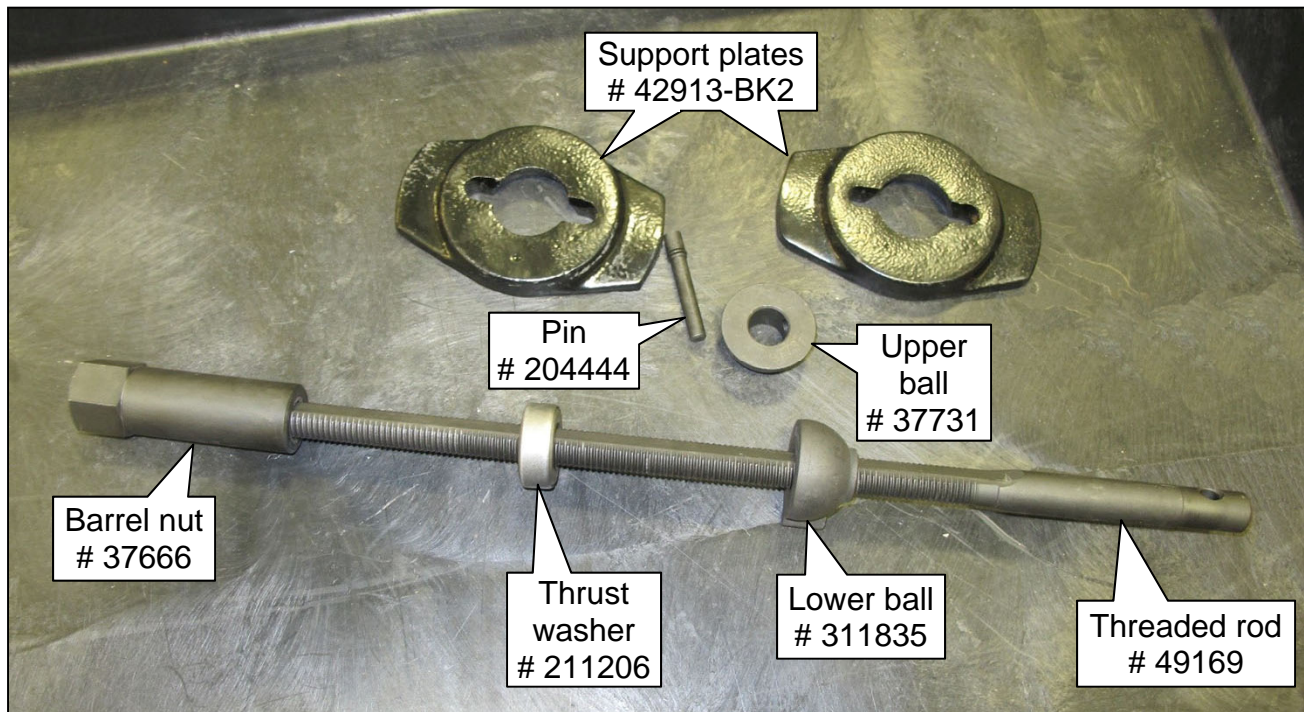

Figure 1

⚠ WARNING

- When using the spring compressor, wear proper eye protection. Dirt or debris may enter the eye, causing injury.
- Inspect the condition of the spring compressor before each use. Do not use the spring compressor if it is not in serviceable condition. Injury may occur when parts are bent, cracked, etc.
- Do not drop the spring compressor when it is holding a compressed spring. If dropped, the spring may separate from the spring compressor and launch toward your body, causing injury.

SERVICE PROCEDURE

HINT: Most of the **SERVICE PROCEDURE** will show a repair performed on the left rear side. The same repair will be repeated on the right rear side.

1. Place the vehicle on a lift and raise to a suitable height to remove both rear wheel and tire assemblies from the vehicle.
2. Mark the suspension alignment washer to the frame on all 4 rear lower link alignment bolts (see Figure 2).

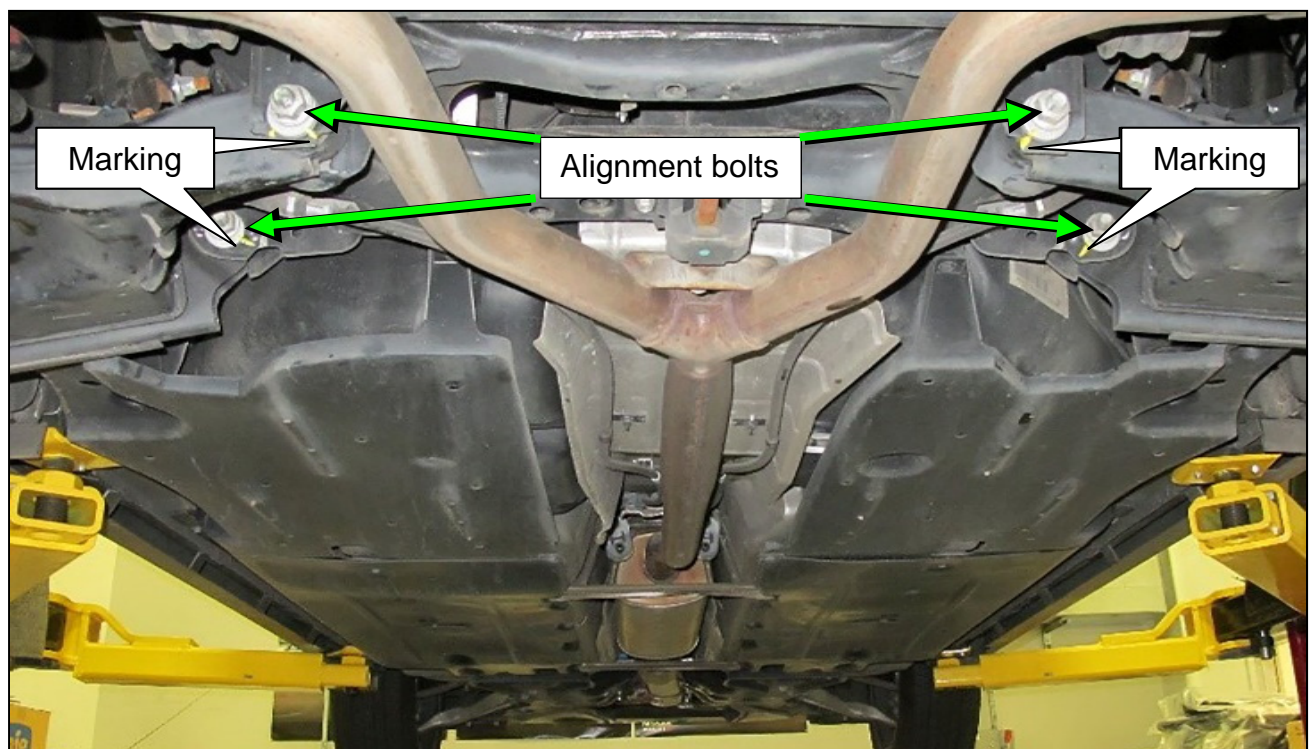

Figure 2

3. Install the upper ball in the cavity of a support plate of special tool J-52929, upper ball facing upward, and then place the support plate midway inside the coil spring.

HINT: The upper ball can be identified by its cross drilled pin hole.

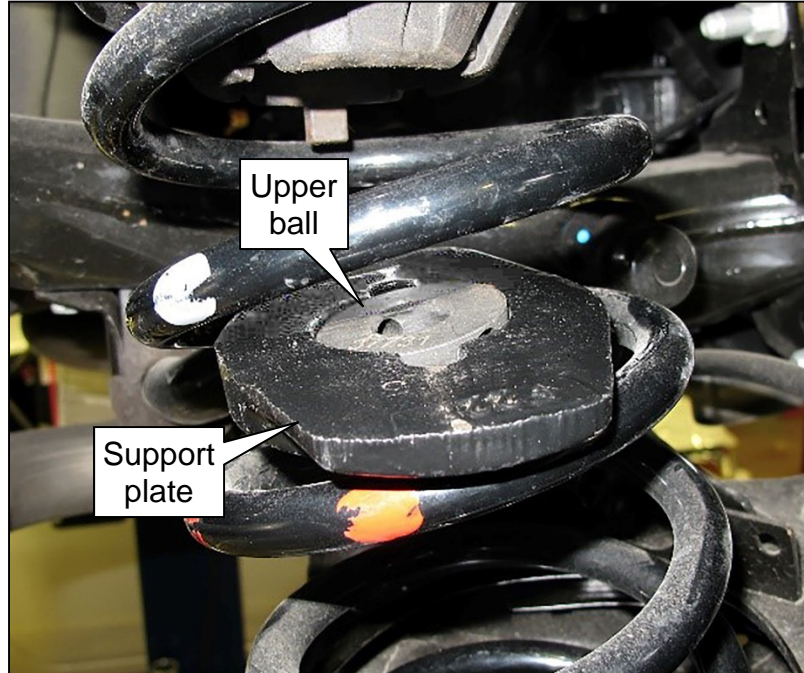

Figure 3

4. Install the other support plate, with the ball cavity facing down, as low as possible inside the coil spring.

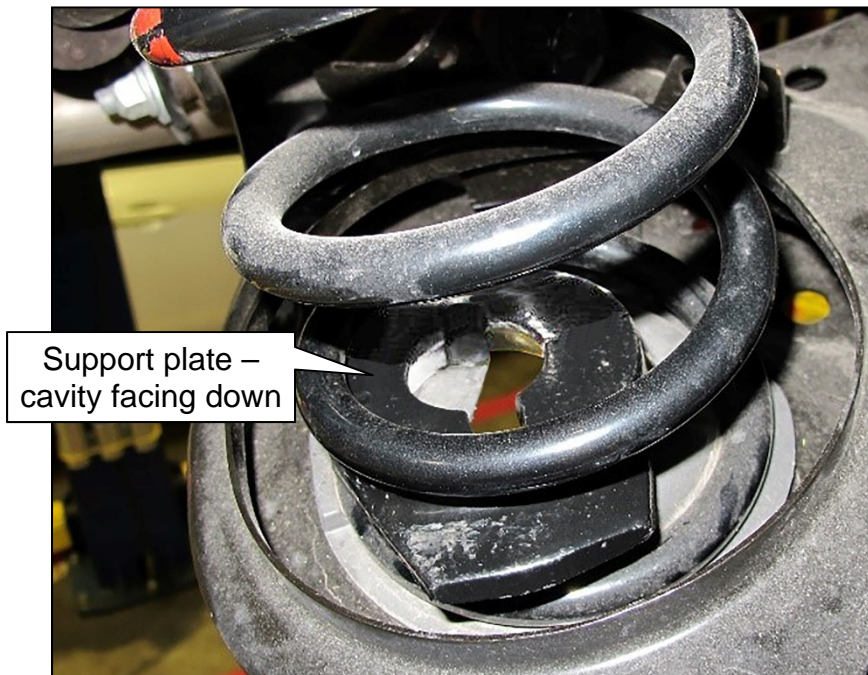

Figure 4

5. Assemble special tool J-52929 as shown in Figure 5.
 - To keep the pieces together, thread the barrel nut onto the threaded rod.



Figure 5

6. Install the assembled pieces, pin hole end first, from the bottom of the coil spring through both support plates and the upper ball.



Figure 6

7. Install the pin of special tool J-52929 through the upper ball and threaded rod up to its O-ring stopper.

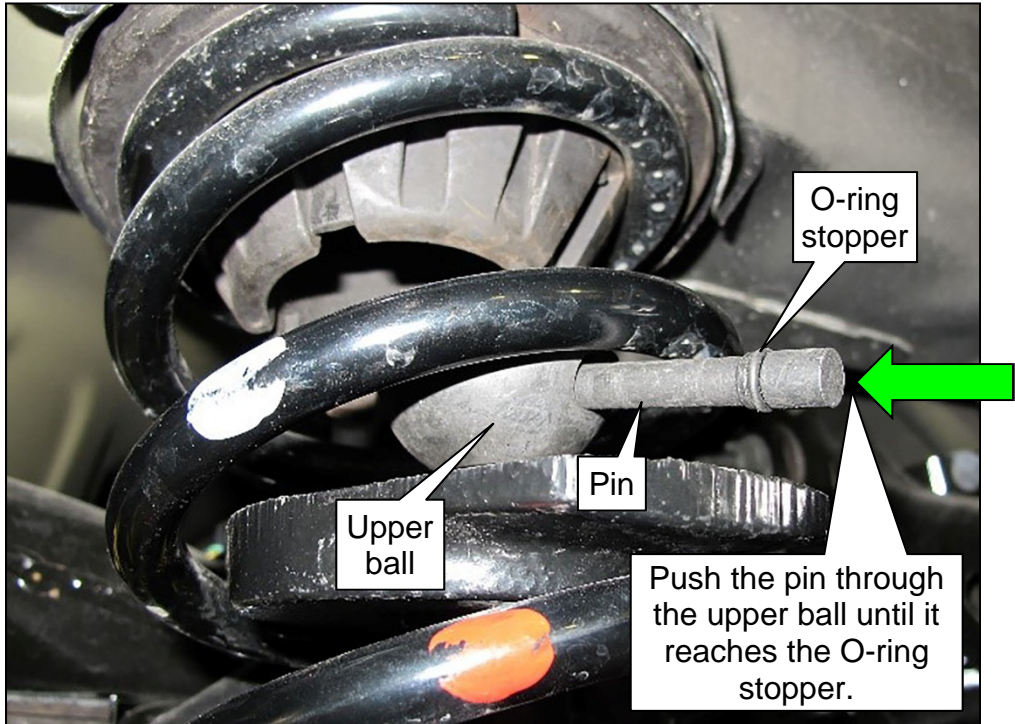

Figure 7

8. Align the upper ball into the upper support plate cavity so that the pin rests in the slots.

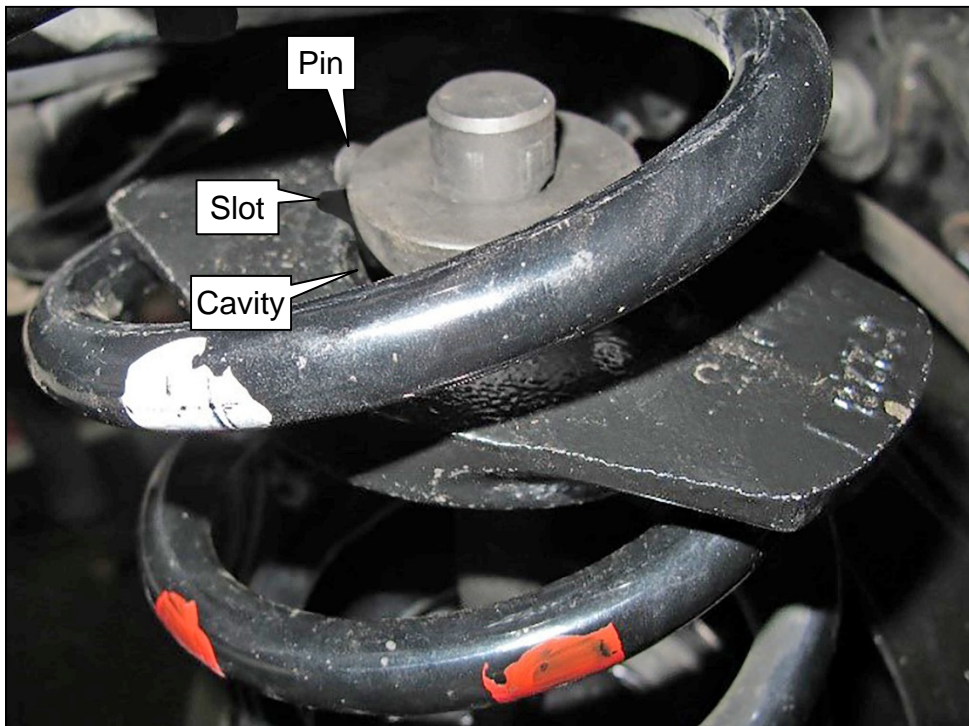

Figure 8

9. Rotate the threaded rod and upper support plate together, as an assembly, counterclockwise until the upper support plate contacts the upper rubber seat.

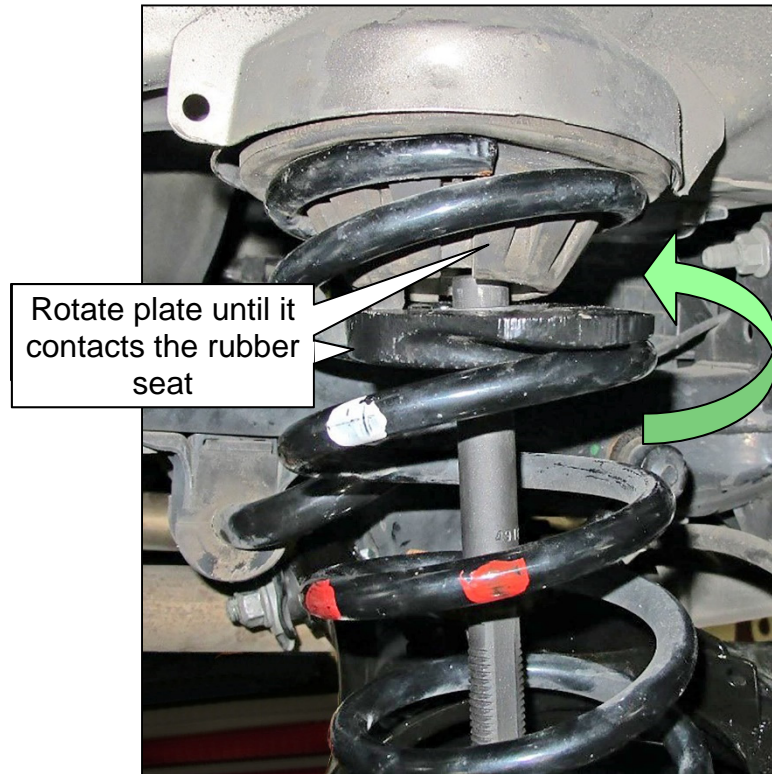

Figure 9

10. Slide the lower ball up the rod and into the lower support plate cavity, while aligning the lower ball's notch into one of the lower support plate's slots.
 - Make sure the lower plate stays as low on the coil spring as possible.
11. Thread the barrel nut up the threaded rod until the thrust washer makes contact with the lower ball (see Figure 10).

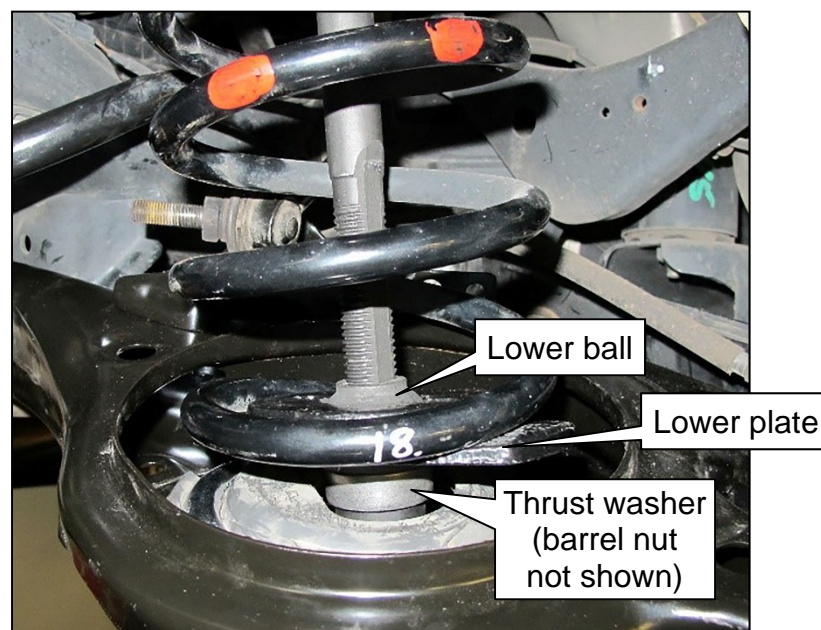

Figure 10

12. Compress the coil spring until the lower ball bottoms out on the threaded rod.
 - To compress the coil spring, use a wrench, deep socket, or other suitable tool to turn the barrel nut clockwise.



Figure 11

13. Remove the 2 knuckle bolt nuts and the 2 alignment bolt nuts, but do NOT remove the related bolts at this time.

NOTE: These nuts will not be reused and will be replaced with new ones.

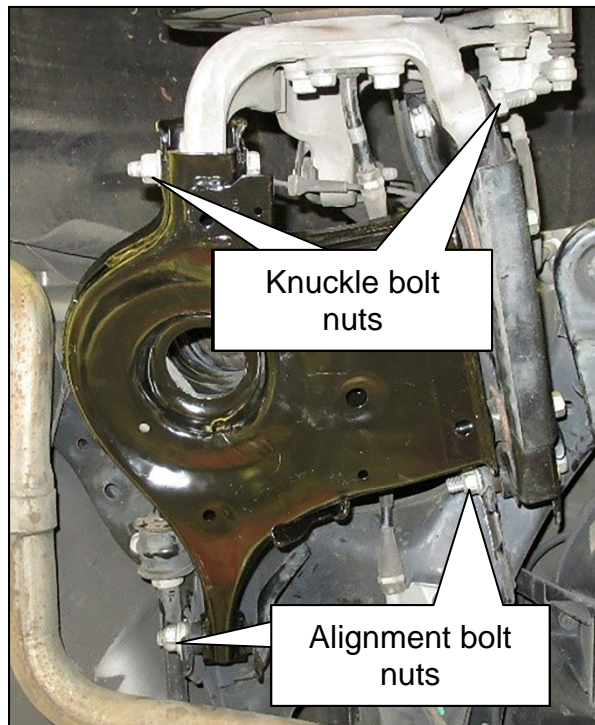

Figure 12

14. Remove the nut holding the rear stabilizer connecting rod to the rear lower link.

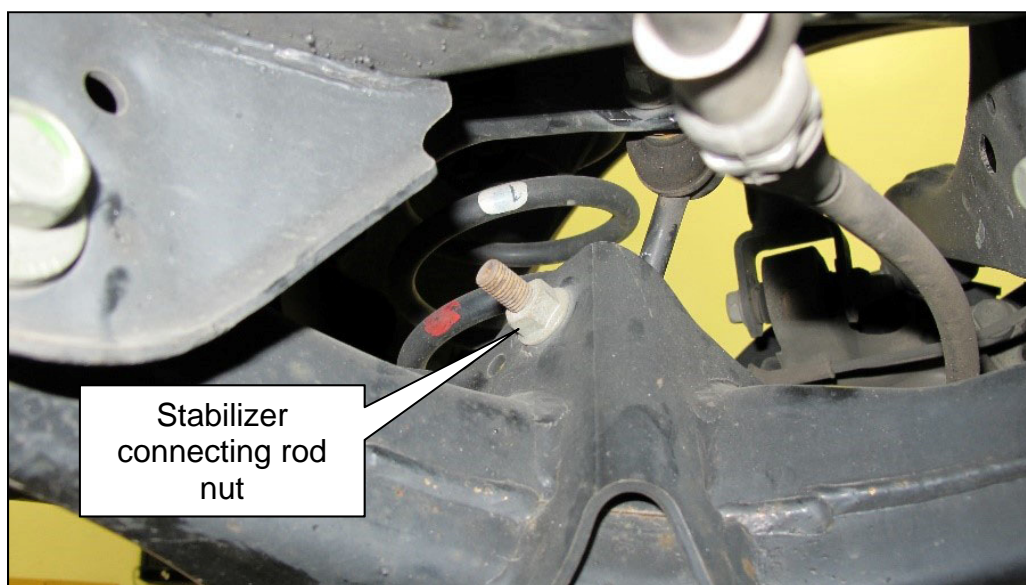

Figure 13

15. Remove the coil spring and special tool J-52929 as an assembly:
 - a. Remove both inside rear lower link (alignment) bolts.

HINT: Due to being marked earlier, these bolts need to go back to their original locations during reassembly.
 - b. Swing the rear lower link downward.
 - c. Remove the connecting rod assembly from the rear lower link.
 - d. Remove the coil spring and special tool J-52929 as an assembly.

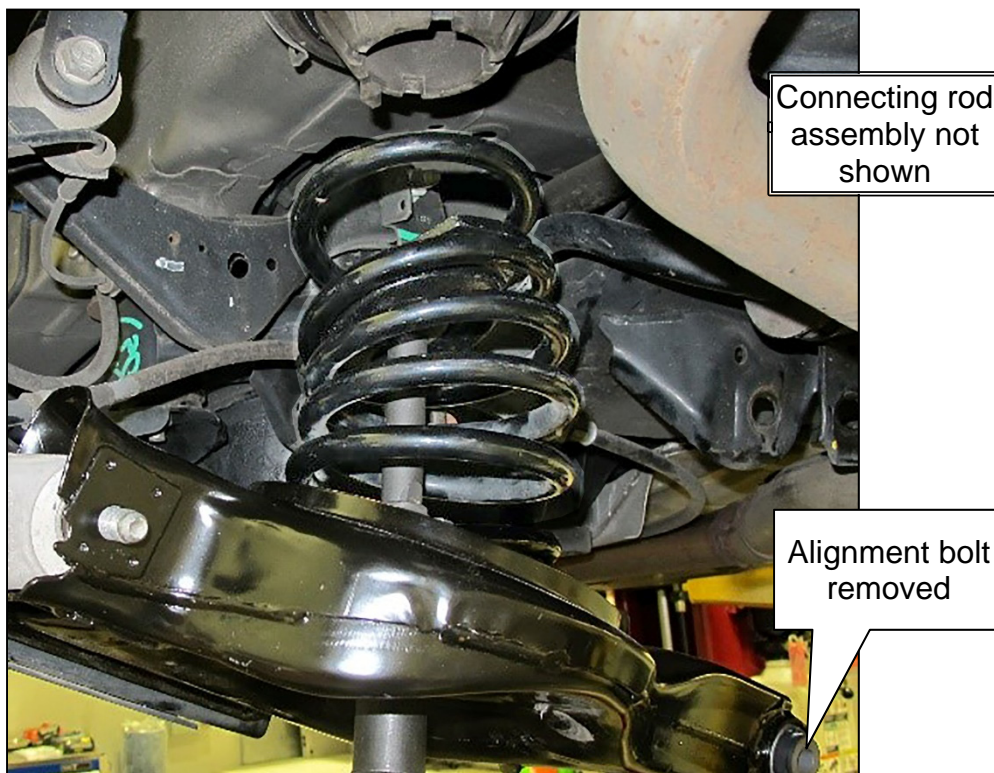

Figure 14

16. Remove the 2 remaining knuckle bolts, and then remove the rear lower link from the vehicle.

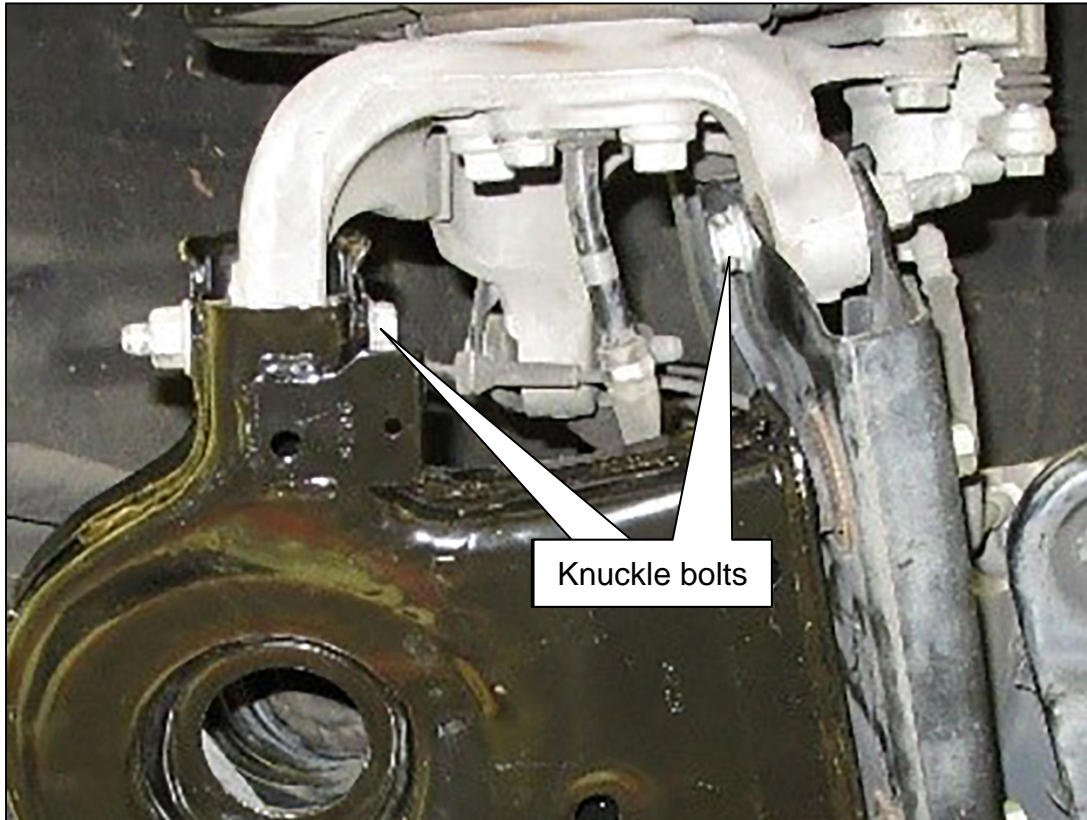

Figure 15

17. Remove the 2 bolts, and then remove the front lower link from the rear lower link.

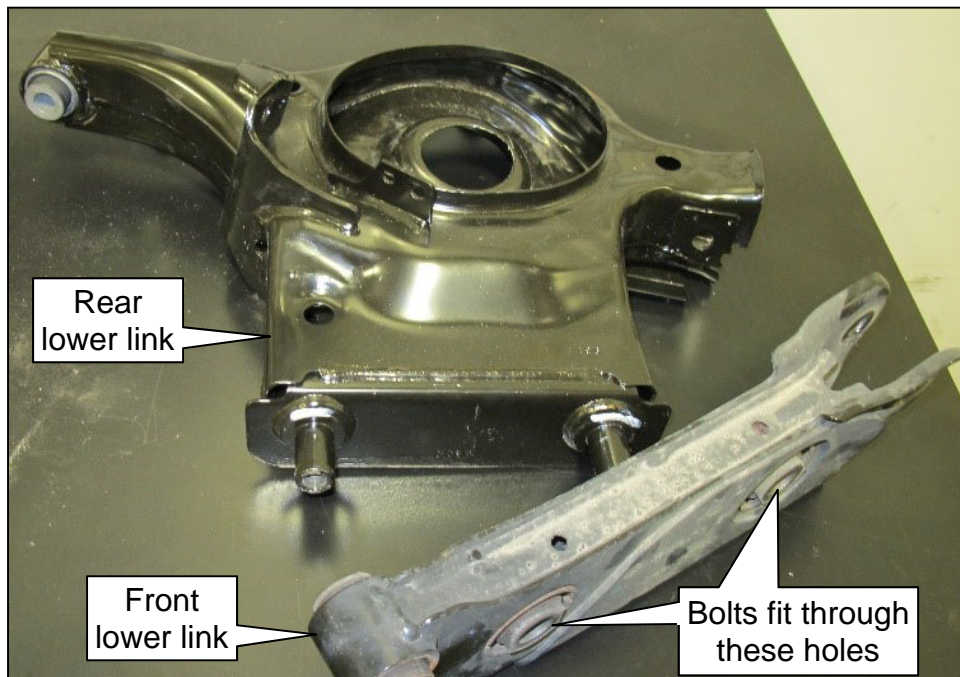

Figure 16

18. Install a new rear lower link in the reverse order of disassembly.

- Transfer the lower rubber seat from the old rear lower link to the new rear lower link.

HINT: To make reassembly of the front and rear lower links easier, hand tighten the bolts, and then back off by 2 turns. This will allow for extra movement of these parts.

- Tighten all fasteners from step 18 through step 19 to the specified torque with the vehicle unladen and the weight of the vehicle on the ground.

HINT: A drive-on lift will make it easier to tighten fasteners to correct torque.

- Front lower link-to-rear lower link bolt torque: 111 N•m (11 kg-m, **82 ft-lbs**)
- Rear stabilizer connecting rod nut torque: 44 N•m (4.5 kg-m, **32 ft-lbs**)
- Nut-to-alignment bolt torque: 146 N•m (15 kg-m, **108 ft-lb**)

HINT: Place the alignment bolts in their original locations, and then line up the marks when tightening to specified torque.

- Nut-to-knuckle bolt torque: 118 N•m (12 kg-m, **87 ft-lbs**)
- When installing the coil spring (still compressed):
 - a. Make sure the orientation of the coil spring is as shown in Figure 17: A single painted mark is above the two painted marks.

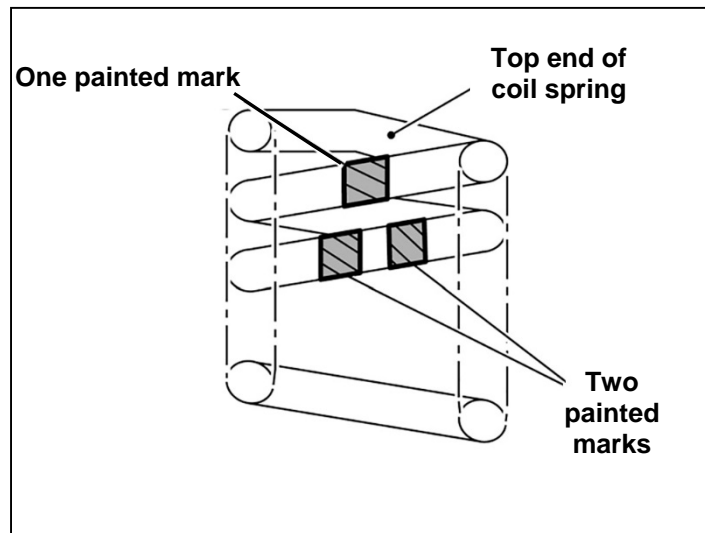

Figure 17

- b. Make sure the upper rubber seat is secured to the bracket, which is secured to the vehicle.
- Make sure the protrusion is aligned, facing into the vehicle.

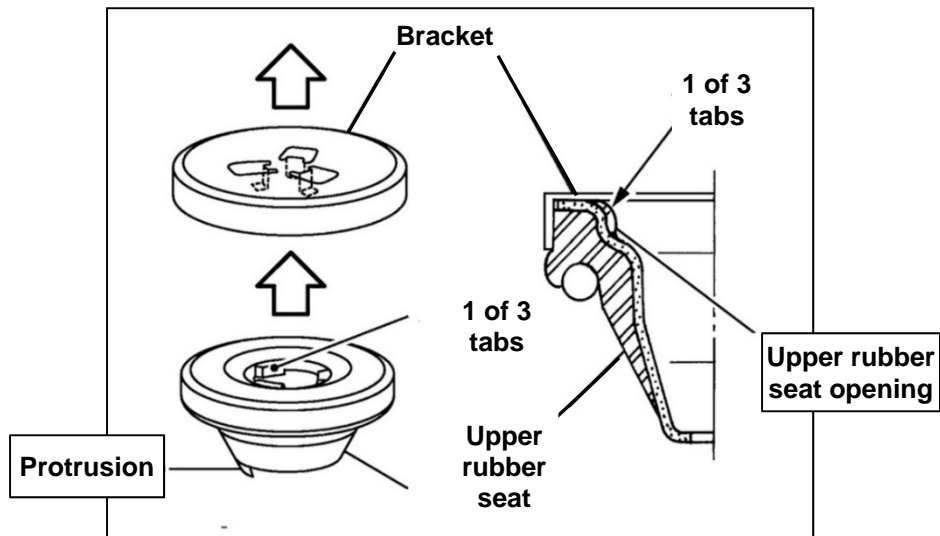

Figure 18

- c. Align the coil spring by placing its lower end as shown in Figure 19.

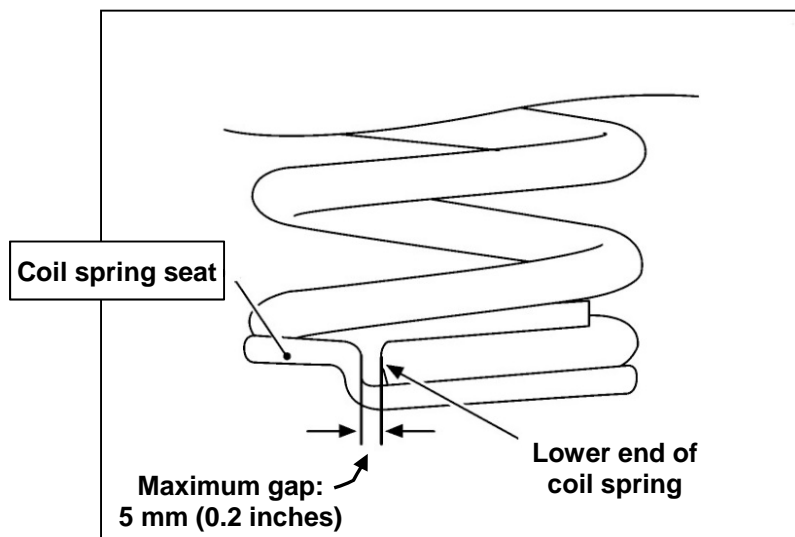

Figure 19

19. Perform steps 3-18 on the other rear lower link.
20. Reinstall both rear wheel and tire assemblies.
 - Wheel lug nut torque: 113 N•m (12 kg-m, **83 ft-lbs**)
21. Perform a 4-wheel alignment.
22. Reset the steering angle sensor (neutral position adjustment) with C-III plus.

PARTS INFORMATION

DESCRIPTION	PART NUMBER	QUANTITY
Rear Suspension Lower Link - RH	551B0-3TA0D	1
Rear Suspension Lower Link - LH	551B1-3TA0D	1
Nut (Alignment)	54588-JA060	4
Bolt (Knuckle)	56280-JA00C	4
Nut (Knuckle)	40262-JA000	4

CLAIMS INFORMATION

Submit a Primary Part (PP) type line claim using the following claims coding:

DESCRIPTION	PFP	OP CODE	SYM	DIA	FRT
Remove and Install Both Rear Lower Link Assemblies	(1)	NX29AA	ZE	32	2.7

- (1) Reference the electronic parts catalog and use the Lower Suspension Link as the Primary Failed Part (PFP).

NOTE: FRT includes alignment; no other alignment op code is required. DO NOT claim the alignment op code with this claim.

AMENDMENT HISTORY

PUBLISHED DATE	REFERENCE	DESCRIPTION
May 25, 2021	NTB21-045	Original bulletin published