

REFERENCE:	Nova Bus Manuals
SECTION:	12: Seats
RS N°:	MQR 7621-2093
EFFECTIVE IN PROD.:	LD38 (2020OC)

APPLICATION DEADLINE: 2022JL01
CLAIM REFERENCE NUMBER: WB-5029

SUBJECT:	Flip-up seats
JUSTIFICATION:	The premature failure of the grommet causes the seat backs to become loose.

LEVEL	DESCRIPTION	DIRECT CHARGES		TIME
		LABOUR	MATERIAL	
1	Replace the two side plates by a wider plate and add rubber bumpers between the back plate and the mounting bracket.	Nova Bus	Nova Bus	6min
2	–	–	–	–

MATERIAL

QTY	PART N°	REV.	DESCRIPTION	REPLACES PART N°
LEVEL 1				
2	N8950638-BS	–	Kit, American Seating	–
LEVEL 2				
–	–	–	–	–

Materials will be available within 32 days once your order has been placed. To order, please contact Prevost Parts by phone at 1-800-771-6682, by fax at 1-888-668-2555 or by email at prevostparts.commandes@volvo.com. Specify document number, quantity of parts required and shipping address.

DISPOSAL OF PARTS

REMOVED PARTS ARE:	DISCARDED *	RETAINED	* Dispose of the unused parts and the defective parts in accordance with local environmental standards in effect.
	Yes	–	

REVISION HISTORY

REV.	DATE	CHANGE DESCRIPTION	WRITTEN BY
NR	2021MA27	Initial release	André Pelletier

APPROVED BY:

PAGE 1 OF 5

CLIENT	ORDER	ROAD NUMBER		VIN (2NVY/4RKY...)		QTY
		FROM	TO	FROM	TO	
CHARM city Baltimore - Maryland	LC73	1910218	1910223	L82J4K9777447	L82J8K9777452	6

**WARNING**

Follow your internal safety procedures.

PROCEDURE

- 1.1. Park the vehicle on an even surface with the transmission on neutral.
- 1.2. Apply the parking brake and set the master control switch to the **stop** position.
- 1.3. Follow the supplier's procedure to replace the 2 flip-up seats back plate.

**NOTE**

The following procedure is provided by American Seating. Nova Bus cannot be held responsible for its content.



CHANGE BACK PLATE ON BC55

FMI – BC55 0008

PROCESS DESCRIPTION	REVISION	ISSUE DATE	M.E./AUTHOR	APPROVER
CHANGE BACK PLATE	A	12/16/2020	DAWN ESTALIS	TOM WARD

STEP 1	STEP 2	STEP 3
REMOVE BACK FROM BC55 SEAT AND PLACE ON FLAT WORK SURFACE	REMOVE 2 BOLTS (005730402401) SECURING PLATE (153291002), RETAIN FOR RE-ASSEMBLY	DISCARD 2 RUBBER GROMMETS (153117000) AND 2 NYLON WASHERS (031339030)

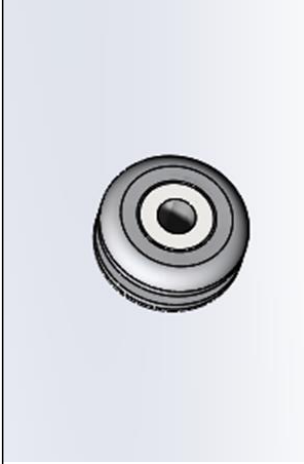
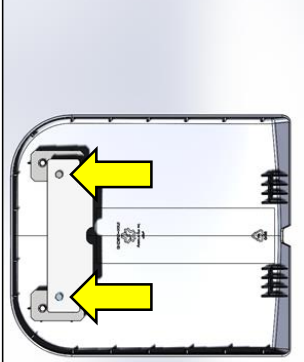
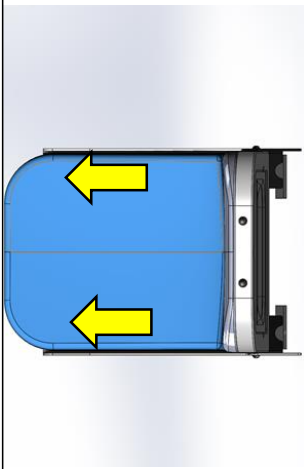

USE A 7/16" SOCKET

STEP 4	STEP 5	STEP 6
RETAIN 2 SPACERS (023436307) FROM UNDER RUBBER GROMMETS/NYLON WASHERS	REMOVE FOUR BOLTS (151088001) AND TWO PLATES (162072). RETAIN THE BOLTS FOR RE-ASSEMBLY	ASSEMBLE NEW PLATE WITH ATTACHED BUMPERS (162581000) WITH FOUR BOLTS (151088001) RETAINED FROM STEP 5

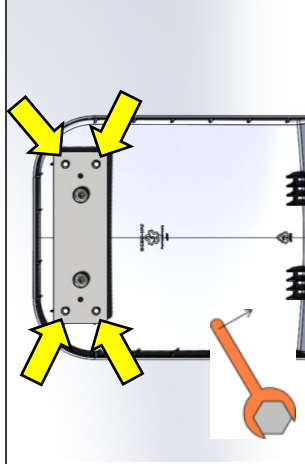
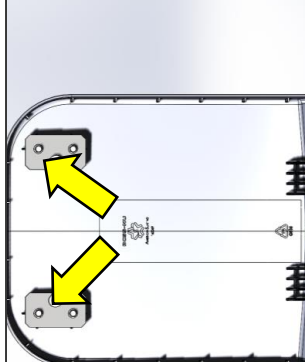
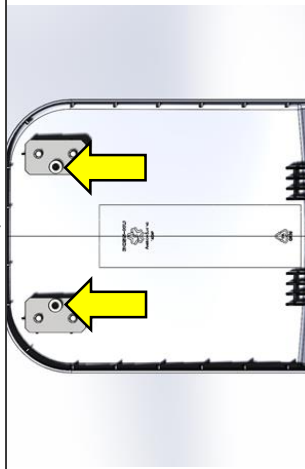

USE A 3/8" SOCKET

USE A 3/8" SOCKET TORQUE TO 40 IN-LBS



CHECK



DOUBLE CHECK



CYCLE TEST



TORQUE CHECK



GAUGE CHECK



SAFETY ALERT



FOCUS ARROW

Revision 9/4/14

FM 09.92



CHANGE BACK PLATE ON BC55

FMI – BC55 0008

PROCESS DESCRIPTION CHANGE BACK PLATE	REVISION A	ISSUE DATE 12/16/2020	M.E./AUTHOR DAWN ESTALIS	APPROVER TOM WARD
---	----------------------	---------------------------------	------------------------------------	-----------------------------

STEP 7 ASSEMBLE TWO NEW RUBBER GROMMETS (153117000) AND TWO NEW NYLON WASHERS (031339030)	STEP 8 HAND START 2 BOLTS (005730402401) TO ATTACH NEW PLATE (153291002)	STEP 9 TIGHTEN BOLTS
---	--	--------------------------------

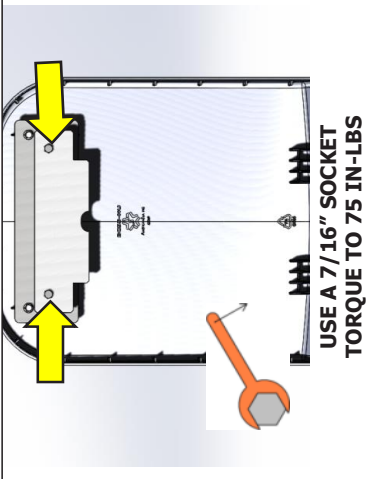
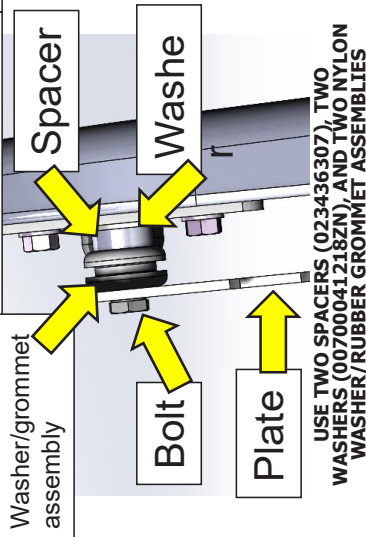
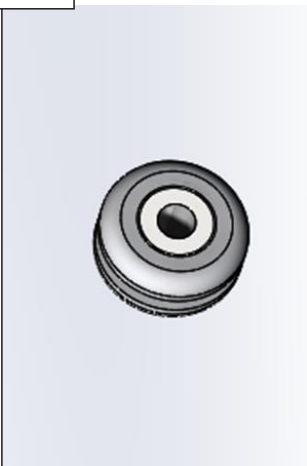

STEP 10 INSTALL BACK ON BC55 SEAT

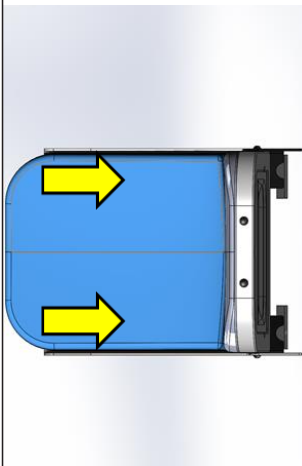

CHECK
 DOUBLE CHECK
 CYCLE TEST
 TORQUE CHECK
 GAUGE CHECK
 SAFETY ALERT
 FOCUS ARROW

FM 09.92

Revision 9/4/14