

**\* \* TECHNICAL INFORMATION NOTICE \* \***

DATE: July 22, 2021  
TO: Mitsubishi Motors US Service and Parts Managers  
RE: Axle Shaft Thread damage due to improper disassembly  
TIN NO.: TIN-21-26-001

.....

**AFFECTED VEHICLES:** 2022 Outlander and other models.

**PURPOSE:**

When removing the nut on the front CV Joint Axle be sure to "unstake" the nut prior to unthreading it from the axle shaft. Failure to do so will result in damage to the axle shaft threads. A narrow chisel or similar tool can be used to release the stacked area of the wheel hub lock nut.

**Note:** Warranty claims for axles with damage of this type are subject to verification.

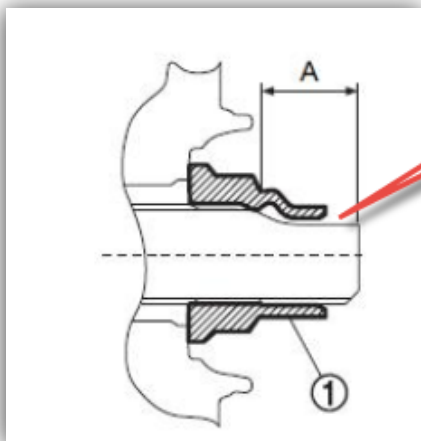
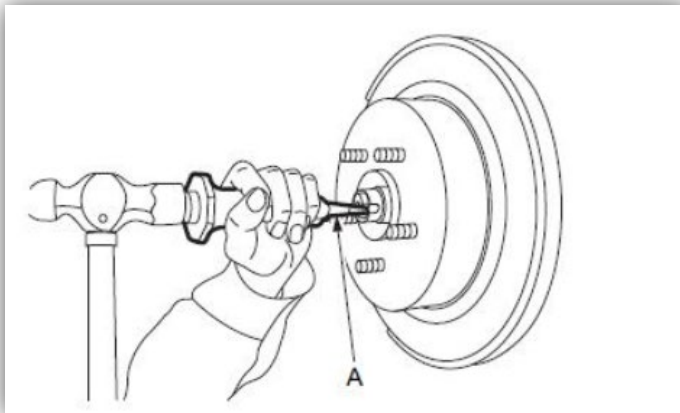

Insert Chisel here and pry staked portion nut up and away from axle threads.

