



SIB 61 01 21 CUSTOMIZED ENCODING FOR AUTHORITY VEHICLES

2021-05-05

This Service Information Bulletin replaces SI 61 01 21 **dated February 2021**.

MODEL

E-Series	Model Description
K52	R 1250 RT
K80	F 750 GS
K81	F 850 GS

SITUATION

Special vehicles, Police, for example, should be configured/encoded with ISTA.
(e.g. installation of radio transceiver, activation of switch outputs for electrical accessories).

Individualization for special vehicles is multifaceted and very complex.

CORRECTION

The attached guides contain directions for correctly adjusting the encoding in current authority vehicles.

PROCEDURE

(Information only: The encoding of the special vehicle is saved in the vehicle order).
Starting with ISTA version 4.23.1x, some encoding titles were adjusted to make the processes as clear as possible.

QUESTIONS REGARDING THIS BULLETIN

Technical inquiries	Contact the BMW Technical Support Group via TSARA
Warranty inquiries	Submit an IDS ticket to the Warranty Department
Parts inquiries	Submit an IDS ticket to the Motorrad Parts Department

Supporting Materials

[picture_as_pdf Individualisation Authority Bike F750GS F850GS ENG.pdf](#)

[picture_as_pdf 61 01 21 Customized encoding for Authority Vehicles.pdf](#)

[picture_as_pdf Individualisation Authority Bike R1250RT ENG.pdf](#)

[picture_as_pdf Power circuit of authority vehicle.pdf](#)

[picture_as_pdf Power circuit of authority vehicle K52MÜ.pdf](#)

Service Information Bulletin

General Electrical Systems

May 5, 2021

61 01 21

CUSTOMIZED ENCODING FOR AUTHORITY VEHICLES



This Service Information Bulletin replaces SI 61 01 21 **dated February 2021**.

MODEL

E-Series	Model Description
K52	R 1250 RT
K80	F 750 GS
K81	F 850 GS

SITUATION

Special vehicles, Police, for example, should be configured/encoded with ISTA.
(e.g. installation of radio transceiver, activation of switch outputs for electrical accessories).

Individualization for special vehicles is multifaceted and very complex.

CORRECTION

The attached guides contain directions for correctly adjusting the encoding in current authority vehicles.

PROCEDURE

(Information only: The encoding of the special vehicle is saved in the vehicle order).
Starting with ISTA version 4.23.1x, some encoding titles were adjusted to make the processes as clear as possible.

QUESTIONS REGARDING THIS BULLETIN

Technical inquiries	Contact the BMW Technical Support Group via TSARA
Warranty inquiries	Submit an IDS ticket to the Warranty Department
Parts inquiries	Submit an IDS ticket to the Motorrad Parts Department

INDIVIDUALISATION AUTHORITY BIKE

GUIDELINE FOR CODING IN ISTA (F750/F850GS AUTHORITY BIKE)



EX-VC-21 May 2020

INTRODUCTION „INDIVIDUALISATION AUTHORITY BIKE“

In this guideline are shown some individualizations for the F750/F850GS authority bike in simplified form

Basically:

- All representation are only recommendations and are not mandatory coding
- HO-words with similar functions interfere with each other
 - > HO-Words are codings that can be imported via ISTA
- This manual describes the coding options without the SA877 (radio preparation)
 - >Circular 6/2016 (German market only) must be observed for vehicles with the SA877
 - >The HO-Words F1P1,F1P2 und F1DP (for example function key 1) are controlled over LIN-Bus and can only operated with the SA877
- This manual describes the coding options without the SA113 (US authority), because all outputs of the GMSF are already pre-assigned

DIRECTORY

<u>HO-words:</u>	<u>ISTA description:</u>	<u>page:</u>
➤ F1PT	12 V supply plug connection radio	4
➤ F1VF,F2VF,F3VF o. F4VF	Supply voltage to radio (X865 Pin2)	5
➤ F1SA,F2SA,F3SA o. F4SA	Activation of pin 46 (GMSF)	6
➤ F123,F223,F323 o. F423	Switching output of rear STOP signal indicator (X1214*2B Pin 3)	7
➤ F135,F235,F335 o. F435	Switching output of front STOP signal indicator (X1464*1B u. 2B Pin 2)	8
➤ F136,F236,F335 o. F436	Switching output of rear STOP signal indicator (X1214 *1B u. 2B Pin 2)	9
➤ F147,F247,F347 o. F447	Switching output of rear fog light (E165 Pin2)	10
➤ KLSV	Customer load at rear STOP signal indicator output (GMSF Pin 23)	11
➤ KLBF	Customer load at front STOP signal indicator output (GMSF Pin 35)	12
➤ KLSH	Customer load at rear STOP signal indicator output (GMSF Pin 36)	13
➤ KLNS	Customer load on output of rear fog light (GMSF Pin 47)	14
➤ SB10,SB15,SB20	Activation of alternating headlights with authority lights switched on	15
➤ AFAN,AFAS	Storage options for the alternating front light operating mode	15
➤ XK46	12 V output on pin 46 (GMSF) active, when front flashing beacons are activated	16

POWER SUPPLY FOR RADIO WITH IGNITION ON (WITHOUT SA877)

F1PT: 12 V on Pin 5 GMSF (A362) to (plug X865*1B Pin 2)

12 Volt power supply for radio with ignition "ON" (max. 10 Ampere; 90 minutes after-run time)

Ground on plug X865*1B Pin

- Correct connector plug (X865*1B):
- 6113 8367075 Pin housing (4-pin)
- 6113 1376193 Pin contact (1,5-2,5mm²)
- 6113 9344421 Pin contact (2,5-4,0mm²)

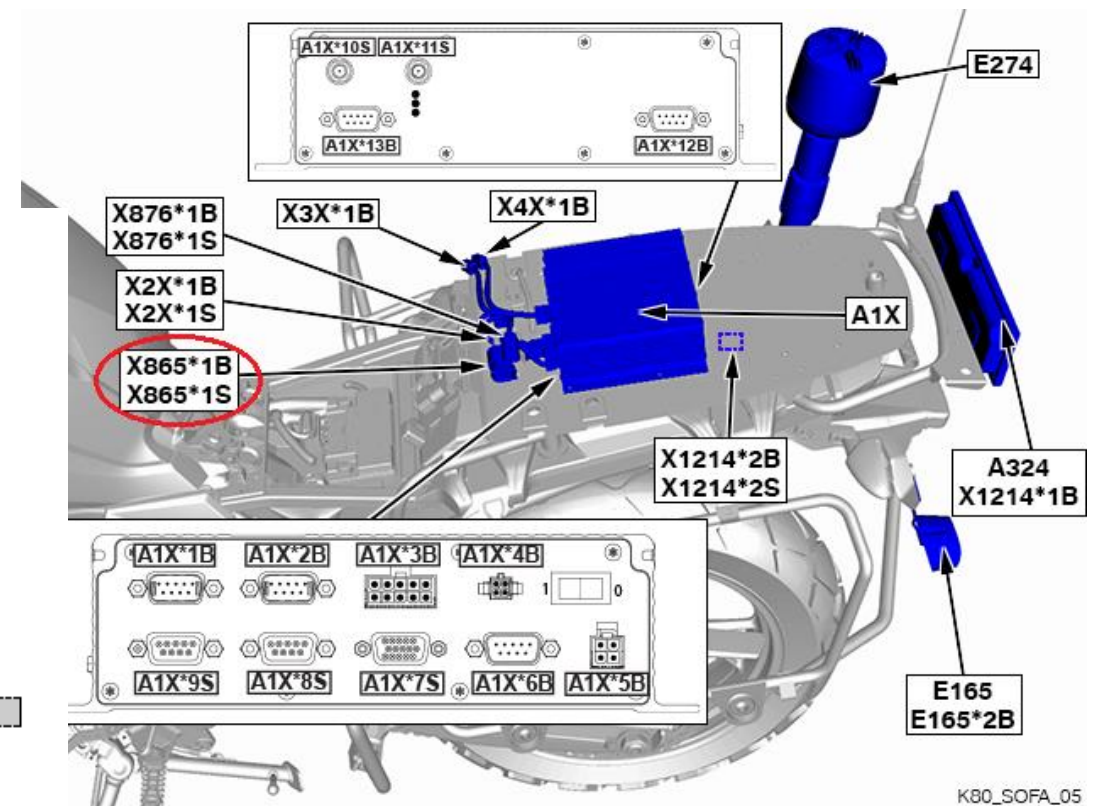
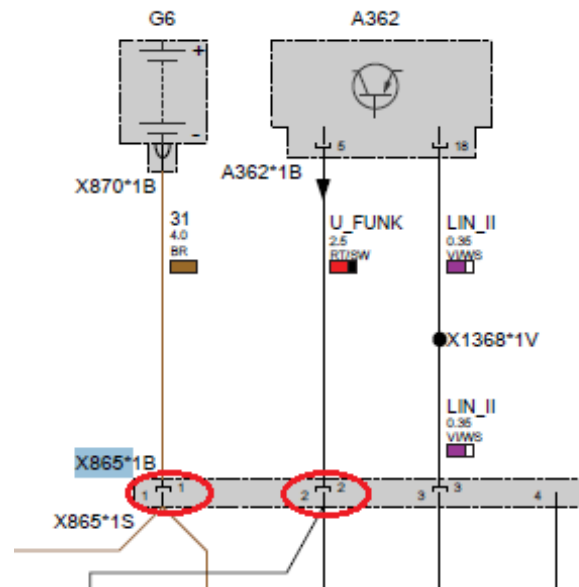

K80_SOFA_05

SWITCHING OUTPUT FOR RADIO ABOUT THE FUNCTION KEY (WITHOUT SA877)

F1VF; F2VF; F3VF o. F4VF: 12 V on Pin 5 GMSF (A362) to (plug X865*1B Pin 2) with function key
 12 Volt power supply for radio with pressing function key (max. 10 Ampere; 90 minutes after-run time)
 Ground on plug X865*1B Pin 1

For this function is also additional HO-word required (for example function key 1):

F1SA: Power supply to plug X865*1B

F1TR: Latching function

or

F1TT: Keying function

- Correct connector plug (X865*1B):
- 6113 8367075 Pin housing (4-pin)
- 6113 1376193 Pin contact (1,5-2,5mm²)
- 6113 9344421 Pin contact (2,5-4,0mm²)

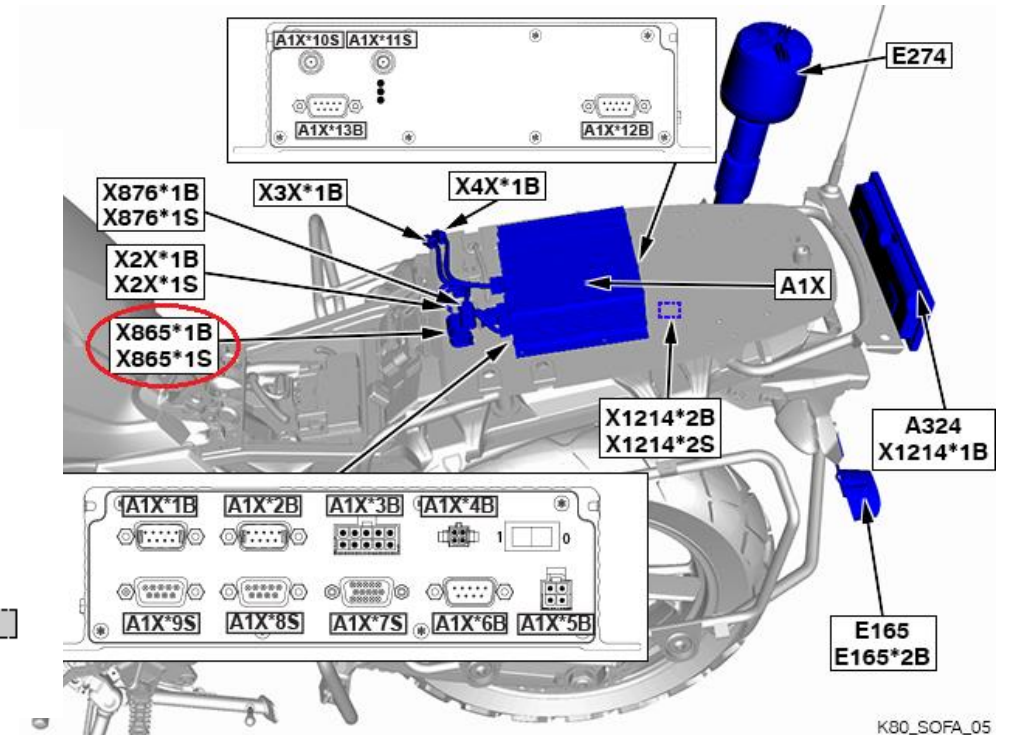
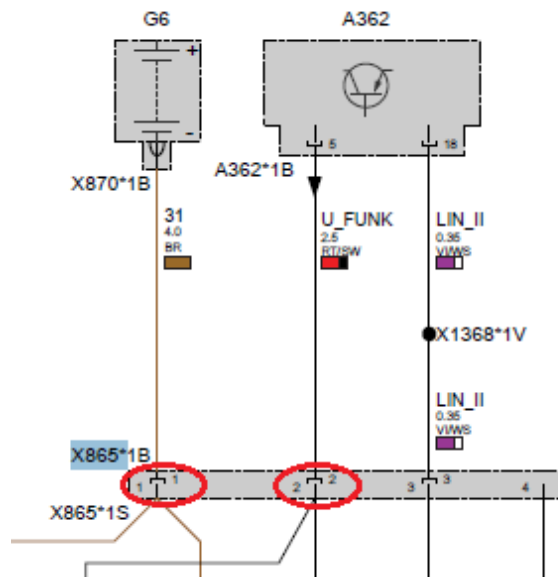

K80_SOFA_05

SWITCHING OUTPUT FOR ELECTRICAL ACCESSORIES ON SA-PLUG ON FUNCTION KEY

F1SA; F2SA; F3SA o. F4SA: 12 V on Pin 46 GMSF (A362) to (plug X886*1B Pin 3)

12 Volt power supply on SA-plug with pressing function key (max. 6 Ampere; 90 minutes after-run time)

Ground on plug X886*1B Pin 1

For this function is also additional HO-word required (for example function key 1):

F1TR: Latching function

or

F1TT: Keying function

- Correct connector plug (X886*1B):
- 6113 8364625 Pin housing (6-pin)
- 6113 8366269 Pin contact (0,5-0,75mm²)
- 6113 8366245 Single wire sealing
- 6113 8366249 Sealing grommet

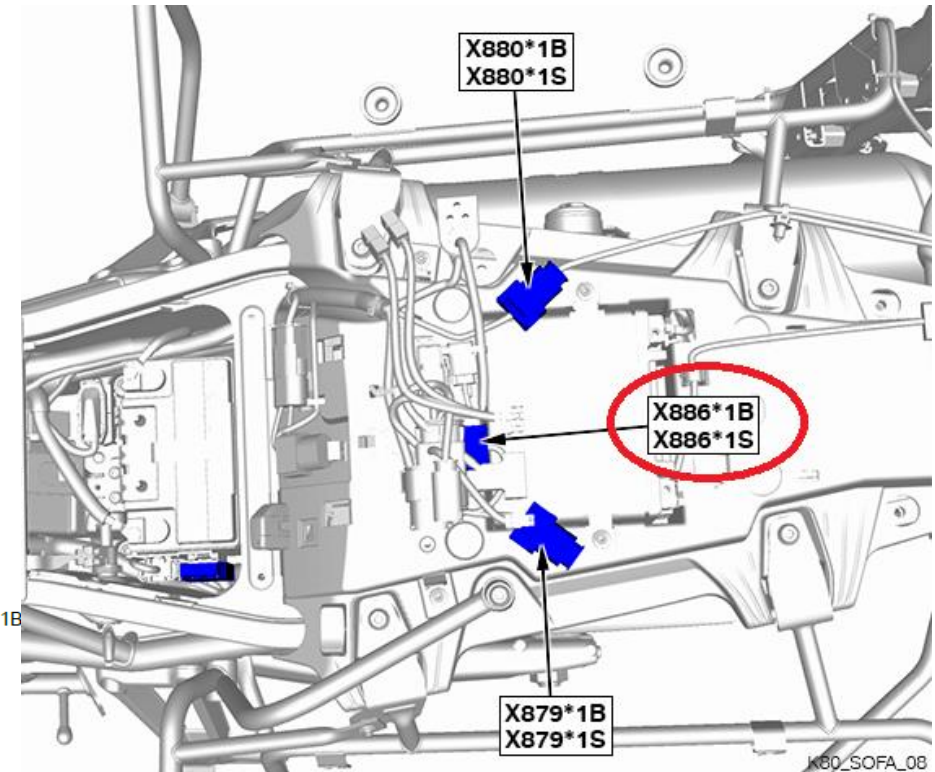
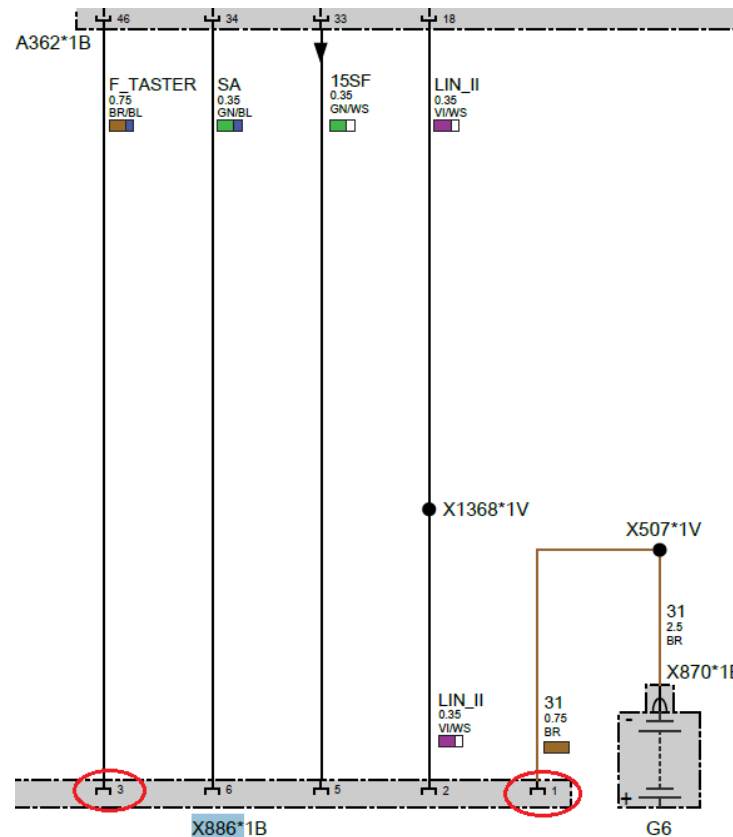

SWITCHING OUTPUT OF REAR STOP SIGNAL ON FUNCTION KEY (GMSF PIN 23)

Requirement: No rear stop signal may be installed; the SA521 must not be included in the vehicle order

F123; F223; F323 o. F423: 12 V on Pin 23 GMSF (A362) to plug (X1214*2B Pin 3) with function key

12 Volt power supply on plug rear stop signal with pressing function key (max. 0,65 Ampere; 30 minutes after-run time)

Ground on plug X1214*2B Pin 1

(Softwarebug: no 12 Volt power supply, currently Failure solved with I-level K001-20-11-501)

For this function is also additional HO-word required (for example function key 1):

F1SA: Power supply to plug X1214*2B

F1TR: Latching function

or

F1TT: Keying function

- Correct connector plug (X1214*2B):

- 6113 8365393 Pin housing (3-pin)
- 6113 1393703 Pin contact (0,2-0,5mm²)
- 6113 8366247 Single wire sealing
- 6113 8366249 Sealing grommet

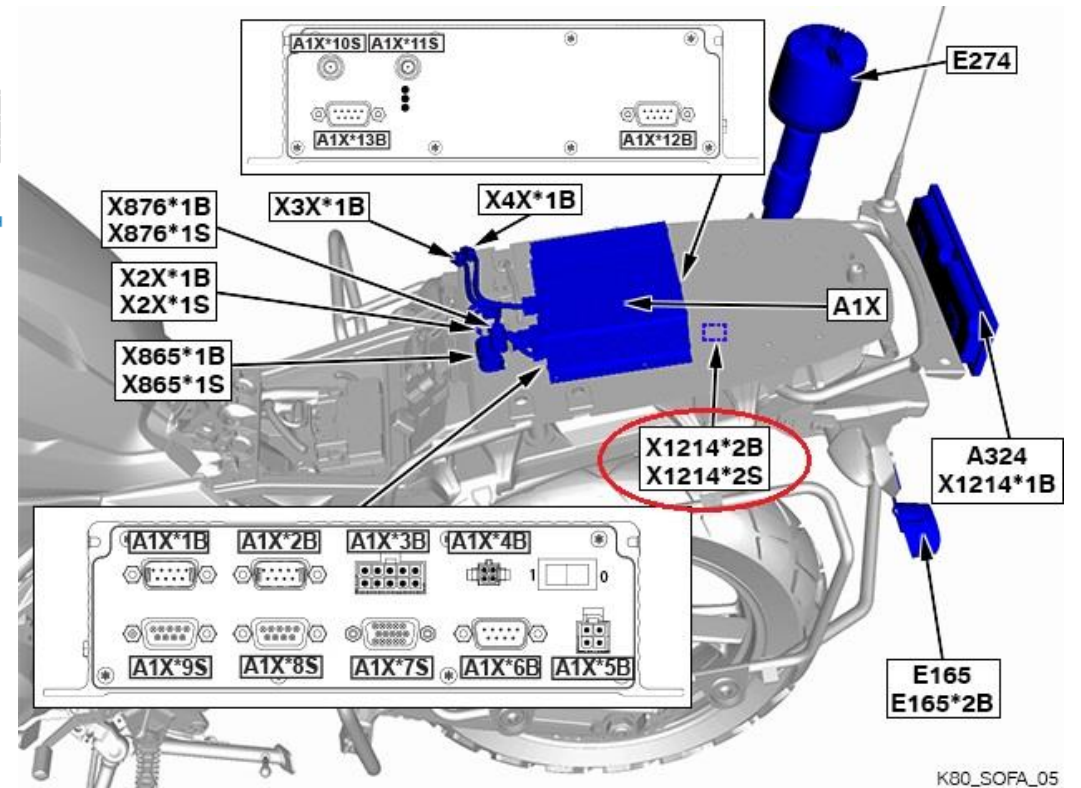
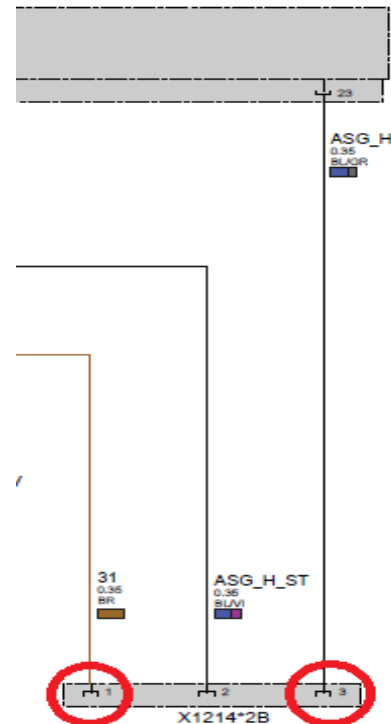

K80_SOFA_05

SWITCHING OUTPUT OF FRONT STOP SIGNAL ON FUNCTION KEY (GMSF PIN 35)

Requirement: No front stop signal may be installed; the SA242 must not be included in the vehicle order (plug behind the instrument cluster)

F135; F235; F335 o. F435: 12 V on Pin 35 GMSF (A362) to plug (X1464*1B and 2B Pin 2) with function key

12 Volt power supply on plug front stop signal with pressing function key (max. 2 Ampere; 30 minutes after-run time)

Ground on plug X1464*1B and 2B Pin 1

For this function is also additional HO-word required (for example function key 1):

F1SA: Power supply to plug X1464*2B

F1TR: Latching function

or

F1TT: Keying function

- Correct connector plug (X1464*2B):
- 6113 8365393 Pin housing (3-pin)
- 6113 1393703 Pin contact (0,2-0,5mm²)
- 6113 8366247 Single wire sealing
- 6113 8366249 Sealing grommet

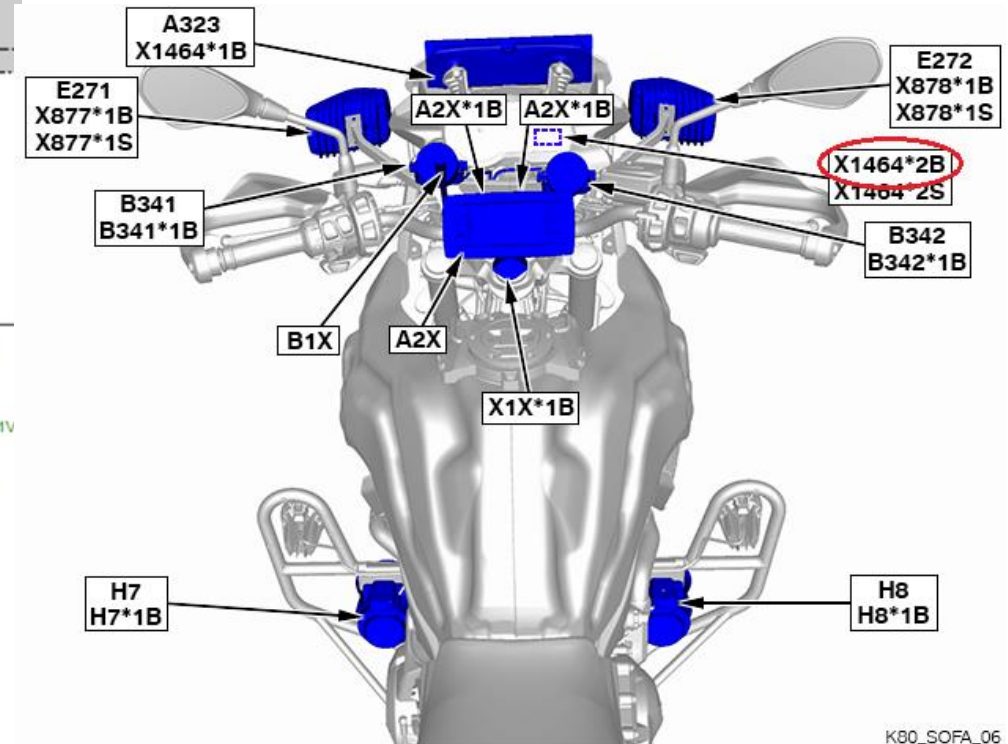
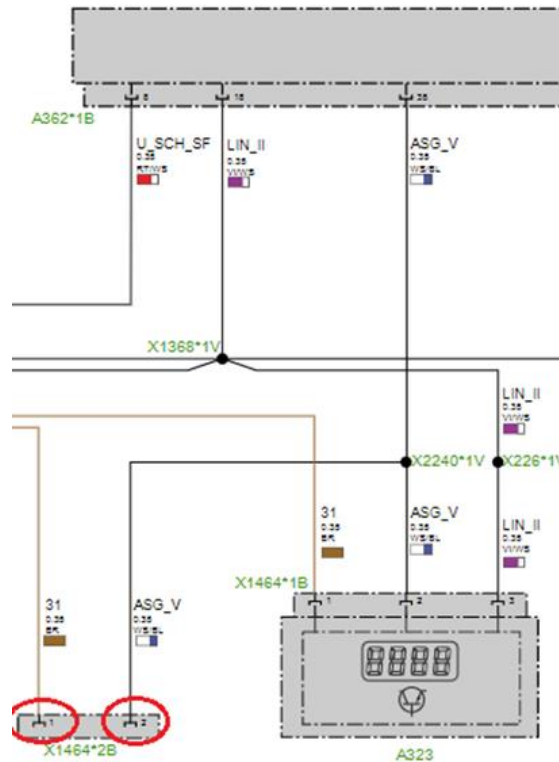

K80_SOFA_06

SWITCHING OUTPUT OF REAR STOP SIGNAL ON FUNCTION KEY (GMSF PIN 36)

Requirement: No rear stop signal may be installed; the SA521 must not be included in the vehicle order

F136; F236; F336 o. F436: 12 V on Pin 36 GMSF (A362) to plug (X1214*1B u. 2B Pin 2) with function key

12 Volt power supply on plug rear stop signal with pressing function key (max. 2 Ampere; 30 minutes after-run time)

Ground on plug X1214*B Pin 1

For this function is also additional HO-word required (for example function key 1):

F1SA: Power supply to plug X1214*2B

F1TR: Latching function

or

F1TT: Keying function

- Correct connector plug (X1214*2B):
- 6113 8365393 Pin housing (3-pin)
- 6113 1393703 Pin contact (0,2-0,5mm²)
- 6113 8366247 Single wire sealing
- 6113 8366249 Sealing grommet

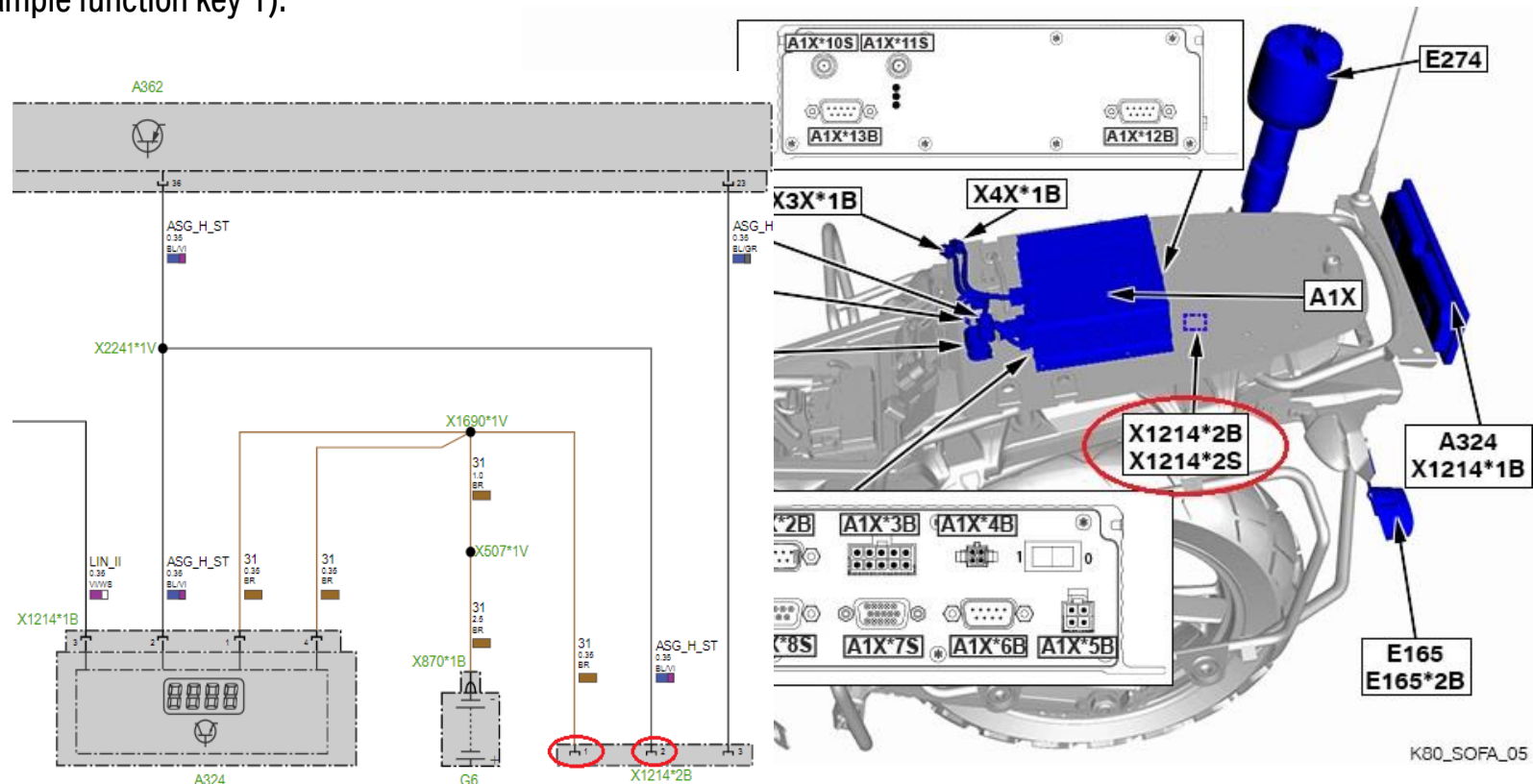

SWITCHING OUTPUT OF REAR FOG LIGHT ON FUNCTION KEY (GMSF PIN 47)

Requirement: No rear fog light may be installed; the SA573 must not be included in the vehicle order

F147; F247; F347 o. F447: 12 V on Pin 47 GMSF (A362) to plug (E165*1B Pin2) with function key

12 Volt power supply on rear fog light with pressing function key (max. 2 Ampere; no after-run time)

Ground on plug E165*1B Pin 1

For this function is also additional HO-word required (for example function key 1):

F1SA: Power supply to plug E165*1B

F1TR: Latching function

or

F1TT: Keying function

- Correct connector plug (E165*1B):
- 8330 0402344 Repair plug (2-pin)
- or
- 6113 8366275 Pin housing (2-pin)
- 6113 8366269 Pin contact (0,5-0,75mm²)
- 6113 8366245 Single wire sealing
- 6113 8366249 Sealing grommet

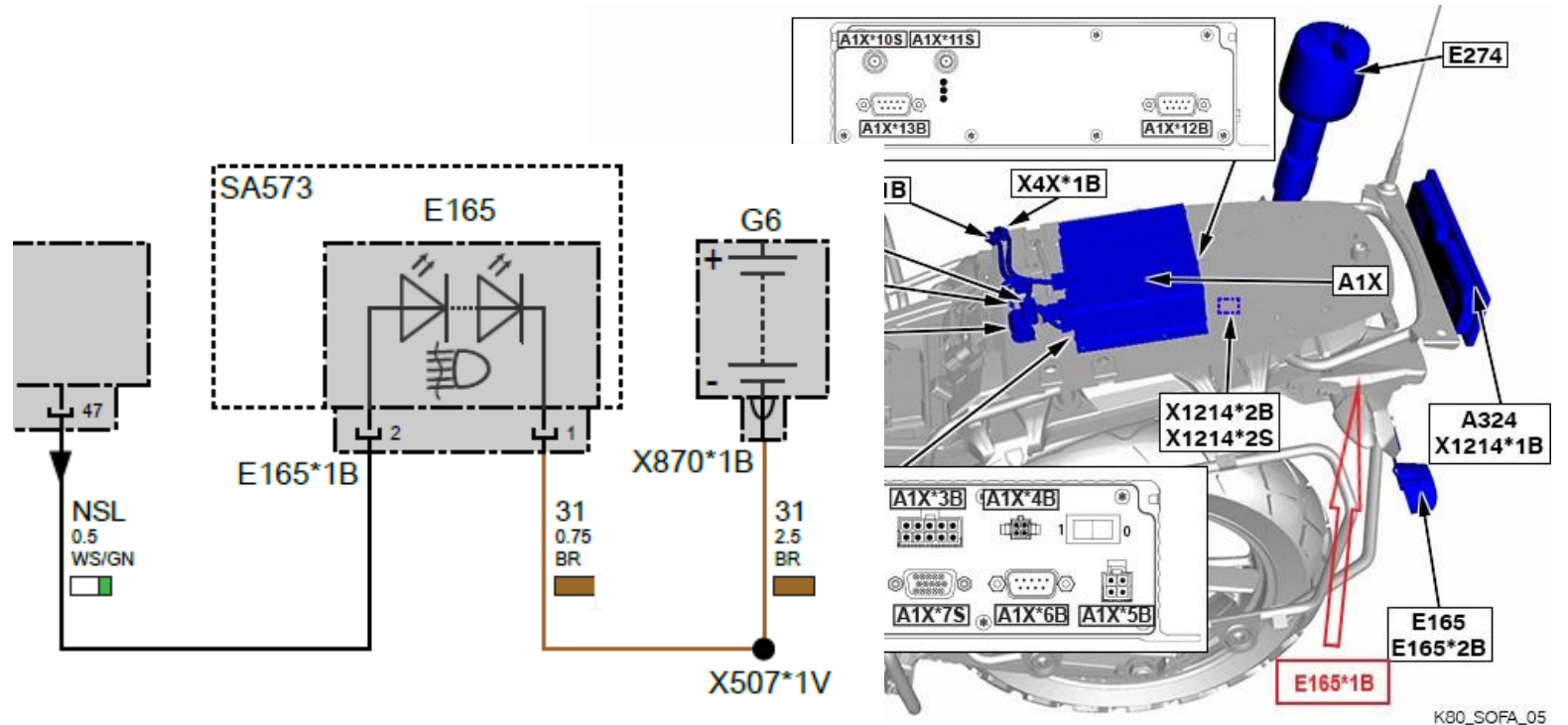

CUSTOMER LOAD ON OUTPUT OF REAR STOP SIGNAL (GMSF PIN 23)

Requirement: No rear stop signal may be installed; the SA521 must not be included in the vehicle order

KLSV: 12 V on Pin 23 GMSF (A362) to plug (X1214*2B Pin 3)

12 Volt power supply on plug rear stop signal with pressing button „A“(max. 0,65 Ampere; 30 minutes after-run time)

Ground on plug X1214*2B Pin 1

(Softwarebug: no 12 Volt power supply, Failure solved with I-level K001-20-11-501)

- Correct connector plug (X1214*2B):
- 6113 8365393 Pin housing (3-pin)
- 6113 1393703 Pin contact (0,2-0,5mm²)
- 6113 8366247 Single wire sealing
- 6113 8366249 Sealing grommet

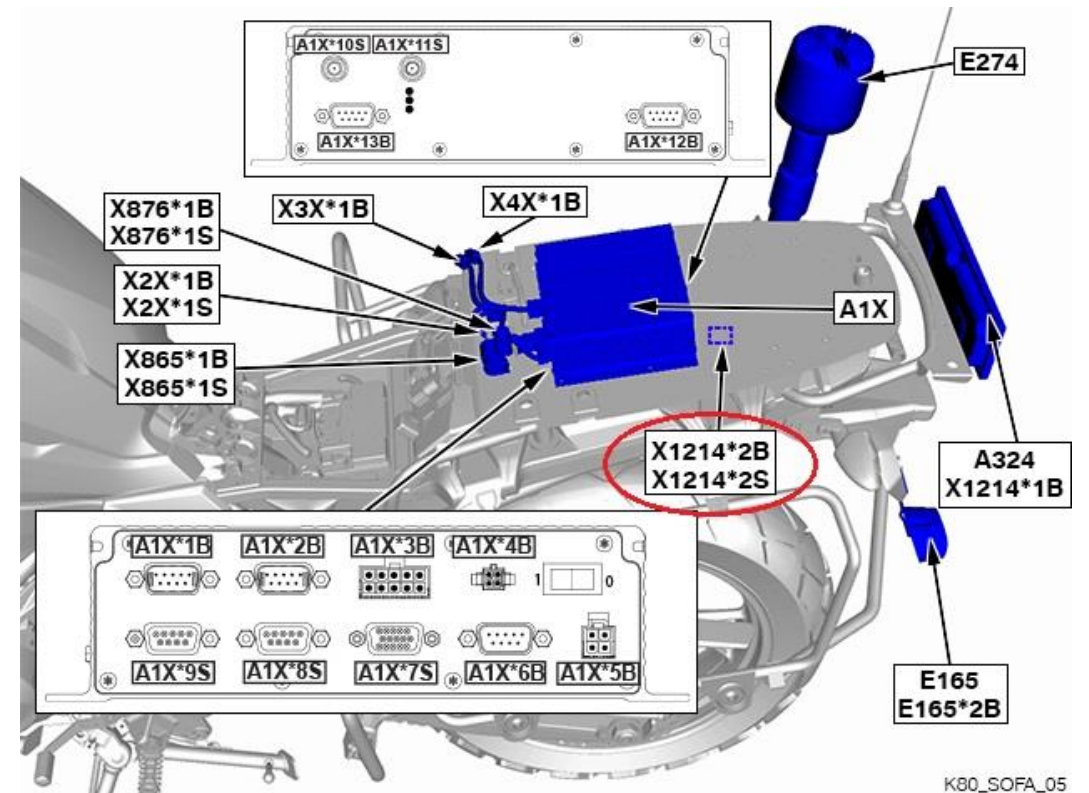

K80_SOFA_05

CUSTOMER LOAD ON OUTPUT OF FRONT STOP SIGNAL (GMSF PIN 35)

Requirement: No front stop signal may be installed; the SA242 must not be included in the vehicle order

KLBF: 12 V on Pin 35 GMSF (A362) to plug (X1464*1B und 2B; Pin 2)

12 Volt power supply on plug front stop signal with pressing button „N“(max. 2 Ampere; 30 minutes after-run time)

Ground on plug X1464*1B u 2B Pin 1

(Softwarebug: lag time only 4 minutes, Failure solved with I-level K001-20-07-500)

- Correct connector plug (X1464*2B):

- 6113 8365393 Pin housing (3-pin)
- 6113 1393703 Pin contact (0,2-0,5mm²)
- 6113 8366247 Single wire sealing
- 6113 8366249 Sealing grommet

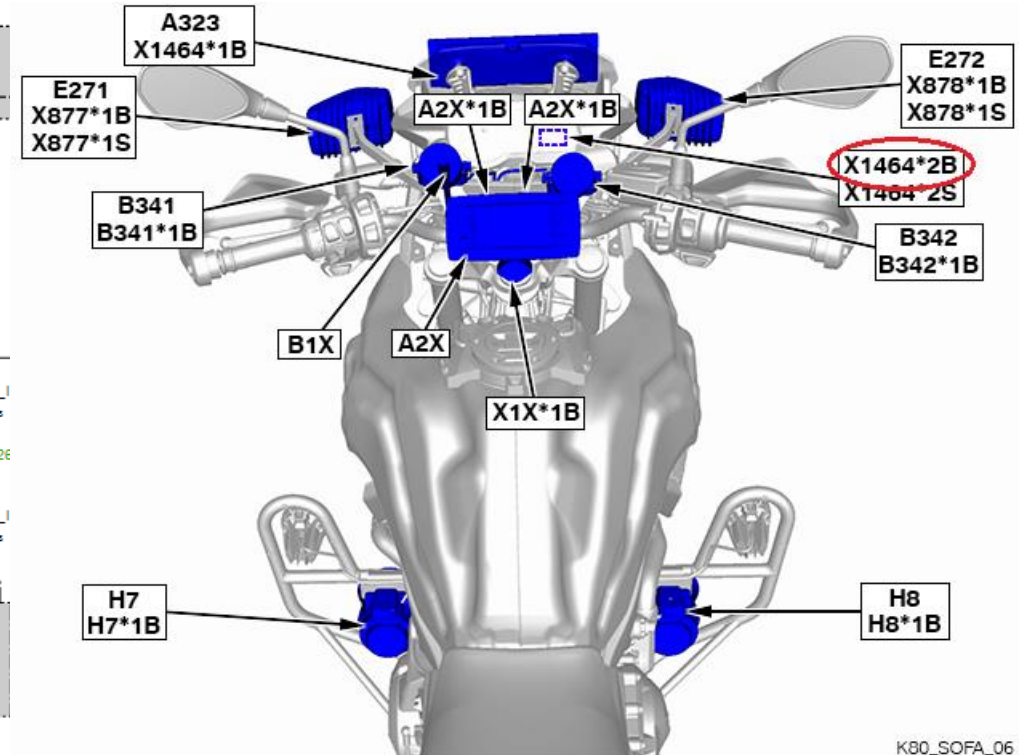
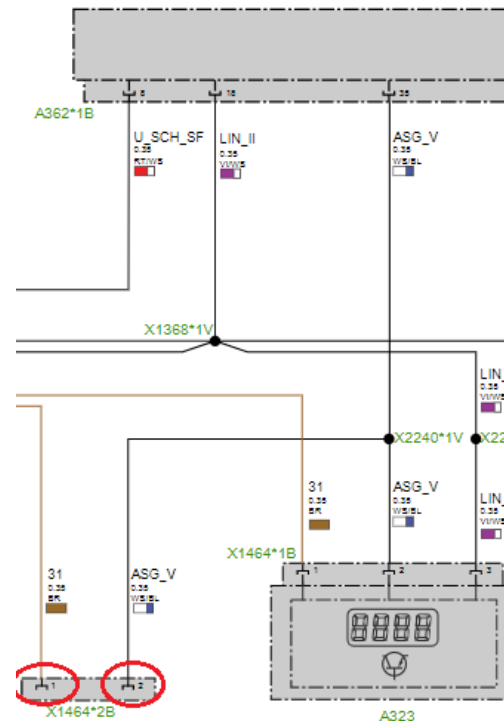

K80_SOFA_06

FLASHING WARNING LIGHTS HEADLIGHT (ALTERNATING HEADLIGHT)

The "Alternating headlight" can be set in 3 different frequencies (low beam and high beam are controlled alternately):

SB10: Flashing warning lights headlight 1 Hz

SB15: Flashing warning lights headlight 1,5 Hz

SB20: Flashing warning lights headlight 2 Hz

With active front flashing lights is the alternating headlight activated, when there is enough light (light sensor in the I-kombi)

(Softwarebug with TFT; Failure solved with I-level K001-21-03-500)

Furthermore, the alternating front light can be switched off with a long press on the "J" key

For this function is following Ho-word necessary:

AFAN: Do not save alternating frontal light state

or

AFAS: Save alternating frontal light state

(Softwarebug with US variant: can not be switched off with button „J“; Failure solved with I-level K001-21-07-500)



POWER SUPPLY FOR ELECTRICAL ACCESSORIES ON SA-PLUG WITH FRONT FLASHING LIGHTS

With active front flashing lights, a 12 volt power supply is also supplied to the SA plug

XK46: 12 V on Pin 46 GMSF (A362) to plug (X886*1B Pin 3)

Ground on plug X886*1B Pin 1

- Correct connector plug (X886*1B):

- 6113 8364625 Pin housing (6-pin)
- 6113 8366269 Pin contact (0,5-0,75mm²)
- 6113 8366245 Single wire sealing
- 6113 8366249 Sealing grommet

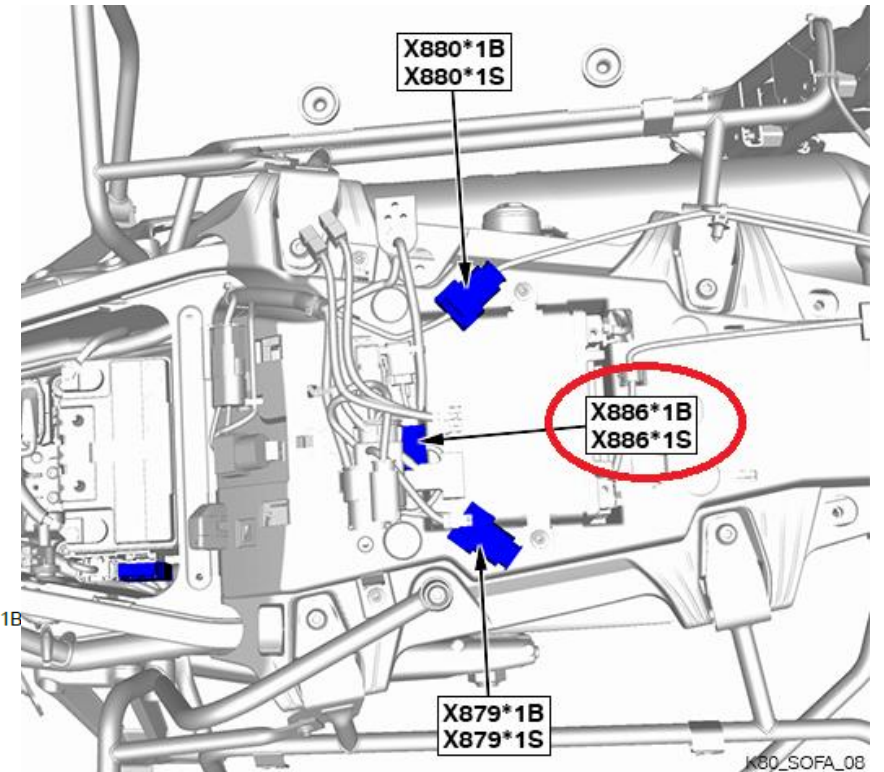
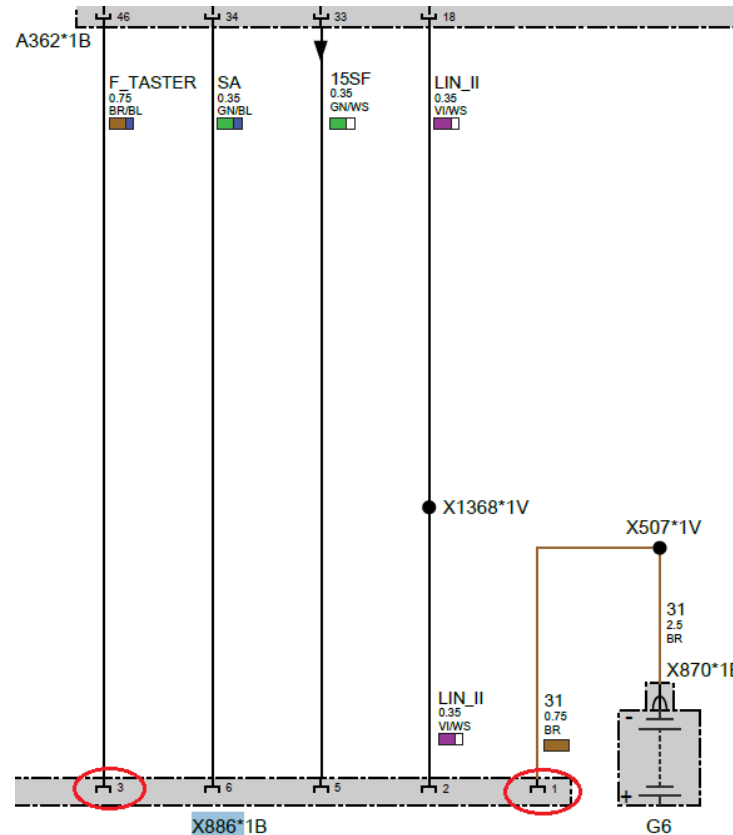

INDIVIDUALISATION AUTHORITY BIKE

GUIDELINE FOR CODING IN ISTA (R1250RT AUTHORITY BIKE)



EX-VC-21 May 2020

INTRODUCTION „INDIVIDUALISATION AUTHORITY BIKE“

In this guideline are shown some individualizations for the R1250RT authority bike in simplified form

Basically:

- All representation are only recommendations and are not mandatory coding
- HO-Words with similar functions interfere with each other
 - > HO-Words are codings that can be imported via ISTA
- This manual describes the coding options without the SA877 (radio preparation)
 - >Circular 6/2016 (German market only) must be observed for vehicles with the SA877
 - >The HO-Words F1P1,F1P2 und F1DP (for example function key 1) are controlled over LIN-Bus and can only operated with the SA877
- This manual describes the coding options without the SA113 (US authority), because all outputs of the GMSF are already pre-assigned

Hint:

The predecessor R1200RT authority bike (K52 SF) has slight deviations (see circuit diagram)

The Pinning from stop signal (front and rear) was changed

The GMSF Pin output 23 and 35 was exchanged

DIRECTORY

<u>HO-Words:</u>	<u>ISTA description:</u>	<u>Page:</u>
➤ F1PT	12 V supply plug connection radio	4
➤ F1VF,F2VF,F3VF o. F4VF	Supply voltage to radio (X865 Pin2)	5
➤ F1SA,F2SA,F3SA o. F4SA	Activation of pin 46 (GMSF)	6
➤ F123,F223,F323 o. F423	Switching output of rear STOP signal indicator (X1214*2B Pin 3)	7
➤ F135,F235,F335 o. F435	Switching output of front STOP signal indicator (X1464*1B u. 2B Pin 2)	8
➤ F136,F236,F335 o. F436	Switching output of rear STOP signal indicator (X1214 *1B u. 2B Pin 2)	9
➤ F147,F247,F347 o. F447	Switching output of rear fog light (E165 Pin2)	10
➤ KLSV	Customer load at rear STOP signal indicator output (GMSF Pin 23)	11
➤ KLBF	Customer load at front STOP signal indicator output (GMSF Pin 35)	12
➤ KLSH	Customer load at rear STOP signal indicator output (GMSF Pin 36)	13
➤ KLNS	Customer load on output of rear fog light (GMSF Pin 47)	14
➤ SB10,SB15,SB20	Activation of alternating headlights with authority lights switched on	15
➤ AFAN,AFAS	Storage options for the alternating front light operating mode	15
➤ XK46	12 V output on pin 46 (GMSF) active, when front flashing beacons are activated	16

POWER SUPPLY FOR RADIO WITH IGNITION ON (WITHOUT SA877)

F1PT: 12 V on Pin 5 GMSF (A362) to (plug X865*1B Pin 2)

12 Volt power supply for radio with ignition "ON" (max. 10 Ampere; 90 minutes after-run time)

Ground on plug X865*1B Pin1

- Correct connector plug (X865*1B):
- 6113 8367075 Pin housing (4-pin)
- 6113 1376193 Pin contact (1,5-2,5mm²)
- 6113 9344421 Pin contact (2,5-4,0mm²)

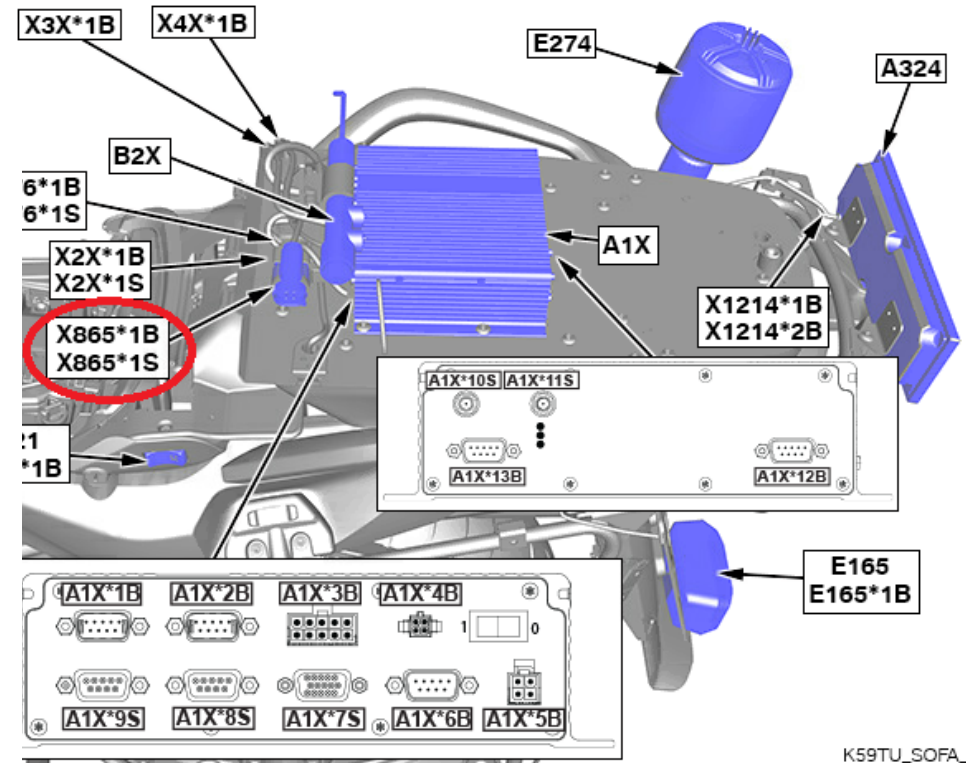
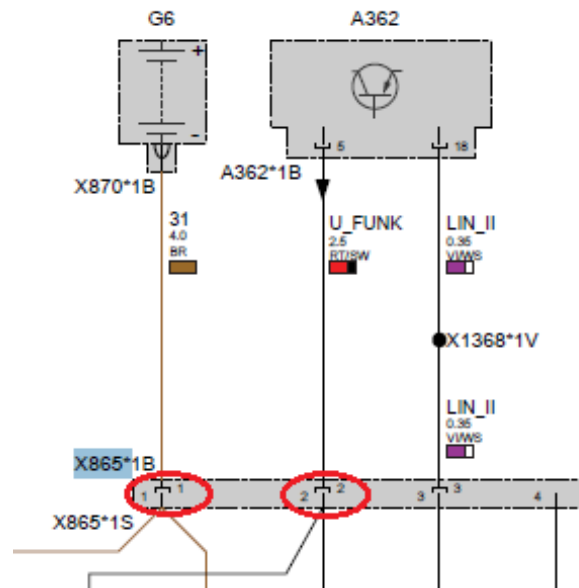

K59TU_SOFA_02

SWITCHING OUTPUT FOR RADIO ABOUT THE FUNCTION KEY (WITHOUT SA877)

F1VF; F2VF; F3VF o. F4VF: 12 V on Pin 5 GMSF (A362) to (plug X865*1B Pin 2) with function key
 12 Volt power supply for radio with pressing function key (max. 10 Ampere; 90 minutes after-run time)

Ground on plug X865*1B Pin 1

For this function is also additional HO-Word required (for example function key 1):

F1SA: Power supply to plug X865*1B

F1TR: Latching function

or

F1TT: Keying function

- Correct connector plug (X865*1B):
- 6113 8367075 Pin housing (4-pin)
- 6113 1376193 Pin contact (1,5-2,5mm²)
- 6113 9344421 Pin contact (2,5-4,0mm²)

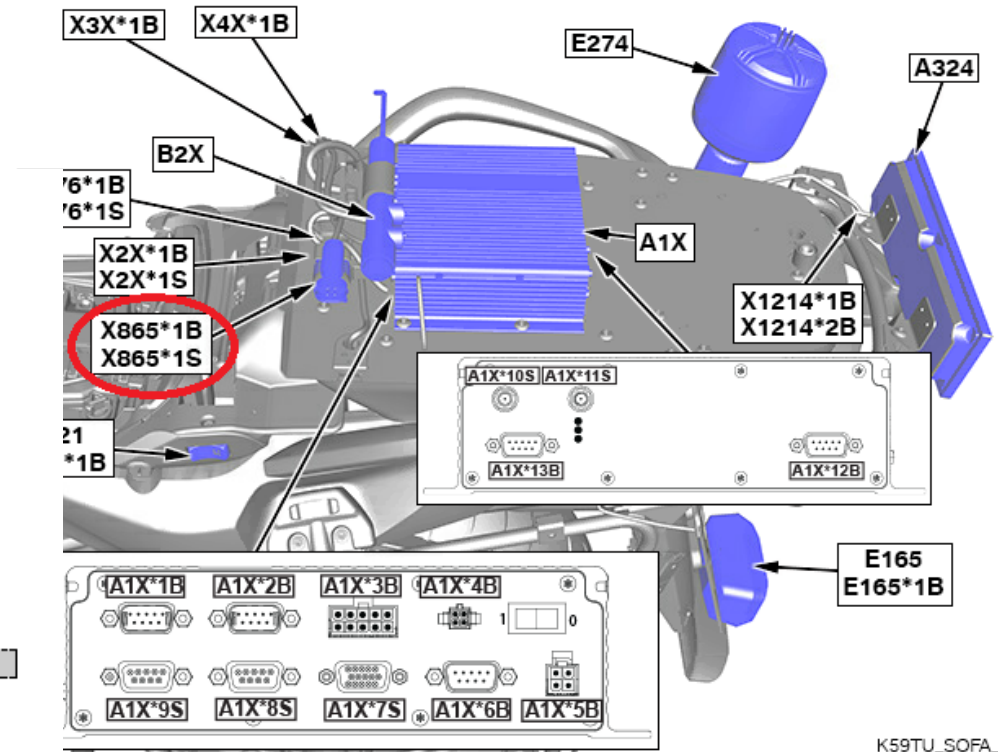
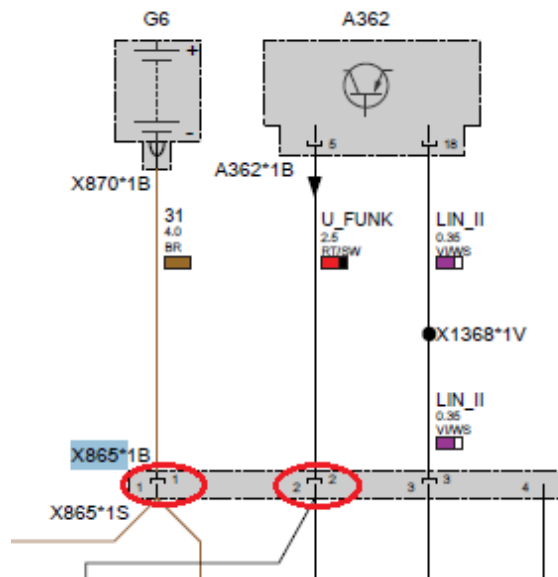

K59TU_SOFA_02

SWITCHING OUTPUT FOR ELECTRICAL ACCESSORIES ON SA-PLUG ON FUNCTION KEY

F1SA; F2SA; F3SA o. F4SA: 12 V on Pin 46 GMSF (A362) to (plug X886*1B Pin 3)

12 Volt power supply on SA-plug with pressing function key (max. 6 Ampere; 90 minutes after-run time)

Ground on plug X886*1B Pin 1

For this function is also additional HO-Word required (for example function key 1):

F1TR: Latching function

or

F1TT: Keying function

- Correct connector plug (X886*1B):
- 6113 8364625 Pin housing (6-pin)
- 6113 8366269 Pin contact (0,5-0,75mm²)
- 6113 8366245 Single wire sealing
- 6113 8366249 Sealing grommet

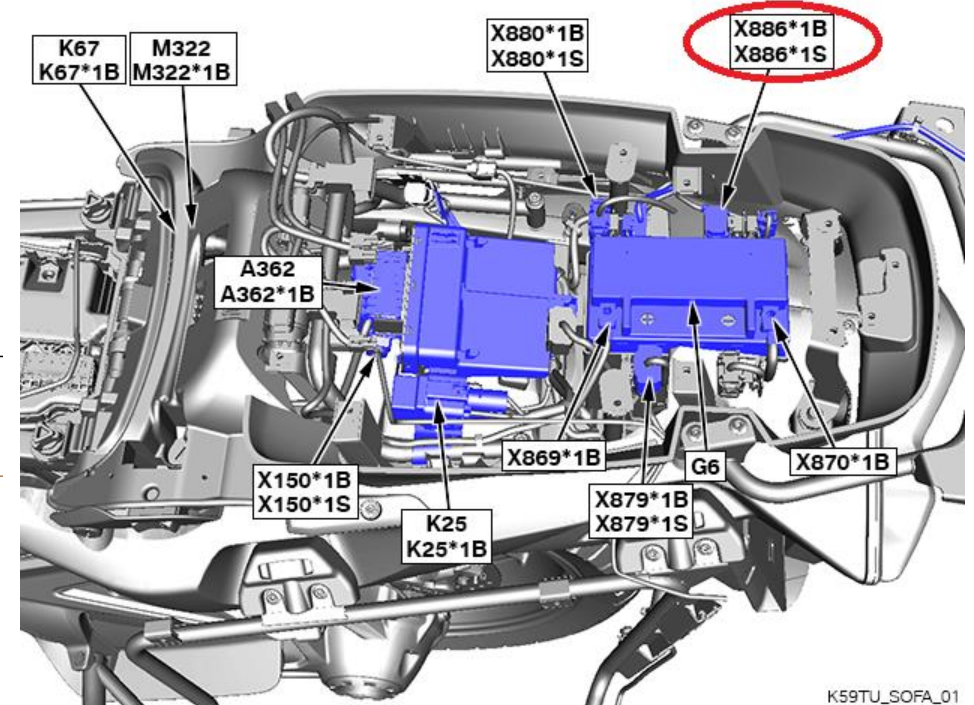
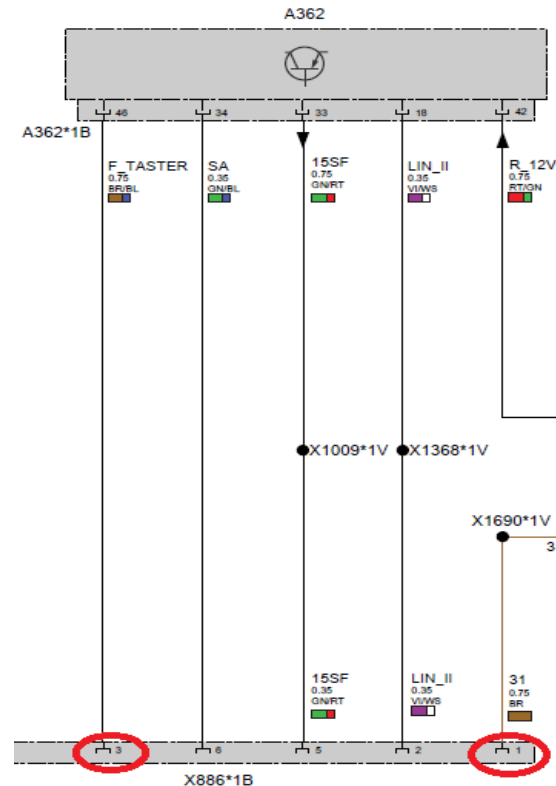

K59TU_SOFA_01

SWITCHING OUTPUT OF REAR STOP SIGNAL ON FUNCTION KEY (GMSF PIN 23)

Requirement: No rear stop signal may be installed; the SA521 must not be included in the vehicle order

F123; F223; F323 o. F423: 12 V on Pin 23 GMSF (A362) to plug (X1214*2B Pin 3) with function key

12 Volt power supply on plug rear stop signal with pressing function key (max. 0,65 Ampere; 30 minutes after-run time)

Ground on plug X1214*2B Pin 1

(Softwarebug: no 12 Volt power supply, Failure solved with I-level K001-20-11-501)

For this function is also additional HO-Word required (for example function key 1):

F1SA: Power supply to plug X1214

F1TR: Latching function

or

F1TT: Keying function

- Correct connector plug (X1214*2B):

- 6113 8365393 Pin housing (3-pin)
- 6113 1393703 Pin contact (0,2-0,5mm²)
- 6113 8366247 Single wire sealing
- 6113 8366249 Sealing grommet
-

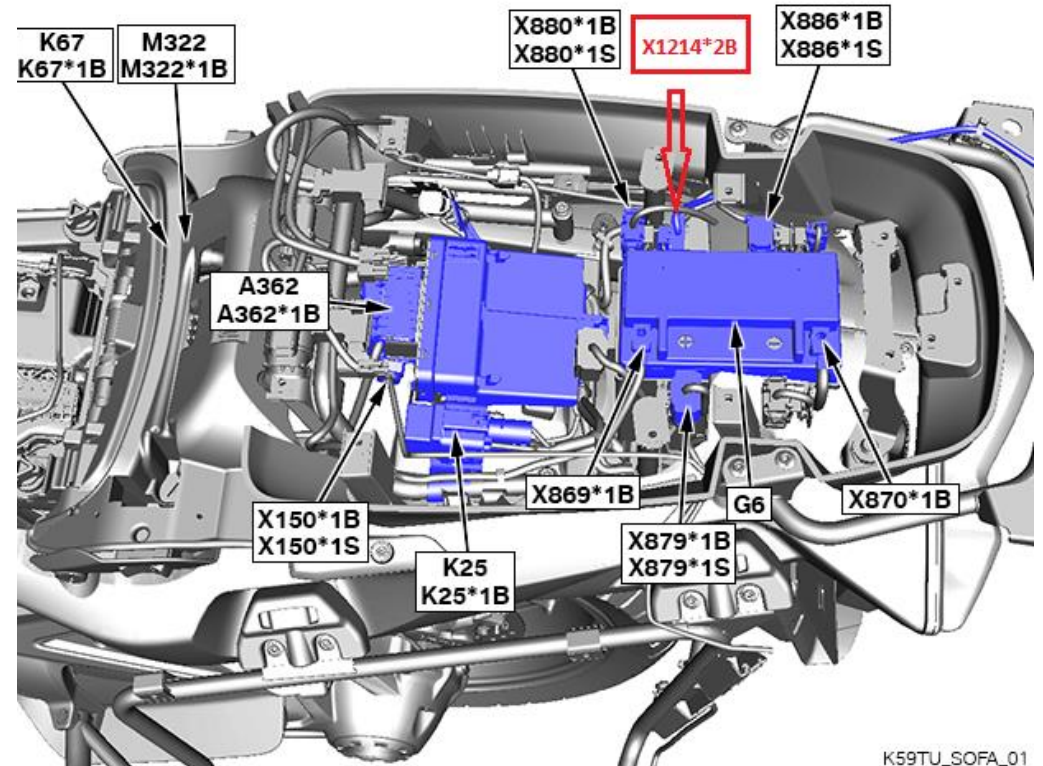
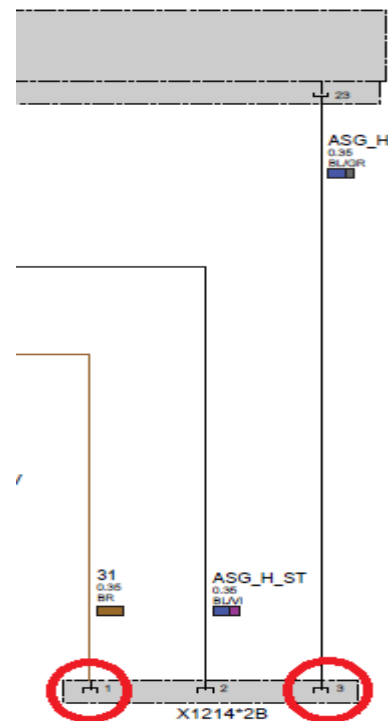

K59TU_SOFA_01

SWITCHING OUTPUT OF FRONT STOP SIGNAL ON FUNCTION KEY (GMSF PIN 35)

Requirement: No front stop signal may be installed; the SA242 must not be included in the vehicle order (plug behind the instrument cluster)

F135; F235; F335 o. F435: 12 V on Pin 35 GMSF (A362) to plug (X1464*1B and 2B Pin 2) with function key

12 Volt power supply on plug front stop signal with pressing function key (max. 2 Ampere; 30 minutes after-run time)

Ground on plug X1464*1B and 2B Pin 1

For this function is also additional HO-Word required (for example function key 1):

F1SA: Power supply to plug X1464*2B

F1TR: Latching function

or

F1TT: Keying function

- Correct connector plug (X1464*2B):
- 6113 8365393 Pin housing (3-pin)
- 6113 1393703 Pin contact (0,2-0,5mm²)
- 6113 8366247 Single wire sealing
- 6113 8366249 Sealing grommet

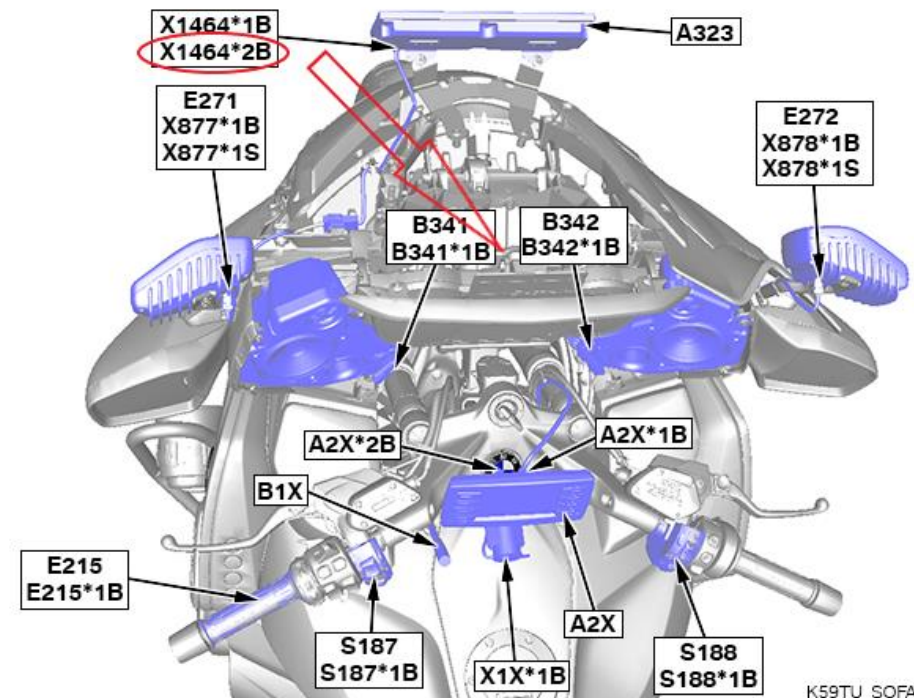
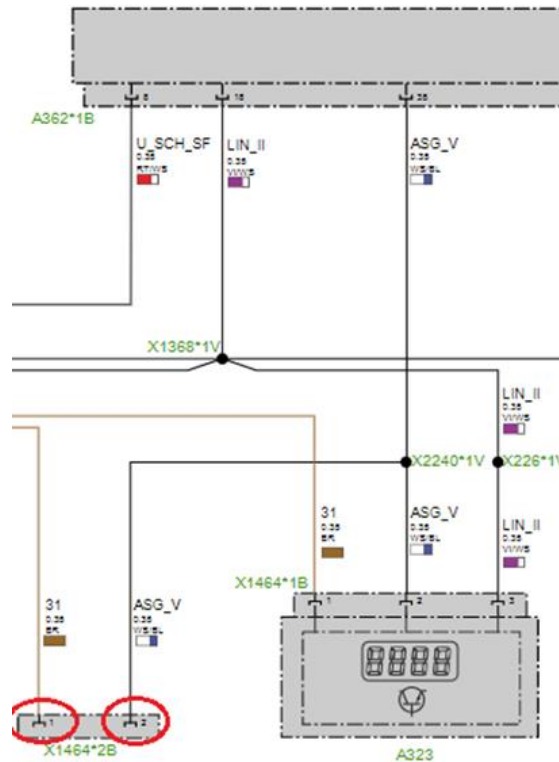

K59TU_SOFA_03

SWITCHING OUTPUT OF REAR STOP SIGNAL ON FUNCTION KEY (GMSF PIN 36)

Requirement: No rear stop signal may be installed; the SA521 must not be included in the vehicle order

F136; F236; F336 o. F436: 12 V on Pin 36 GMSF (A362) to plug (X1214*1B u. 2B Pin 2) with function key

12 Volt power supply on plug rear stop signal with pressing function key (max. 2 Ampere; 30 minutes after-run time)

Ground on plug X1214*B Pin 1

For this function is also additional HO-Word required (for example function key 1):

F1SA: Power supply to plug X1214*2B

F1TR: Latching function

or

F1TT: Keying function

- Correct connector plug (X1214*2B):
- 6113 8365393 Pin housing (3-pin)
- 6113 1393703 Pin contact (0,2-0,5mm²)
- 6113 8366247 Single wire sealing
- 6113 8366249 Sealing grommet

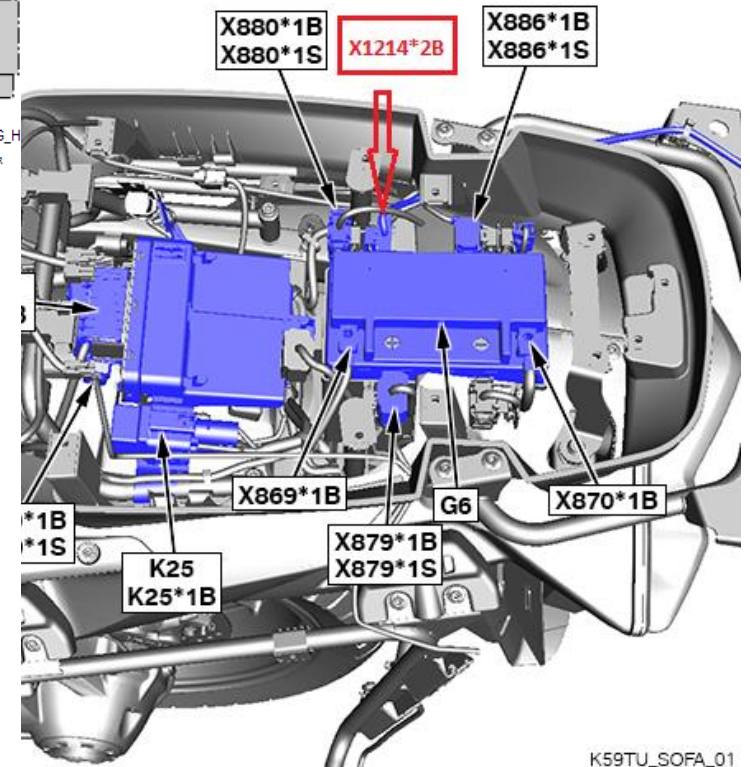
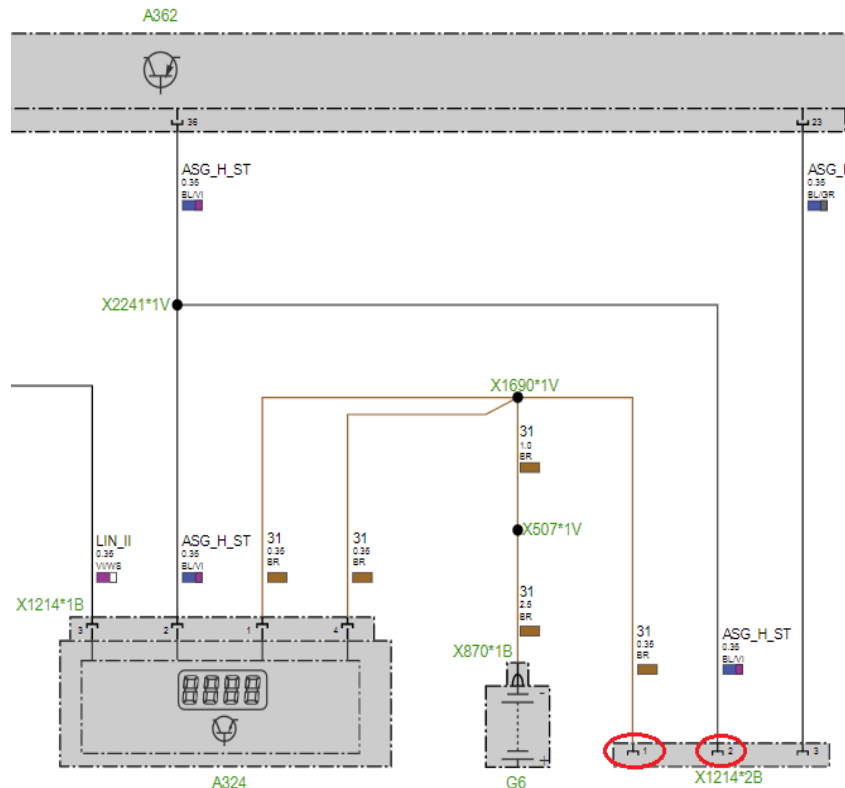

K59TU_SOFA_01

SWITCHING OUTPUT OF REAR FOG LIGHT ON FUNCTION KEY (GMSF PIN 47)

Requirement: No rear fog light may be installed; the SA573 must not be included in the vehicle order

F147; F247; F347 o. F447: 12 V on Pin 47 GMSF (A362) to plug (E165*1B Pin2) with function key

12 Volt power supply on rear fog light with pressing function key (max. 2 Ampere; no after-run time)

Ground on plug E165*1B Pin 1

For this function is also additional HO-Word required (for example function key 1):

F1SA: Power supply to plug E165*1B

F1TR: Latching function

or

F1TT: Keying function

- Correct connector plug (E165*1B):
- 8330 0402344 Repair plug (2-pin)
- or
- 6113 8366275 Pin housing (2-pin)
- 6113 8366269 Pin contact (0,5-0,75mm²)
- 6113 8366245 Single wire sealing
- 6113 8366249 Sealing grommet

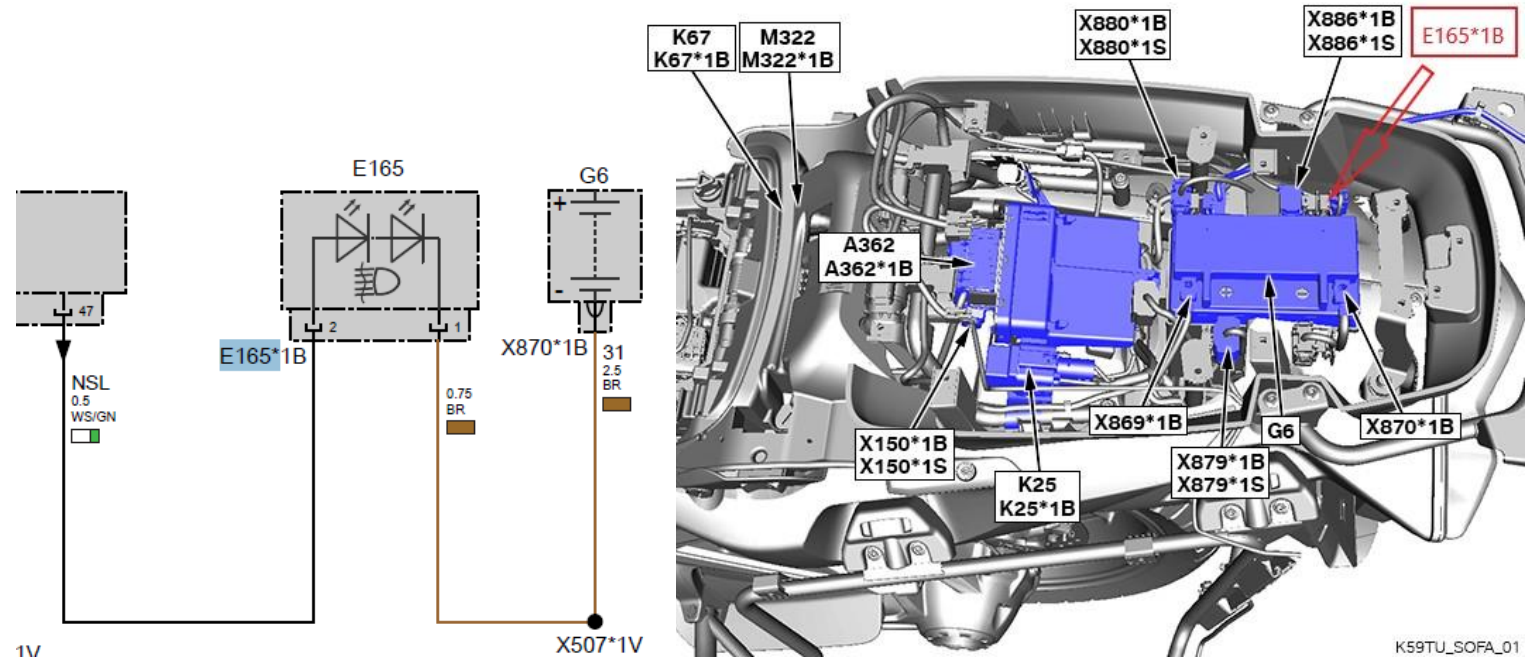

CUSTOMER LOAD ON OUTPUT OF REAR STOP SIGNAL (GMSF PIN 23)

Requirement: No rear stop signal may be installed; the SA521 must not be included in the vehicle order

KLSV: 12 V on Pin 23 GMSF (A362) to plug (X1214*2B Pin 3)

12 Volt power supply on plug rear stop signal with pressing button „A“(max. 0,65 Ampere; 30 minutes after-run time)

Ground on plug X1214*2B Pin 1

(Softwarebug: no 12 Volt power supply, Failure solved with I-level K001-20-11-501)

- Correct connector plug (X1214*2B):

- 6113 8365393 Pin housing (3-pin)
- 6113 1393703 Pin contact (0,2-0,5mm²)
- 6113 8366247 Single wire sealing
- 6113 8366249 Sealing grommet

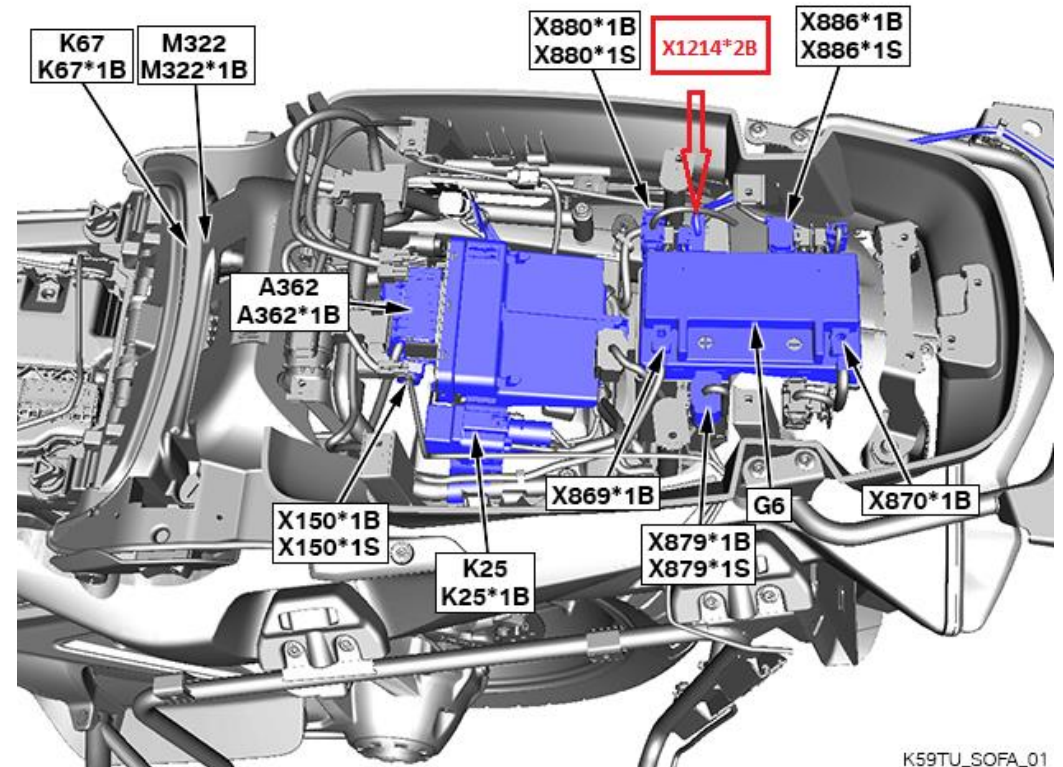
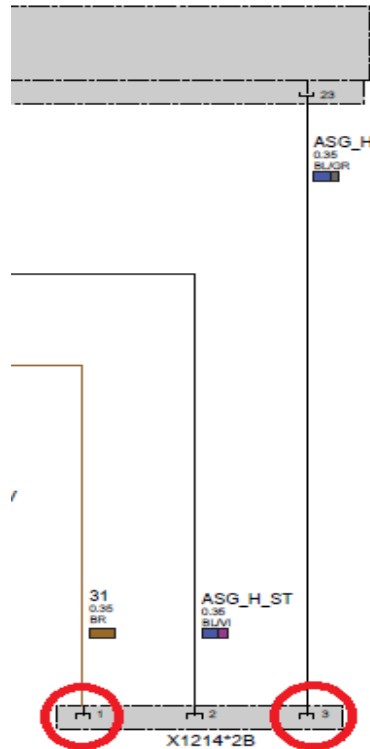

K59TU_SOFA_01

CUSTOMER LOAD ON OUTPUT OF FRONT STOP SIGNAL (GMSF PIN 35)

Requirement: No front stop signal may be installed; the SA242 must not be included in the vehicle order (plug behind the instrument cluster)

KLBF: 12 V on Pin 35 GMSF (A362) to plug (X1464*1B und 2B; Pin 2)

12 Volt power supply on plug front stop signal with pressing button „N“(max. 2 Ampere; 30 minutes after-run time)

Ground on plug X1464*1B u 2B Pin 1

(Softwarebug: lag time only 4 minutes, Failure solved with I-level K001-20-07-500)

- Correct connector plug (X1464*2B):
- 6113 8365393 Pin housing (3-pin)
- 6113 1393703 Pin contact (0,2-0,5mm²)
- 6113 8366247 Single wire sealing
- 6113 8366249 Sealing grommet

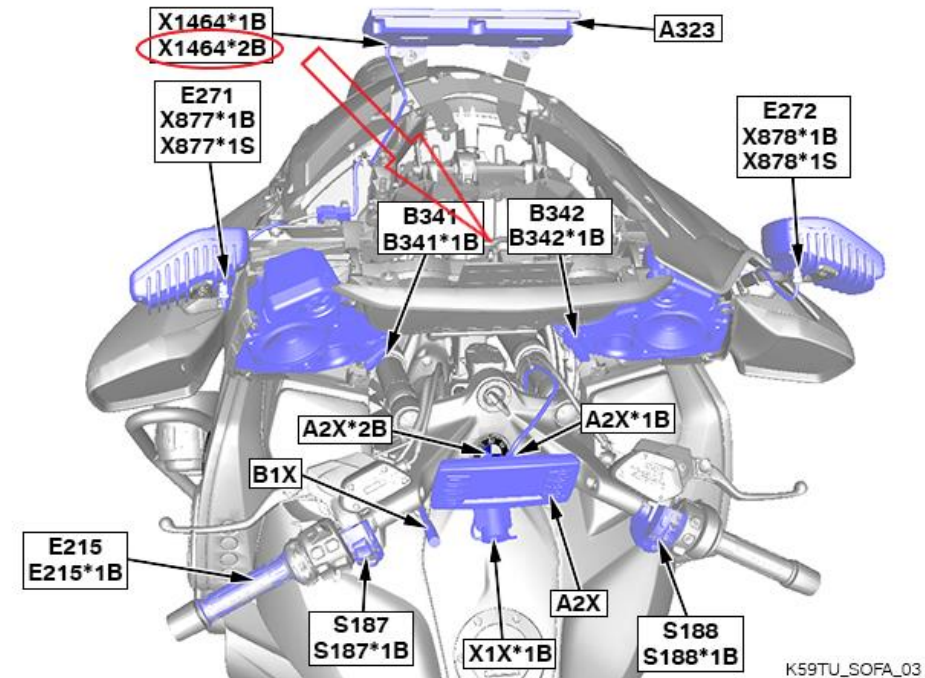
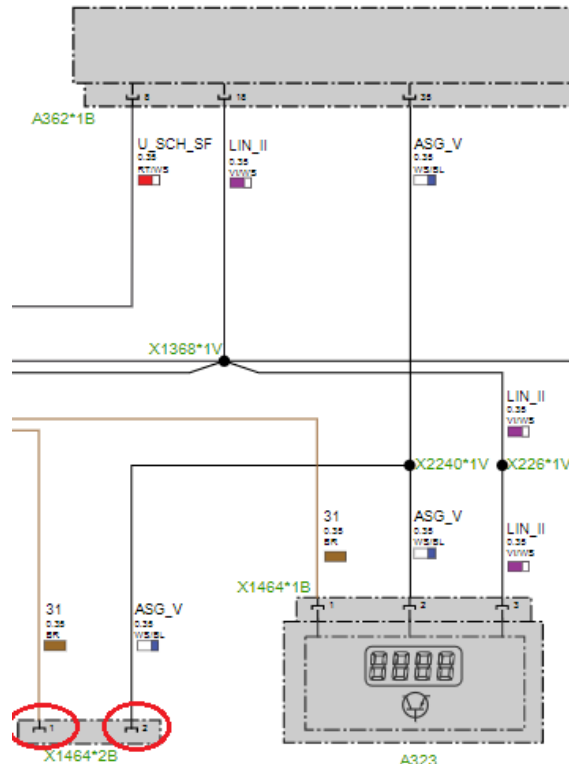

K59TU_SOFA_03

CUSTOMER LOAD ON OUTPUT OF REAR STOP SIGNAL (GMSF PIN 36)

Requirement: No rear stop signal may be installed; the SA521 must not be included in the vehicle order

KLSH: 12 V on Pin 36 GMSF (A362) to plug (X1214*1B und 2B ; Pin 2)

12 Volt power supply on plug rear stop signal with pressing button „M“ (max. 2 Ampere; 30 minutes after-run time)

Ground on plug X1214*2B Pin 1

(Softwarebug: lag time only 4 minutes, Failure solved with I-level K001-20-07-500)

- Correct connector plug (X1214*2B):

- 6113 8365393 Pin housing (3-pin)
- 6113 1393703 Pin contact (0,2-0,5mm²)
- 6113 8366247 Single wire sealing
- 6113 8366249 Sealing grommet

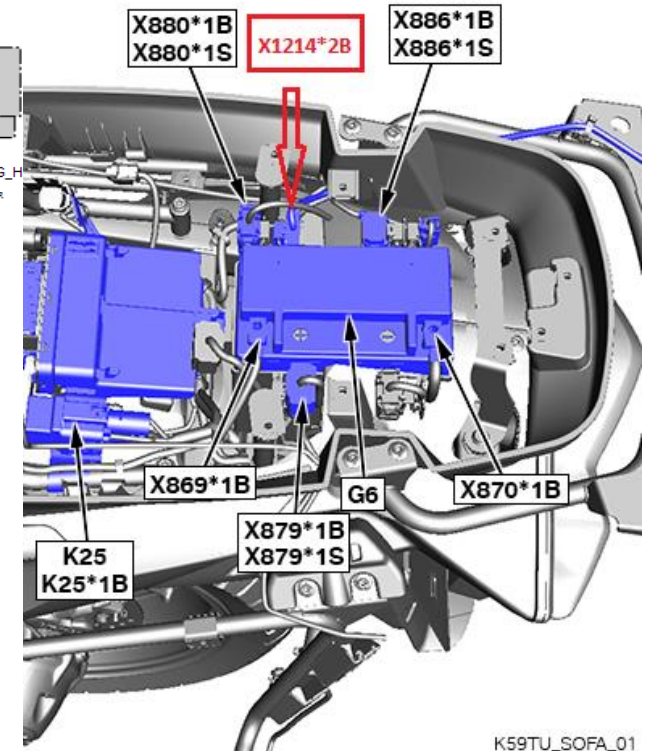
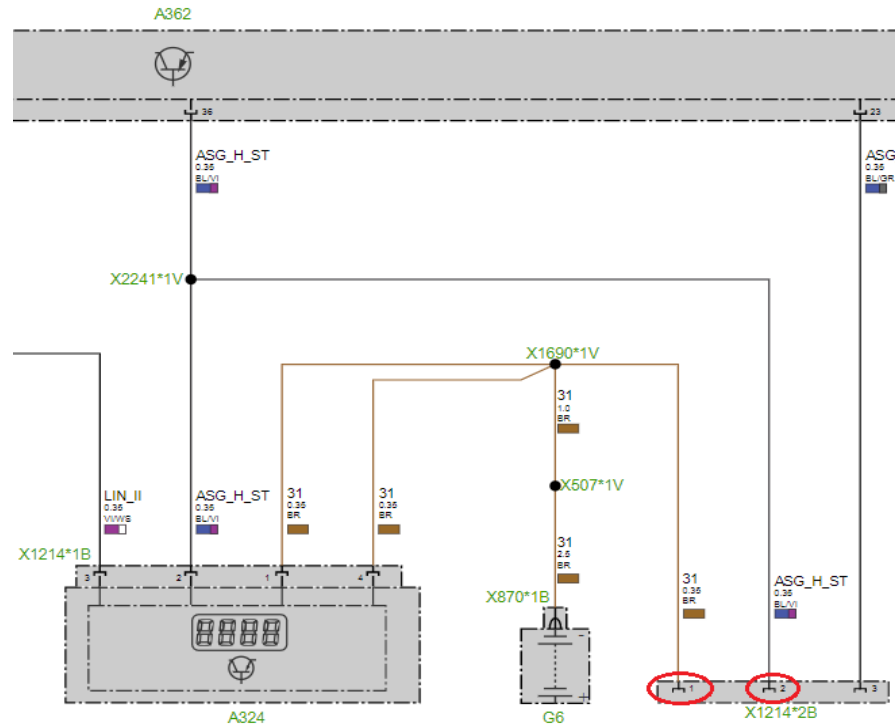

K59TU_SOFA_01

CUSTOMER LOAD ON OUTPUT OF REAR FOG LIGHT (GMSF PIN 47)

Requirement: No rear fog light may be installed; the SA573 must not be included in the vehicle order

KLNS: 12 V on Pin 47 GMSF (A362) on plug (E165*1B Pin2)

12 Volt power supply on rear fog light with pressing button „I“ (max. 2 Ampere; no after-run time)

Ground on plug E165*1B Pin 1

Correct connector plug (E165*1B):

- 8330 0402344 Repair plug (2-pin)
- or
- 6113 8366275 Pin housing (2-pin)
- 6113 8366269 Pin contact (0,5-0,75mm²)
- 6113 8366245 Single wire sealing
- 6113 8366249 Sealing grommet

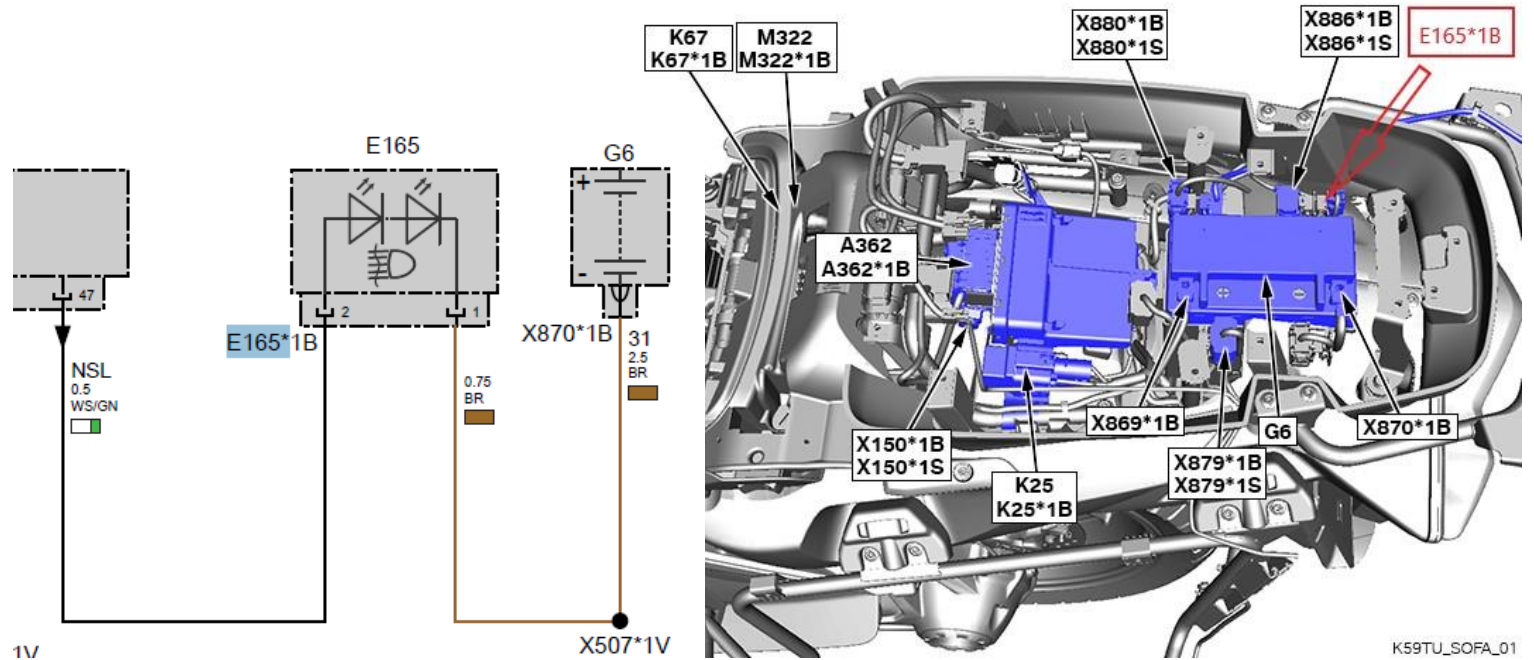

FLASHING WARNING LIGHTS HEADLIGHT (ALTERNATING HEADLIGHT)

The "Alternating headlight" can be set in 3 different frequencies (low beam and high beam are controlled alternately):

SB10: Flashing warning lights headlight 1 Hz

SB15: Flashing warning lights headlight 1,5 Hz

SB20: Flashing warning lights headlight 2 Hz

With active front flashing lights is the alternating headlight activated, when there is enough light (light sensor in the I-kombi)

Furthermore, the alternating front light can be switched off with a long press on the "J" key

For this function is following Ho-Word necessary:

AFAN: Do not save alternating frontal light state

or

AFAS: Save alternating frontal light state

(Softwarebug with US variant: can not be switched off with button „J“; Failure solved with I-level K001-21-07-500)



POWER SUPPLY FOR ELECTRICAL ACCESSORIES ON SA-PLUG WITH FRONT FLASHING LIGHTS

With active front flashing lights, a 12 volt power supply is also supplied to the SA plug

XK46: 12 V on Pin 46 GMSF (A362) to plug (X886*1B Pin 3)

Ground on plug X886*1B Pin 1

- Correct connector plug (X886*1B):
- 6113 8364625 Pin housing (6-pin)
- 6113 8366269 Pin contact (0,5-0,75mm²)
- 6113 8366245 Single wire sealing
- 6113 8366249 Sealing grommet

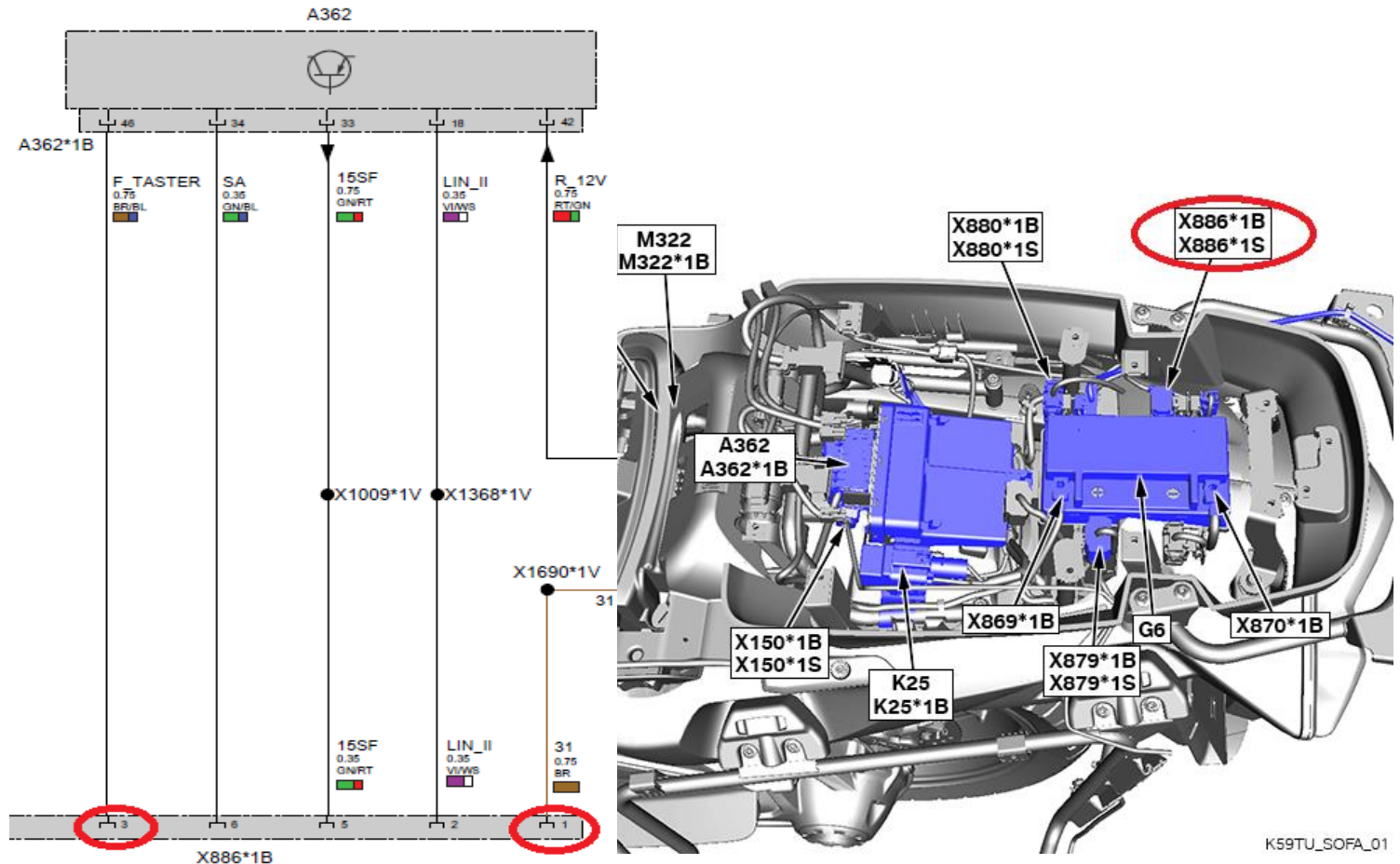

K59TU_SOFA_01

Bordnetz Sonderfahrzeug K52 MÜ



Laden:
Erhöhte Ladespannung eines Ladegerätes (>>12V) wird vom Steuergerät erkannt, sodass das Trennrelais geschlossen wird (beide Batterien werden geladen).

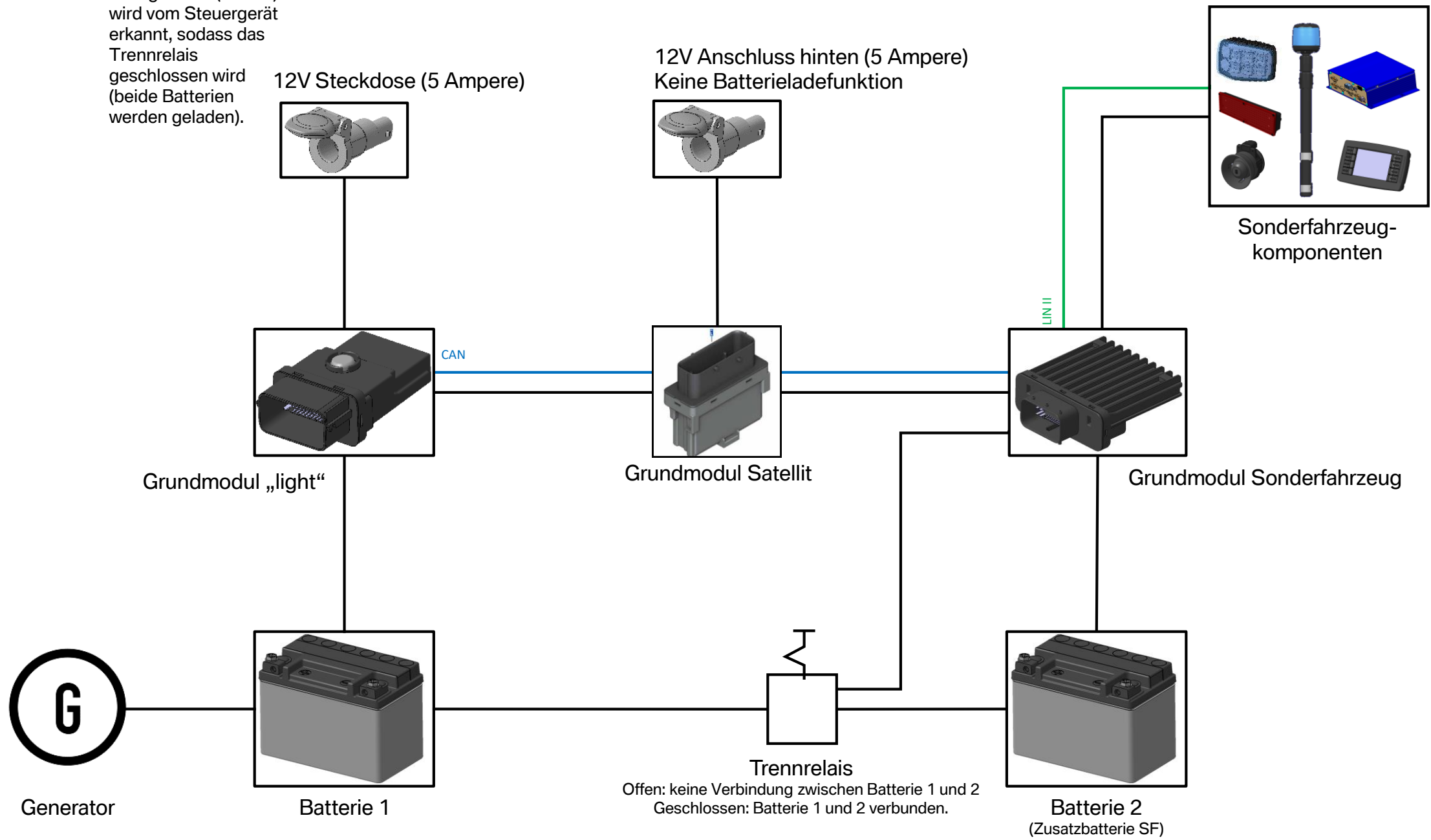

Laden:
Erhöhte Ladespannung (>>12V) wird vom Steuergerät erkannt, sodass das Trennrelais geschlossen wird (beide Batterien werden geladen).

Achtung:
Bei direktem Laden der Batterie 1 bei ausgeschalteter Zündung erkennt das Steuergerät keine Ladespannung. Das Trennrelais kann nicht geschlossen und die Batterie 2 nicht geladen werden.

Möglicher Fehler:
Bei Tiefenentladung der Batterie 2 ist kein Schließen des Trennrelais mehr möglich. Die Batterie 2 kann somit nicht mehr über den Generator bzw. die 12V Steckdose geladen werden. Batterie direkt an Polen oder Trennstecker laden.

— Stromleitungen
— Datenleitungen

Power circuit of authority vehicle K52 MÜ



Charging:
Increased charging voltage of a charger (>>12V) is detected by the controller and thus the split relay is closed (both batteries are charged).

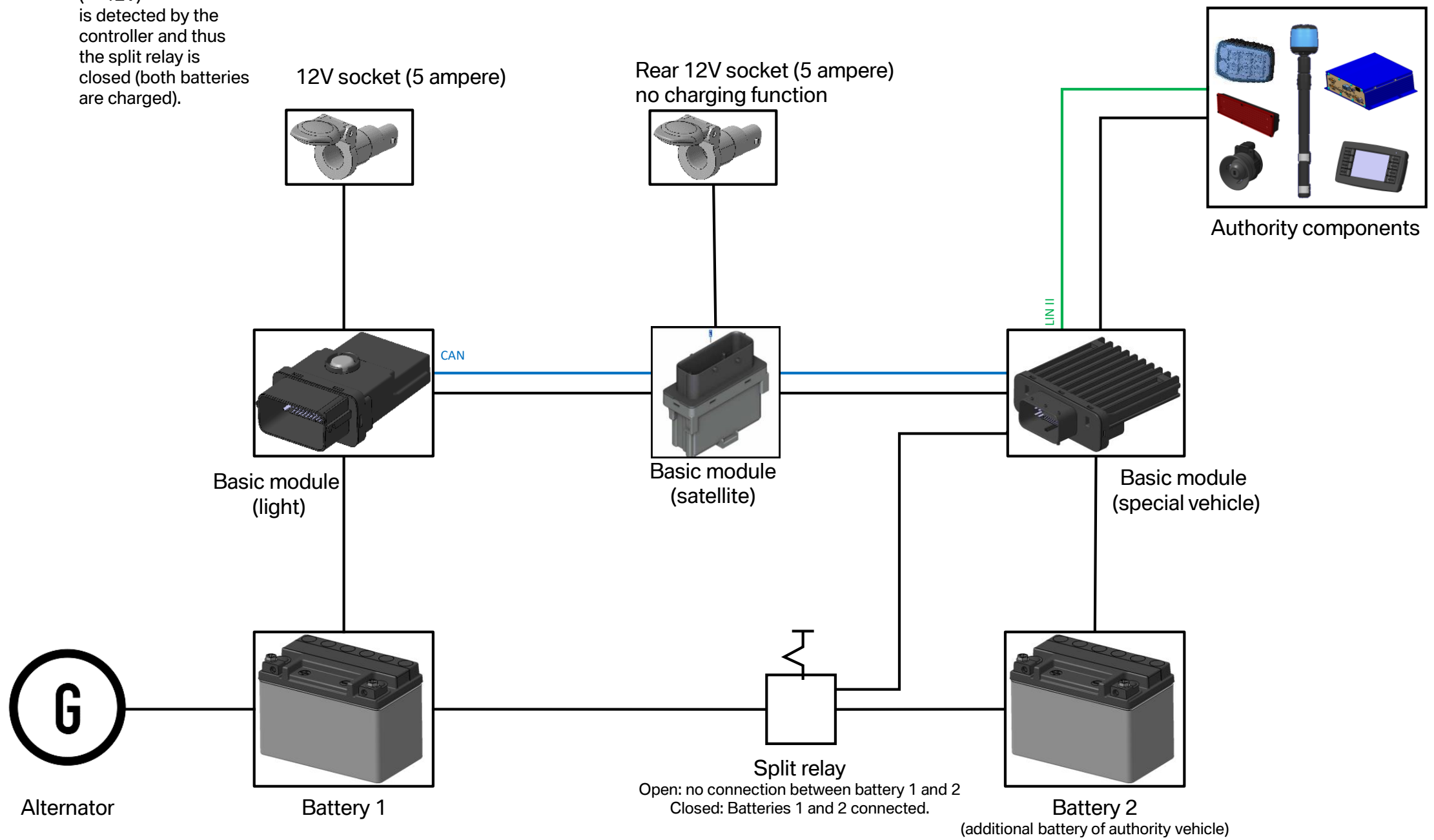

Charging:
Higher charging voltage (>>12V) is detected by the controller and thus the split relay is closed (both batteries are charged).

Attention:
When charging battery 1 directly (ignition switched off) the controller cannot detect the charging voltage. The split relay cannot be closed and the second battery will NOT be charged.

Possible errors:
If battery 2 is deeply discharged, the split relay cannot be closed. Therefore battery 2 can no longer be charged by alternator or socket. Battery must be charged directly at the poles or at the split connector.

— Power wiring
— Data wiring

Bordnetz Sonderfahrzeug



Laden:
Erhöhte Ladespannung eines Ladegerätes (>>12V) wird vom Steuergerät erkannt, sodass das Trennrelais geschlossen wird (beide Batterien werden geladen).

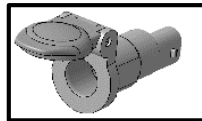

12V Steckdose

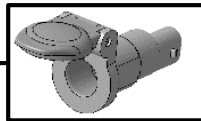

12V Steckdose
(nur K52/K52TÜ)

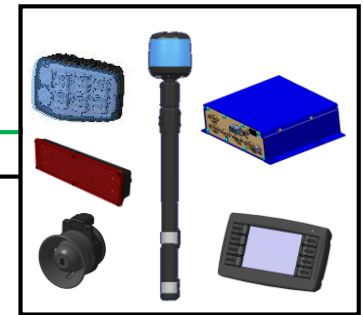

Sonderfahrzeugkomponenten

Grundmodul light

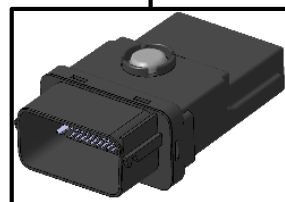

CAN

Grundmodul Sonderfahrzeug



LIN II



Generator

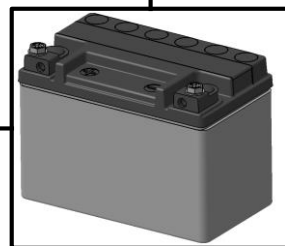

Batterie 1

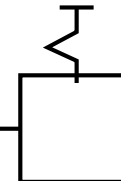

Trennrelais

Offen: keine Verbindung zwischen Batterie 1 und 2
Geschlossen: Batterie 1 und 2 verbunden.

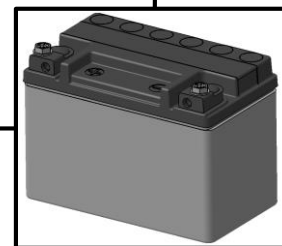

Batterie 2
(Zusatzbatterie SF)

Laden:
Erhöhte Ladespannung (>>12V) wird vom Steuergerät erkannt, sodass das Trennrelais geschlossen wird (beide Batterien werden geladen).

Achtung:
Bei direktem Laden der Batterie 1 bei ausgeschalteter Zündung erkennt das Steuergerät keine Ladespannung. Das Trennrelais kann nicht geschlossen und die Batterie 2 nicht geladen werden.

Möglicher Fehler:
Bei Tiefenentladung der Batterie 2 ist kein Schließen des Trennrelais mehr möglich. Die Batterie 2 kann somit nicht mehr über den Generator bzw. die 12V Steckdose geladen werden. Batterie direkt an Polen oder Trennstecker laden.

— Stromleitungen

— Datenleitungen

Power circuit of authority vehicle



Charging:
Increased charging voltage of a charger (>>12V) is detected by the controller and thus the split relay is closed (both batteries are charged).

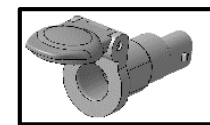

12V socket

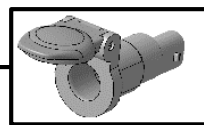

12V socket (only K52/K52TÜ)

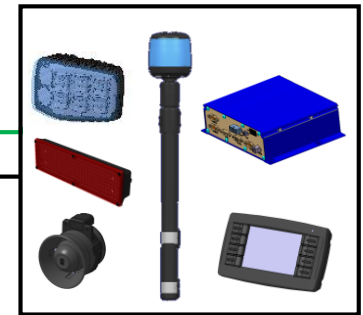

Authority components

Basic module (light)

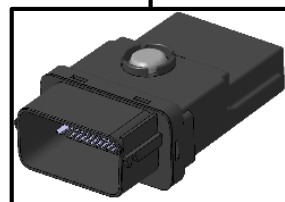

CAN

Basic module (special vehicle)



LIN II



Alternator

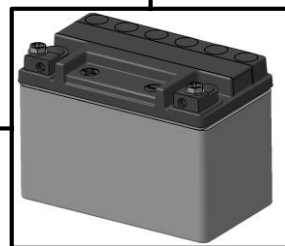

Battery 1

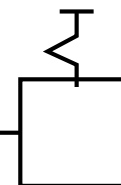

Split relay

Open: no connection between battery 1 and 2
Closed: Batteries 1 and 2 connected.

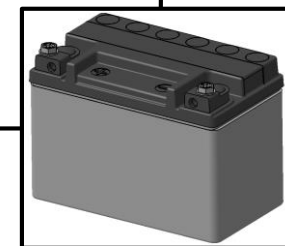

Battery 2 (additional battery of authority vehicle)

Charging:
Higher charging voltage (>>12V) is detected by the controller and thus the split relay is closed (both batteries are charged).

Attention:
When charging battery 1 directly (ignition switched off) the controller cannot detect the charging voltage. The split relay cannot be closed and the second battery will NOT be charged.

Possible errors:
If battery 2 is deeply discharged, the split relay cannot be closed. Therefore battery 2 can no longer be charged by alternator or socket. Battery must be charged directly at the poles or at the split connector.

— Power wiring
— Data wiring