



## Vehicles Chassis Equipped With Bendix Brakes On Steer Axle - Excessive Brake Noise; FSB 514-001, Brake S-Cam, Replacement



> Internal Content

The current version of FSB 514-001 can be found in Impact under the Service tab.

- The Operation can be found under [Function Group 514](#), Operation [5143-03-09-01 FSB 514-001, Brake S-Cam, Replacement](#).
- If the article does not appear when searched with either VIN or Chassis information entered, search by model:

1. Clear any chassis information from the Search box.
2. Select or enter the proper model.

Search

Chassis series Chassis No.

VIN

CXU

Function group

3. Set the Function Group to 514 and make sure Info Type is set to All Service Information.

514. Brake cam

Info type

All Service Information

4. Press the Search button. A list of operations will appear in the results window. Choose the correct article.

Service Search - Model CXU Function group 514

Fgrp ▲	Title ▼	Info type ▼	ID/Operation ▼
500	General Safety Practices	Repair	
510	Brake Literature	Bulletins/Information	
514	FSB 514-001, Brake S-Cam, Replacement	Repair	5143-03-09-01
514	Slack Adjuster	Service and maintenance	
514	Slack Adjuster, Replacement	Repair	5141-03-02-04

5. A box will display with applicable models. Select the correct chassis description.

• **Note:** At the time of this Solution's publication, there is only one option in the chassis description menu as seen below.

FSB 514-001, Brake S-Cam, Replacement ✕

Tags

Description	ID	Date
k85205915	RM-E	2017
fsb 514-001		

k85205915
s-cam
brake noise
brake squeal

fsb 514-001
bendix
mack
volvo

## Related links and attachments

No links or attachments available

## Feedback

[Give feedback](#)

to help improve the content of this article

(June 2018)

Some VOLVO VN trucks built after 05/13/2013, equipped with Bendix Brake S-Cams on the steer axle may require replacement to reduce or eliminate brake noise during braking. The replacement procedure includes installation of a new tuned brake S-Cam shaft, spring & roller kit, and seal & shim kit. Follow the S-Cam replacement procedure outlined in this Field Service Bulletin (FSB).

*Note: For replacement, use the 10 spline Brake S-Cam shaft for trucks built from 05/13/2013 to 07/09/2017. See reference image of 10 spline brake S-Cam (1) in figure below.*

*Note: For replacement, use the 28 spline Brake S-Cam shaft for trucks built from 07/10/2017. See reference image of 28 spline brake S-Cam (2) in figure below.*

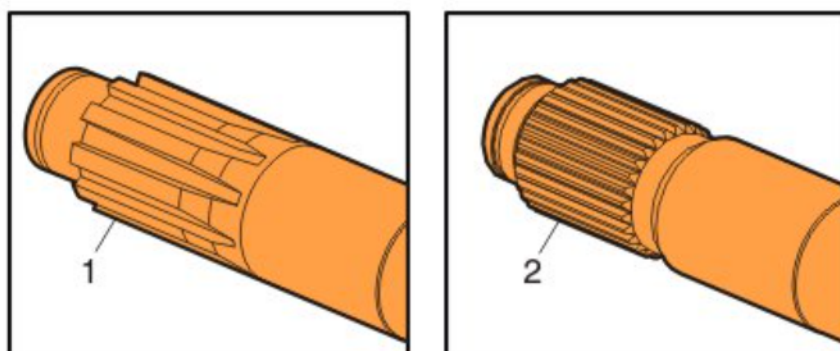

## Bendix Tuned S-Cam Description

*Note: The Bendix Tuned S-Cam shaft is “Only” designed to reduce/or eliminate brake noise heard within the 1200 to 1500 Hertz frequency range. Submission of a video or audio file with the tech support case will assist in the diagnosis of any brake noise concern.*

The Bendix Tuned S-Cam is designed to reduce and/or eliminate brake noise heard within the 1200-1500 Hertz frequency range. Although the tuned S-Cam may help reduce brake noise heard in other frequency ranges, it is only designed to effectively reduce the noise range between 1200-1500 Hz. Proper installation and clearance of the Bendix tuned S-Cam is very important. To ensure the best results in noise reduction follow all steps within this FSB. Below is an example Hertz graph of the Bendix brake noise.

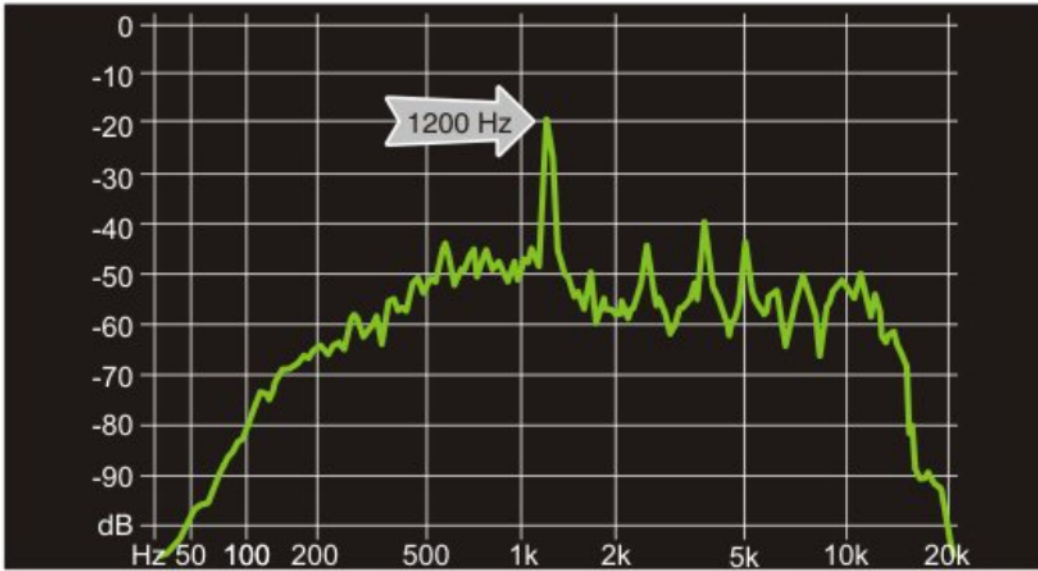

## Verifying Noise

A Tech Support/E-Service case will need to be submitted to verify that the Bendix brake noise is within the Frequency Range that the new tuned S-Cam is designed to correct. To verify the Bendix brake noise the truck may need to be test driven and the front steer axle brakes heated up to 300° Fahrenheit then let cool to 150° Fahrenheit. Most Bendix brake noise complaints can be duplicated after brakes are heat cycled and then test driven using 15-25 psi brake applications. Tech Support may ask that a video or sound file be taken and uploaded to the case for verification. A valid Tech Support/E-Service case number will be needed when ordering parts.

## Parts Ordering

To schedule parts orders and repairs, please call (877) 986-5862 with a valid Tech Support/E-Service case number and VIN number of the vehicle in need of this repair.

*Note: Example Tech Support/E-Service Case Number (1-XXXXXXXXXX).*

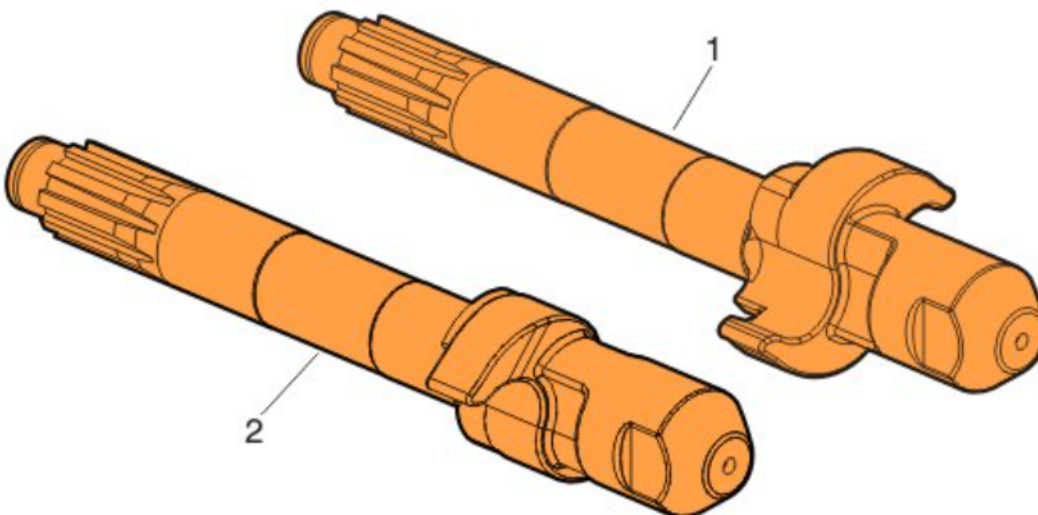

10-Spline Camshaft (For Trucks Built From 05/13 /2013 to 07/09/2017)			
Item	Description	Part Number	Qty
1	Camshaft, Tuned Mass,	85150135	1

Copyright to this documentation belongs to the Volvo Group. No reproduction, copying, change, amendment or other similar disposal is entitled without prior written consent by the Volvo Group

The information contained herein is current at the time of its original distribution, but is subject to change. The reader is advised that printed copies are uncontrolled.



	CW, 10SPLINE		
2	Camshaft, Tuned Mass, CCW , 10SPLINE	85150134	1
3	Spring Kit	85153537	2
4	Hardware Module Kit	85153464	1

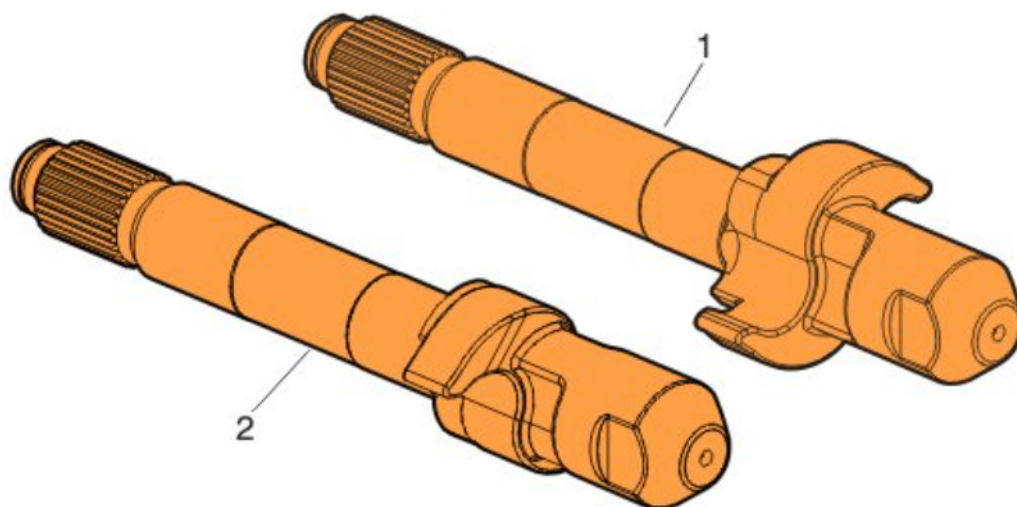

28-Spline Camshaft (For Trucks Built From 07/10 /2017)			
Item	Description	Part Number	Qty
1	Camshaft, Tuned Mass, CW, 28SPLINE	22880282	1
2	Camshaft, Tuned Mass, CCW , 28SPLINE	22880283	1
3	Spring Kit	85153537	2
4	Hardware Module Kit	85153464	1

## Decommissioning the Truck for Repair

You must read and understand the precautions and guidelines in Service Information, group 50, "General Safety Practices, Brakes" before performing this procedure. If you are not properly trained and certified in this procedure, ask your supervisor for training before you perform it.

**NOTE:** Information is subject to change without notice. Illustrations are used for reference only and can differ slightly from the actual vehicle being serviced. However, key components addressed in this information are represented as accurately as possible.

- . Park the vehicle on a flat and level surface.
- . Apply the parking brake.
- . Place the transmission in neutral or park.
- . Install the wheel chocks.

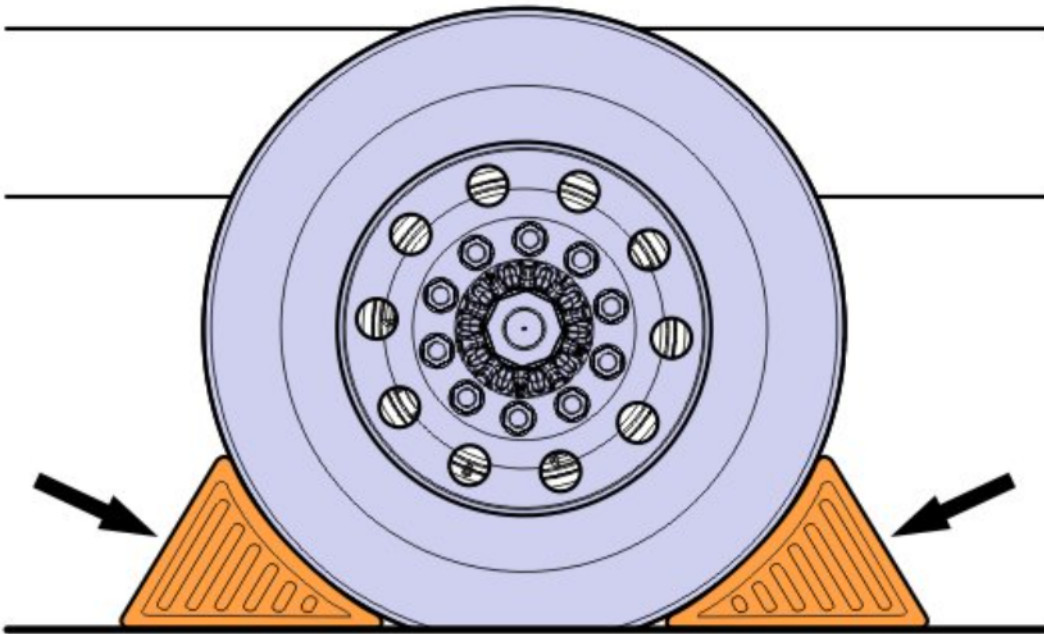

Disconnect the cable from the battery's negative terminal.

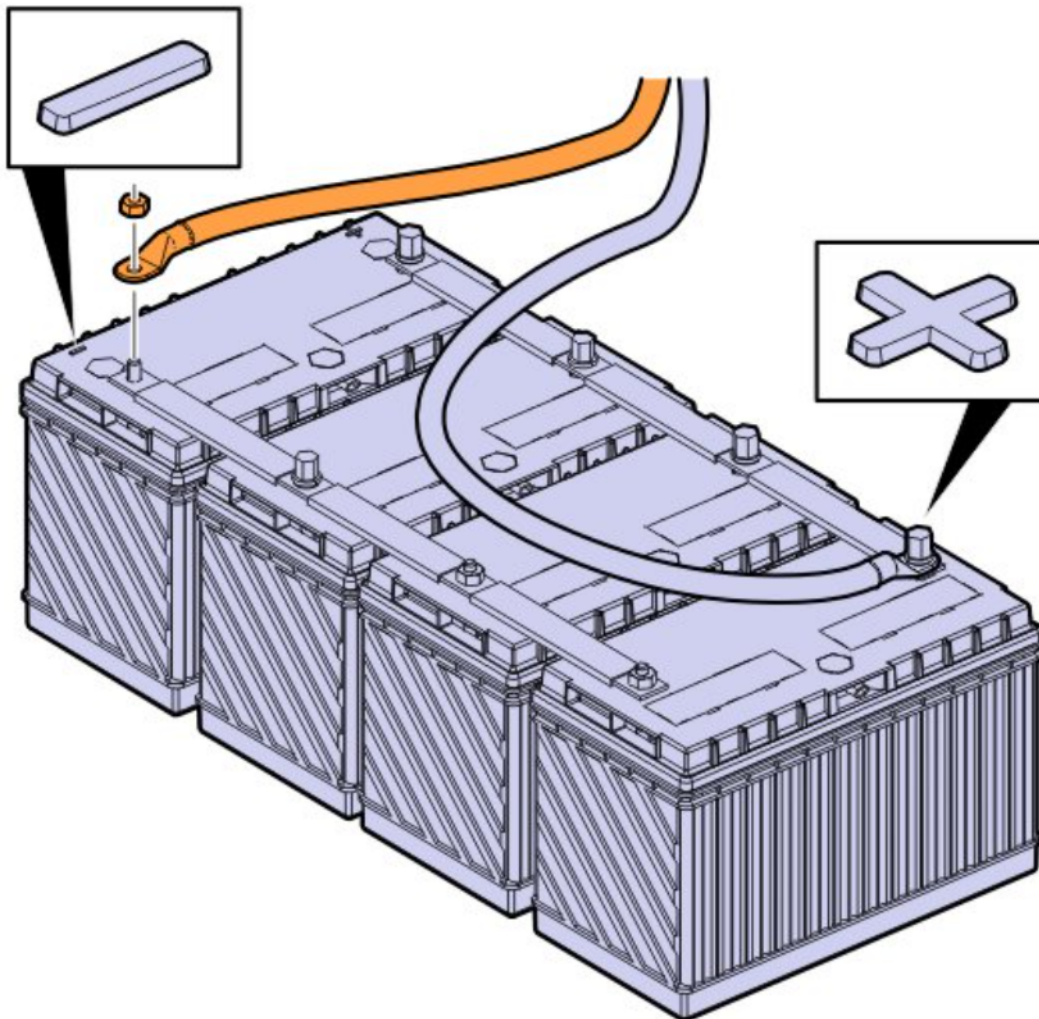

## Brake S-Cam Removal

*Note: The left side is shown for instructional purposes.*

- . Lift the steer axle with a jack, place the truck on jack stands, and remove the jack.
- . Remove the wheel nuts.

*Note: Before removing the wheel, mark the end of one wheel stud with a paint marker and mark the wheel at the stud to ensure the wheel is reinstalled in the same position.*

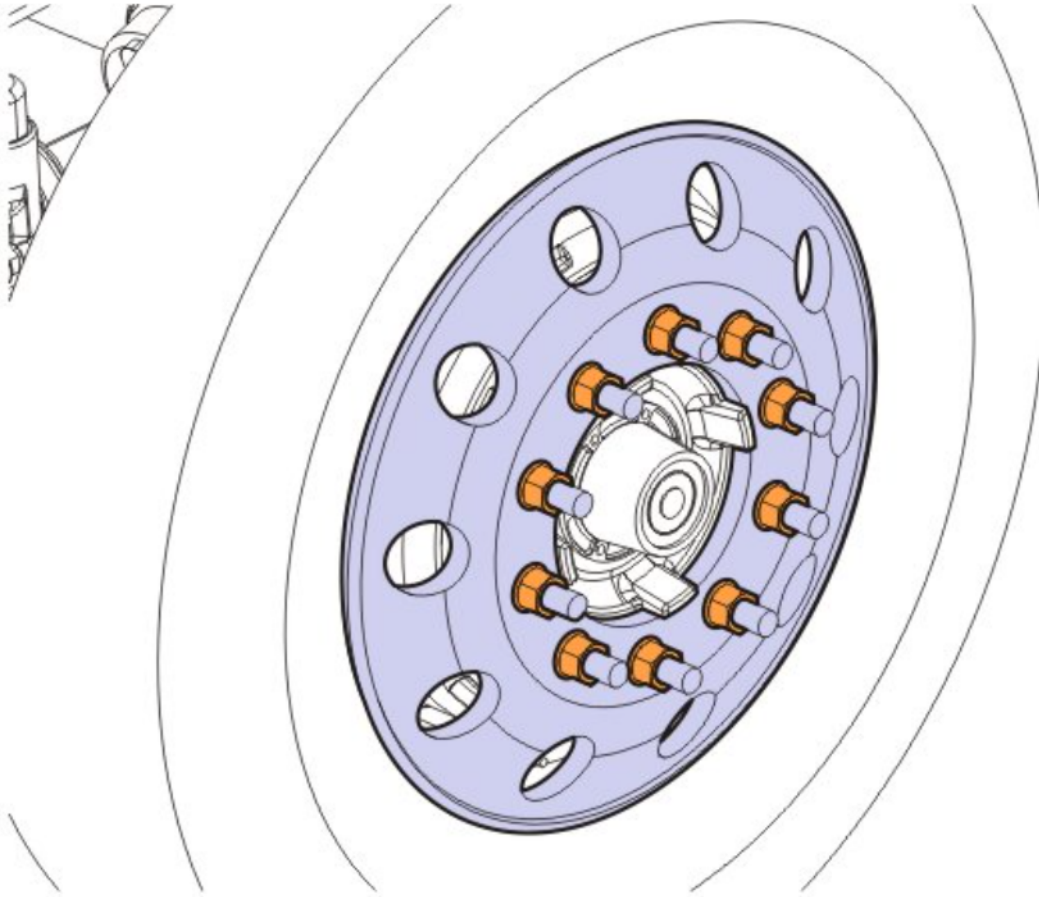

- . Remove the wheel.

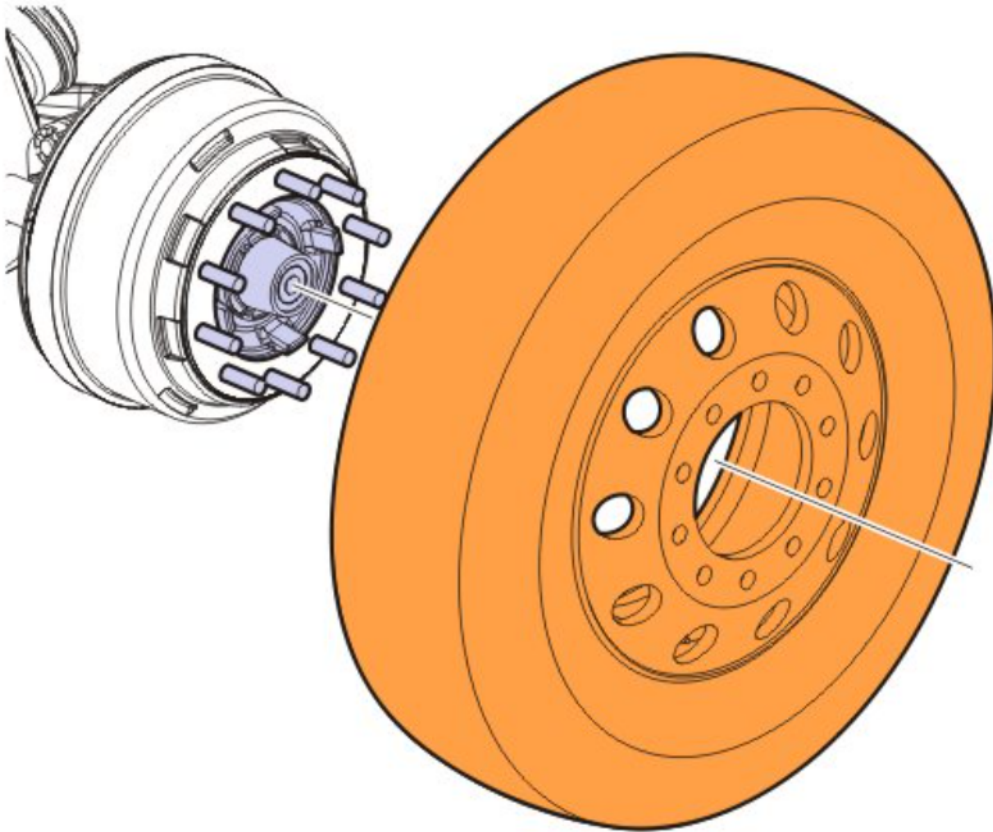

- . With the wheel removed, match mark the drum to the wheel stud to ensure the drum can be reinstalled in the same position.
- . Mark the brake shoes to ensure they can be reinstalled in the same position (top or bottom).
- . If applicable, remove the slack adjuster pawl.



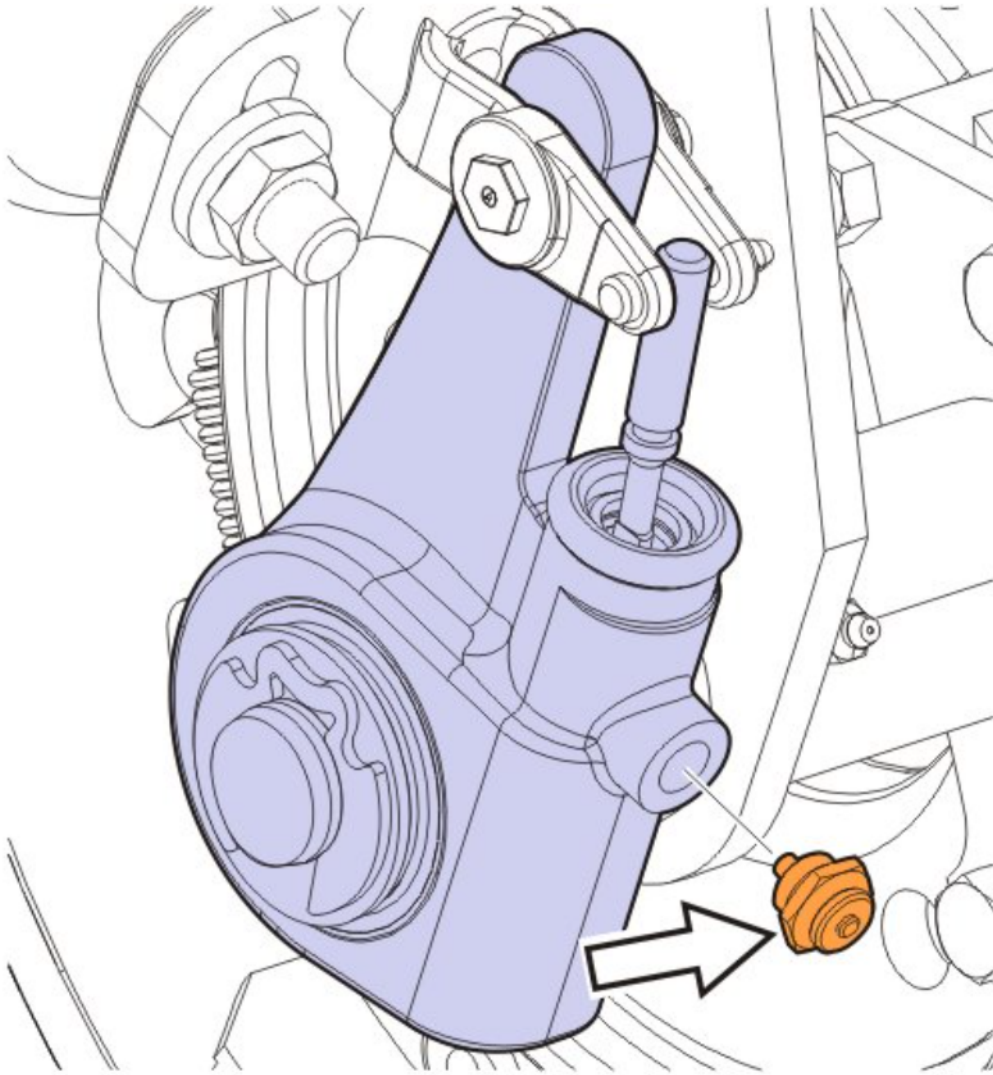

. Back off of the brake (slack adjuster).

*Note: The Meritor slack adjuster is shown in this procedure for backing off the brakes. However, this procedure is similar for other brands.*

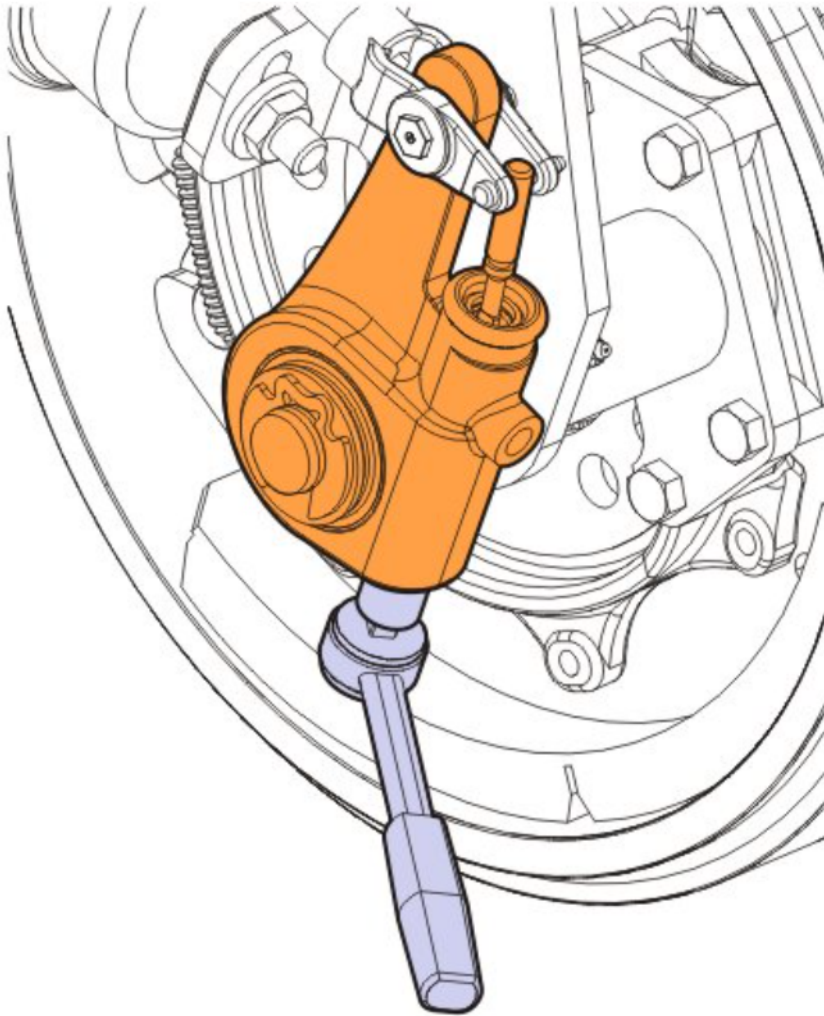

Remove the brake drum.

*Note: Clean the brake drum of any dust or debris and store for installation.*



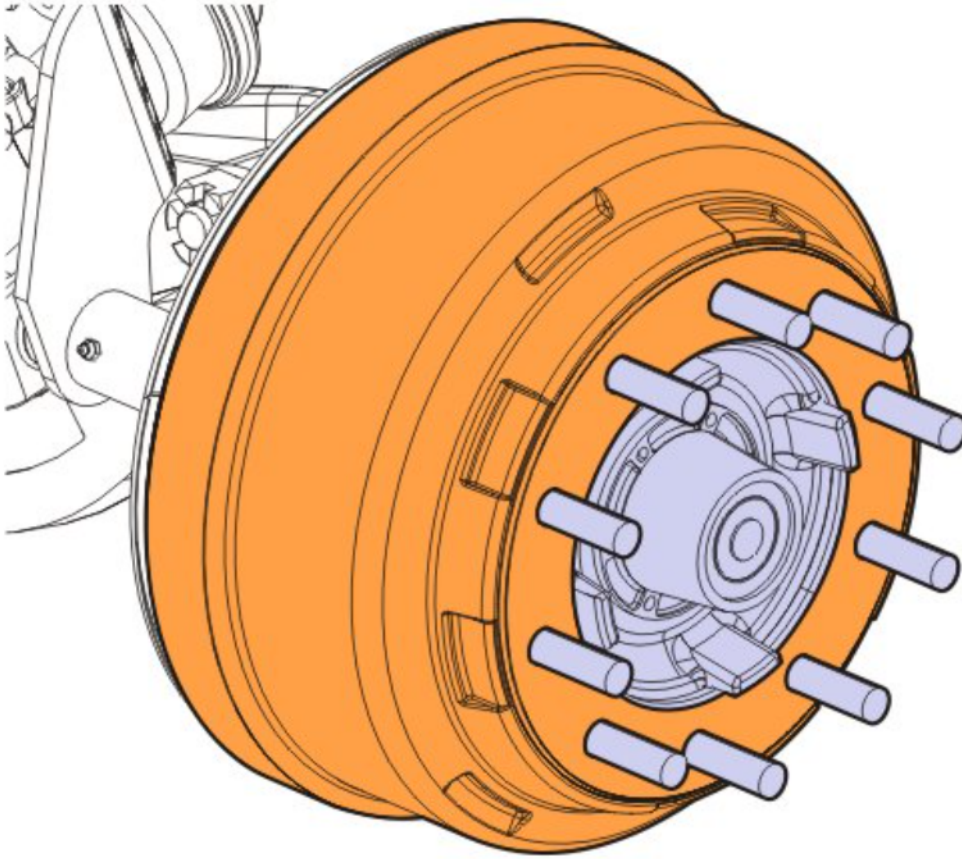

- Remove the brake shoes, brake springs, and rollers.

*Note: Clean the brake shoes of any dust or debris and store for installation.*

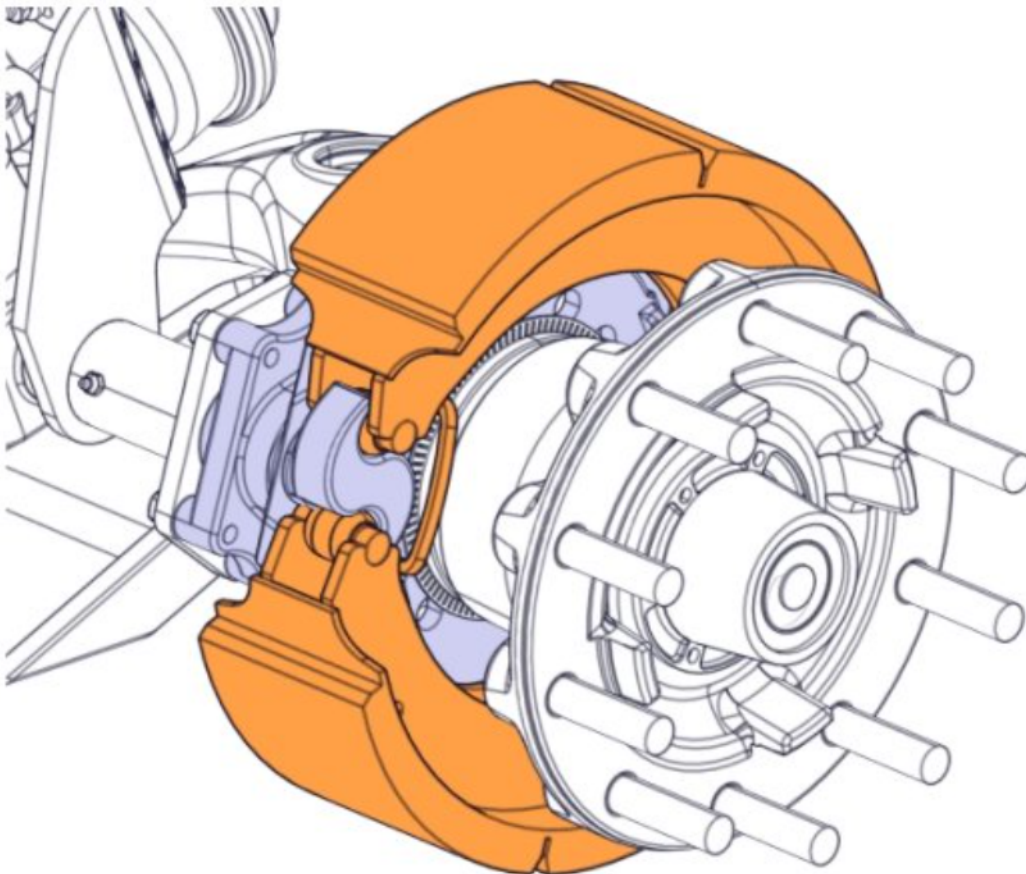

- Loosen the two nuts securing the brake chamber to the cam tube mounting bracket.

Copyright to this documentation belongs to the Volvo Group. No reproduction, copying, change, amendment or other similar disposal is entitled without prior written consent by the Volvo Group

The information contained herein is current at the time of its original distribution, but is subject to change. The reader is advised that printed copies are uncontrolled.

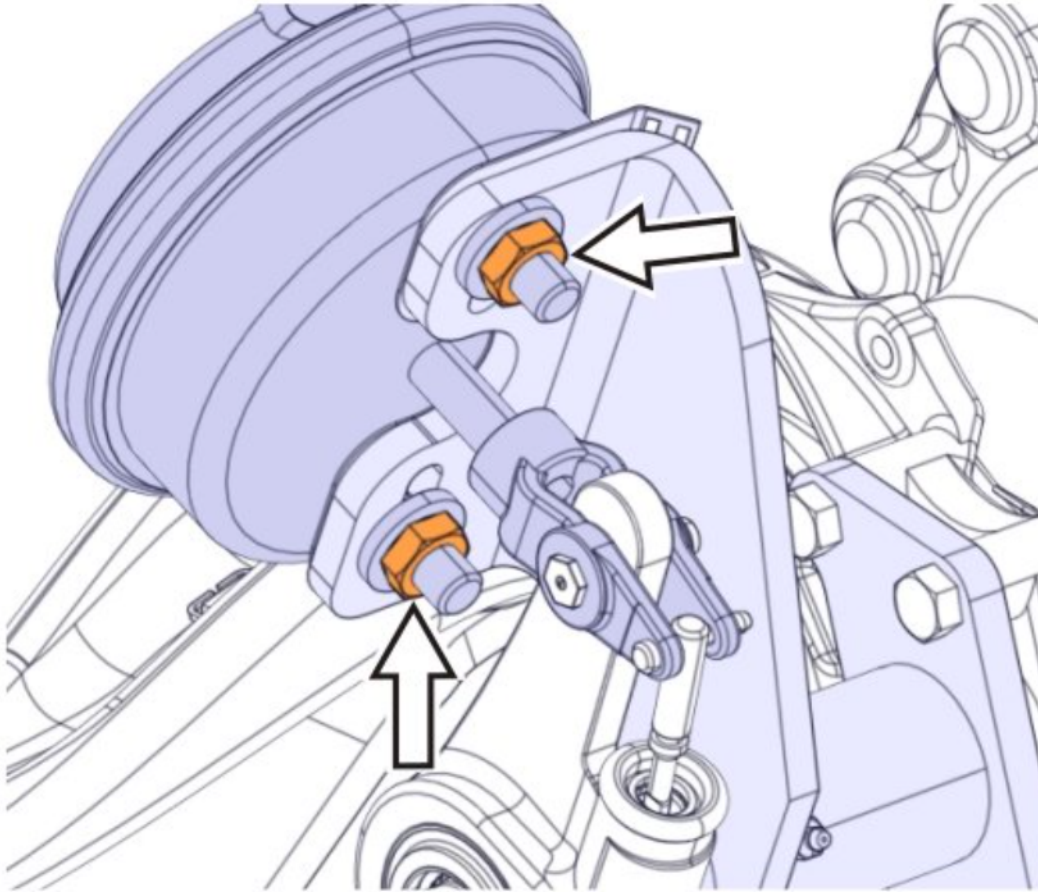

- For Haldex slack adjusters, remove the fasteners securing the slack adjuster to the cam tube mounting bracket.

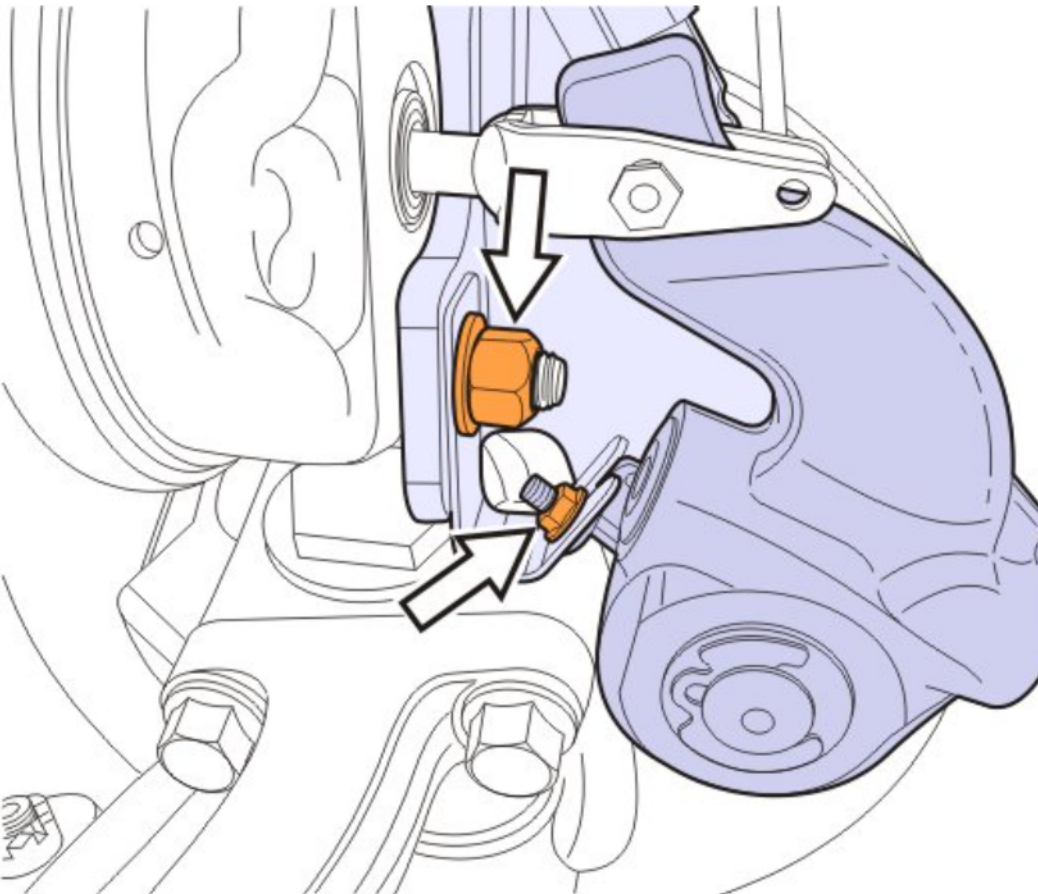

- Remove the snap ring and washers securing the slack adjuster to the brake S-Cam.



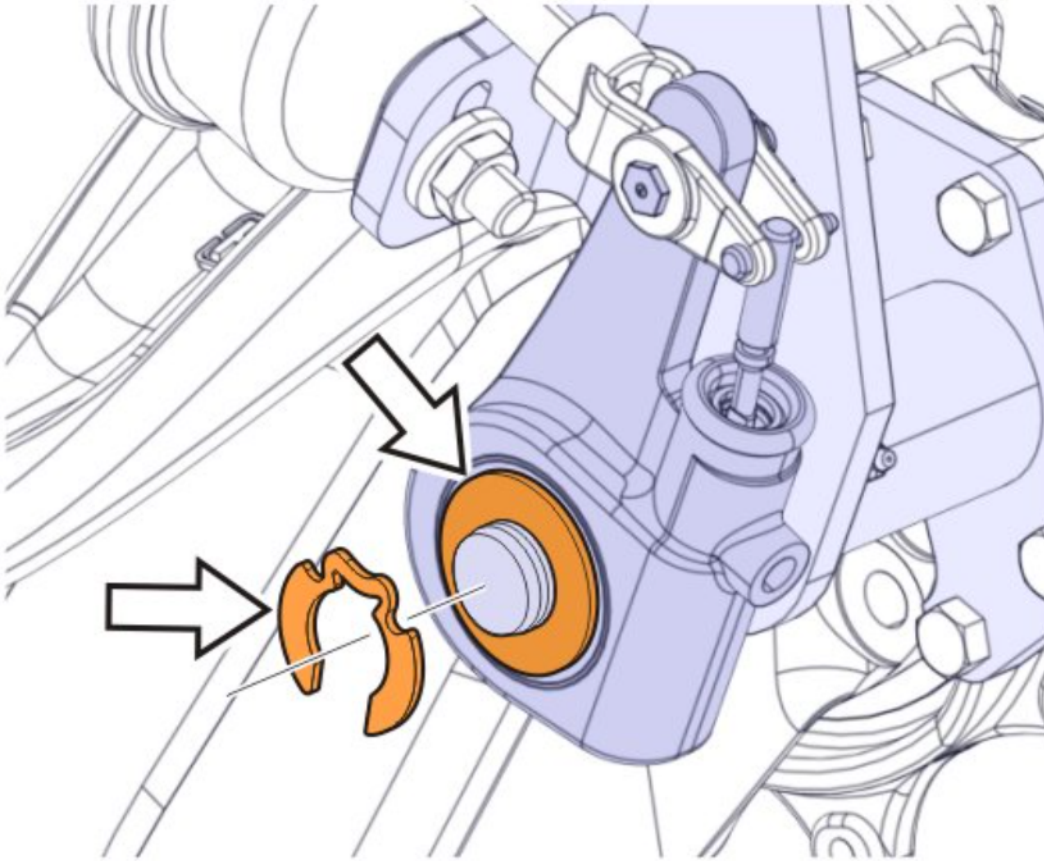

- Remove the four nuts and washers securing the cam tube to the brake spider.

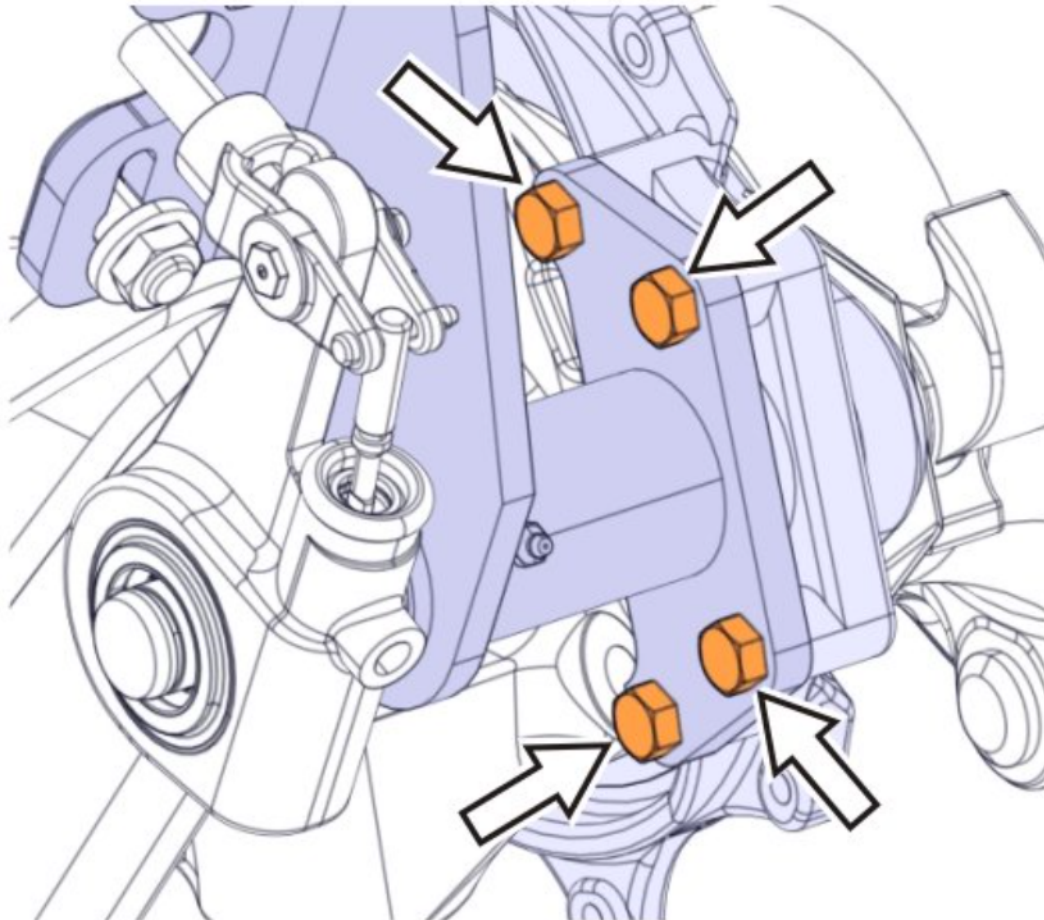

- Remove the brake S-Cam by pulling the S-Cam clear of the cam tube and brake spider.

*Note: Remove brake S-Cam head washer (2) from the removed S-Cam (1). Clean the head washer and store it for reuse.*

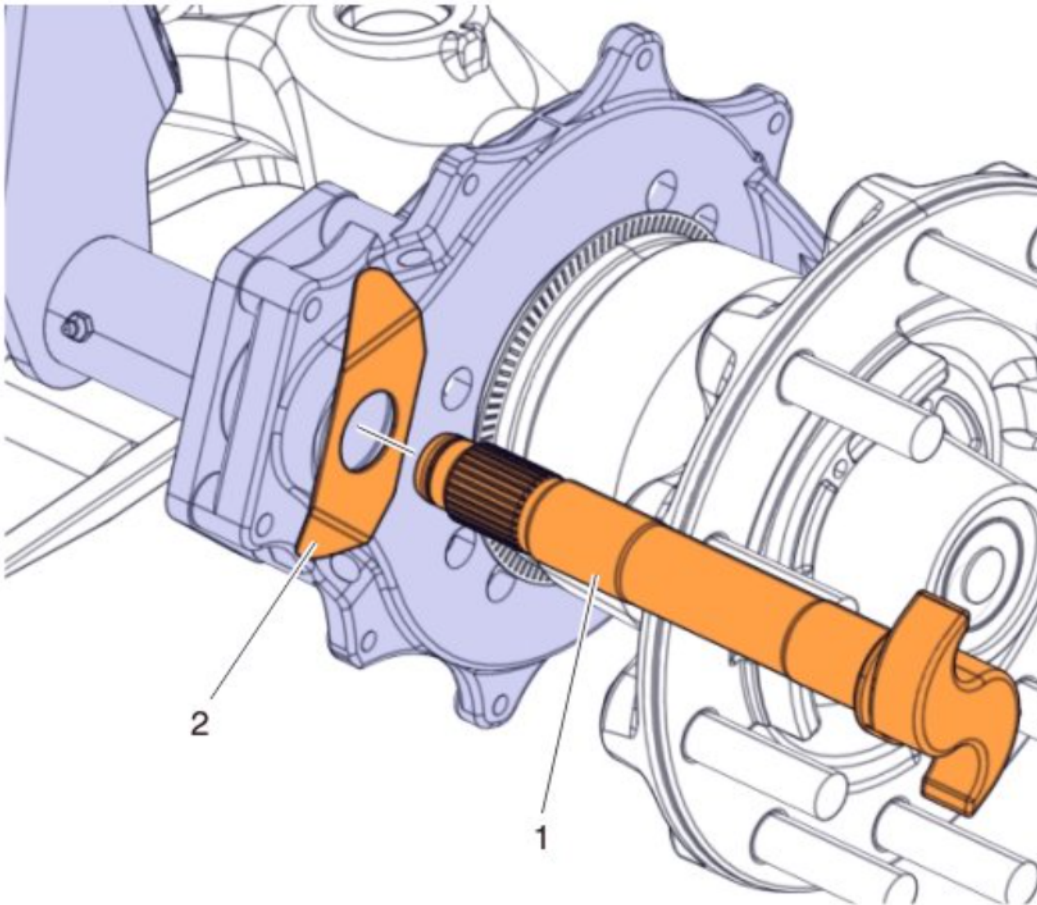

- Follow steps 2 through 14 for the right side of the truck.

## Brake S-Cam Installation

*Note: The left side is shown for instructional purposes.*

- Inspect the cam tube. Ensure the grease seals and bushing are good.

*Note: Replace the grease seals and/or bushings if needed.*

- Retrieve the stored S-Cam head washer (2) and install it on the replacement S-Cam (1) in the proper direction.



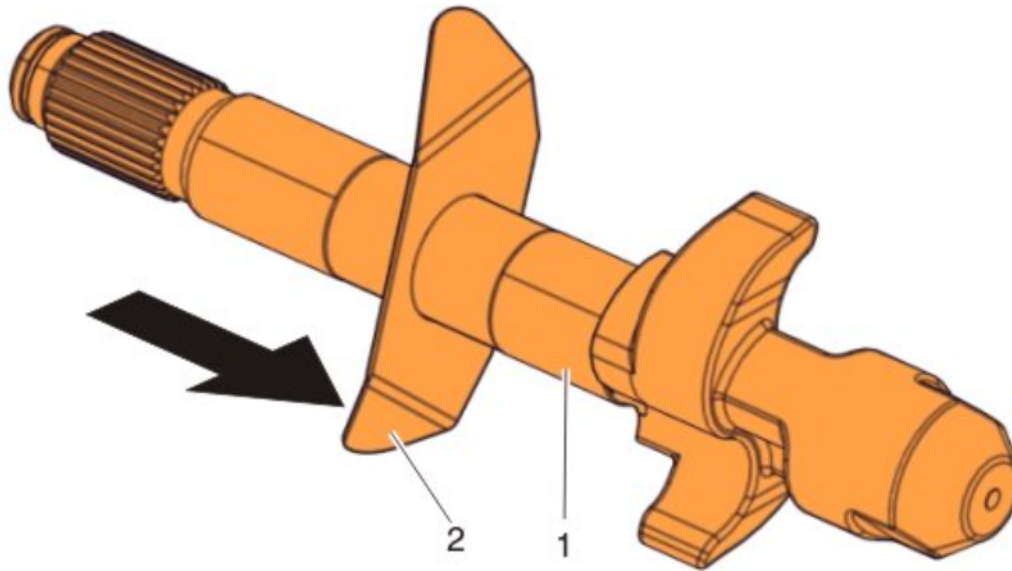

- . Lube the replacement S-Cam before installing it in the cam tube.
- . Position the S-Cam in the cam tube and slide it into the brake spider.

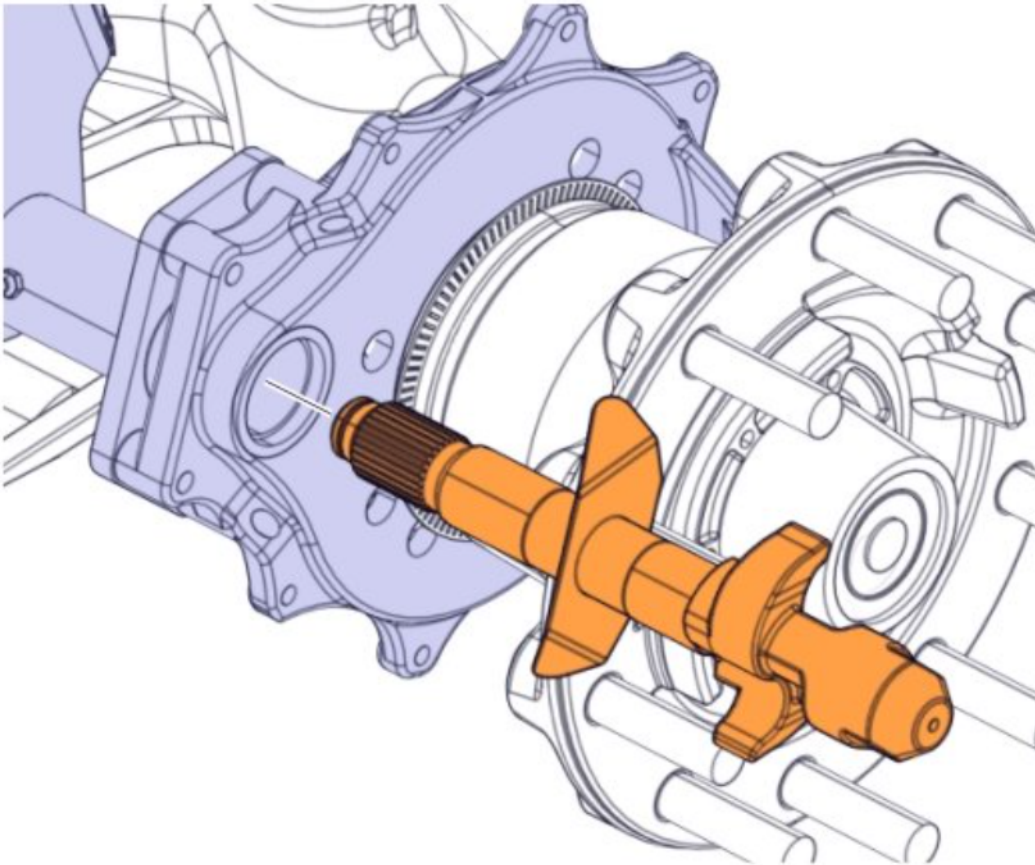

- . Install the four nuts securing the cam-tube and brake S-Cam to the brake spider.
- . Tighten the four nuts to 75 ft-lbs (102 N m).

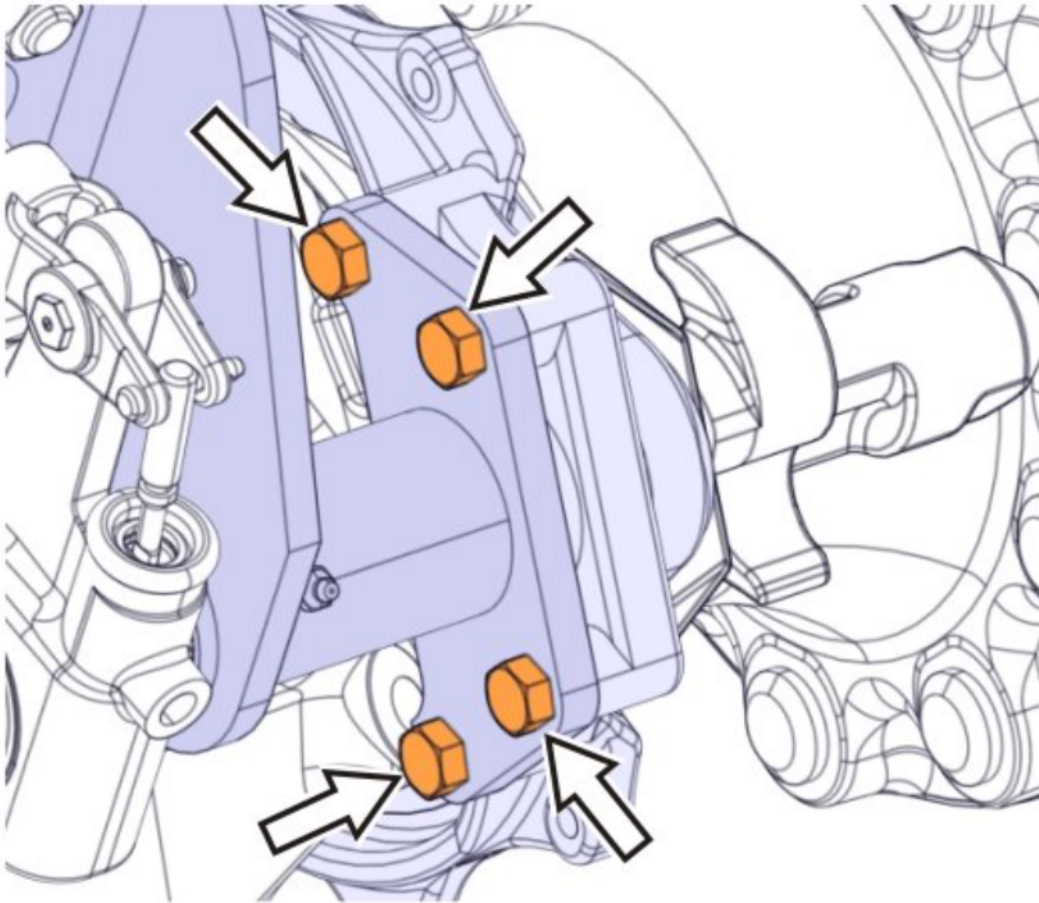

- . Properly position the slack adjuster on the replacement S-Cam.
- . Install the shim washer on the S-Cam, slack adjuster, and shim S-Cam to set the lateral end play 0.127 – 0.635 mm (.005-.025 in).
- . Install the E-clip.

*Note: Ensure the E-clip is in the groove at the end of the S-Cam.*



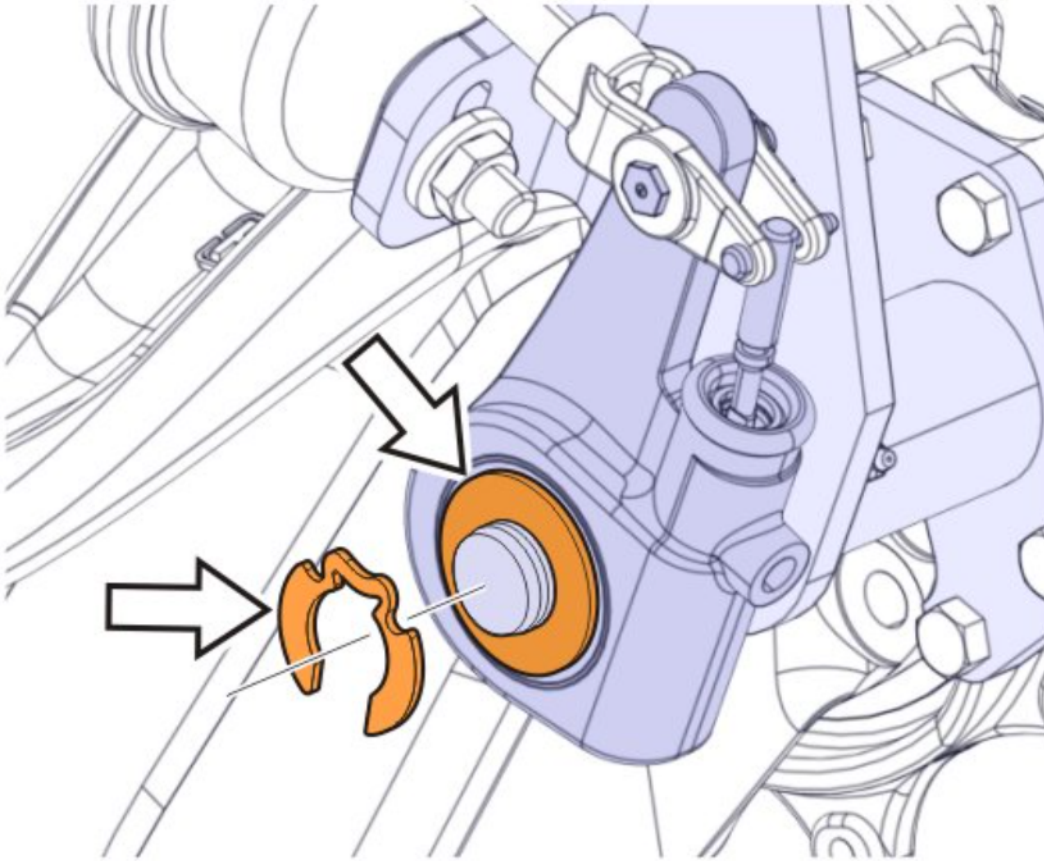

- . Measure the cam bushing play.

*Note: The maximum S-Cam bushing vertical end play permitted is (0.035 in).*

- . Tighten the two nuts securing the brake chamber to the cam tube mounting bracket.

*Note: On the first pass, tighten the two nuts to 34 Nm (25 ft-lb).*

*Note: On the second pass, tighten the two nuts to 180 – 210 Nm (133 – 154 ft-lb).*

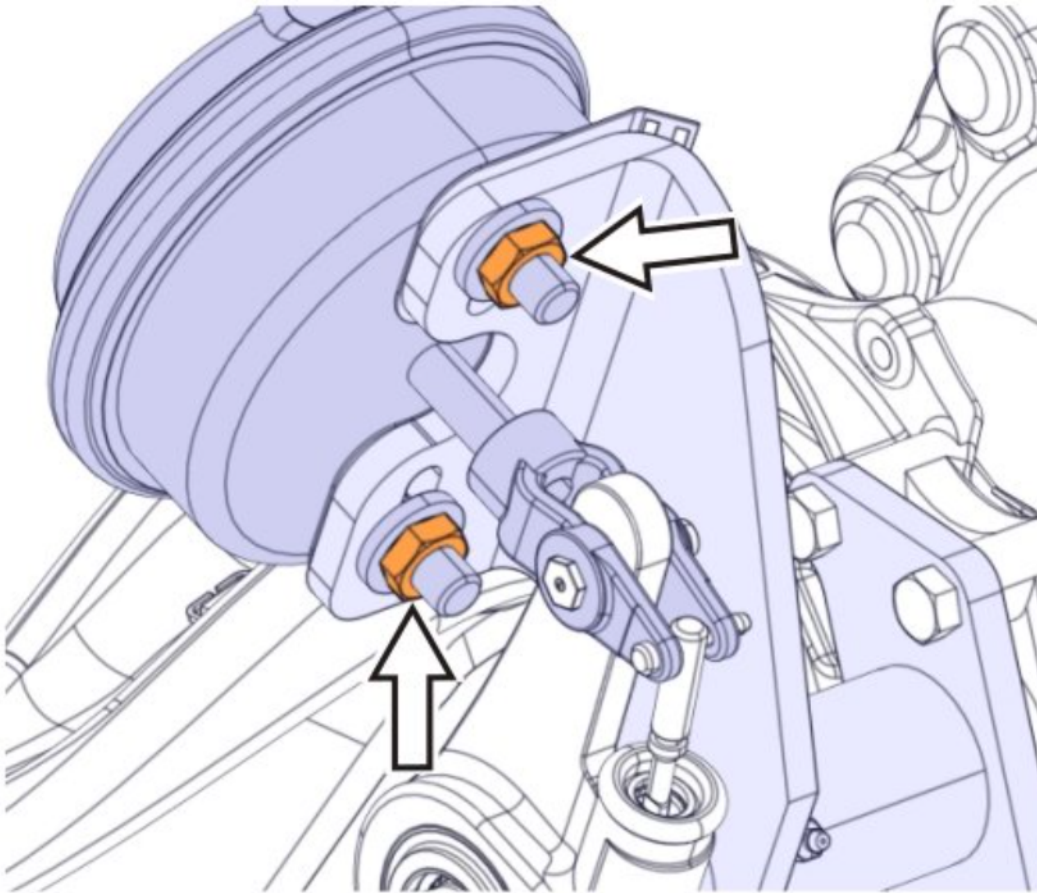

- . For Haldex slack adjusters, install the fasteners securing the slack adjuster to the cam tube bracket.
- . Tighten the slack mounting strap fastener to 11 – 16 Nm (8 – 12 ft-lb).

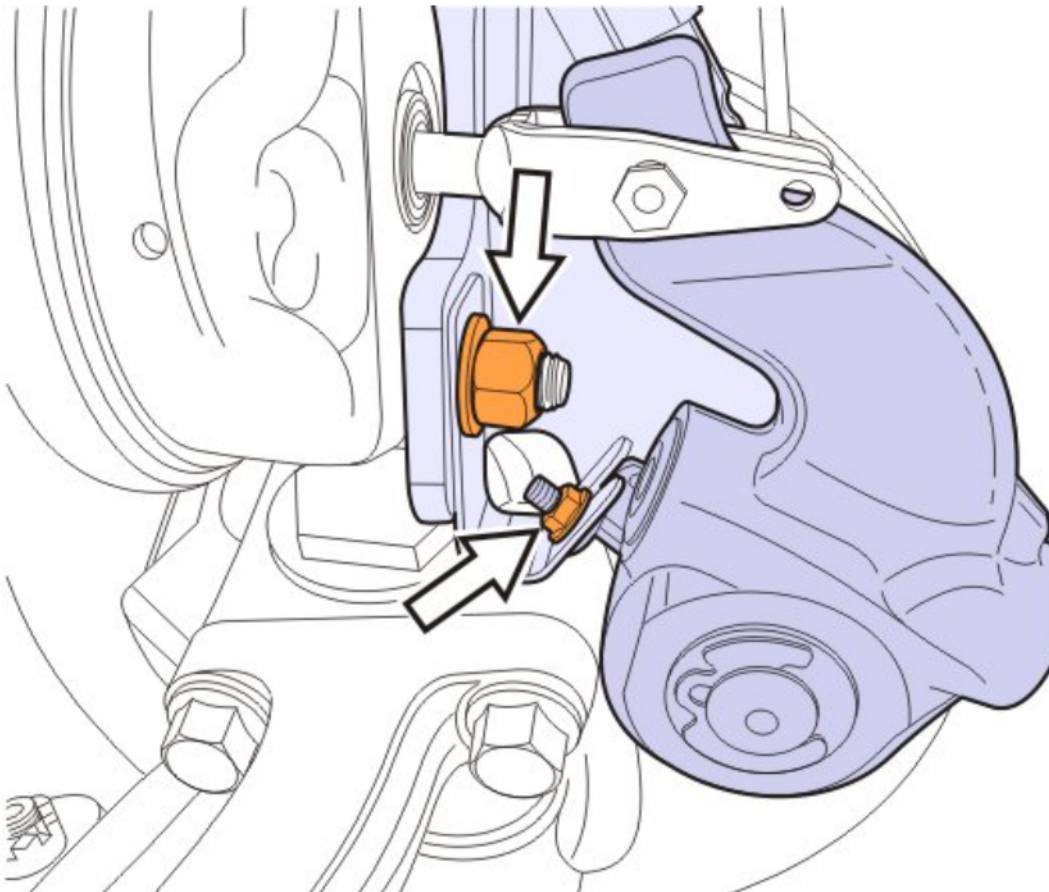

- . Using a grease gun, grease the cam tube and slack adjuster until they purge.

*Note: Ensure the grease seal at the S-Cam head does not leak. If it does leak, replace the seal.*

- . Pre-lube the rollers and anchor pin pockets on the brakes before installing brake shoes.
- . Install the brake shoes, springs and rollers in the same position (top or bottom) as previously recorded.

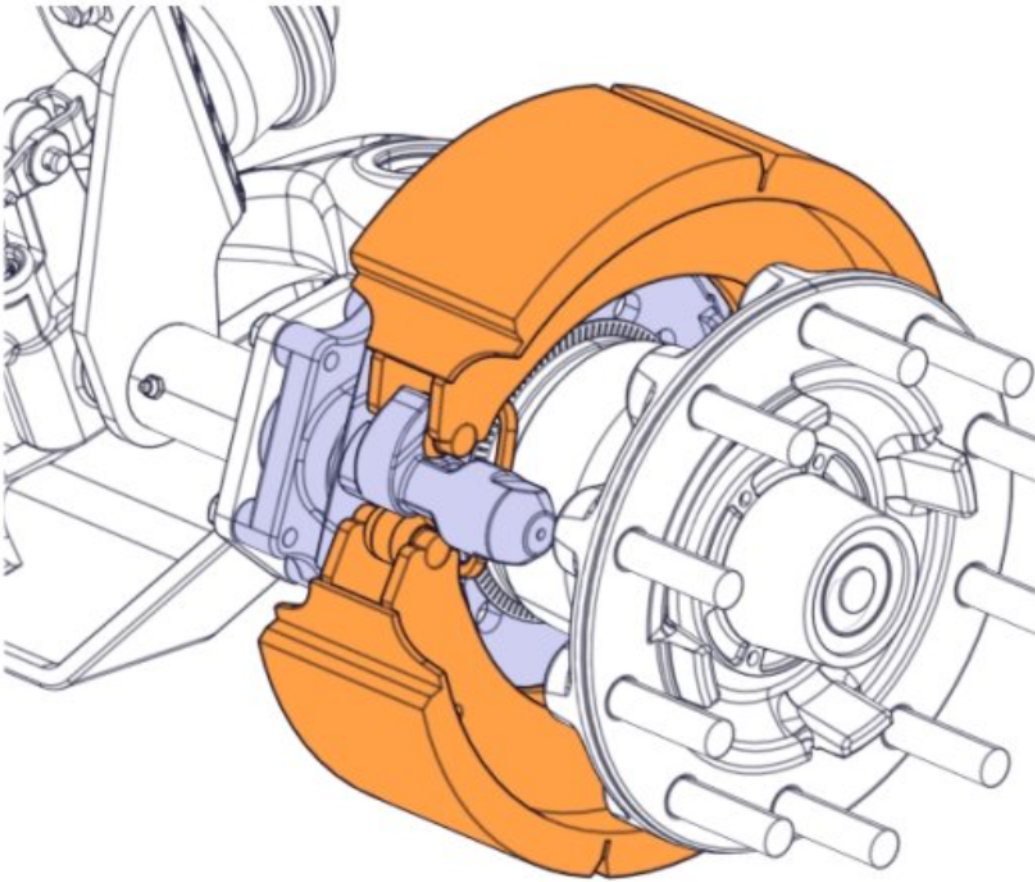

- . Install the brake drum as previously recorded on the drum and wheel stud during the removal procedure.



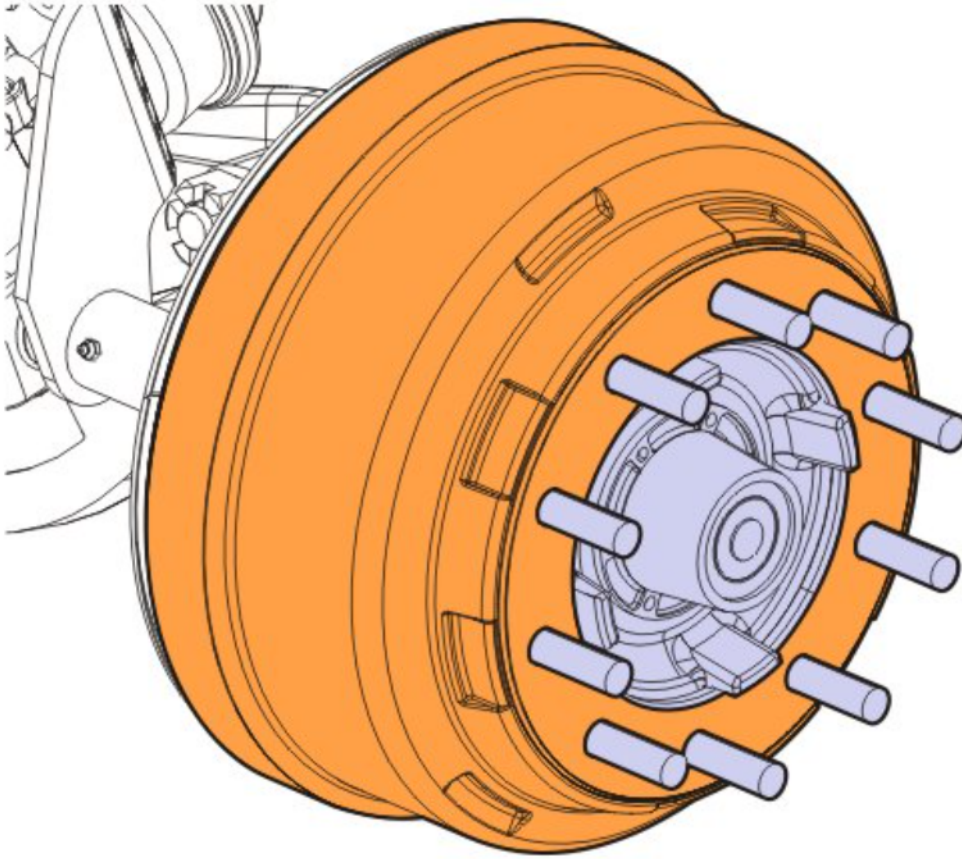

- . Install the wheel using the reference marks made on the wheel and the wheel stud during the removal procedure.

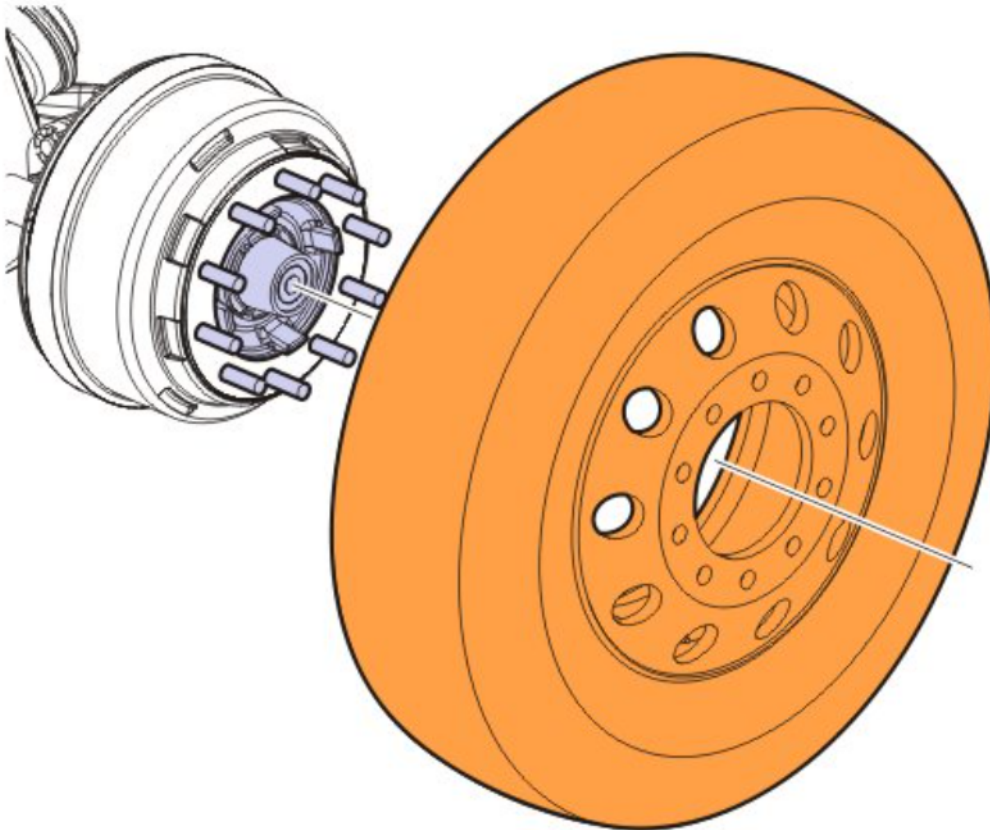

- . Install the wheel nuts.
- . Tighten the wheel nuts to 610 Nm (450 ft-lb).

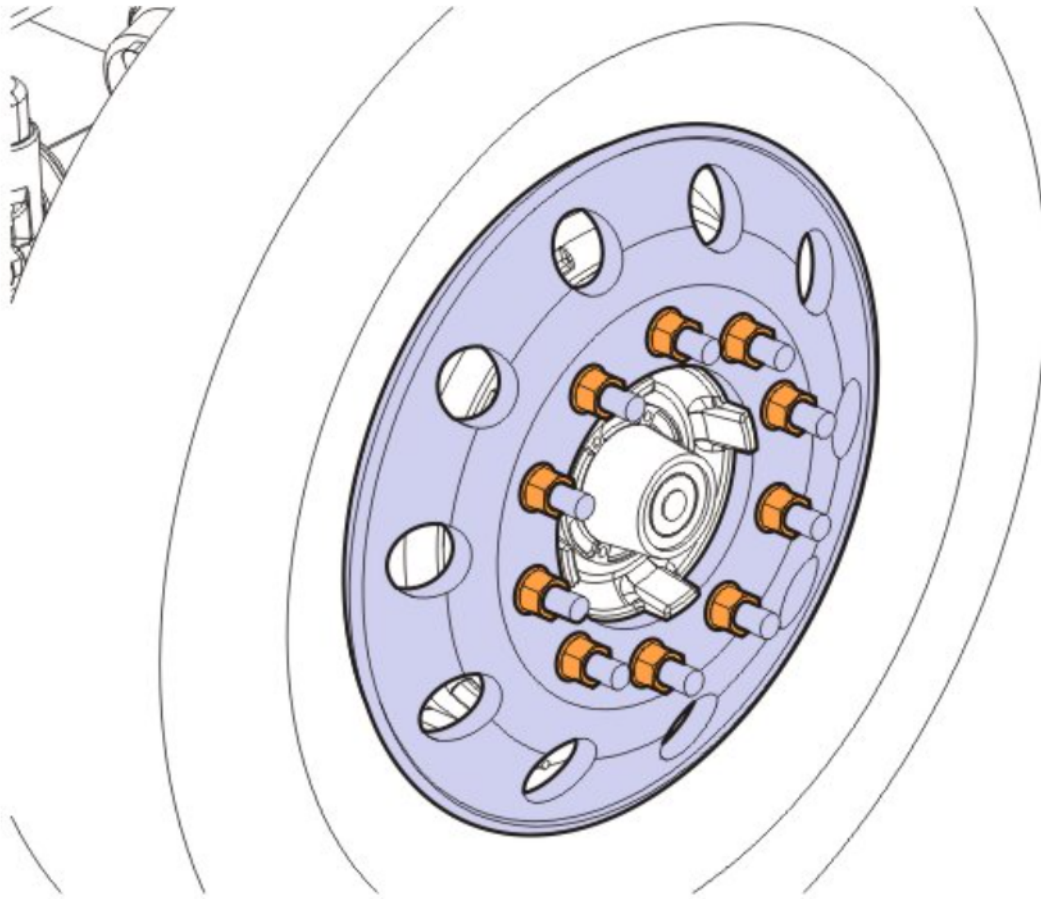

- Adjust the brake as recommended per (slack adjuster) manufacturer.

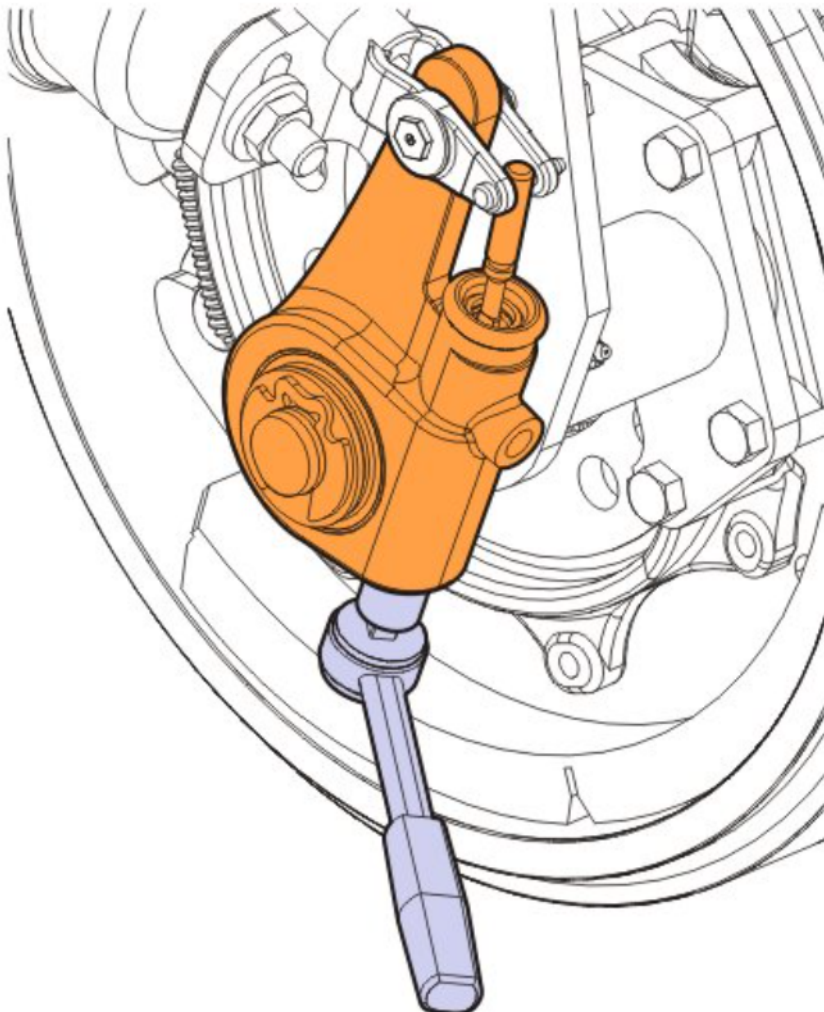

- . If applicable, install the slack adjuster pawl.

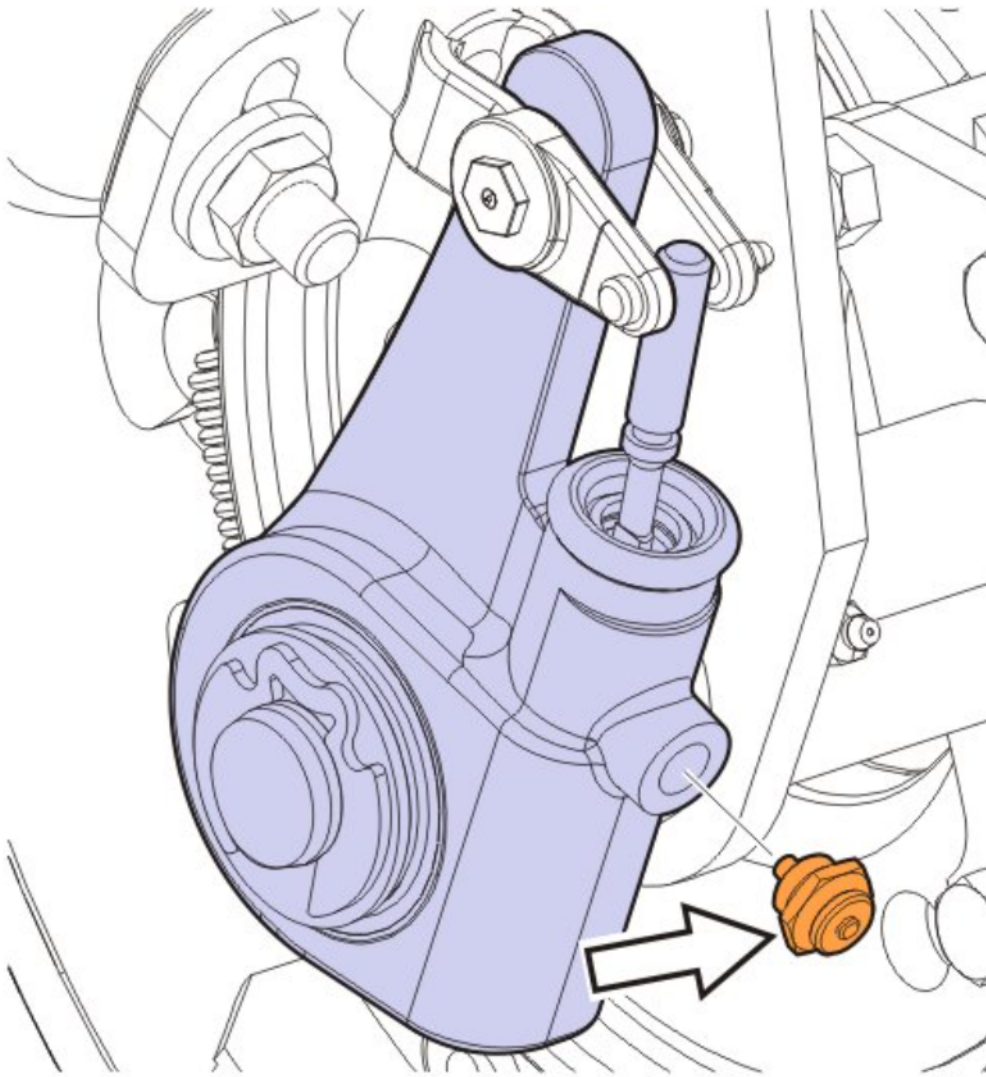

- . After brake the adjustment, rotate the wheel and ensure the brake is not dragging or the drum is not out of round.
- . Repeat steps 1 through 21 for the right side of the truck.
- . Lift the steer axle with a jack, remove the jack stands, and lower the axle.
- . Go to Commissioning the Truck for Operation.

## Commissioning the Truck for Operation

- . Connect the battery cable to the negative (ground) terminal.



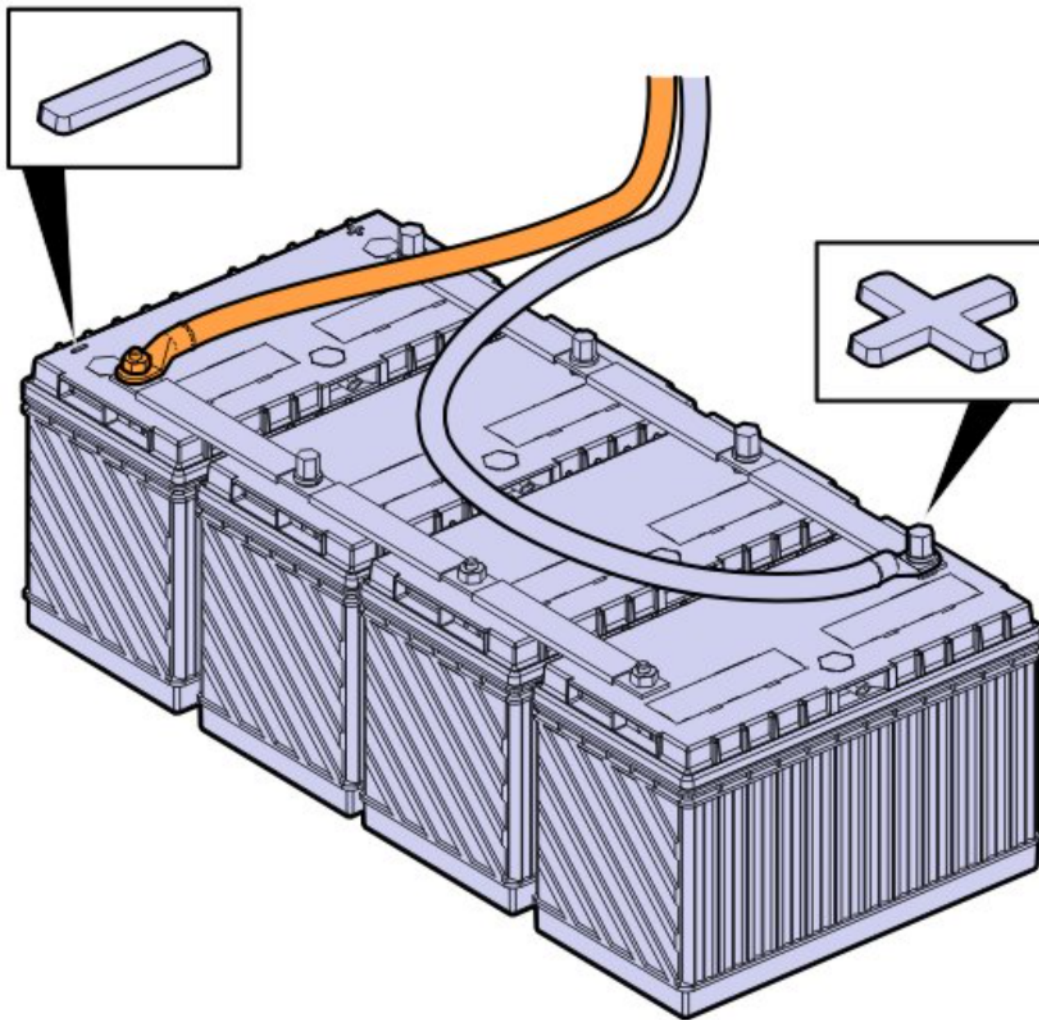

Remove the wheel chocks.

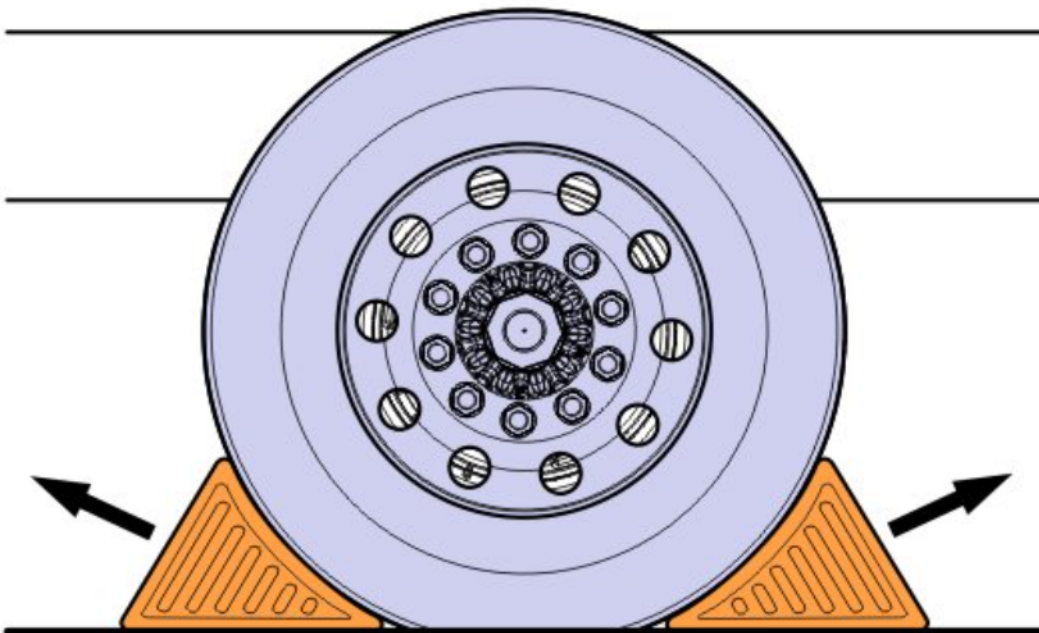

Reimbursement

<p><b>This repair may be eligible for reimbursement if a product failure was experienced within time and</b></p>	<p><b>UCHP Reimbursement</b></p>
------------------------------------------------------------------------------------------------------------------	----------------------------------

Copyright to this documentation belongs to the Volvo Group. No reproduction, copying, change, amendment or other similar disposal is entitled without prior written consent by the Volvo Group

The information contained herein is current at the time of its original distribution, but is subject to change. The reader is advised that printed copies are uncontrolled.

mileage limits of the applicable Warranty coverage. Reimbursement is obtained via the normal claim handling process.	
Claim Type (used only when uploading from the Dealer Bus. Sys.)	W
Labor Code	
Primary Labor Code (Brake S-Cam, Replacement)	5143-03-09-01 3.0 hrs.
Causal Part	85137267

VOLVO Trucks North America reserves the right to make any changes in design or to make additions to or upon its products without incurring any obligations to install the same on vehicles previously built.