

## 2.0 Rear Camera Mount - Convoy 1200A

**Date:** August 4, 2021  
**Bulletin Name:** FDM-SVC-005  
**Model:** Oshkosh S-Series  
**Units Affected:** 2.0 Front Discharge Mixers

### Purpose:

This bulletin provides instruction for installing a rear camera mount to hold a Convoy model 1200A rear camera.

### Notice:

- This bulletin should be read and understood in its entirety before performing this procedure.
- All procedures outlined in the bulletin must be performed by skilled service personnel. Refer to the product service manual for descriptions of maintenance procedures.

SAFETY NOTICE

Perform your company's Lockout/Tagout procedure. If your company does not have a Lockout/Tagout procedure, follow OSHA 1910.147 and 1910.146 Confined Space as appropriate.

SAFETY NOTICE

Use appropriate Personal Protective Equipment (PPE) as required by your company.

### Tools and Equipment Required:

Customer to supply:

- Hand tools
- Torque wrench - inch pounds

### Parts Required:

Item	Part Number	Description	Qty.
1	A000W006	BRKT, CAMERA, SVC	1

### Procedure:

#### ***Lockout/Tagout***

1. Place unit on a flat surface, engaged parking brake, chock truck tires, and perform your company's Lockout/Tagout procedure. If your company does not have a Lockout/Tagout procedure, follow OSHA 1910.147 and 1910.146 Confined Space as appropriate.
2. The vehicle's BATTERY DISCONNECT switch is located on the left-hand side of the battery box. Use the battery disconnect switch when performing any maintenance so the vehicle cannot accidentally be started.
  - a. Turn the battery disconnect switch (Figure A, Item 1) counterclockwise so the hole on the switch aligns with the hole in the bracket (Figure A, Item 2).
  - b. Install the safety lockout device ring (Figure B, Item 1) through the holes on the battery disconnect switch and the bracket.

c. Install a padlock (Figure B, Item 2) onto the safety lockout device ring, lock it, and put the key in your pocket. If more than one person is working on the vehicle, each person must install his or her own padlock.

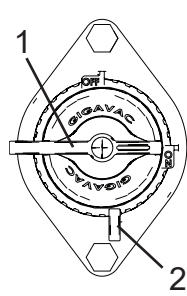

Figure A

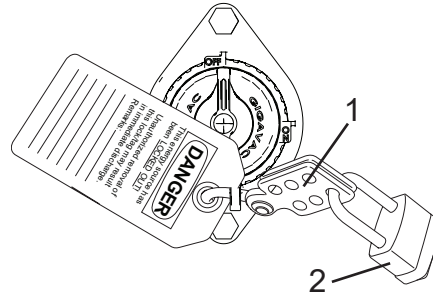

Figure B

### Installation

3. Disconnect the camera harness connector from the hood hatch harness.
4. Loosen and remove the screws, flat washers and lock nuts securing the camera and bracket to the hood hatch, see Figure 1. Remove the camera and bracket from the hood hatch, the camera and bracket will not be reused.

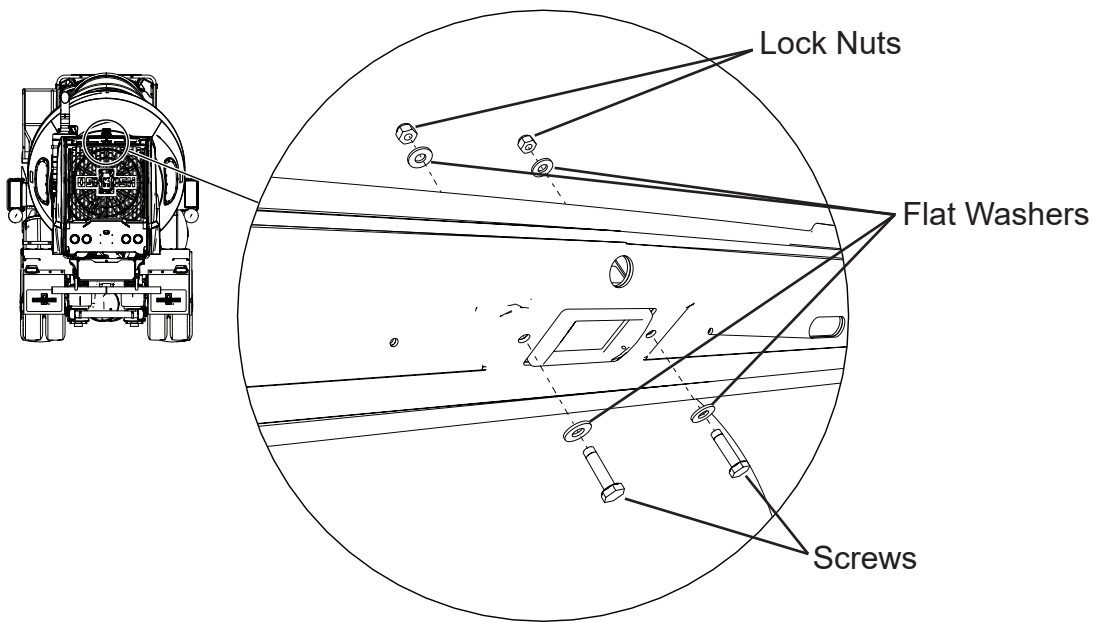

Figure 1

5. Secure a Convoy Model 1200A camera to mounting bracket (A000W006) with four hex screws with flat and lock washers supplied with the Convoy Model 1200A camera, see Figure 2.

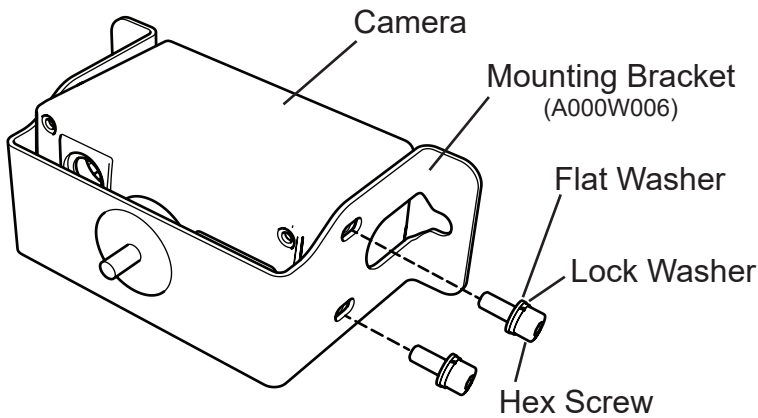

Figure 2

6. Mount the camera and bracket to the hood hatch with screws, flat washers and lock nuts removed in Step 4, see Figure 3. Final tighten mounting hardware to 65 in. lbs.

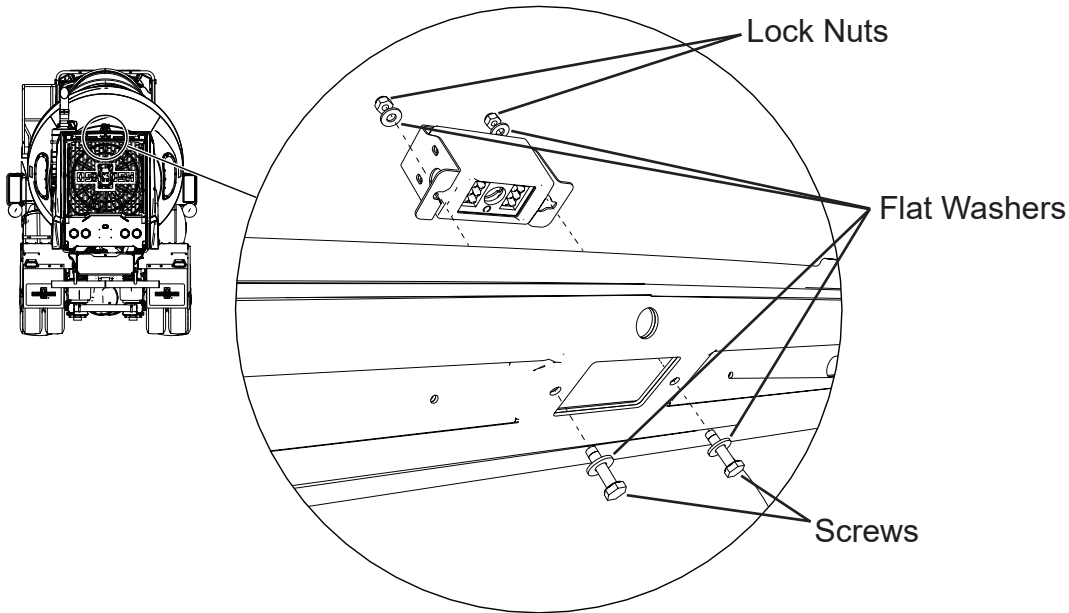

Figure 3

7. Connect camera harness connector to hatch harness connector.
8. Remove lockout/tagout and tire chocks.

### Continuous Improvement:

The change included in this document is part of the McNeilus Continuous Improvement Process.

*McNeilus's quality policy is providing customer satisfaction through innovative products, dedicated service, and a constant focus on continuous improvement.*



(888) 686-7278

[www.streetsmartparts.com](http://www.streetsmartparts.com)