



## Preliminary Information

### PIT5846 Interim Rear Toe Link Replacement

#### Models

Brand:	Model:	Model Years:	VIN:		Engine:	Transmissions:
			from	to		
Cadillac	SRX	2010 - 2016	All	All	All	All
Saab	9-4X	2010 - 2012	All	All	All	All

Involved Region or Country:	North America
Condition:	Warnings may include but are not limited to: <ul style="list-style-type: none"><li>• Service Traction Control message</li><li>• Service Stabilitrak message</li><li>• Stabilitrak malfunction indicator lamp (MIL) stays on or flashes intermittently</li><li>• Service Rear Axle message</li><li>• Chimes in combination with any of these messages or MILs</li><li>• Sway or wander while driving</li><li>• Loud metallic or other unusual noise from the rear suspension</li><li>• Off-center steering wheel</li></ul>
Cause:	Possible issue with the rear toe adjustment link(s)

#### Correction:

**IMPORTANT: If the vehicle is already at the dealership for service - follow the steps below**

**If the vehicle is not at the dealership and customer issue description includes the above listed conditions, the vehicle should be flat towed in for service.**

If diagnostics lead to an issue with the rear toe adjustment links perform the following:

**Note:** If the replacement of a rear suspension adjust link necessary, BOTH must be removed and DISCARDED and a 2 NEW rear suspension adjust links installed.

1. Remove the existing toe link and reserve for comparison.
2. Install new link.

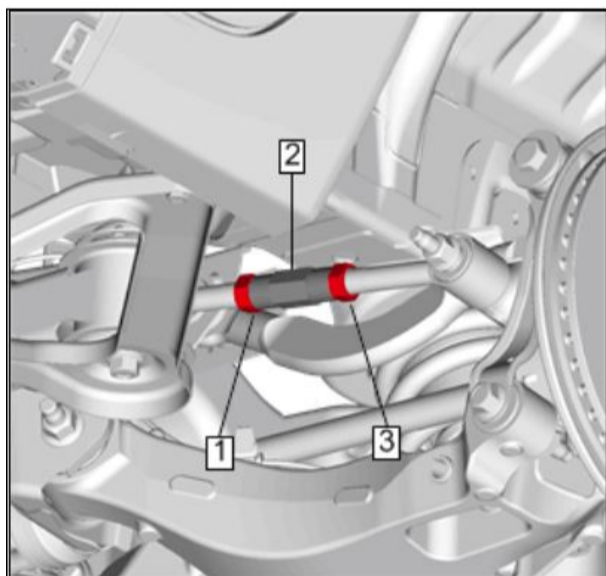

3. Loosen the rear suspension adjust link nuts (1) and (3).
4. Reference removed link. Adjust the toe by rotating the rear suspension adjust link (2) until the approximate length of old link has been reached. Finger tighten the adjust link nuts.
5. Repeat for opposite side.
6. Adjust the front and rear toe to specifications. When the final rear toe setting has been set, follow the tightening sequence below.

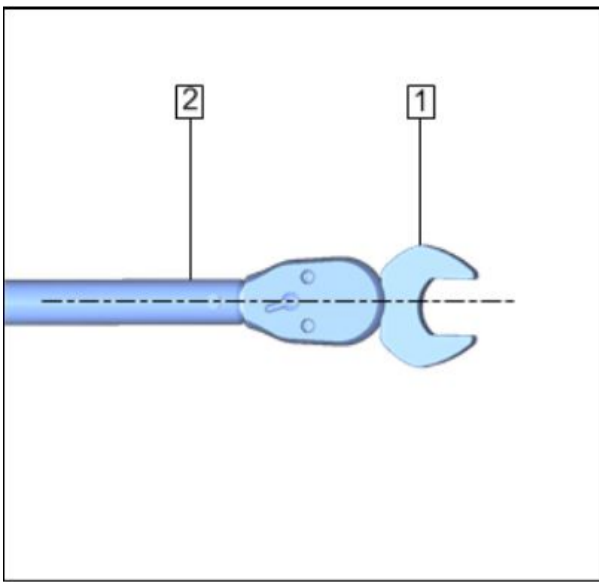

**Note:** The following steps use a 26 mm crow's foot wrench attached to a torque wrench. The orientation of the crow's foot to the torque wrench should be as close to in-line as possible to obtain accurate readings

7. Align the 26 mm crow's foot wrench (1) to the torque wrench (2) as illustrated above.

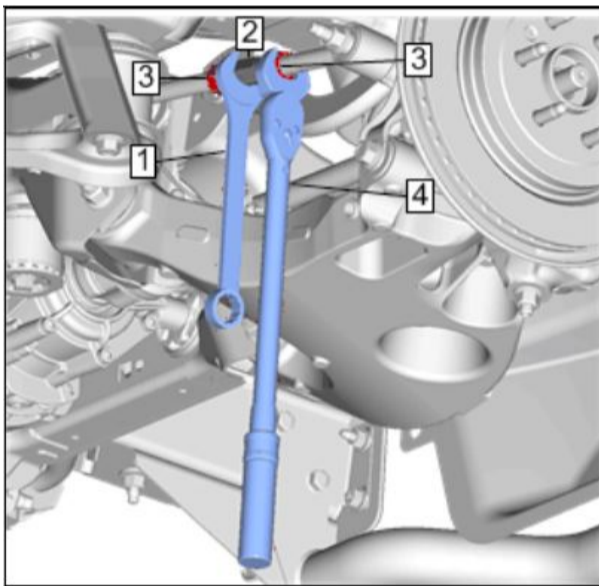

**Note:** Ensure the open end of the wrench (1) is on the adjust link (2) while the adjust link nuts (3) are checked with the torque wrench (4).

**Note:** It is critical to follow steps 7 and 8 precisely to avoid a repeat of this concern.

8. Using a backup wrench (1) to hold the rear suspension adjust link (2), tighten the rear suspension adjust link nuts (3) to 150 Nm (110 lb ft).

Parts Information

Description	Part Number	Quantity
Rear Suspension Adjustment Link	20867273	2

Part number 20867273 is on order writing control.

Dealers must place a CSO order and upgrade the CSO order to a SPAC case for the order to be fulfilled

Warranty Information

All vehicles repaired under the terms of this PI will be paid regardless of warranty status, age, or mileage by using the following labor operation. DO NOT charge customers for this repair.

Labor Operation:	Description:	Trans. Type	Labor Time:
9105595	Install Both Toe Rear Suspension Links (Includes Front and Rear Toe Alignment)	ZREG	1.9

Version History

<b>Version</b>	<b>1</b>
<b>Modified</b>	<b>07/01/2021 - Created on</b>



GENERAL MOTORS