



## Preliminary Information

### PIP5812A Diagnostic Tip: Potential For Oil/Moisture Condensate Freezing Up in Turbocharger Wastegate Regulator Solenoid Valve (TCV)

Proactive

Product Investigation Review Required

Models

Brand:	Model:	Model Years:	VIN:		Engine:	Transmissions:
			from	to		
Chevrolet	Cruze	2016 - 2019	All	All	1.4 LE2	All

<b>Involved Region or Country:</b>	<b>North America ,Argentina, Brazil, Colombia, Ecuador, Paraguay, Uruguay, Israel, Palestine, Middle East, Israel, Chile, Peru, China, Thailand, Australia, New Zealand, Egypt, Africa</b>
<b>Condition:</b>	<b>Possible DTC P0234 P0299 that can occur during cold weather driving.</b>
<b>Cause:</b>	<b>Oil/moisture condensate freezing up in Turbocharger Wastegate Regulator Solenoid Valve (TCV).</b>

### Correction

1. **Remove Turbocharger Wastegate Regulator Solenoid Valve**
2. **Drain Turbocharger Wastegate Regulator Solenoid Valve (TCV) by turning valve upside down.**
3. **Using clean shop air regulated to 15-20 PSI (103kPa), blow through all three ports (1, 2 &3) for 5 seconds each. Repeat twice.**

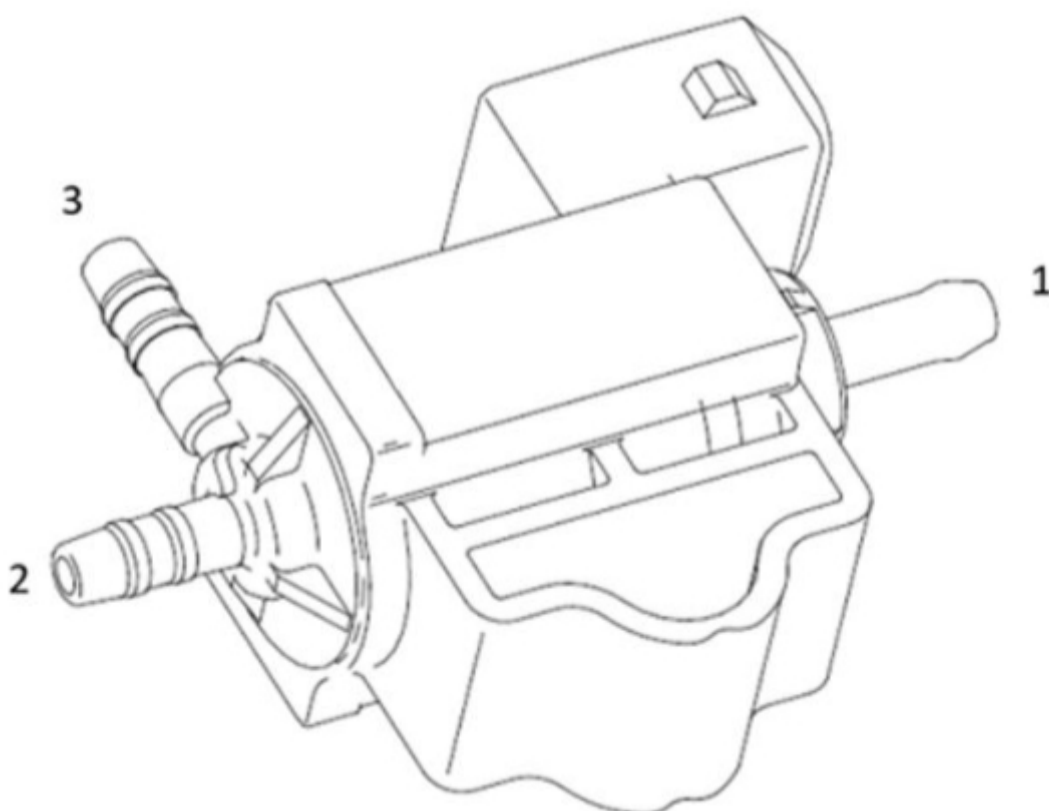

**Note: Check port #2 to assure the spring gets lifted off the seat. This will be determined by the compressed air not dead-heading when applied to port #2. When applying air**

to this port a small amount of air should be observed at port #3 and even less air will be noticed at port #1. If this does not happen, the TCV plunger may have hardened deposits from hot operating conditions which will impede TCV plunger movement and the Turbocharger Wastegate Regulator Solenoid Valve should be replaced.

**4. Reinstall Turbocharger Wastegate Solenoid Valve (TCV) using the latest service information and clear all DTC's using GDS and evaluate.**

### Warranty Information

For vehicles repaired under the Powertrain coverage, use the following labor operation. Reference the Applicable Warranties section of Investigate Vehicle History (IVH) for coverage information.

Labor Operation:	Description	Labor Time:
4023250	Turbocharger Wastegate Regulator Solenoid Valve Replacement	0.3 Hr.

### Version History

Version	2
Modified	06/25/2021 - Created on. 7/21/2021 - To remove Korea from Involved region or country due to no specific application



GENERAL MOTORS

© 2021 General Motors. All Rights Reserved.