



QUALITY ACTION

CAMPAIGN BULLETIN

Tow Hitch Receiver Installation Dealer Inventory

Reference: PC843
Date: September 17, 2021

Attention: Dealer Principal, Sales, Service & Parts Managers

Affected Models/Years:	Affected Population	Dealer Inventory:	SERVICE COMM Activation date:	Stop Sale In Effect:
MY2022 Frontier (D41) (Crew Cab Long Wheelbase - ONLY)	NA	50	September 11, 2021	YES

*******Dealer Announcement*******

Nissan is now escalating the temporary hold to a dealer inventory quality action to install a tow hitch receiver and trailer tow harness kit on **50** specific model year 2022 Frontier Crew Cab Long Wheelbase vehicles identified in Service Comm. Because of a supplier inventory issue, certain vehicles were manufactured and shipped without a tow hitch. Nissan is performing a quality action on these vehicles in order to comply with regulatory requirements. Nissan previously adjusted vehicle pricing for removal of the towing receiver hitch prior to shipment. Other MY22 Frontier units that received a credit for tow receiver hitch deletion that are not listed in Service Comm are not subject to Stop Sale and will require no additional action.

Affected vehicles are subject to stop sale and are either currently in dealer inventory or assigned and in transit to the dealer.

*******What Dealers Should Do*******

PLEASE FOLLOW THE ATTACHED INSTRUCTIONS:

1. Verify if vehicles are affected by this quality action using Service Comm or DBS National Service History - Open Campaigns I.D. **PC843**
 - New vehicles in dealer inventory can also be identified using DBS (Sales-> Vehicle Inventory, and filter by Open Campaign).
 - Refer to NPSB 15-460 for additional information
 - **Please continue to check newly arriving inventory for campaign applicability.**
2. Please **do not drive, loan, sell or trade** the specific vehicles in dealer inventory subject to this quality action.
3. Use the attached procedure to install tow hitch receiver and tow hitch harness kit on any vehicles affected by this quality action:
 - Nissan has developed an automatic parts shipment to provide affected dealers with the necessary parts to complete this quality action.
 - Parts will begin arriving at affected dealers **the first week of October 2021.**

4. The service department should use the claims coding in the attachment to submit a warranty claim for the installation labor (only) so the action can be closed on Service Comm and release the vehicle.
 - Dealers should add the towing receiver hitch as optional equipment priced at \$495 MSRP after the hitch and harness has been installed on the identified vehicles.

****** Dealer Responsibility ******

It is the dealer's responsibility to check Service Comm or DBS National Service History – Open Campaign using the appropriate campaign I.D for the inspection status on each affected vehicle currently in new vehicle inventory.

Thank you for your prompt attention to this matter.

NISSAN NORTH AMERICA, INC.



Aftersales DIVISION

******* Hitch Installation Instructions are included below, but can also be located on ASIST if needed *******

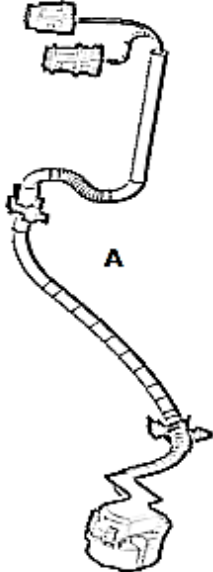
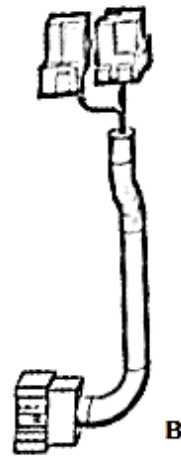
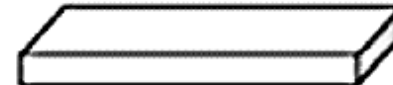

PC843 – 2022 FRONTIER CC LWB TRAILER TOW HARNESS AND TOW HITCH RECEIVER

INSTALL TRAILER TOW HARNESS:

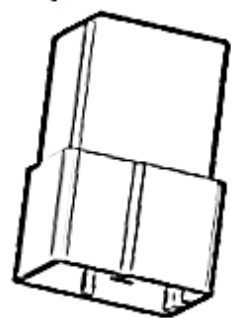
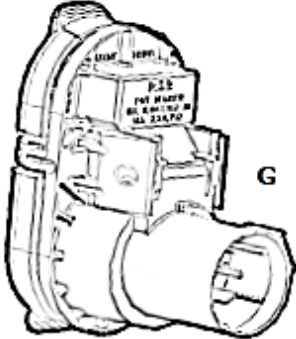
DESCRIPTION:	Trailer Tow Harness Kit (4/7)-PIN
APPLICATION:	Frontier
PART NUMBER(S) REQUIRED FOR INSTALLATION:	T99T8 9BU0A TOW HARNESS KIT (4/7-PIN)
KIT CONTENTS:	
      	
<div style="border: 1px solid black; padding: 5px;"> <p>STOP Important: Read Before Installation!</p> <p>Dealer Installation Recommended.</p> <p>▲ WARNING</p> <p>To avoid serious personal injury or property damage, obtain installation instructions before attempting to install this accessory. The installation instructions provide the necessary procedures for a safe installation.</p> <p>CUSTOMER INTERACT DOWNLOAD INSTRUCTIONS: Customers can obtain the above instructions for their Nissan or Nissan vehicle at www.infiniti-technic.com or www.nissan-technic.com respectively. From the home page, select Accessory Instructions, select your Model, Model Year, and Accessory Type or search for your Model, and/or Model Year, and/or Accessory Type including keyword or Part Number, then locate the instructions for your accessory.</p> <p>DEALER ASSIST DOWNLOAD INSTRUCTIONS: Dealer technicians can locate the installation instructions for this accessory by scrolling to and select, ACC, Install Instructions tab. Always download and use latest version of the installation instructions.</p> <p style="text-align: right;"><small>Installation Instructions Replacement Template 06932 00008 Rev: 07/2015</small></p> </div>	

**PART NUMBER(S)
REQUIRED FOR
INSTALLATION:**

KIT CONTENTS:

Item	Level	QTY	Description	Nissan Part Number
Kit	1	1	Trailer Tow Harness Kit (4/7-PIN)	T99T8 9BU0A
A	2	1	Exterior Harness Jumper	NA
B	2	1	Interior Harness Relay Jumper	NA
C	2	1	Urethane (foam) tape	999T8 BR100
D	2	2	185mm wiring cable tie strap	NA
E	2	1	Relay (brown colored)	25230 7996A
F	2	1	Relay (blue colored)	25230 79917
G	2	1	4/7-PIN Bumper connector with mounting clips	24340 EZ00B-C1
H	2	1	Installation Instructions Replacement Template	999V2 AW000
		NA	0 Installation Instructions (Nissan Website)	T99T8 9BU0A II

TOOLS REQUIRED:

- Screwdriver #2 Philips
- Trim Removal Tool, Nylon
- Rotary cutting (Dremel)-or-high speed right angle tool
- Cutting Disc's / Bit
- Work Light
- Pliers, Wire Cutting
- Safety goggles
- ~50mm = 2" Wide Shipping / Clear Packaging type tape
- Vinyl electrical tape
- Nissan Anti corrosion product:
 - Part # 999MP 9G001P Genuine Nissan Wax Sealer
 - Part # AP716-2100330 Genuine Nissan Mag 1 Anti-Rust 330

INSTALLATION CAUTIONS:



CAUTION

- Dealer installation recommended. Instructions may refer to Service Manual.
- Please read this instruction carefully before installing this product for correct installation.
- Please DO NOT use or install the part in ways other than what is described.
- Always use floor, seat and steering wheel protection.
- Parts utilizing adhesion as method of attachment are to be installed at surface temperature of 15-38° C
- Apply masking tape as needed to protect areas that may be scratched or damaged by tools.
- Always remove vehicle parts in the sequence directed. Improper procedure can damage parts.
- Take care not to scratch or damage any component during the removal or re-installation process.
- Trim pieces found to have witness marks or broken clips ARE NOT to be reinstalled.
- Store removed parts in a safe manner.
- If a problem occurs during installation, please contact Nissan dealer where product was purchased.

SECTION 1 - OVERVIEW

1.1) SYSTEM

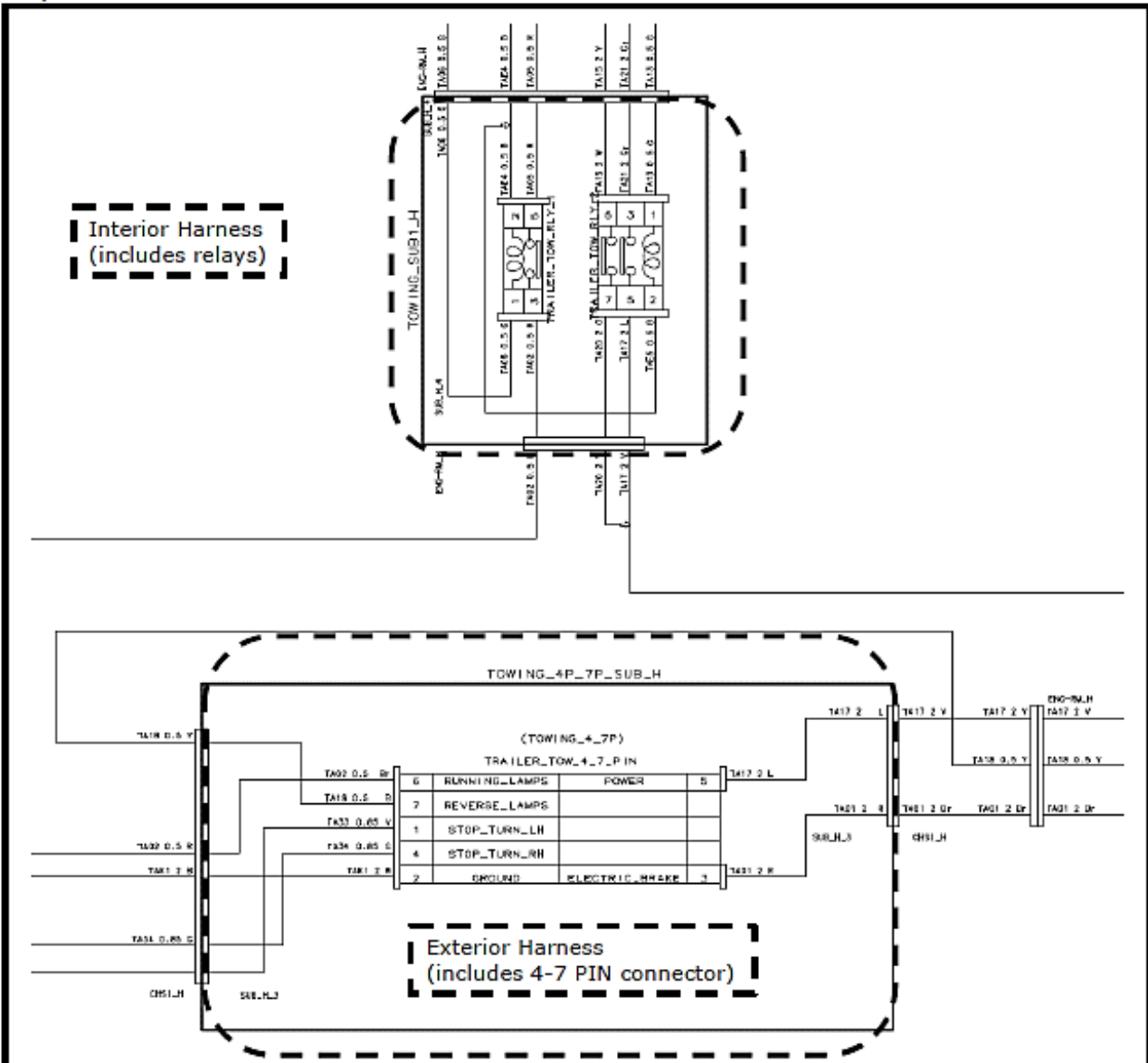

1.2) VEHICLE

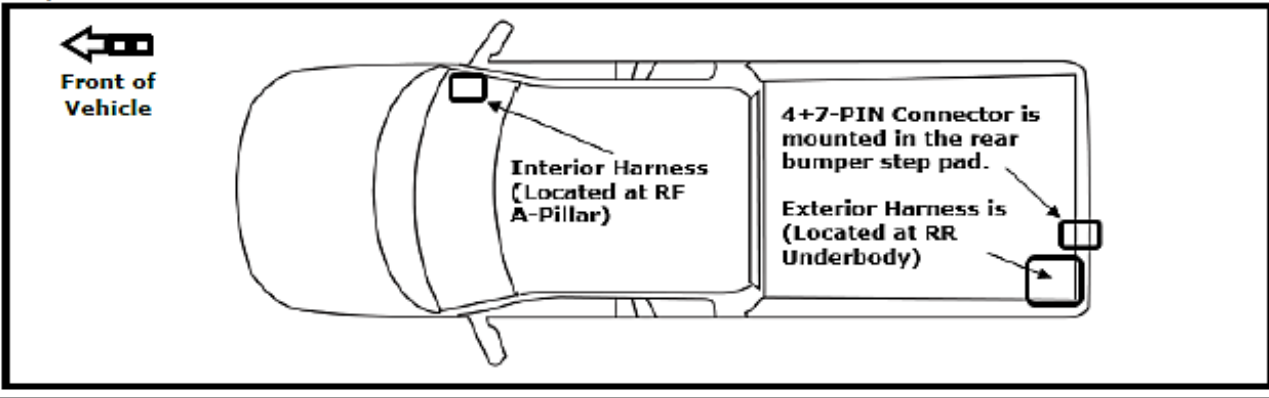

SECTION 2 - VEHICLE PREPARATION

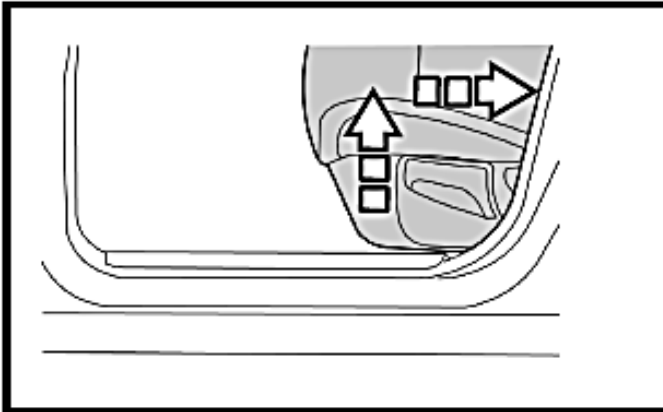

2.1) Move seats.

- a) Move both front seats to the full rearward position.
- b) Roll both front windows down.

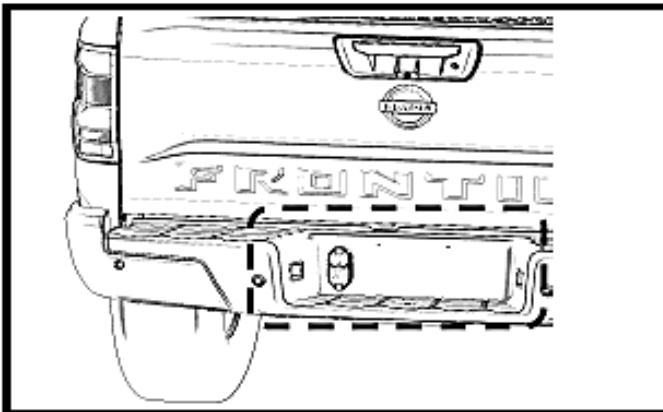

2.2) Prepare the vehicle for installation.

- a) Vehicle should be on a hoist to install the exterior harness and the rear bumper connector.
- b) Vehicle should be off the hoist to allow the RF door to fully open for access when installing the interior harness.

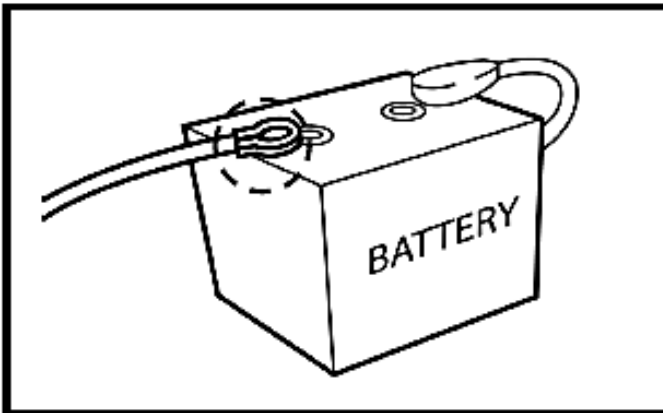

2.3) Disconnect battery terminal

- a) Locate negative battery terminal.
- b) Loosen nut with 10mm socket

Battery Terminal Nut



⚠ CAUTION

- Allow 3 min after key off with doors closed for vehicle power to time out.

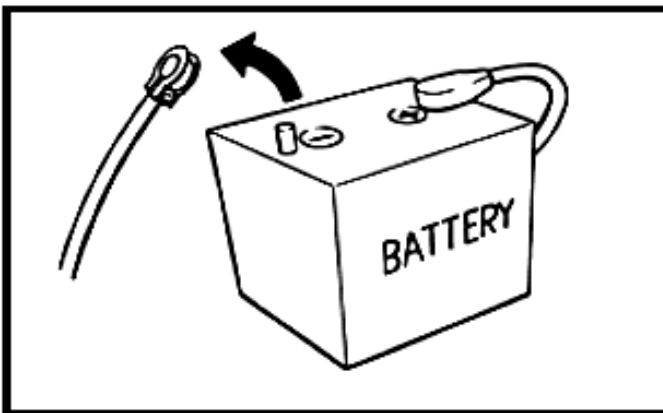

2.4) Disconnect battery terminal

- a) Lift negative battery terminal off stud.
- b) Isolate negative battery terminal.

⚠ CAUTION

- Allow 3 min after negative terminal disconnect before separating any electrical connectors.

SECTION 2 - VEHICLE PREPARATION



CAUTION

- Always confirm the ignition is in the "OFF" position before changing the E.S.S. position.
- If E.S.S. is not in Customer Mode, there will be a loss of normal vehicle operation, preventing accessory function check.

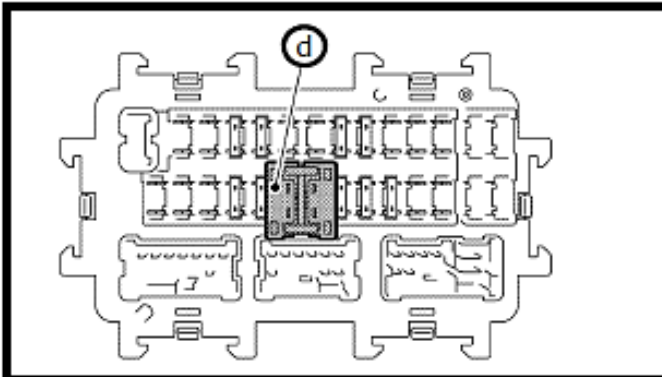

2.5) Check Extended Storage Switch Position

- a) Put shift lever in "P" position for A/T and CVT or "1st" for M/T .
- b) Apply park brake.
- c) Place ignition in "OFF" mode.
- d) Locate Extended Storage Switch in cabin fuse block as shown.
- e) Confirm Extended Storage Switch is in "Customer" (In/Engaged) position.
- f) If ESS is not In/Engaged, then proceed to step 2.2 .

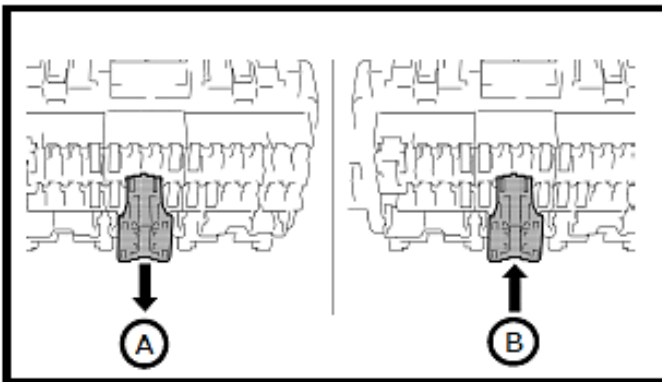

2.6) Changing ESS Position

- a) To disengage Customer Mode, pull out in **A** direction as shown.
- b) To engage Customer Mode, press in **B** direction as shown.

Condition	Switch Position	Note
Vehicle is delivered to the dealer	Transit (OUT)	
Vehicle is being stored at the dealer	Transit (OUT)	
Vehicle is delivered to customer	Customer (IN)	

2.7) Record Customer Presets

- a) Place ignition in "ON" mode.
- b) Record the customer radio presets and other presets as required.

Preset	1	2	3	4	5	6	7	8	9	10

- c) Place ignition in "OFF" mode.

SECTION 3 - INTERIOR HARNESS INSTALL PREPARATION

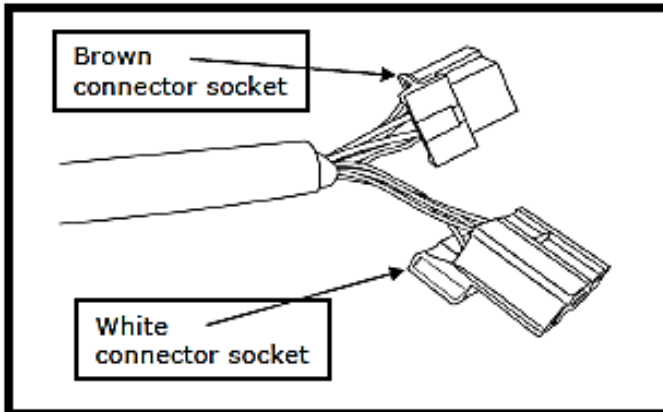

3.1) Prepare the Interior (Relay jumper) harness

- a) Locate the relay socket connectors
- b) The square Brown relay connector socket is for the brown relay.
- c) The rectangular White relay connector socket is for the blue relay.

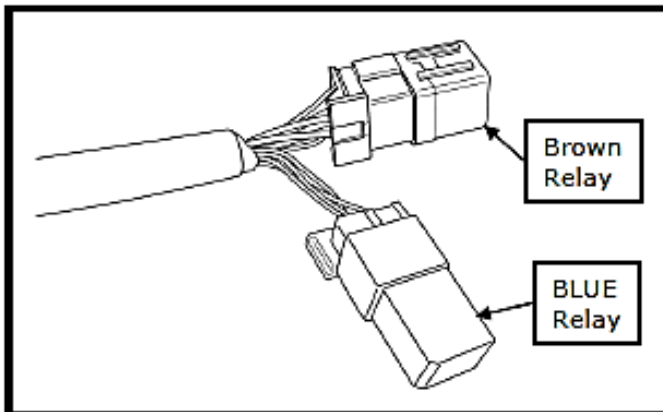

3.2) Install relays into their sockets

- a) Install the Brown relay into the brown square socket.
- b) Install the Blue relay into the white rectangular socket.

CAUTION

Be sure that the relays are fully seated into their respective sockets.

3.3) Wrap the relays with foam tape

- a) Align the relay sockets as shown.
- b) Peel the foam tape backing and place relays as shown onto the sticky side of foam tape.
- c) Tightly wrap remaining foam tape around the relays and pinch over the tops as shown below.

CAUTION

Position sockets backs together as shown and wrap all the foam tape tightly around the relays and sockets.

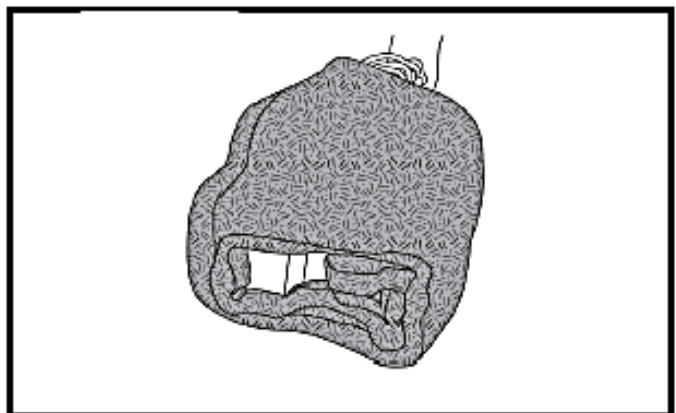
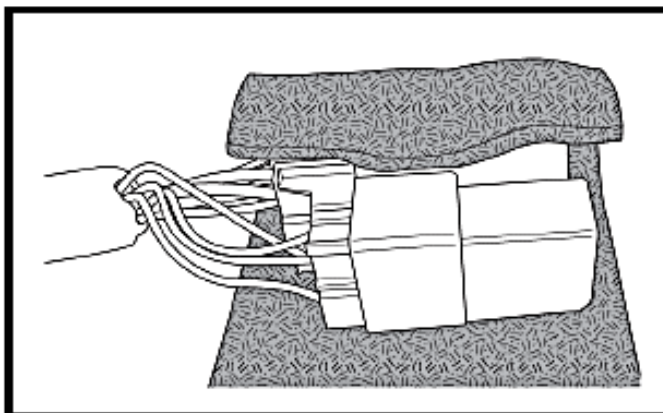
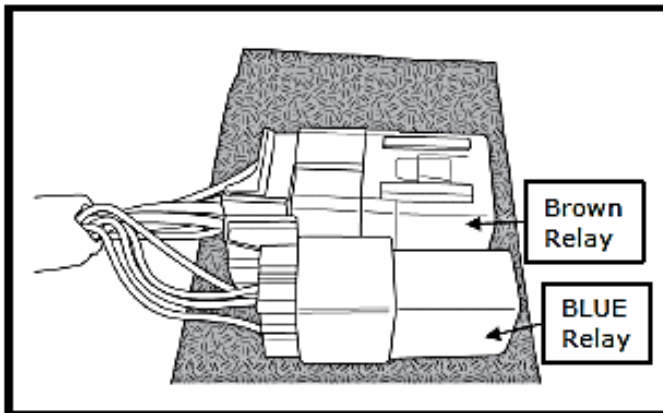

SECTION 3 - INTERIOR HARNESS INSTALL PREPARATION

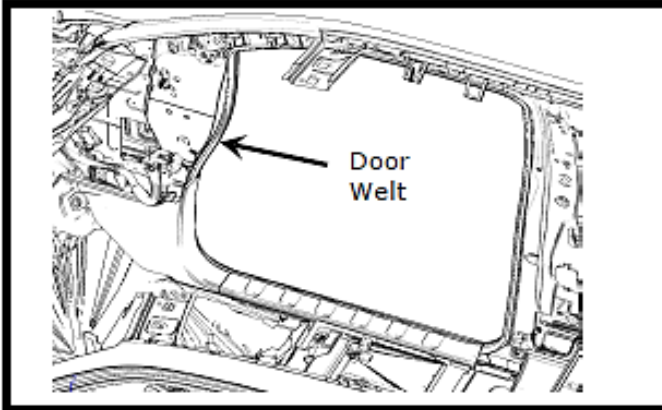

- 3.4) Locate the RF door and open for installation.
- a) The interior harness will be installed.
 - b) Do **not** remove any of the RF door welt for this installation.

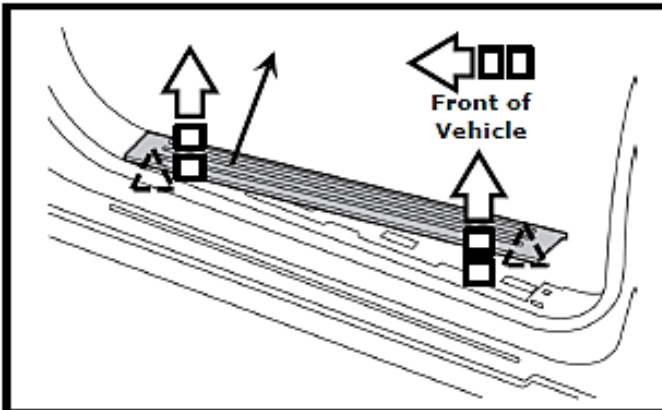

- 3.5) Locate and remove the RF door kick plate.
- a) Using trim removal tool at rearward end of inner kick plate, pry inner kick plate up to disengage the trim clips.
 - b) Using trim removal tool at forward end of inner kick plate, pry inner kick plate up to disengage clips.

Clip



- c) Store the inner kick plate in a safe place.

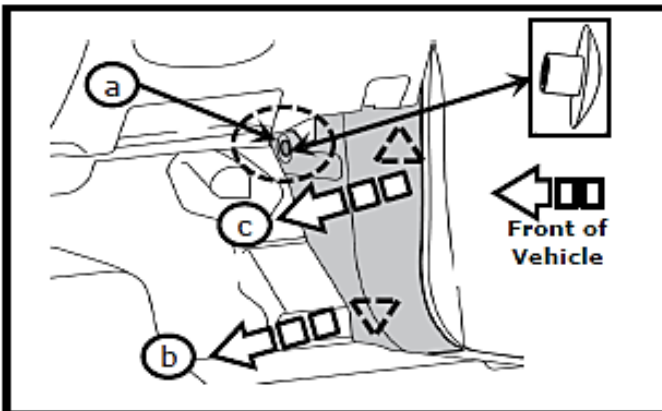

- 3.6) Locate the RF door inner dash side finisher

- a) Remove trim retaining fastener from lower kick trim with flat screwdriver

Trim Fasteners



- b) Disengage lower trim pawl by pulling toward interior as shown.

Upper Pawl



- c) Disengage upper trim pawl by pulling toward interior as shown.

Lower Pawl



SECTION 4 - INTERIOR HARNESS RELAY JUMPER - INSTALLATION PROCEDURE

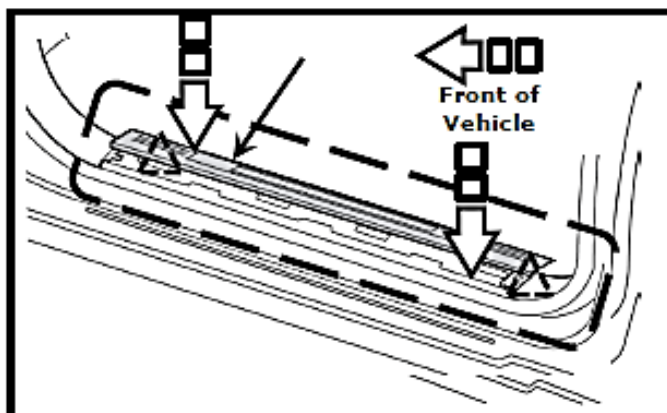
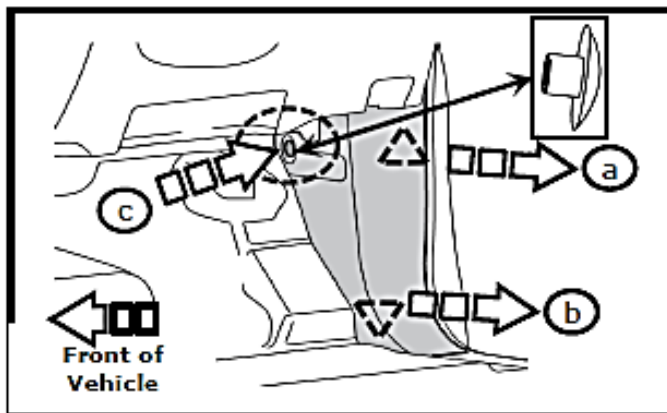
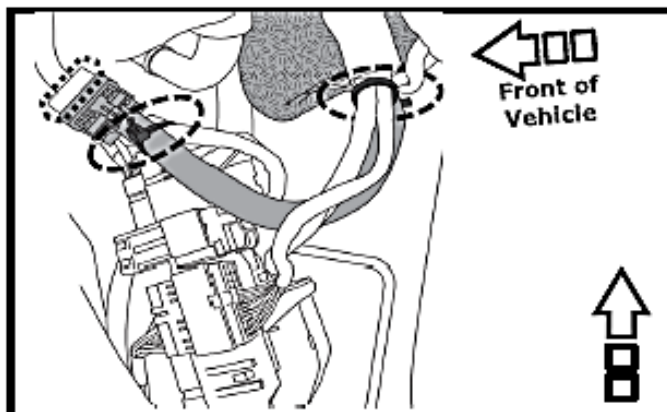
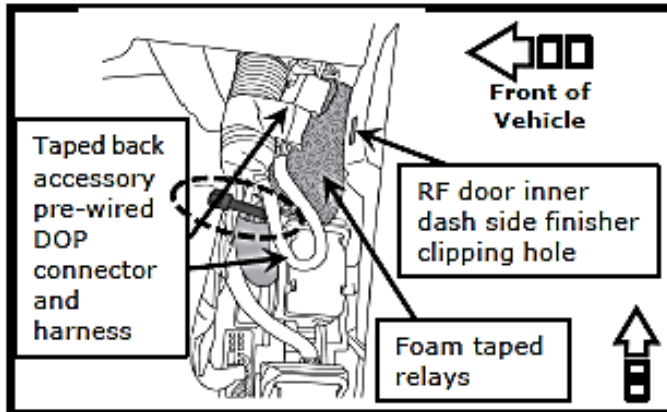

4.1) Install foam taped relays and route harness

- a) Install foam taped relays between the main harness and the inner sheet metal, routing the interior harness wiring down, behind and forward of main harness as shown.
- b) Route wire bundle forward and outboard of the Accessory pre-wired DOP connector as shown.
- c) Cable strap below the relays to main harness as shown.

CAUTION

- Be sure that relays are forward and clear of RF door inner dash side finisher clipping hole as shown.
- Do not cable strap around accessory pre-wired DOP connector or harness.

4.2) Connect and finish interior harness routing

- a) Locate the 12-PIN prewire connector taped back onto the interior section of the engine harness and release for use. It is located near to the inline connector bracket. The prewired connector is taped back. Break the tear tape to gain access to the connector.

10-PIN Prewire Connector



- b) Insert the 12-PIN vehicle side prewire connector into the interior harness mating the 12-PIN connectors.
- c) Route interior harness along the existing vehicle engine harness and cable tie strap it with one strap on the relays and one in the center of the jumper.

4.3) Reinstall the RF door inner dash side finisher

- a) Engage upper trim pawl by pushing outward.
- b) Engage lower trim pawl by pushing outward.
- c) Install trim retaining fastener to lower kick panel trim by hand.

Pawls: Upper  **Lower** 

CAUTION

Be sure that RF door inner dash side finisher stays fully positioned and not opened at the top.

4.4) Reinstall Kick Plate - RH

- a) Starting at forward end, press down to engage all lower clips.
- b) Lastly, press down to fully engage all clips into floor metal and side trim pieces.

SECTION 5 - 4/7-PIN CONNECTOR INSTALL OVERVIEW

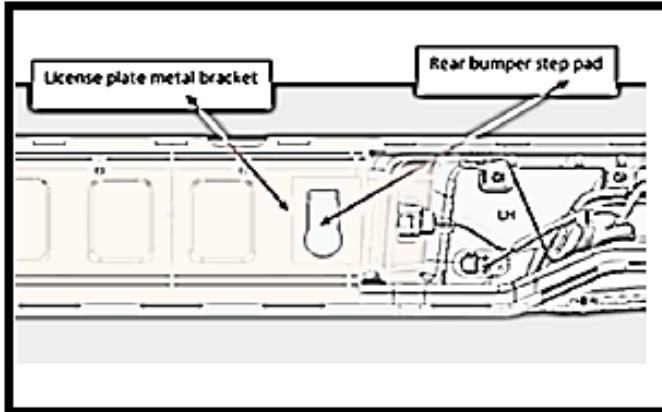

5.1) Target underbody view of license plate bracket.

- a) Locate the metal license plate bracket behind the rear bumper step pad.



CAUTION

- The rear bumper connector is installed without the need for removing the plastic bumper step pad from the vehicle.
- Do not scratch the bumper pad around the cutout throughout this installation.

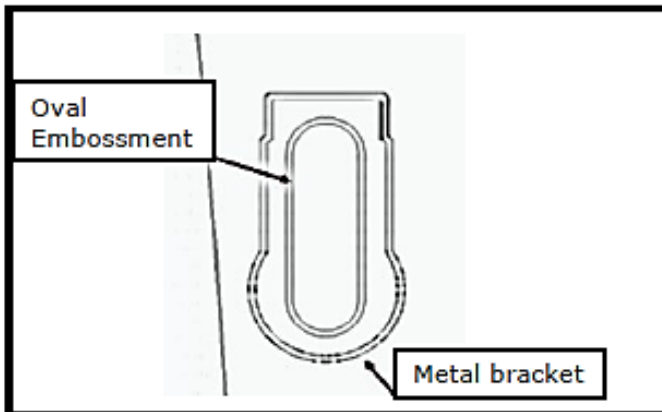

5.2) Metal cutout in relation to embossed oval

- a) Viewed from the rear of the bumper the object is to cut the bumper pad out to match the metal rear license plate bracket.
- b) The paper template cut out is located on the last full page. Print it out as actual size for correct scaling as shown below:

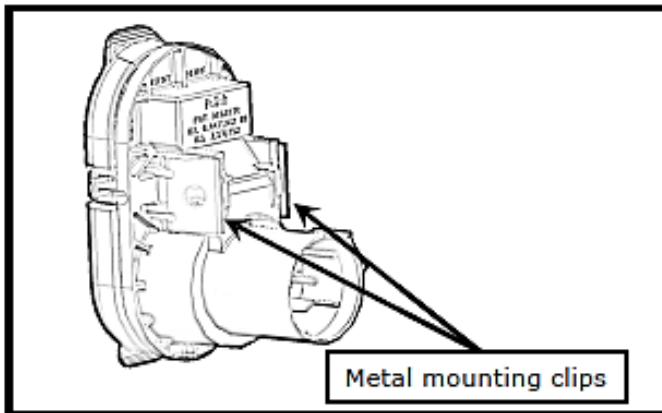

5.3) Bumper connector with mounting clips

- a) The provided 4/7-PIN bumper connector with mounting clips will install into the bumper step pad once the hole is cutout.
- b) The metal connector mounting clips will snap and fit onto the metal license plate bracket when the connector is installed.



CAUTION

Once installed if the connector needs to be removed squeeze the metal clips to release them from the rear metal license plate bracket.

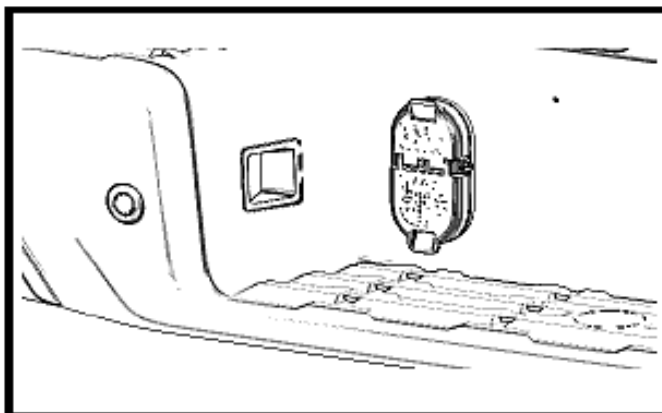

5.4) 4/7-PIN bumper connector

- a) The bumper connector installs into the rear bumper cutout as shown.



CAUTION

A proper Nissan anti-corrosion product must be used to prevent rusting and/or corroding on the complete cut edge.

SECTION 6 - PREPARATION - CUTTING THE REAR BUMPER STEP PAD

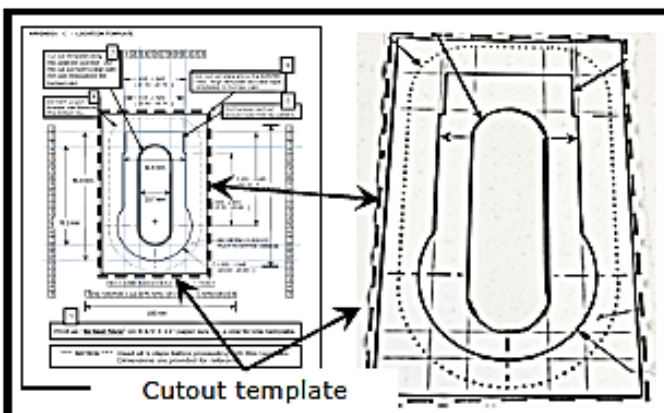
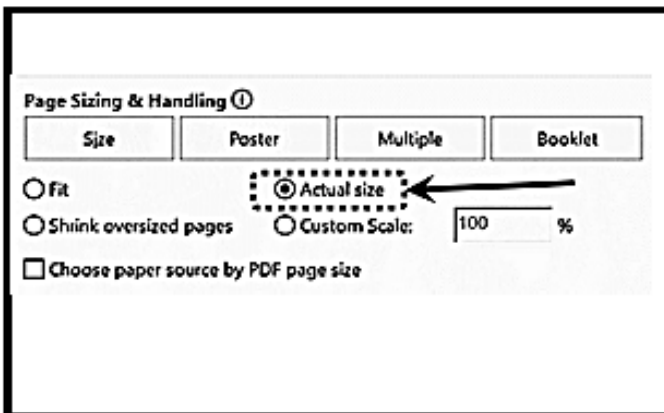
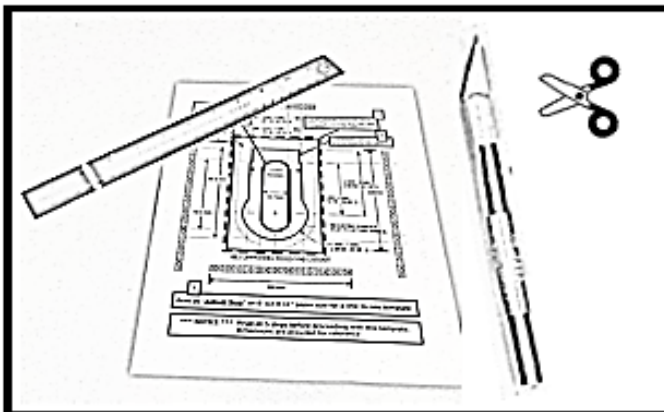
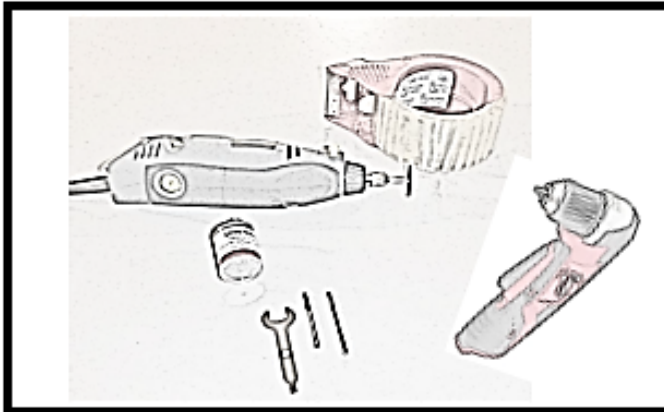

- 6.1) Gather supplies and tools required.
- a) Use of 2" wide clear shipping tape is preferred to tape the cut out template to the rear bumper step pad.
 - b) Use of a rotary cutting tool is used for cutting the hole into the rear bumper step pad. Dremel manufactures a rotary tool such as this.
 - c) Rotary tool cutting disk and bits as shown are recommended for cutting out the necessary hole into the rear bumper step pad.
 - d) Obtain a straight edge (ruler), X-Acto knife (utility knife, precision knife or hobby knife) to cut out the inside and scissors to cut the outside of template.

NOTICE

- These instructions are for using the template and cutting from the rear of the bumper pad.
- Alternately a high speed right angle drill with the cutting bit can be used to cut the rear bumper step pad by tracing the metal key hole in the metal license plate bracket.

- 6.2) Obtain cutout template for cutting the step pad
- a) Print the Location Template that is located in Appendix B as actual size.

CAUTION

- Print as "Actual Size" on 8 1/2 X 11" paper size for a one-to-one template.
- Read all 5 steps before proceeding with this template.
- Dimensions are provided as reference.

- b) This template is used to cut the bumper step pad out from the rear side of the bumper.
- c) Template sequence of steps that are included on the template and maintain a copy as an installation reference.

SECTION 6 - PREPARATION - CUTTING THE REAR BUMPER STEP PAD

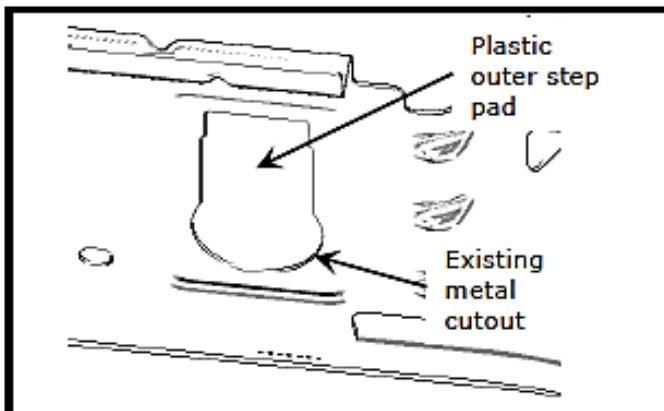
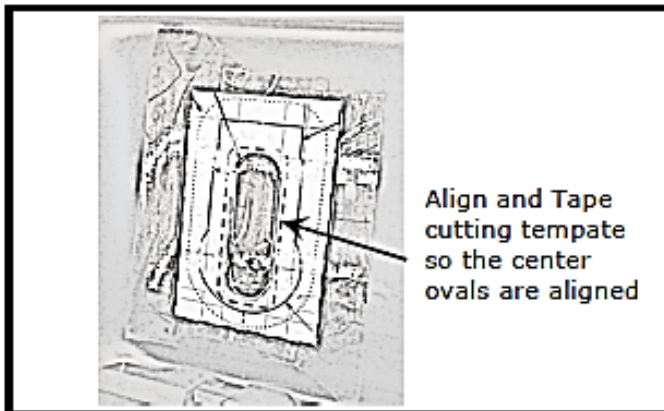
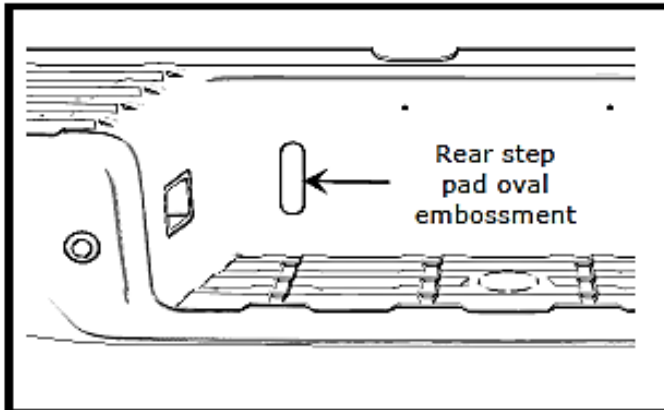
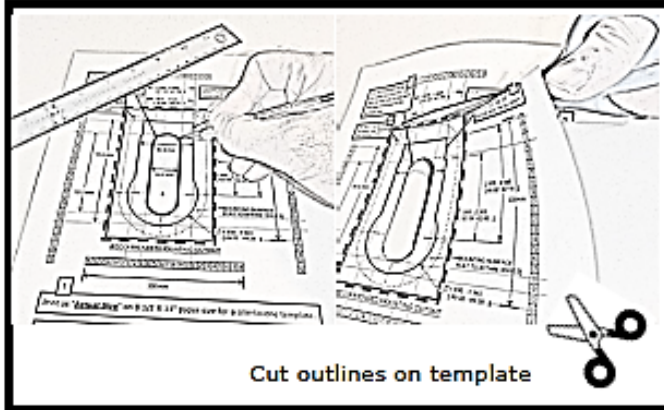

6.3) Cut out the template.

- a) Cut out the template as described using the straight edge (ruler), X-Acto knife (utility knife, precision knife or hobby knife) to cut out the inside and scissors to cut the outside of template.



CAUTION

Follow the instructional sequence of steps that are written on your reference template during this cutting process.

6.4) Locate the 4/7-PIN Bumper connector install location on the rear bumper

- a) Locate oval embossment on rear side of the rear bumper step pad to the left of the rear license plate.
- b) If necessary remove the license plate for cutting access.



CAUTION

Follow the numbered sequence of steps that are included on your reference template during this cutting process.

6.5) Install the prepared cutting template onto the rear bumper step pad.

- a) Align oval in the cutout template with the oval embossment on the rear bumper pad.
- b) Use a few strips of clear packaging tape to tape over the whole template onto the bumper pad.



CAUTION

A few strips of two inch wide clear packaging tape allows you to fully apply the template to the rear bumper step pad, and serves to protect it from scratches during cutting.

6.6) Underbody rear facing view of steel license plate bracket where the tow connector mounts into.

- a) Notice view of step pad through the steel license plate with tow connector cutout.



CAUTION

- When cutting the rear bumper pad be sure to not scratch this metal license plate bracket cutout edge.
- If the bracket cutout gets scratched cover the damaged area with the proper Nissan anti-corrosion product to prevent rusting.

SECTION 7 - EXTERIOR HARNESS - CUT THE REAR BUMPER STEP PAD



7.1) Cut out the rear bumper step pad.

- a) Using the rotary (Dremel) cutting tool, with the cutting disc cut out bumper step pad and using straight line cuts as close to the template cutout dashed line.

CAUTION

- Wear safety goggles to protect your eyes.
- Be sure not to go out of the bounds indicated on the template.
- Be careful not to scratch the bumper pad with cutting tool.

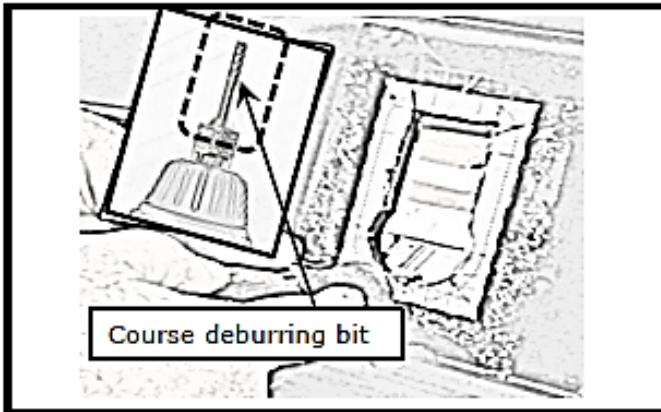

7.2) Cut out the rear bumper step pad (continued)

- a) Using the rotary (Dremel) cutting tool, with a course deburring cutting bit cut out the remaining bumper step pad up to the template cutout dashed line.

CAUTION

- Wear safety goggles to protect your eyes.
- Be sure not to go out of the bounds indicated on the template.
- Be careful not to scratch the bumper pad with cutting tool.

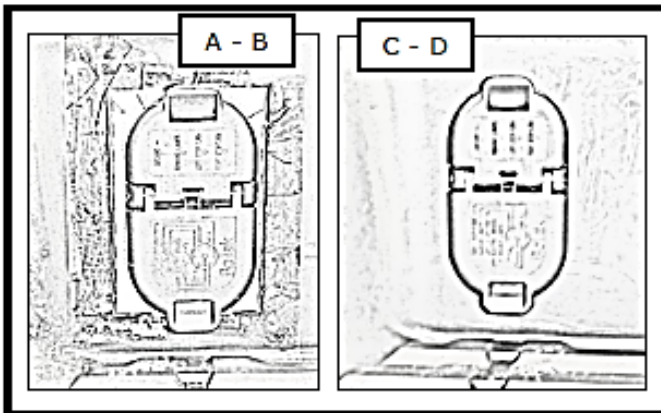

7.3) Trim cut out for connector fitment

- a) Using the 4/7-PIN bumper connector check the cutout for fit.
- b) Continue to trim the cutout with the deburr bit until the 4/7-PIN bumper connector can be push through the bumper step pad.
- c) Once the connector can clear the bumper step pad, remove the paper template and deburr and clean the sight.
- d) Insert the 4/7-PIN bumper connector pushing it until you hear the metal clips engage into the rear metal license plate bracket.

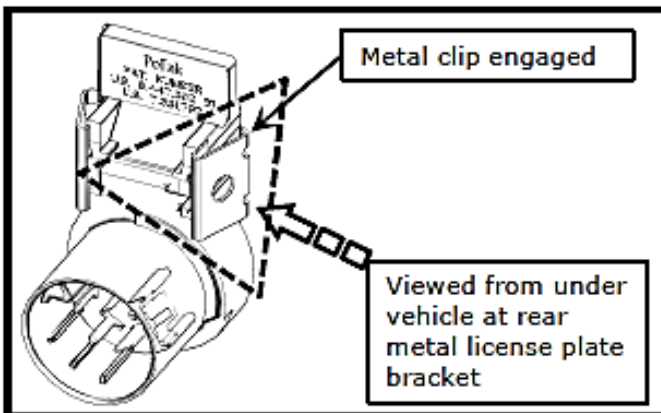

7.4) Fully seat the 4/7-PIN bumper connector

- a) Visually check that the 4/7-PIN bumper connector metal clips are fully engaged onto the rear metal license plate bracket.

CAUTION

- Check from under the vehicle that the metal clips on the 4/7-PIN bumper connector are fully engaged into the rear metal license plate bracket as shown.
- If the connector needs to be removed squeeze the metal clips to release them from the rear metal license plate bracket.

SECTION 8 - EXTERIOR HARNESS - INSTALLATION PROCEDURE

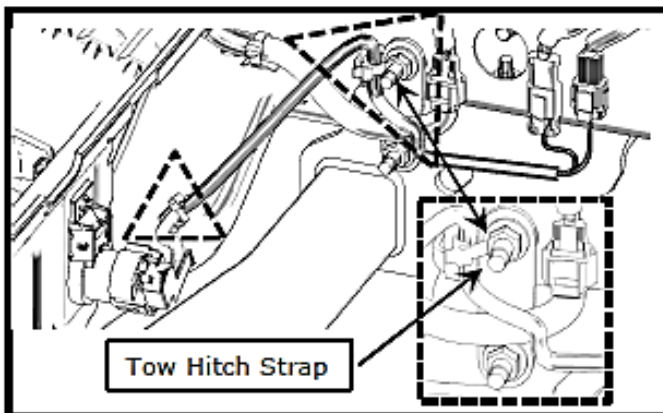
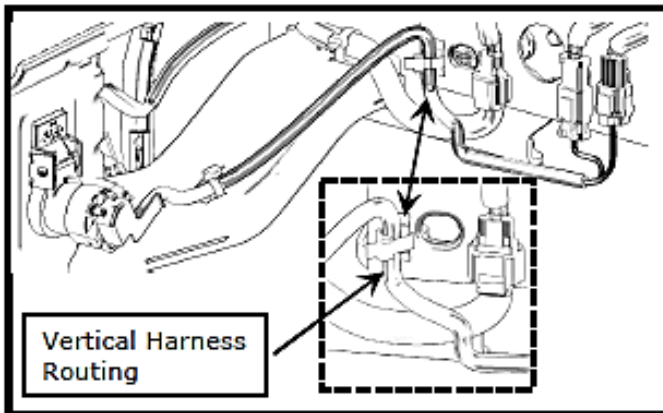
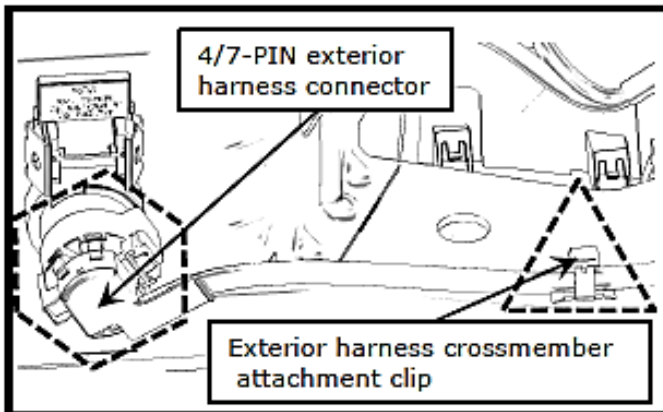
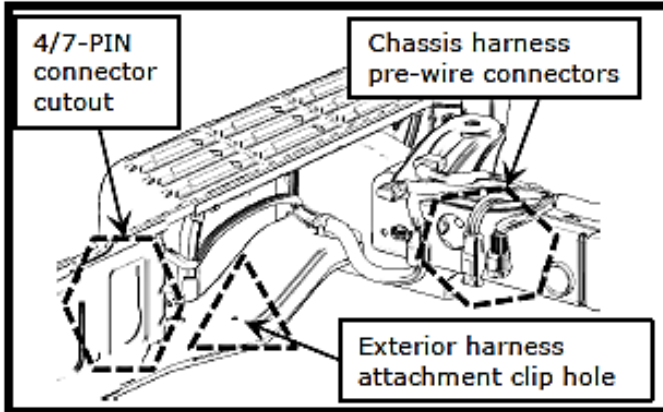

8.1) Overview

- a) Raise vehicle on a hoist to install the exterior harness to the vehicle.
- b) Locate 4/7-PIN connector already installed into the rear license plate bracket 4/7-PIN connector cutout.
- c) Locate 4/7-PIN exterior harness clip mounting hole in the top of the cross member as shown.
- d) Locate the two capped with dummy plugs chassis harness pre-wired connectors as shown.

8.2) Install 4/7-PIN exterior harness connector

- a) Install the 4/7-PIN exterior harness connector into the 4/7-PIN bumper connector as shown.

CAUTION

When mating *all* connectors make sure they're fully seated. Perform installation with a physical push-audible click-pull process.

- b) Route exterior harness and install the first harness attachment clip into the provided hole in the top of the rear cross member.

8.3) Install exterior harness to inline connectors

- a) Remove the two dummy plugs from the inlines shown on the chassis harness side (already in the truck). Using a screw-driver, push the tab in and slide the plug out.
- b) Route the exterior harness around the chassis harness and attach the two inline connectors (make sure the connectors are fully inserted and secured) and routed as shown.

8.4) Finish Exterior harness installation

- a) Attach the second harness clip into the rear frame rail rotating the harness CW to gain access to the frame hole as shown.
- b) Position exterior harness vertically to clear the tow hitch straps as shown.

CAUTION

Rotate exterior harness CW as necessary to allow the second harness clip to clear the tow hitch strap and fully seat into the frame hole.

SECTION 9 - FINISHING THE INSTALLATION

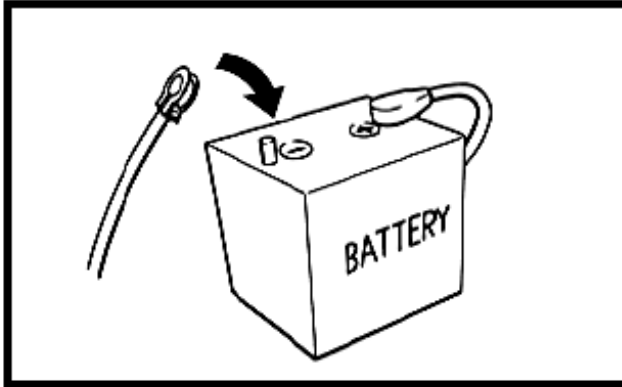

- 9.1) Reconnect the 12V battery
- Re-connect negative battery cable.
 - Tighten Negative battery terminal nut to 8 N·m (+/- 1) [71 in·lbs (+/- 9)]



CAUTION

Check that customer's radio settings are still active. If not restore the recorded customer presets from step 2.3 b

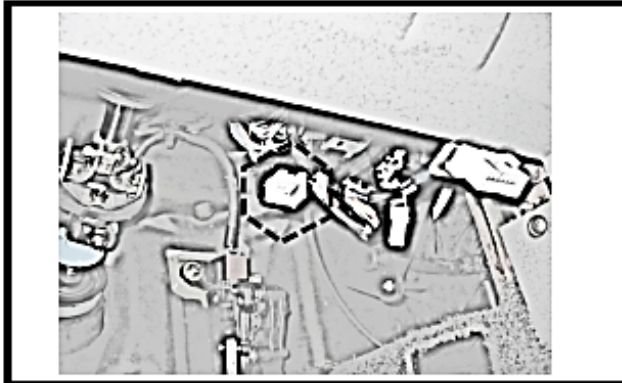

- 9.2) Trailer Brake Electrical Connector Location
- The pre-wire connector for adding a trailer brake controller unit with jumper is located in the left lower steering column area, near the diagnostic connector. This branch is taped back, break the tape to access the connector.
 - For trailer brake function, install trailer brake controller using controller manufactures instructions and the adapter harness specified in the application notes. Plug the adapter harness to the vehicle connector shown in the photo.

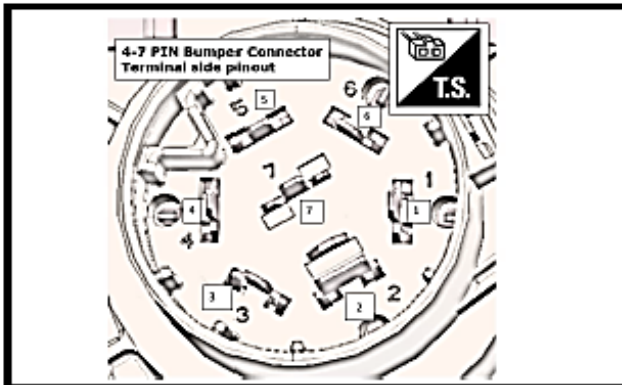

- 9.3) Electrical function check
- Visual check vehicle lighting functions for brake lights, turn, tail and backup. Test light, check power to trailer connector for brake light, turn signal lights and tail lights, and to trailer brake circuits if trailer brake controller was installed.
 - The 7-PIN connector terminal view is provided and the circuits are also identified below. The 4-PIN connector is internally wired inside the 4/7-PIN connector so it does not need to be checked.

Frontier 7-PIN Connector:

- Pin-1 = TA33 = Stop_Turn-LH
- Pin-2 = TAE3 = Ground
- Pin-3 = TA01 = Brake
- Pin-4 = TA34 = Stop_Turn-RH
- Pin-5 = TA17 = 12V (30A)
- Pin-6 = TA02 = Running_Lamps
- Pin-7 = TA18 = Reverse

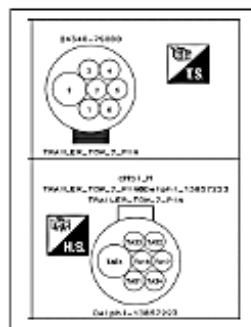

TRAILER_TOW_7_PIN					
TA02 D.S.B	6	RUNNING_LAMPS	POWER	5	TA17 2 W/A
TA33 D.75 LG/B	1	STOP_TURN-LH	REVERSE	7	TA18 D.S Y/B
TA34 D.75 Y/B	4	STOP_TURN-RH			
TAE3 2 B	2	GROUND	BRAKE	3	TA01 2 BR/W

 **CAUTION**

Take care not to scratch or damage any component during the removal or re-installation process. Trim pieces found to have witness marks or broken clips should be replaced with new parts.

10.1) Complete checklist:

- Tighten Negative battery terminal nut to 5.0 N.m (0.51 kg-m, 44 in-lb)
- Verify re-installed trim parts for proper fit (no gap, waviness, etc.), particularly the door sill weather
- Verify all windows and sunroof (if equipped), one touch operation and perform the reset procedure if necessary. Refer to the vehicle Service Manual for more details.
- Verify customers radio presets and other vehicle settings are all set as when initially received.
- If this vehicle will be returned to a dealer lot or showroom for an extended period of time, be sure the Extended Storage Switch is placed in the Transit position. See step 2.5
- Remove all tools, templates, and other debris from interior and bed of vehicle.
- Verify vehicle headliner, seat, steering wheel, center console, carpet, etc. are not soiled.
- Verify interior and exterior are not damaged.

APPENDIX B - MECHANIZATION DRAWING

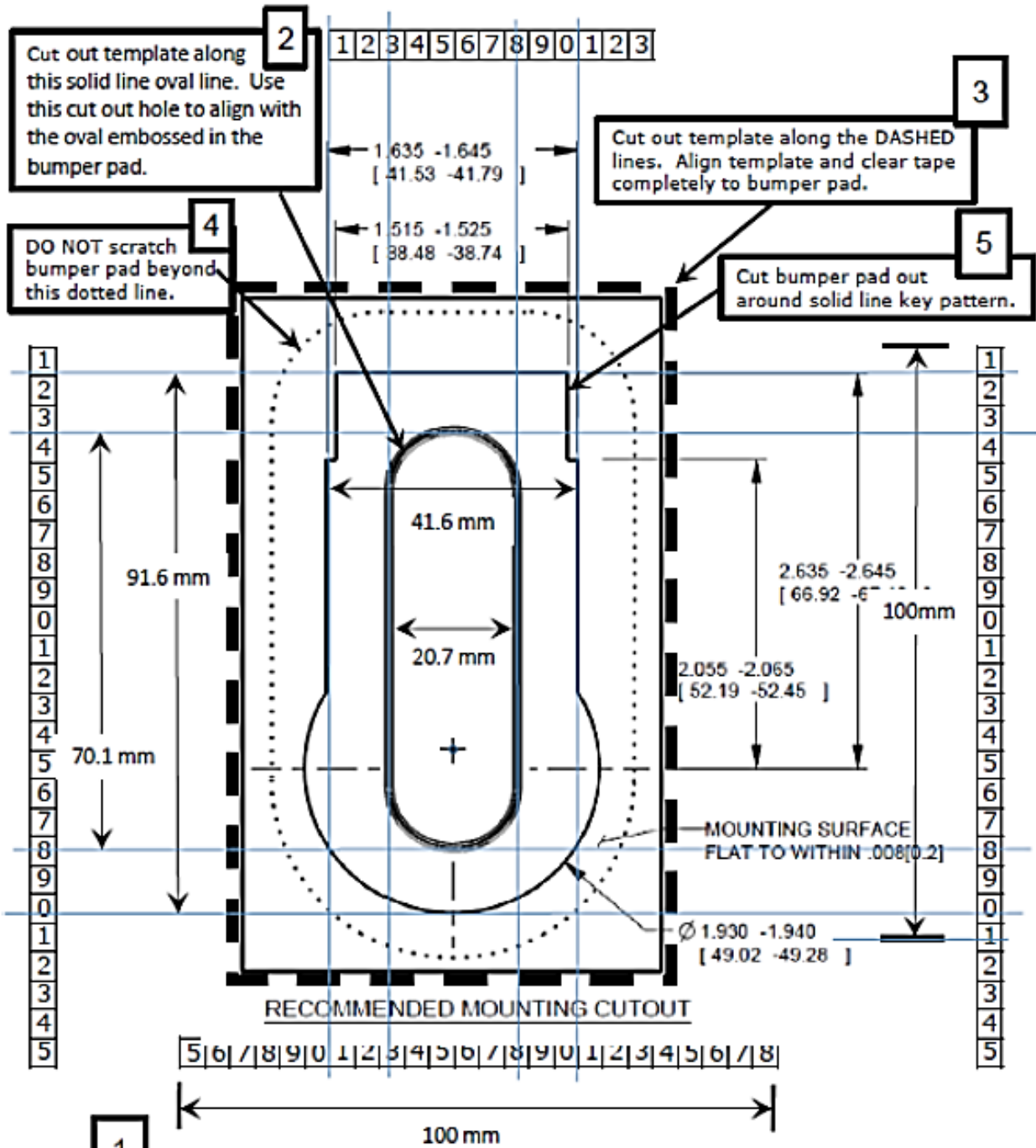

1
Print as "Actual Size" on 8 1/2 X 11" paper size for a one-to-one template.

*** NOTICE *** Read all 5 steps before proceeding with this template. Dimensions are provided for reference.

INSTALL TOW HITCH RECEIVER:

DESCRIPTION: Tow Hitch Receiver

APPLICATION: Frontier

PART NUMBER: T99T5 9BU0B

KIT CONTENTS:

Item	Qty.	Part Description	Service Part Number
A	1	Tow Hitch Receiver	T99T5 9BU00
B	10	M12 X 1.25MM X 35MM HEX BOLT	081B7 2352A
C	4	M12 HEX NUT W/FLANGE	
D	2	Bracket - Side	
E	1	Hitch Cap	999T5 KN000S2
F	1	Installation Instruction Replacement Template	999V2 AW000

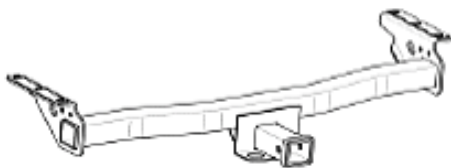

A



B



C



D



E



F

TOOLS REQUIRED:

- Safety Glasses
- Socket Wrench
- 9" Socket Extension
- 17mm Socket
- 17mm Wrench
- Torque Wrench

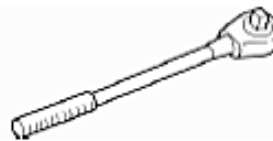

17 mm



17mm

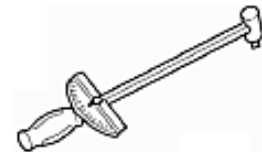

PRE-INSTALLATION WARNINGS, CAUTIONS, CRITICAL STEPS, and NOTES:

- Dealer Installation Recommended.

⚠ WARNING

- See owners manual for vehicle towing rating.
- Be careful of sharp edges and hanging components when under vehicle.
- Bolts must be tightened according to the specified torque values.
- Ensure kit components are properly stowed when not in use. Improperly stowed components could become a projectile and result in serious personal injury during a collision or sudden stop.

INSTALLATION PROCEDURE:

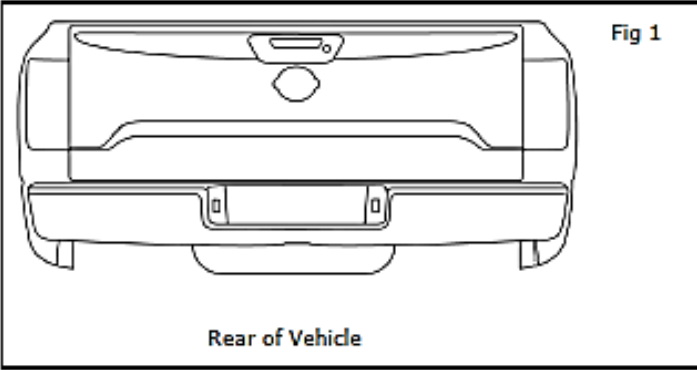

1) Raise and secure vehicle on lift.

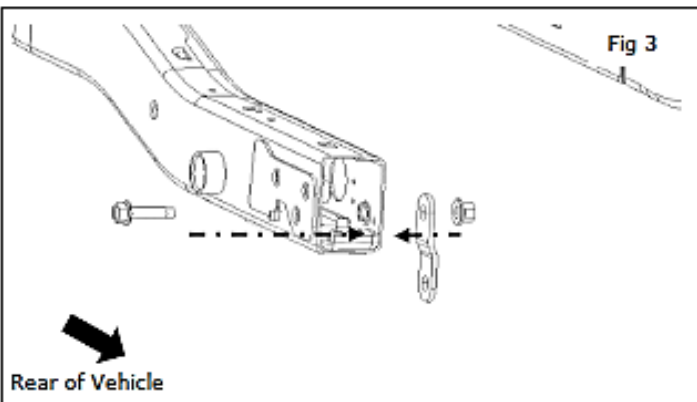
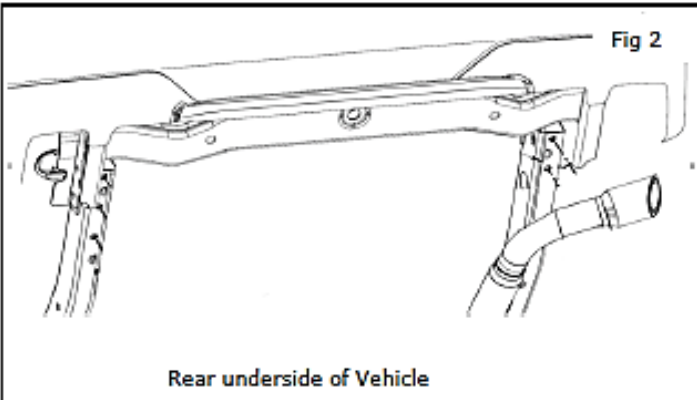

2) Install Side Brackets: Loose install 2 M12 bolts, 2 M12 nuts and 2 side brackets. Insert one M12 bolt through slot in frame. Bolt to be installed from inside of frame. See figure 3 and 4.

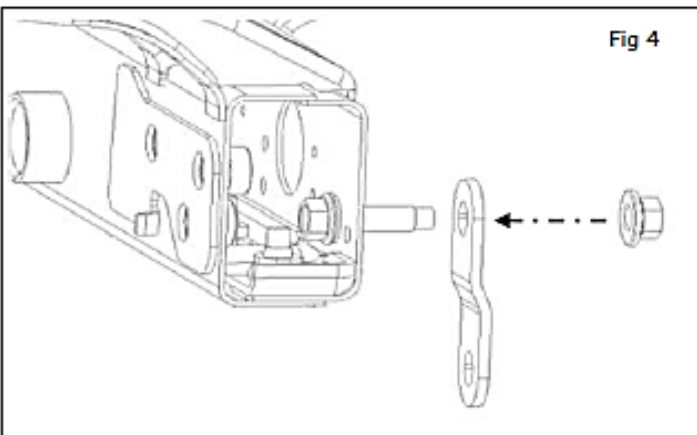

INSTALLATION PROCEDURE:

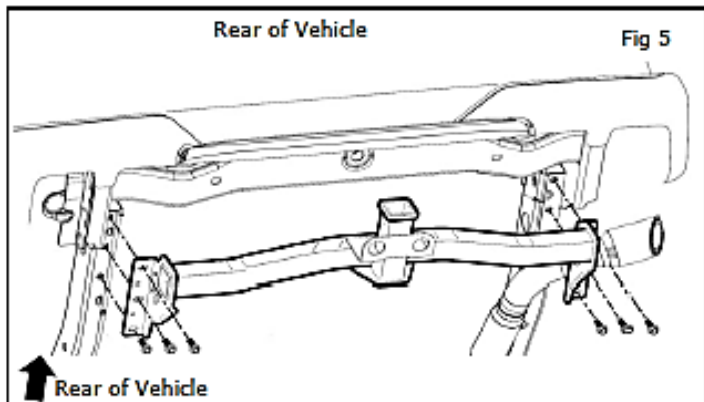

- 3) Install Tow Hitch Receiver: Carefully raise hitch receiver into position. Loose install 6 M12X35mm bolts(3lh/3rh). See Figure 2.

NOTE: This step requires two people.

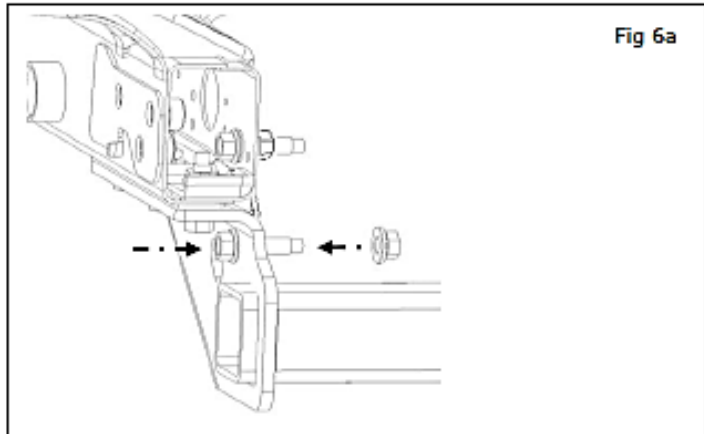

- 4) Loose install 2 M12 bolts(1lh/1rh), 2 M12 nuts(1lh/1rh) into side bracket. See figures 6a and 6b.

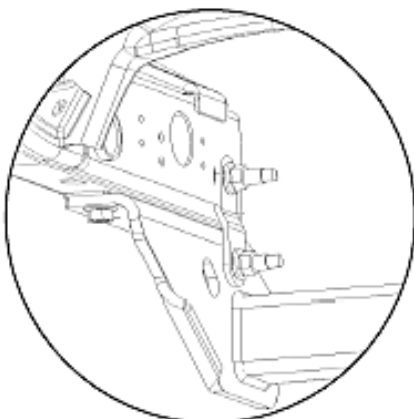
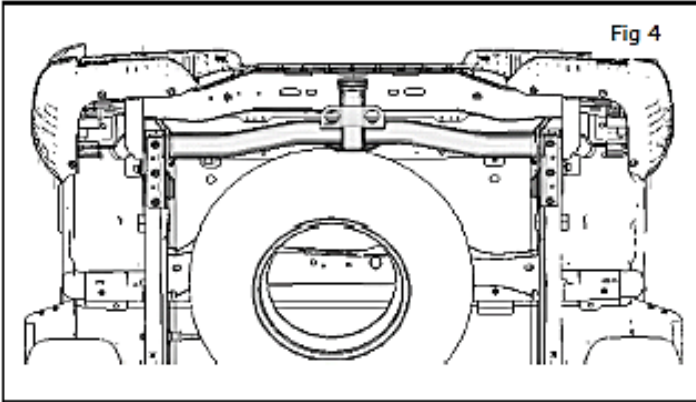
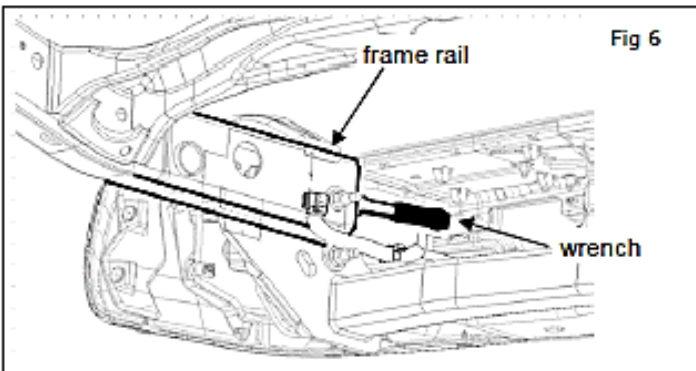
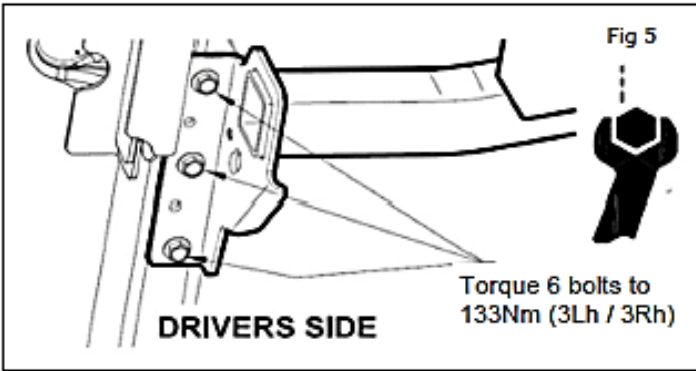

Fig 6b

INSTALLATION PROCEDURE:



- 5) **Tighten Fasteners:** Torque all 6 M12X35mm bolts to 133Nm. See Figure 4 and Figure 5.



- 6) **Tighten Fasteners:** Insert 17mm wrench into end of frame rail to hold M12 bolt. See figure 6. Using Torque wrench with 17mm socket, torque 2 upper fasteners to 133Nm. See Figure 6 and Figure 7. Then torque 2 bottom fasteners.

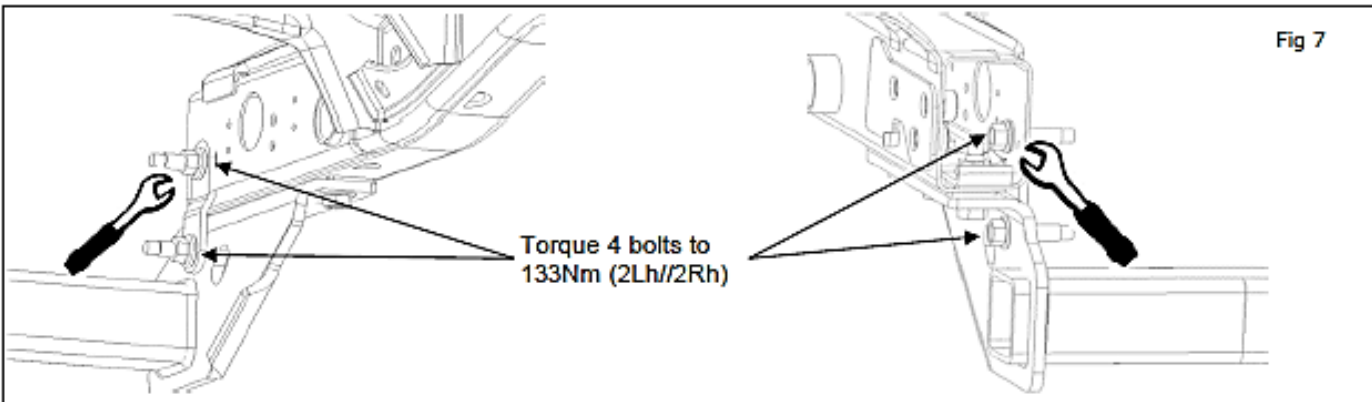

PARTS INFORMATION

Description	Part #	Quantity
Tow Harness Kit	T99T8-9BU0A	1
Tow Hitch Receiver	T99T5-9BU0B	1

CLAIMS INFORMATION

Submit a "CM" line claim using the following claims coding:

Campaign ("CM") ID	Description:	Op Code	FRT
PC843	Install Trailer Tow Harness and Tow Hitch Receiver	PC8430	1.3 Hr
