

UPS Ford F-59 CNG Project 3 Defueling Procedure

UPS Job # 20-26 P80 / # 20-27 P100 / Job # 20-28 P120

Affected Vehicles

- QTY: 800 MY2019 Ford F-59 CNG package vans
- UPS Job # 20-26 P80 / UPS Job # 20-27 P100 / UPS Job # 20-28 P120
 - UPS Package Car Ranges: 170855 – 170984
199419 – 199768
834055 – 834162
834579 – 834790

Introduction

Agility Fuel Solutions LLC, a subsidiary of Hexagon Agility Inc. (Hexagon Agility®), has established this service procedure for defueling certain UPS Ford F-59 CNG package vans (*refer to "Affected Vehicles" section above for details*).

NOTICE

Before proceeding further, please inspect the HP fuel filter (located on the driver side chassis frame rail) for the presence of a bleed valve in the filter bowl. FIGURE I-1

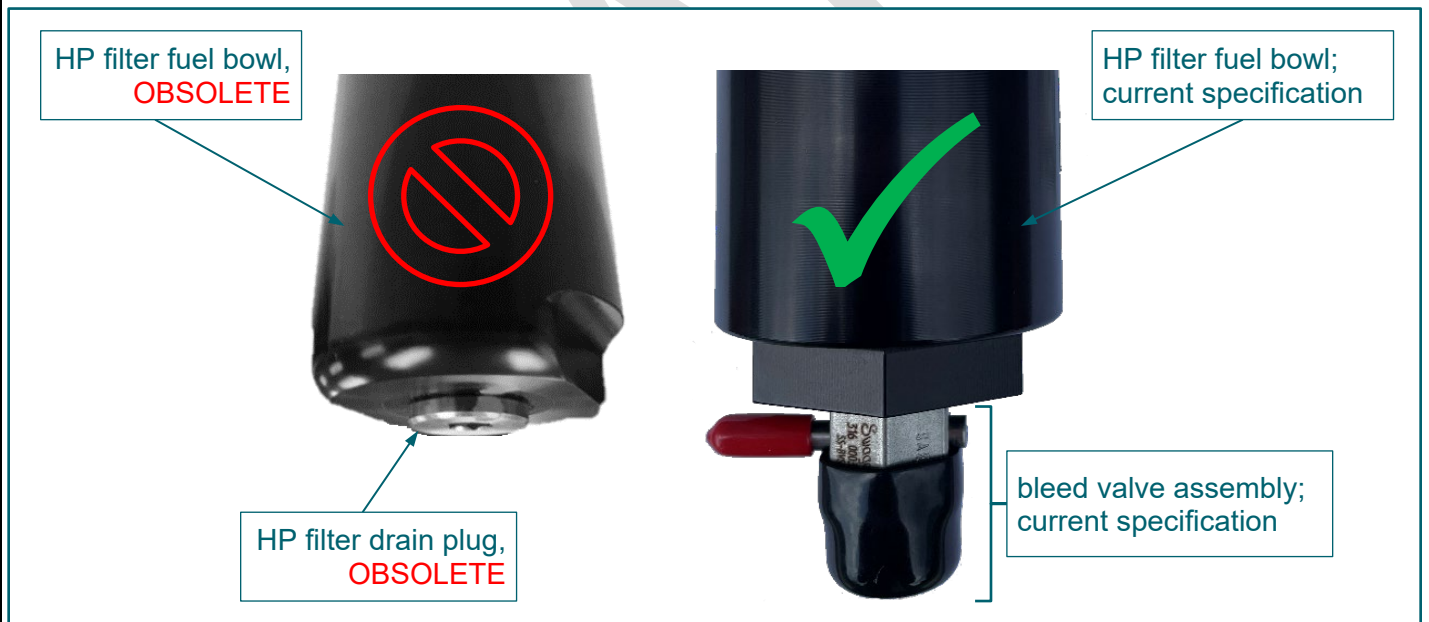





FIGURE I-1. LEFT: HP fuel filter bowl (OBSOLETE), drain plug (OBSOLETE)
RIGHT: HP filter bowl (CURRENT SPEC), bleed valve assembly (CURRENT SPEC)

NOTICE

HP filter bowl and bleed valve retrofit must be completed prior to using this procedure. Refer to FSB.0003.

Warning and Signal Words Used in this Bulletin

 WARNING	WARNING indicates a hazardous situation which, if not avoided, could result in death or serious injury.
 NOTICE	NOTICE is used to address practices not related to physical injury, such as best practices or tips to help an operation or procedure go smoothly and prevent equipment damage.
	CRITICAL CHARACTERISTIC – Product feature directly affects: <ul style="list-style-type: none"> ▪ Safety of vehicle users, people nearby and maintenance personnel, or ▪ Regulatory compliance.
	MANUFACTURING CHARACTERISTIC – <ul style="list-style-type: none"> ▪ A product feature solely used to improve manufacturability or maintain process control. ▪ A process parameter or step that has a significant effect on achieving a Critical Characteristic or Significant Characteristic, or maintaining material identification/ traceability.

Required Tools and Materials

Item	Purpose
safety glasses	eye protection
5/8-in wrench (QTY:2)	remove and replace defuel kit fitting
5/8-in wrench crowfoot wrench	use with torque wrench to tighten defuel kit fitting
7/16-in wrench	tighten bleed valve pressure relief nut
11/16-in wrench	remove and replace bleed valve
11/16-in crowfoot wrench	use with torque wrench to tighten bleed valve
torque wrench	accurately tighten fuel system fittings and components
defueling service kit, CNG – Hexagon Agility® p/n 69500019	adaptor to defuel hose, ground cable, solenoid purge harness
35-ft defueling hose – Hexagon Agility® p/n 20100021*	remove CNG from fuel system
Swagelok® Snoop® leak detection fluid	perform leak test
Torque Seal (any color but yellow)	indicate fittings are tightened to specifications
shop rags	clean fuel system components before and after repair
O-ring lubricant	lubricate O-rings for proper seating, seal, and protection

*Required if a hose is not present at defuel vent stack.

Fuel System Schematic

Item	Description
1	fuel fill panel
2	driver side (DS) cylinder
3	passenger side (PS) cylinder
4	1/4-turn manual shutoff valve
5	driver side (DS) cylinder manual valve
6	passenger side (PS) cylinder manual valve
7	HP fuel filter
8	bleed valve
9	HP fuel gauge

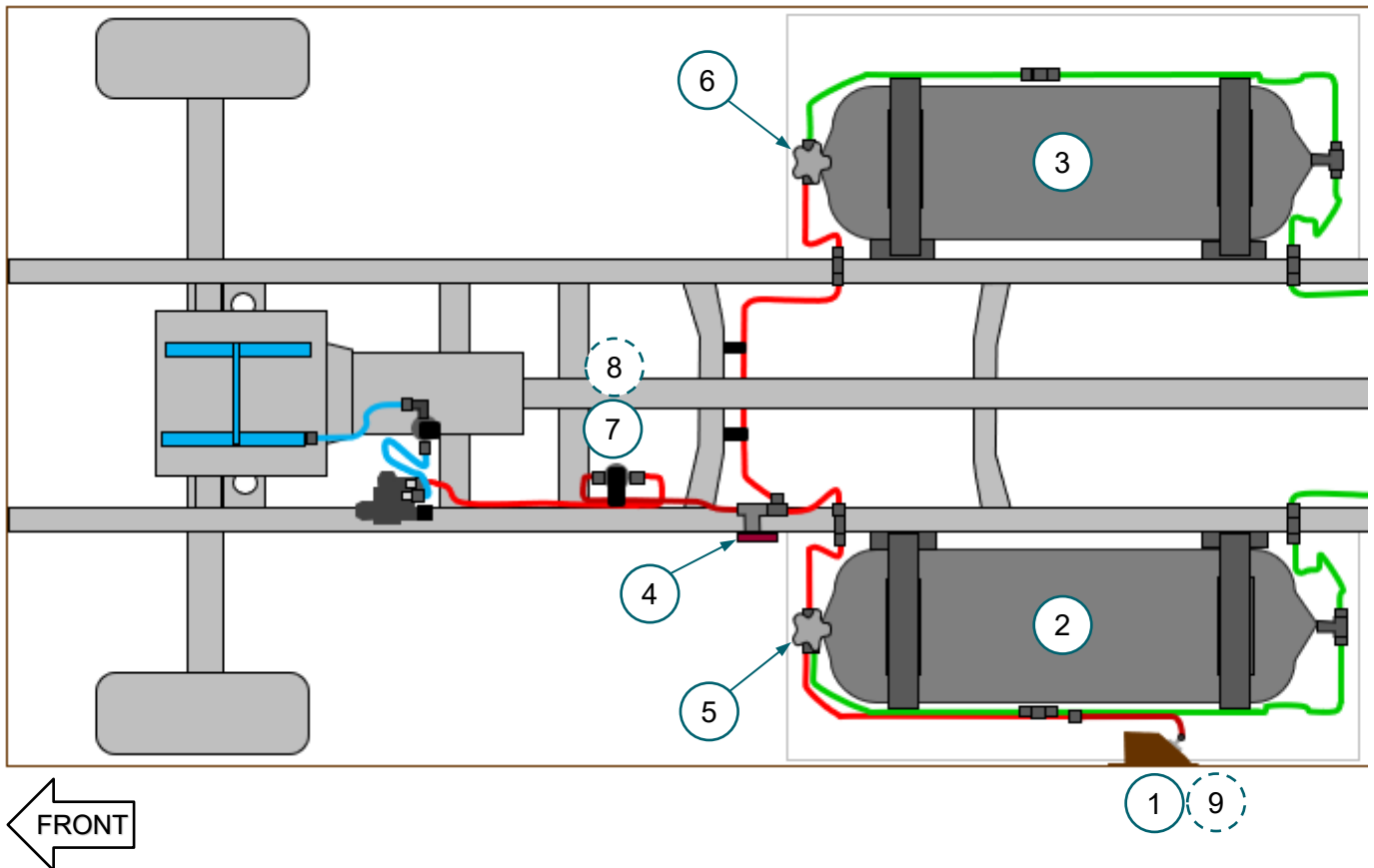

Defueling Diagram

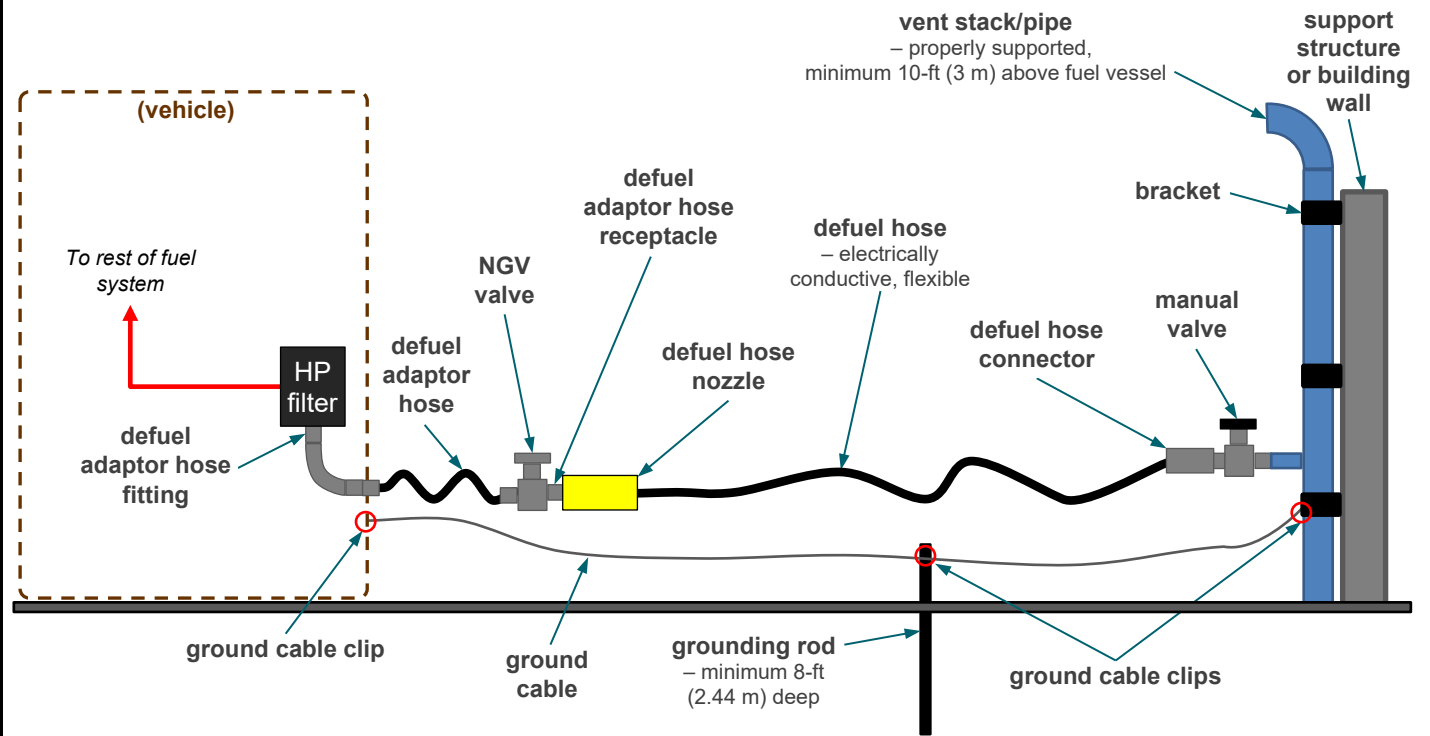

Defueling Special Tools

Item	Part Number	Description
A	69500019	Kit, defueling
B	(POA A)	Supply solenoid valve (SSV) jumper cable – <i>NOTE: not used for this procedure</i>
C	(POA A)	Ground cable
D	(POA A)	Defuel adaptor hose
E	20100021	Defueling hose, 35-ft

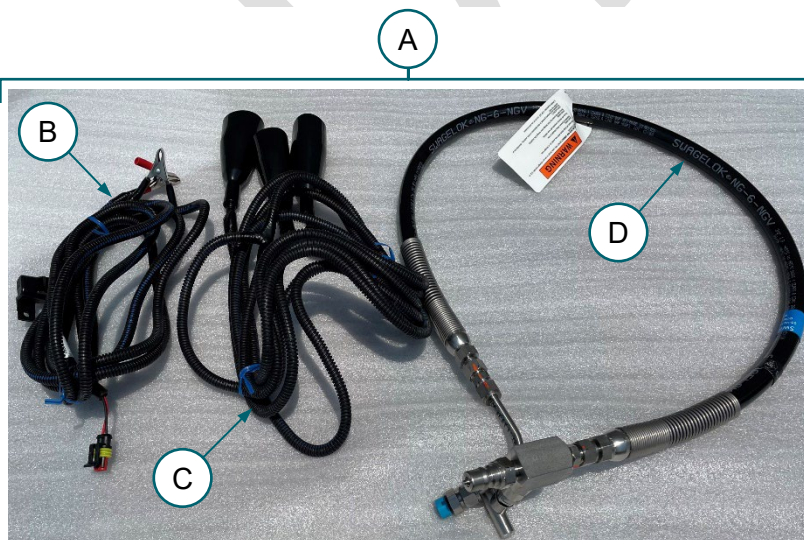

POA = part of assembly/kit; item not available separately

1. Vehicle Preparation

⚠ WARNING Set emergency brake and place wheel chocks under vehicle tires.

⚠ WARNING Wear approved personal protective equipment (PPE) including safety glasses.

⚠ WARNING Before servicing fuel system plumbing and components, fuel pressure must be released using a depressurization procedure.

2. Depressurization Procedure

⚠ WARNING Depressurization and defueling must be performed in well-ventilated area.

NOTICE Vehicle will be immobile after depressurization; plan accordingly.

1. Close driver side (DS) cylinder manual valve (5). **FIGURE 2-1**

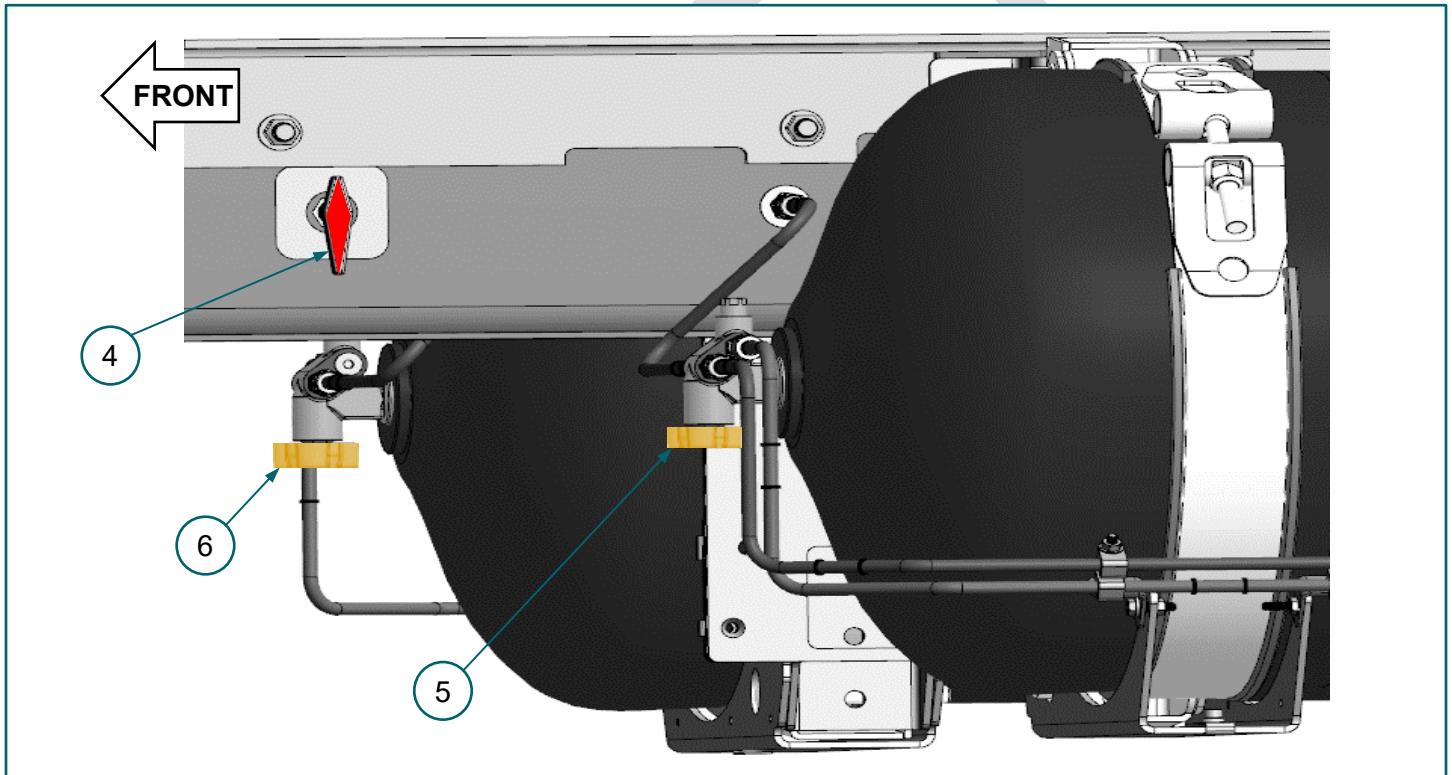

FIGURE 2-1. (5) DS manual cylinder valve, (6) PS manual cylinder valve, (4) 1/4-turn manual shutoff valve

2. Close passenger side manual valve (6). **FIGURE 2-1**
3. Close 1/4-turn manual shutoff valve (4). **FIGURE 2-1**
4. Start engine and idle until engine stalls.
5. Attempt to start engine again.
 - a. If engine starts, allow engine to idle until it stalls.
 - b. Repeat Step 5 until engine fails to start.

6. Remove bleed valve pressure relief port cap and pressure relief nut cap from (8) bleed valve located on (7) HP fuel filter. **FIGURE 2-2**

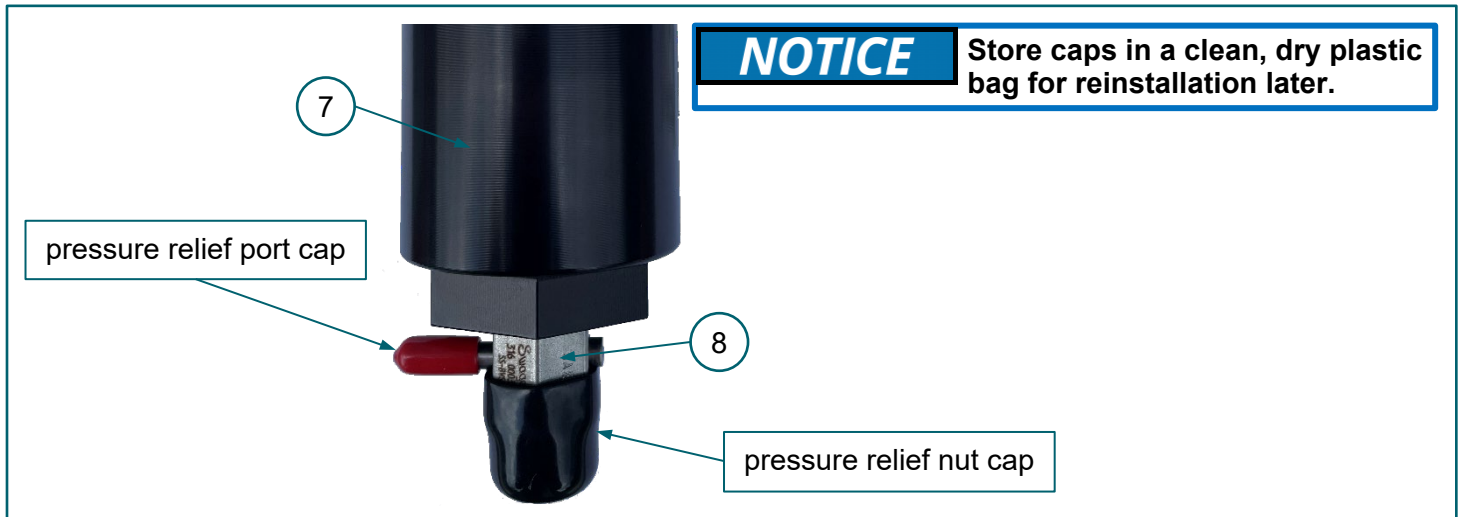

FIGURE 2-2. (7) HP fuel filter, (8) bleed valve, pressure relief port cap, pressure relief nut cap

7. Use a 7/16-in wrench to loosen pressure relief nut on the (8) bleed valve. **FIGURE 2-3**

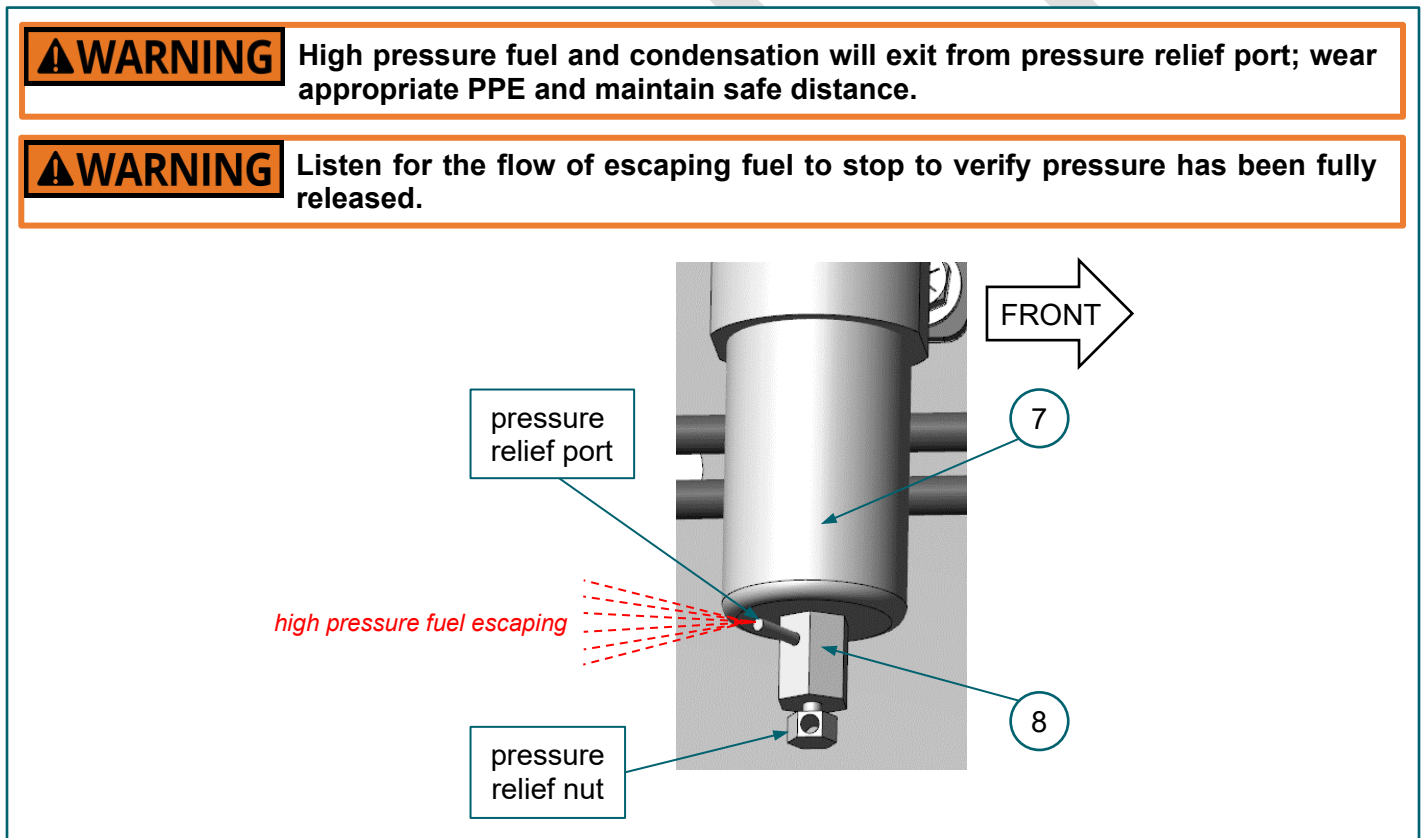

FIGURE 2-3. (7) HP fuel filter, (8) bleed valve, pressure relief nut, pressure relief port

3. Defueling Procedure

WARNING Verify (9) HP fuel gauge on (1) fuel fill panel reads approximately zero before proceeding. FIGURE 3-1

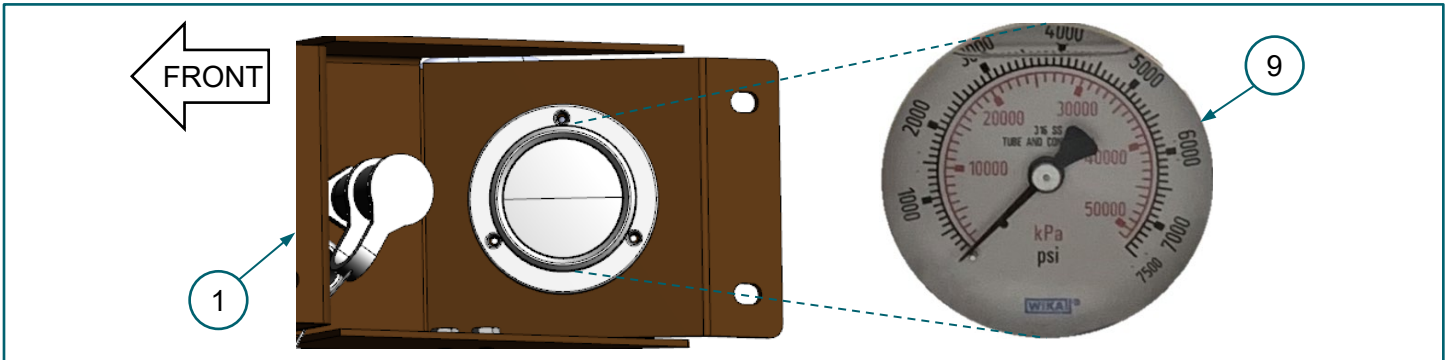

FIGURE 3-1. (1) fuel fill panel, (9) HP fuel gauge

1. Verify (5) driver side (DS) cylinder manual valve and (6) passenger side (PS) cylinder manual valve are closed. NOTE: Cylinder shields not shown. FIGURE 3-2

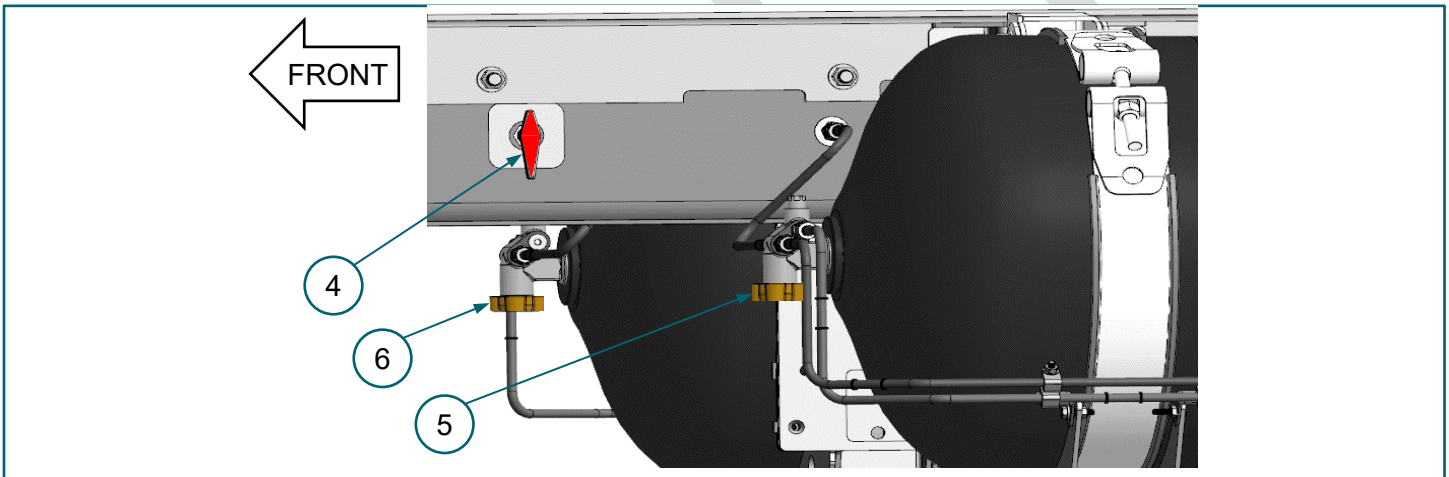

FIGURE 3-2. (4) 1/4-turn manual shutoff valve, (5) DS cylinder manual valve, (6) PS cylinder manual valve

2. Verify (4) 1/4-turn manual shutoff valve is closed. FIGURE 3-2

3. Use an 11/16-in wrench to remove bleed valve (8) from (7) HP fuel filter. FIGURE 2-5

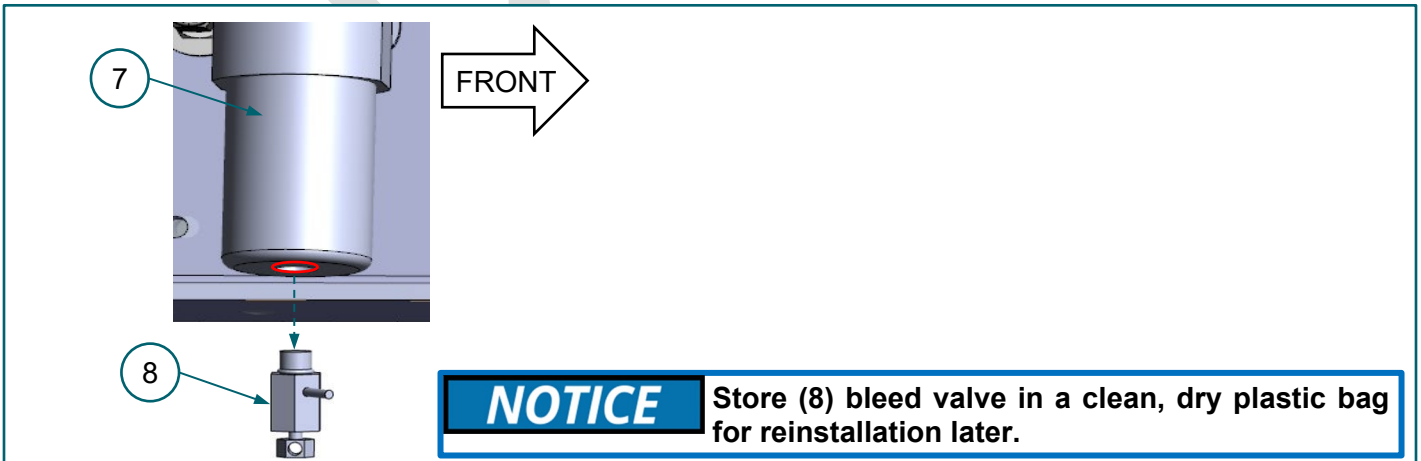

FIGURE 3-5. (7) HP fuel filter, (8) bleed valve

4. Select defuel hose adaptor from defueling service kit, CNG – Hexagon Agility p/n 69500019. FIGURE 2–6

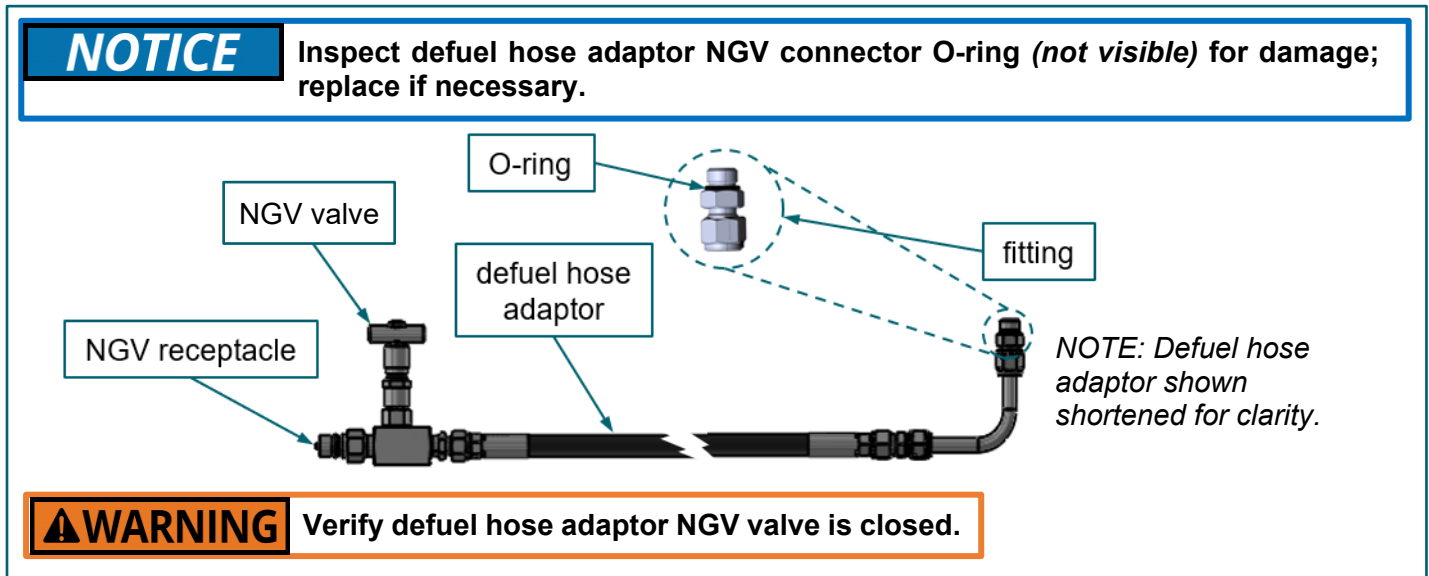

FIGURE 3–6. Defuel hose adaptor components

5. Remove fitting from defuel hose adaptor using a pair of 11/16-in wrenches. FIGURE 3–6



Verify fitting O-ring and sealing surfaces are clean and free of debris.



Apply a light coat of O-ring lubricant to fitting O-ring before installing in HP fuel filter bowl port.

6. Install fitting in (7) HP fuel filter bowl port (*circled*) using a 5/8-in socket or crows foot wrench. FIGURE 3–7

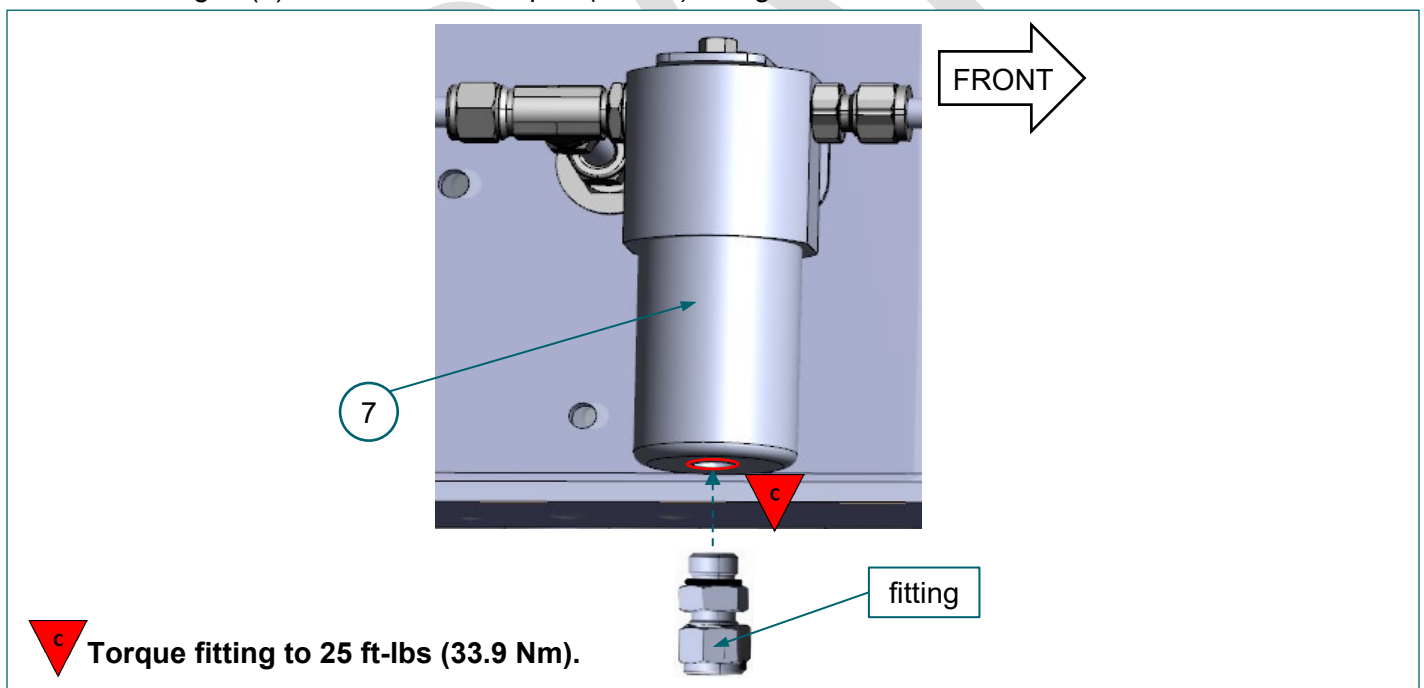

FIGURE 3–7. (7) HP fuel filter, filter bowl drain port (*red oval*), fitting

7. Attach defuel hose adaptor end to fitting using a 5/16-in wrench and a 11/16-in wrench. **FIGURE 3–8**

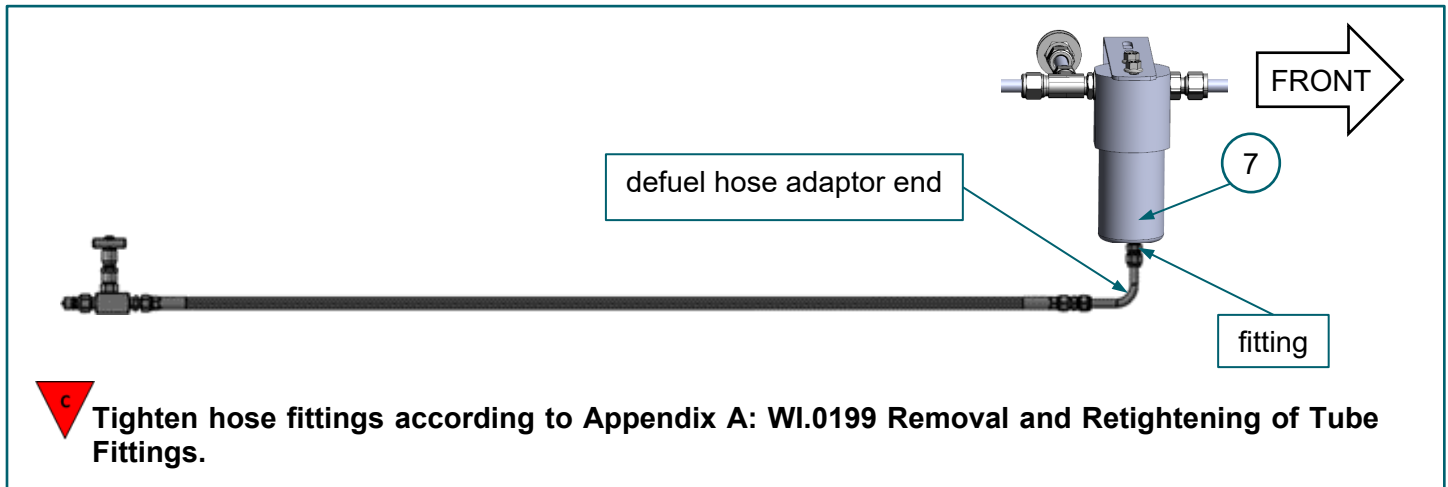

FIGURE 3–8. (7) HP fuel filter with fitting and defuel hose adaptor attached

8. Attach fuel facility ground cable clips to the following locations: (a) known good vehicle ground, (b) vent stack ground, and, if present, connect (c) third ground cable clip to a dedicated ground rod. **FIGURE 2–9**

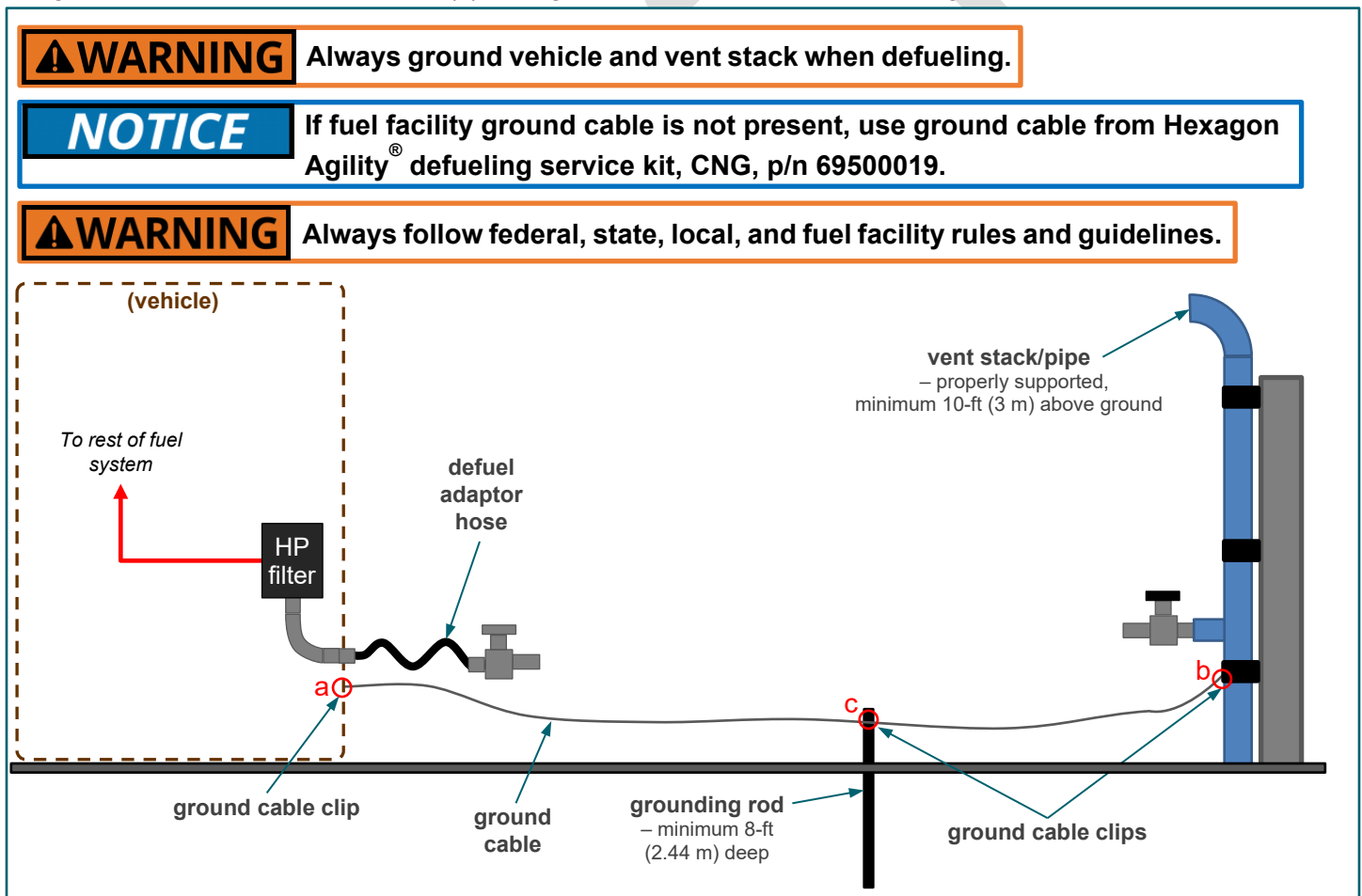

FIGURE 3–9. Ground cable clip attachment locations

9. Attach connector end of defuel hose to vent stack receptacle. NOTE: Use Hexagon Agility® defuel hose p/n 20100021 if hose is not provided. **FIGURE 3-10**

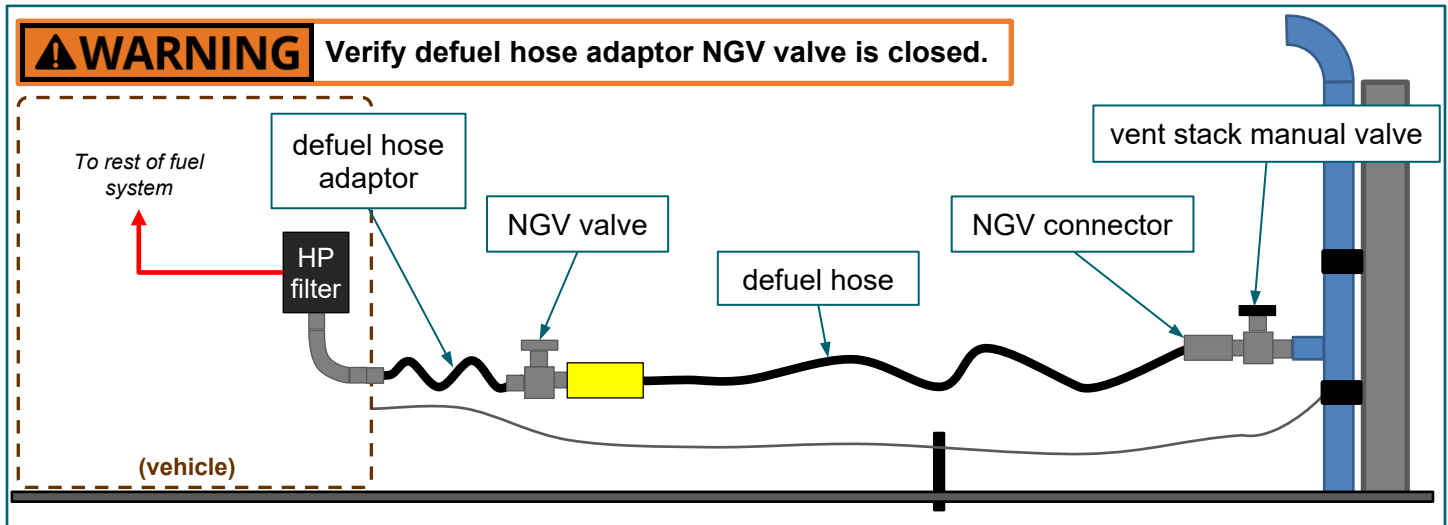

FIGURE 3-10. Defuel hose adaptor; defuel hose NGV connector end attached to vent stack receptacle

10. Open (5) DS cylinder manual shutoff valve. NOTE: Cylinder shield not shown. **FIGURE 3-11**

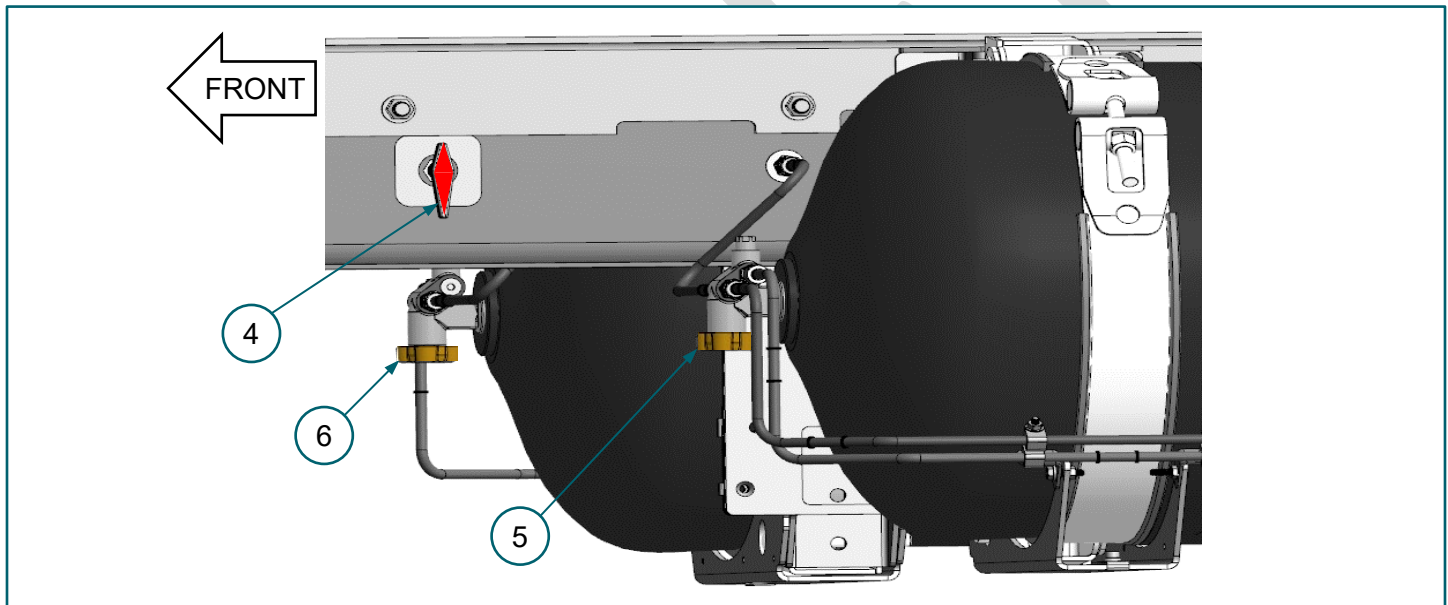

FIGURE 3-11. (4) 1/4-turn manual shutoff valve, (5) DS cylinder manual valve, (6) PS cylinder manual valve

11. Open (6) PS cylinder manual shutoff valve. NOTE: Cylinder shield not shown. **FIGURE 3-12**

12. Spray Swagelok Snoop® on all defuel hose adaptor fitting connections **FIGURE 3-12**

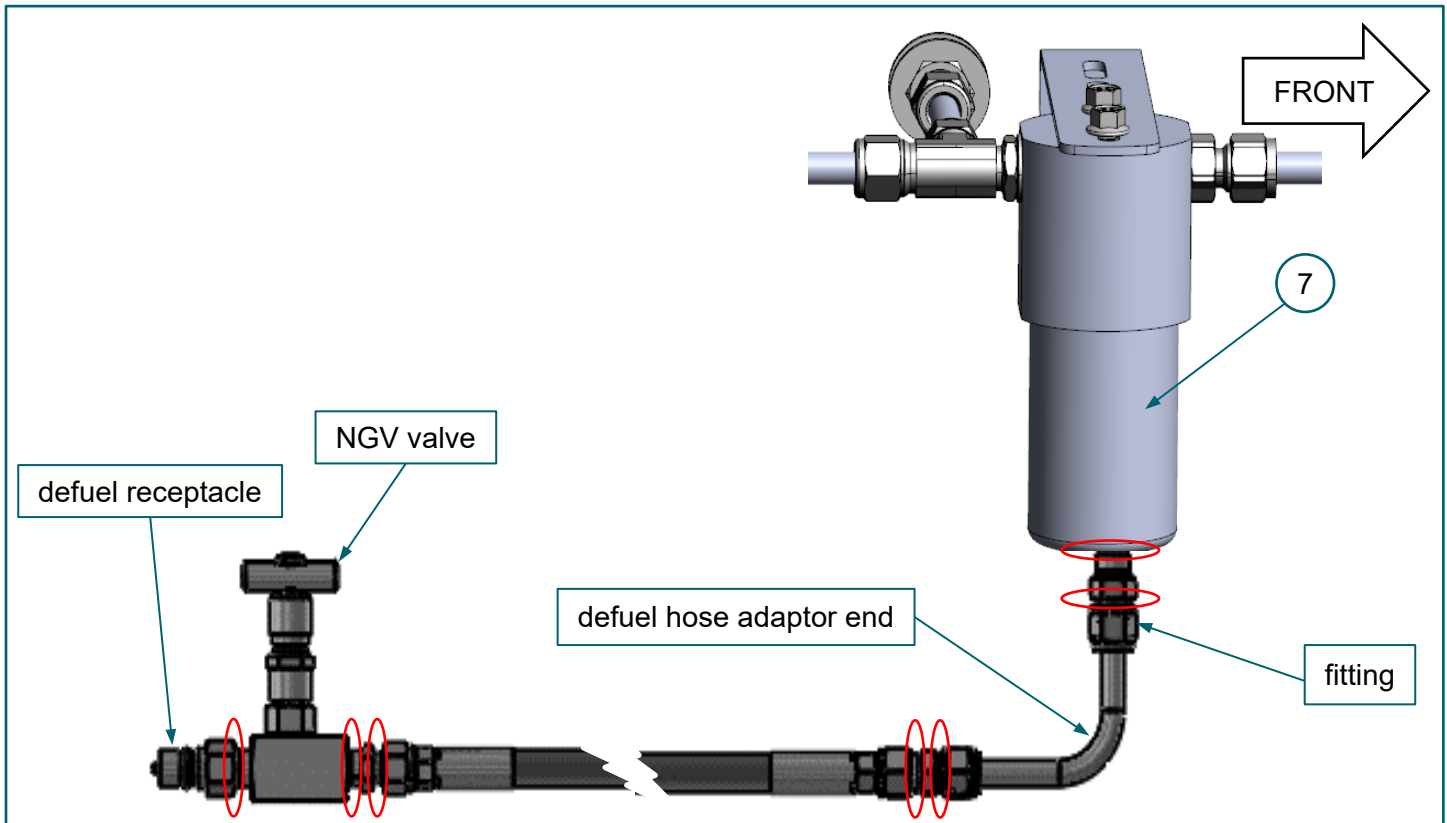

FIGURE 3-12. (7) HP fuel filter, fitting, defuel receptacle, NGV valve, defuel hose adaptor connections (*circled*) to be leak checked

13. SLOWLY open 1/4-turn manual shut off valve and wait 3 minutes to check for bubbles as a sign of a leak.
FIGURE 3-13

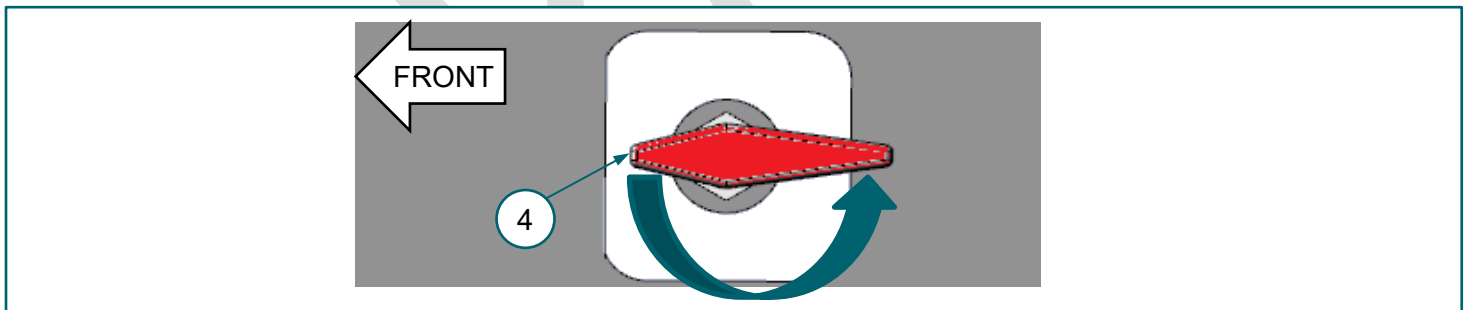

FIGURE 3-13. (4) 1/4-turn manual shutoff valve in the OPEN position

If a leak is found:

- a. Close 1/4-turn manual shutoff valve. **FIGURE 3-14**

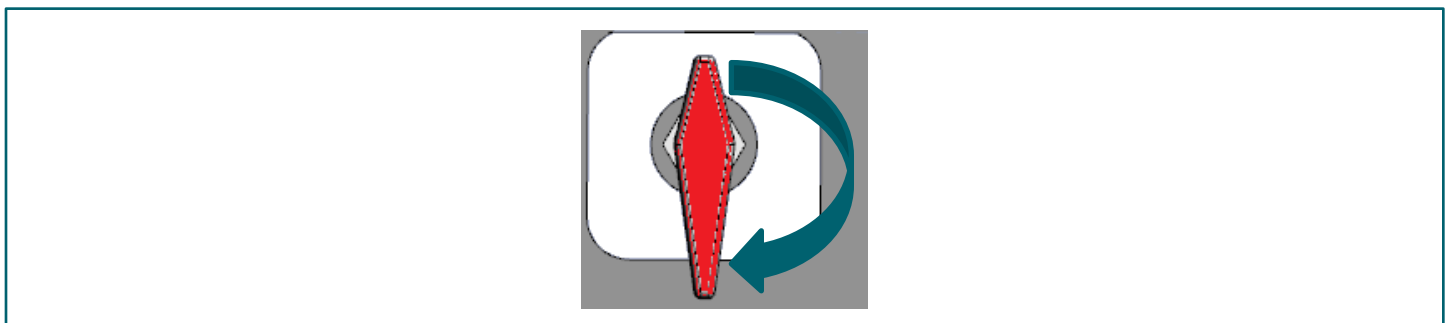

FIGURE 3-13. 1/4-turn manual shutoff valve in CLOSED position

b. Disconnect defuel adaptor hose from defuel hose. **FIGURE 3-14**

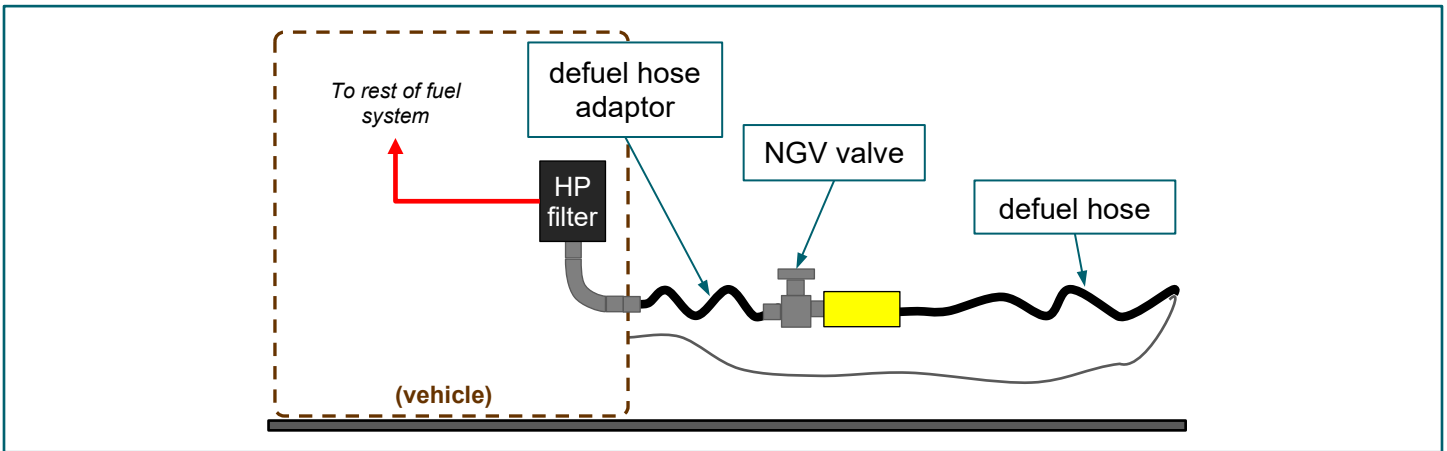

FIGURE 3-14. Defuel adaptor hose, NGV valve, defuel hose

c. SLOWLY open defuel adaptor hose NGV valve. **FIGURE 3-14**

⚠ WARNING Allow all pressure to be released before proceeding.

d. Tighten fitting(s) according to **Appendix A: WI.0199 Removal and Retightening of Tube Fittings (below)**.

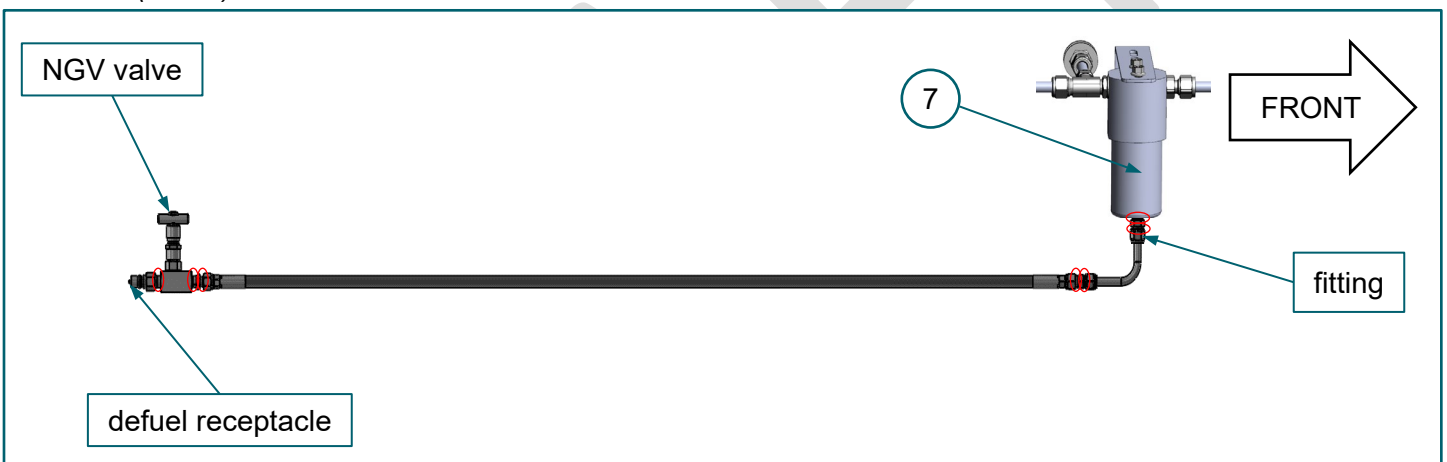

FIGURE 3-14. (7) HP fuel filter, fitting, defuel receptacle, NGV valve, defuel hose adaptor fitting connections (circled) to be tightened

e. **Once repair is complete**, open 1/4-turn manual shutoff valve and proceed to Step 16. **FIGURE 3-16**

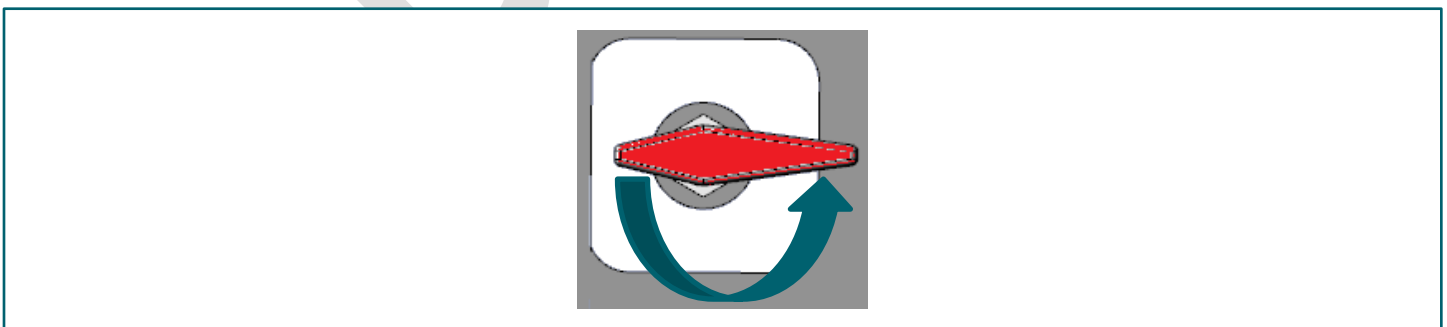

FIGURE 3-16. 1/4-turn manual shutoff valve in OPEN position

14. SLOWLY open defuel hose adaptor NGV valve. **FIGURE 3-14**

NOTICE

If defueling rate is too rapid, the excess flow valve will close and prevent defueling. Wait approximately five minutes for excess flow valve to reset and adjust defuel hose adaptor NGV valve for lesser flow before resuming defuel.

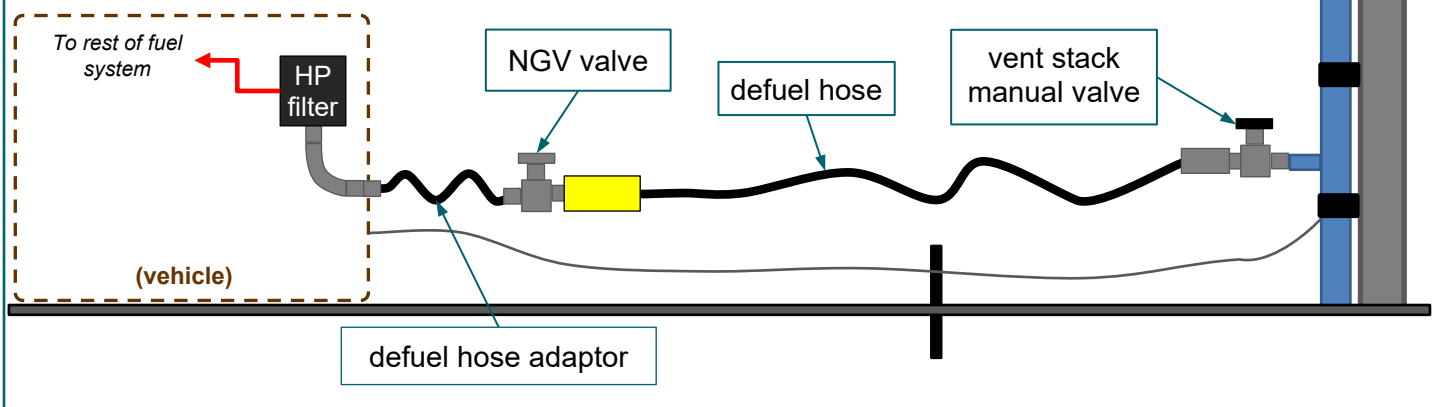

FIGURE 3–14. Defuel hose NGV connector end attached to vent stack manual valve

15. SLOWLY open vent stack manual valve. FIGURE 3–14

16. Monitor system fuel level on (1) fuel fill panel (9) HP fuel gauge until it reads zero. FIGURE 3–15

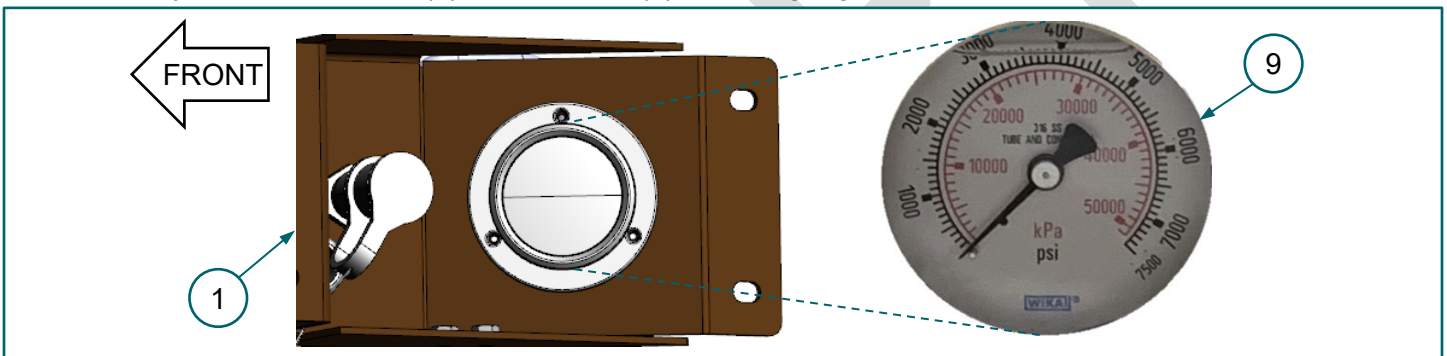

FIGURE 3–15. (1) fuel fill panel, (9) HP fuel gauge

17. Disconnect NGV connector end of defuel hose from vent stack receptacle. FIGURE 3–16

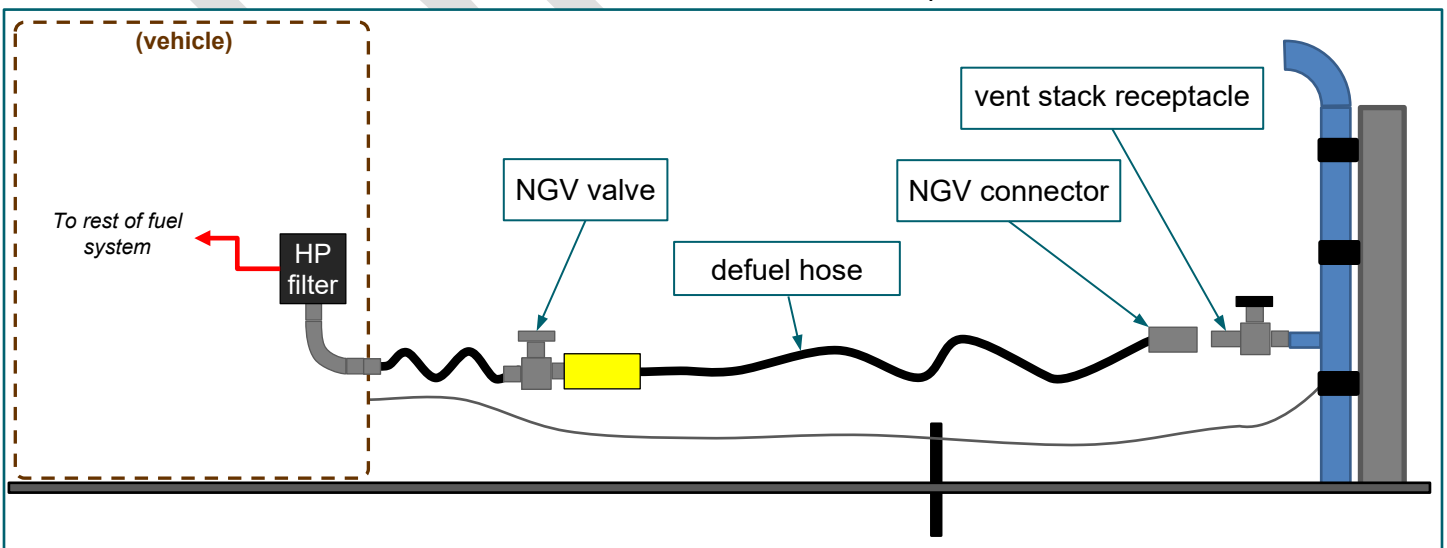

FIGURE 3–16. Defuel hose adaptor NGV valve, defuel hose, NGV connector, vent stack receptacle

18. Disconnect defuel hose adaptor from defuel hose. FIGURE 3–16

19. If using fuel facility ground cable: Detach ground cable clips (locations circled) from vehicle ground and vent stack ground and proceed to Step 23. **FIGURE 3–17**

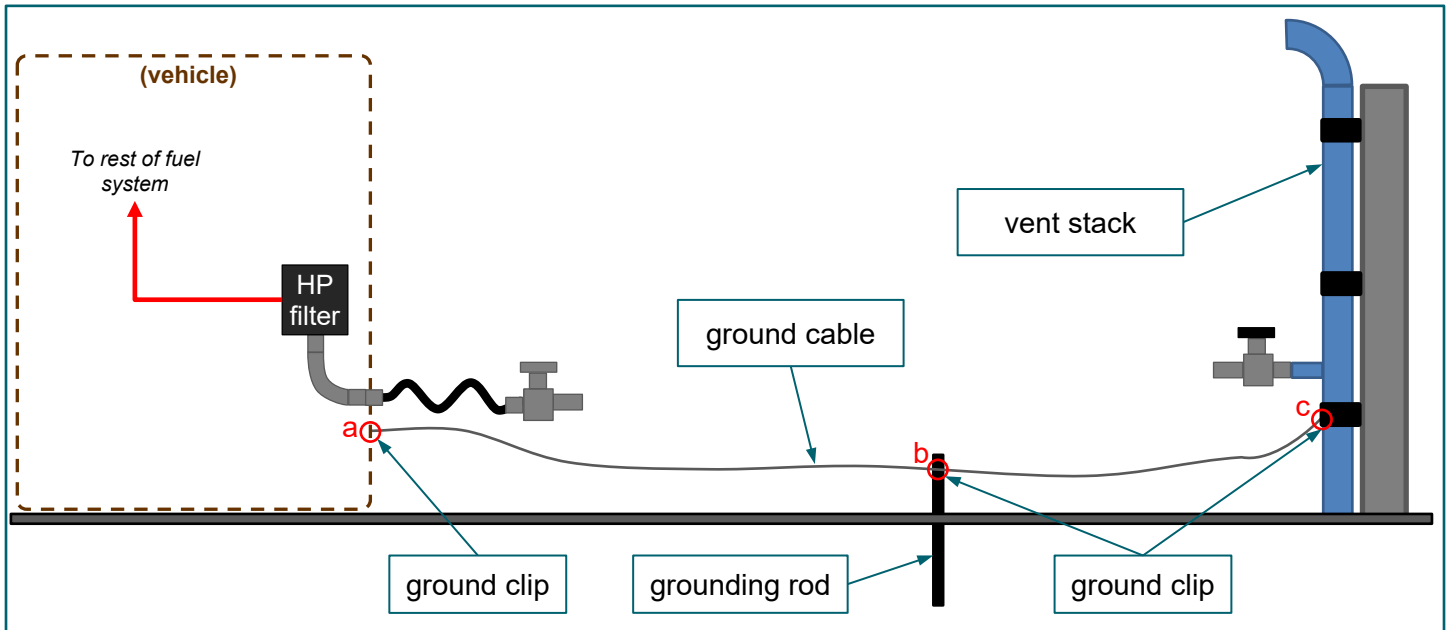

FIGURE 3–17. Ground cable clip locations: (a) vehicle, (b) grounding rod, (c) vent stack

20. If using ground cable from Hexagon Agility p/n 69500019 defuel kit: Detach ground cable clips (locations circled) from vehicle ground, grounding rod (if present), and vent stack ground. **FIGURE 3–17**

21. Remove fitting from defuel hose adaptor end using a. **FIGURE 3–18**

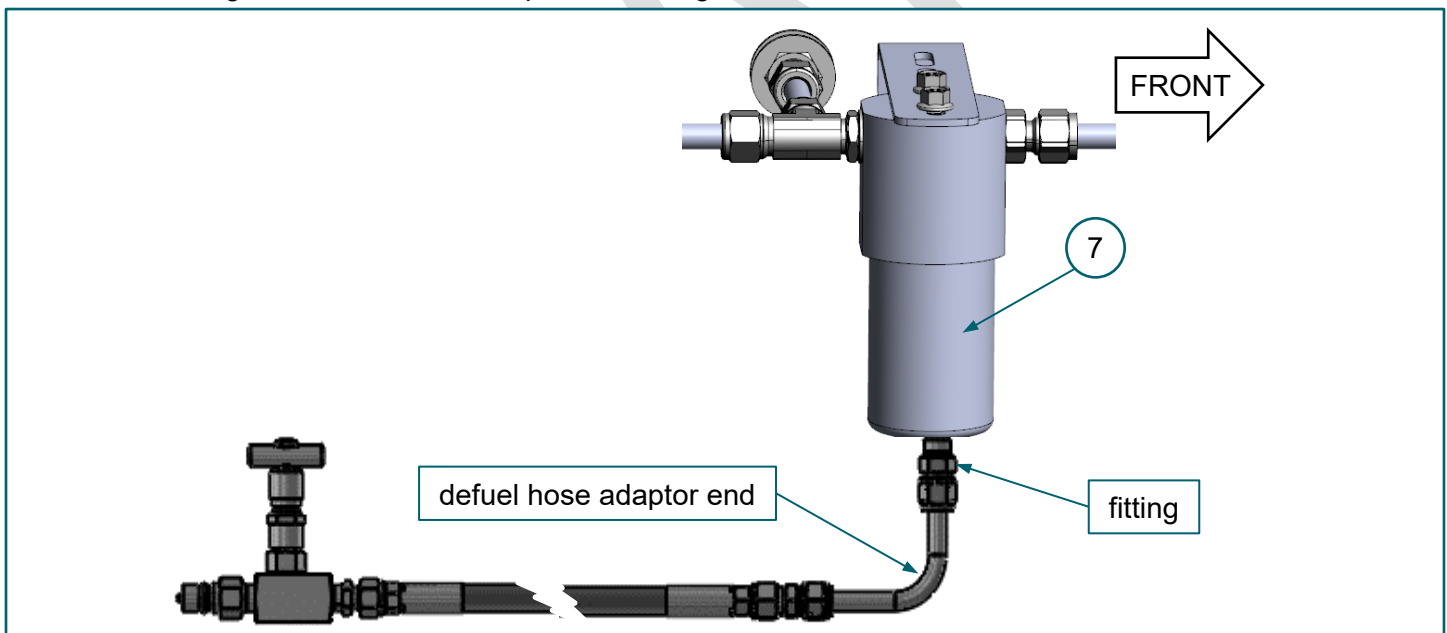

FIGURE 3–18. (7) HP fuel filter, fitting, defuel hose adaptor end

22. Use a 5/8-in wrench to remove fitting from (7) HP fuel filter. **FIGURE 3–18**

23. Reattach fitting to defuel hose adaptor using a 5/8-in wrench and an 11/16-in wrench. **FIGURE 3–18**

24. Retrieve (8) bleed valve (stored earlier) and inspect O-ring for damage or wear. **FIGURE 3–19**

⚠ WARNING Replace bleed valve if O-ring is damaged.

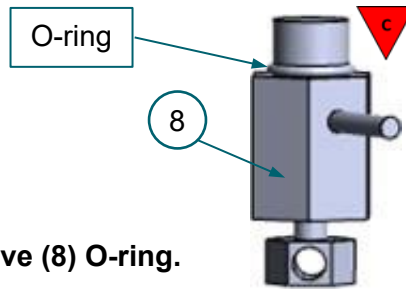

⚠ Apply O-ring lube to bleed valve (8) O-ring.

FIGURE 3–19. (8) bleed valve, O-ring

25. Apply O-ring lubricant to (8) bleed valve O-ring. FIGURE 3–19

26. Use an 11/16-in wrench to reinstall (8) bleed valve in (7) HP fuel filter bowl port (*circled*). FIGURE 3–20

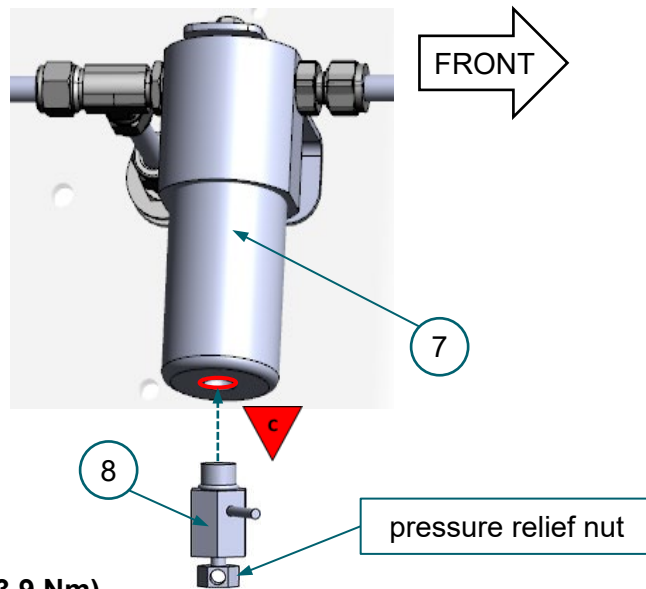

⚠ Torque bleed valve (8) to 25 ft-lbs (33.9 Nm).

FIGURE 3–20. (7) HP fuel filter, (8) bleed valve

27. Close (8) bleed valve pressure port relief nut finger tight. FIGURE 3–21

⚠ To increase service life, ensure proper valve performance, and prevent leakage, apply only enough torque to pressure relief nut as required to achieve positive shutoff per Swagelok® instructions.

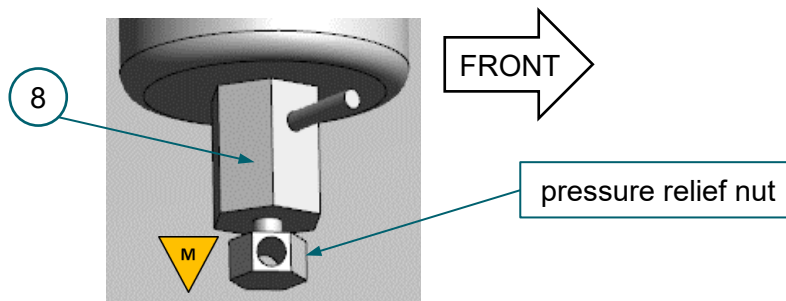

FIGURE 3–21. (8) bleed valve, pressure relief nut

28. Use a 7/16-in wrench to tighten (8) bleed valve pressure port relief nut. FIGURE 3–21

29. Install pressure relief port cap on (8) bleed valve pressure relief port and bleed valve cap and pressure relief nut. **FIGURE 3–22**

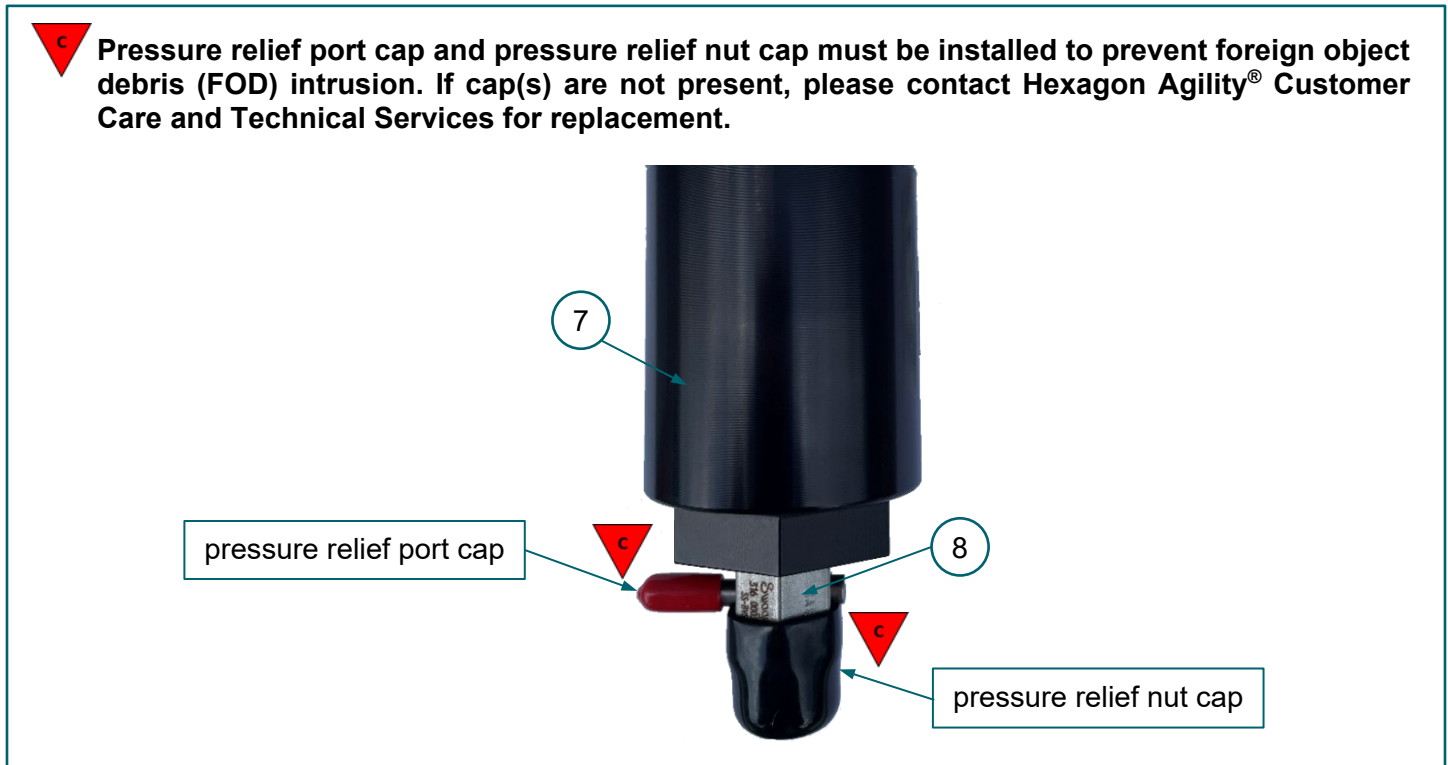

FIGURE 3–22. (7) HP fuel filter, (8) bleed valve, pressure relief port cap, pressure relief nut cap

30. Vehicle is now defueled and all removed components have been reinstalled; perform repairs as required before performing a leak test on the fuel system.

⚠️ WARNING Leak test (*below*) must be performed before vehicle may be cleared for operation.

4. Leak Test Procedure

1. Verify DS manual cylinder valve is open. **FIGURE 4-1**

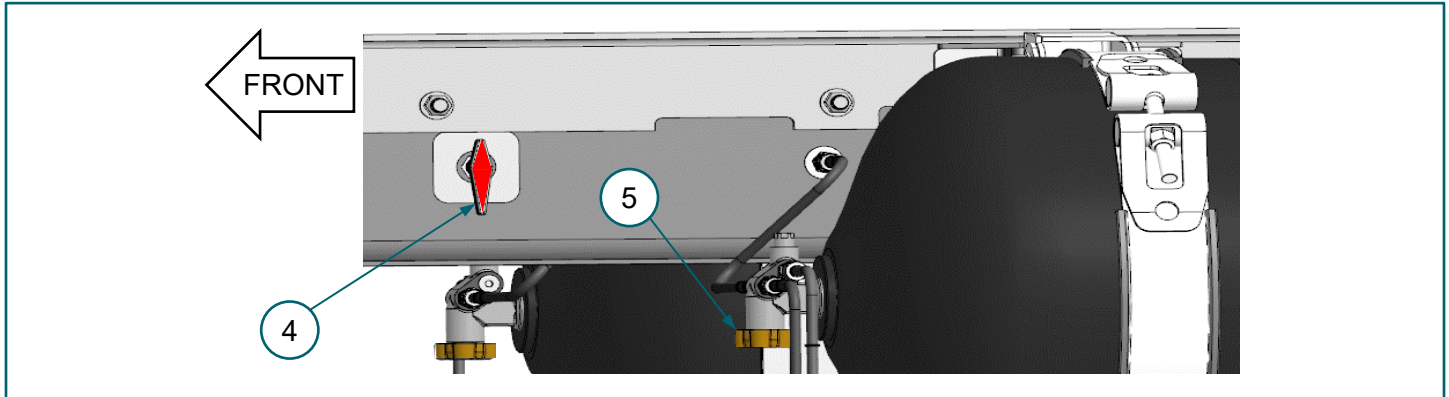

FIGURE 4-1. (4) 1/4-turn manual shutoff valve, (5) DS cylinder manual valve

2. Fuel vehicle to 500 psi (3.45 MPa). Refer to *ENP-516, Truck and Tractor CNG Fuel System Operation, Maintenance & Inspection Manual*, "CNG System Fueling" section. **FIGURE 4-2**

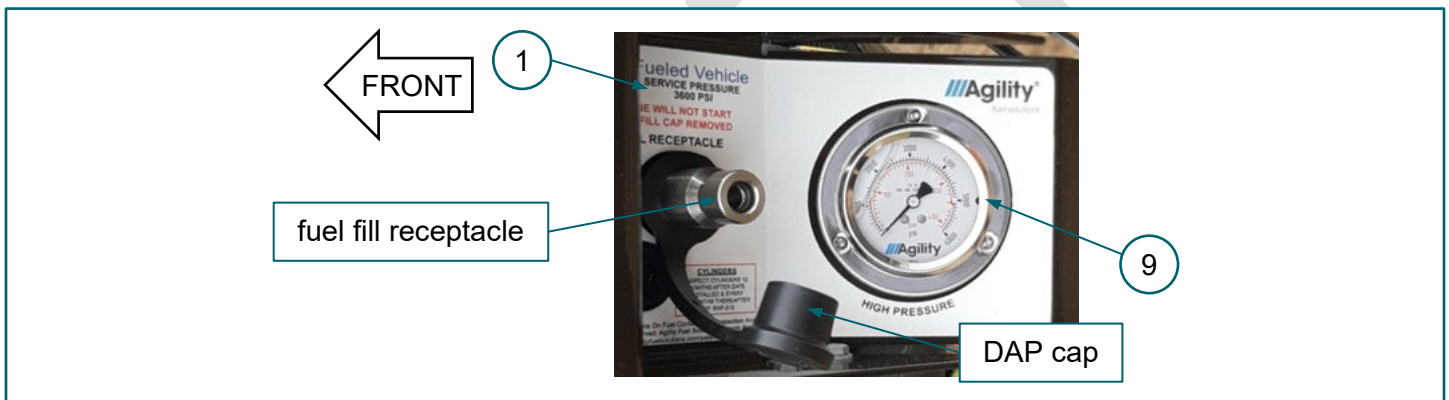

FIGURE 4-2. (1) fuel fill panel, (9) HP gauge, fuel fill receptacle, Drive Away Protection (DAP) cap, *NOTE: cap removed*

3. Open 1/4-turn manual shutoff valve. **FIGURE 4-3**

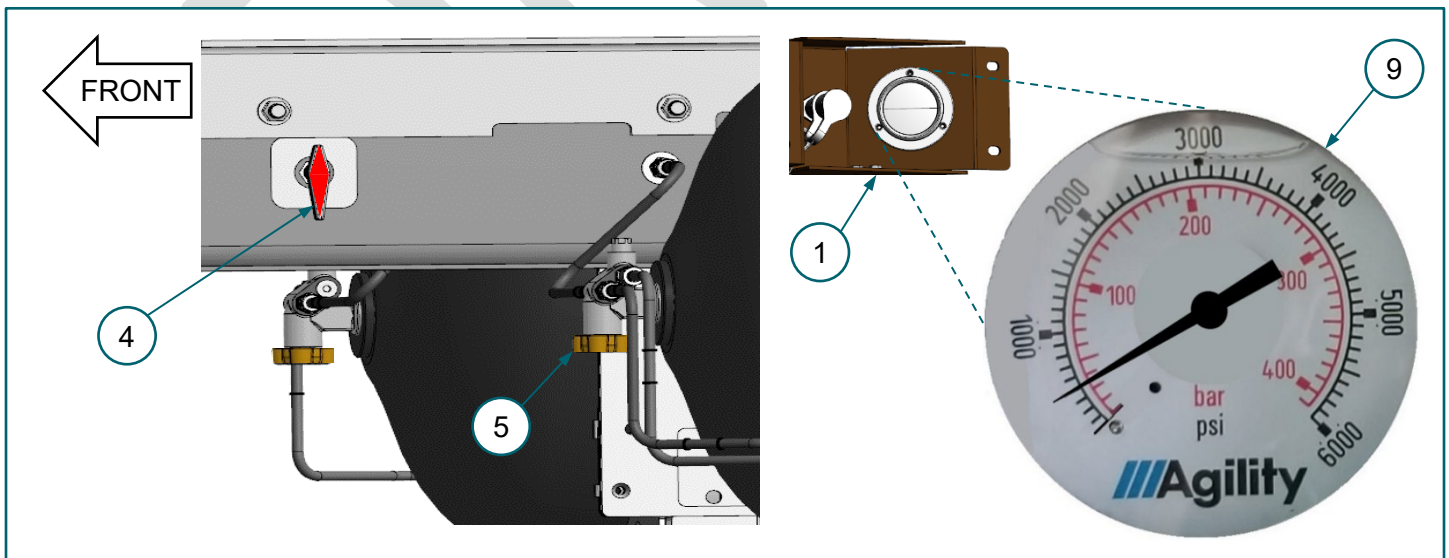

FIGURE 4-3. Fuel fill panel, (9) HP gauge reading 500 psi, (4) 1/4-turn manual shutoff valve, (5) DS cylinder manual valve

4. While observing HP gauge on fuel fill panel, have an assistant **SLOWLY** open the DS cylinder manual valve until it reads 500 psi (3.45 MPa) then direct the assistant to close the DS cylinder manual valve. **FIGURE 3-3**

- Listen for hissing as a sign of a system leak.

⚠ WARNING STOP fuel fill immediately if loud hissing indicative of a fuel system leak is audible.

- Apply Swagelok® Snoop® leak detection solution to all fuel system connections and wait 3 minutes. **FIGURE 4-4**

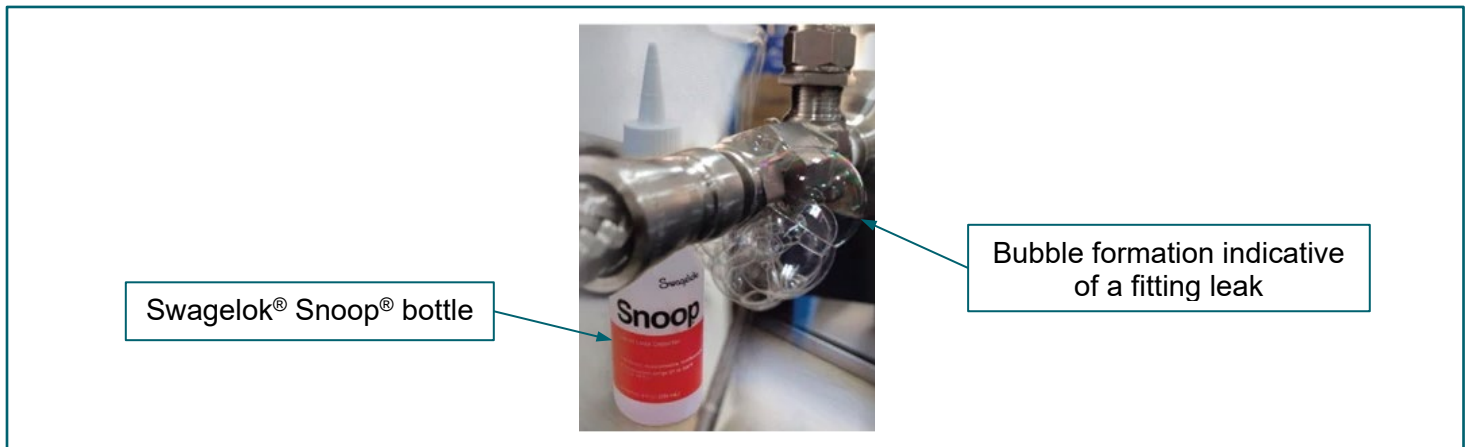

FIGURE 4-4. Swagelok® Snoop®, bubbles forming at a fitting junction

- Inspect all fuel system junctions for bubbles as an indicator of a leak. **FIGURE 3-4**
 - If no leaks are found, proceed to next step.
 - If a leak is found, depressurize fuel system. Refer to **Section 2** (above).

⚠ WARNING NEVER attempt to tighten fittings while system is pressurized.

- Repair leak(s) before repeating **Leak Test Procedure**. Refer to ENP-516, *Truck and Tractor CNG Fuel System Operation, Maintenance & Inspection Manual*, "Leak Repair" section.
- Fuel vehicle to 1800 psi (12.4 MPa). **FIGURE 3-5**. Refer to ENP-516, *Truck and Tractor CNG Fuel System Operation, Maintenance & Inspection Manual*, "CNG System Fueling" section.

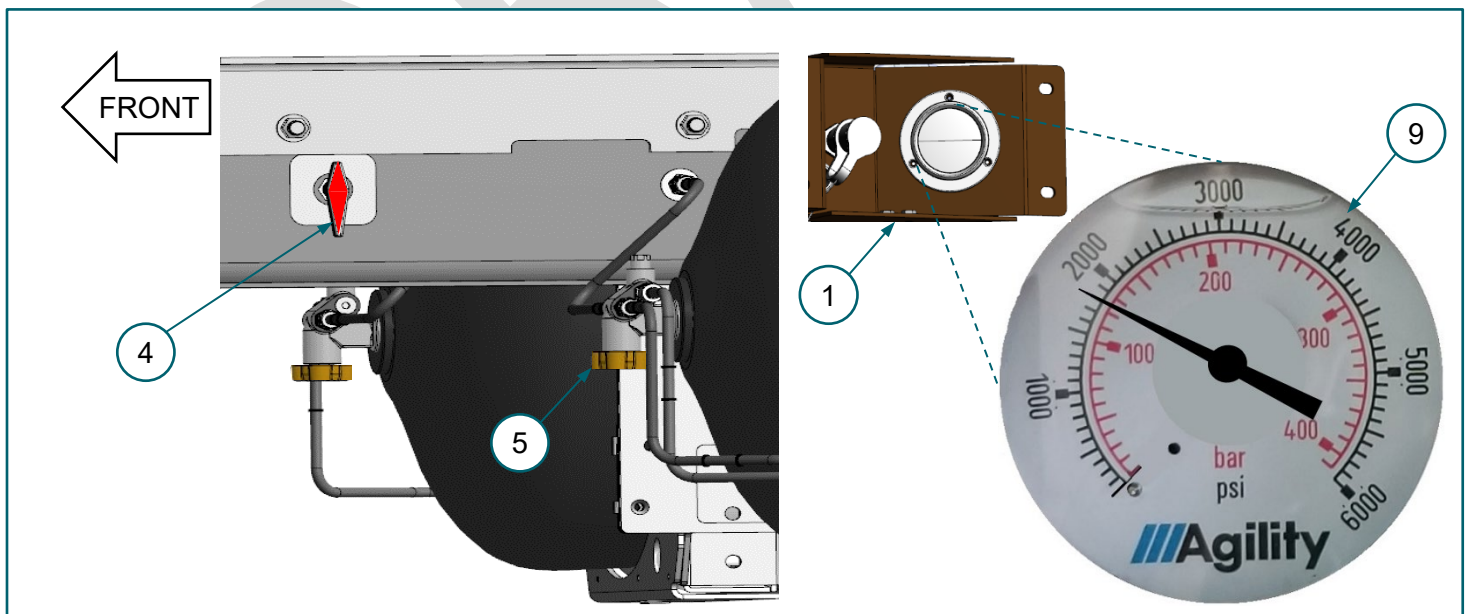

FIGURE 4-5. Fuel fill panel, (9) HP gauge reading 1800 psi, (4) 1/4-turn manual shutoff valve, (5) DS cylinder manual valve

- Repeat Steps 6 and 7 until no leaks are present, then proceed to Step 10.

10. Fuel vehicle to 3600 psi (24.6 MPa). **FIGURE 4–6.** Refer to fuel *Refer to ENP-516, Truck and Tractor CNG Fuel System Operation, Maintenance & Inspection Manual, “CNG System Fueling”* section.

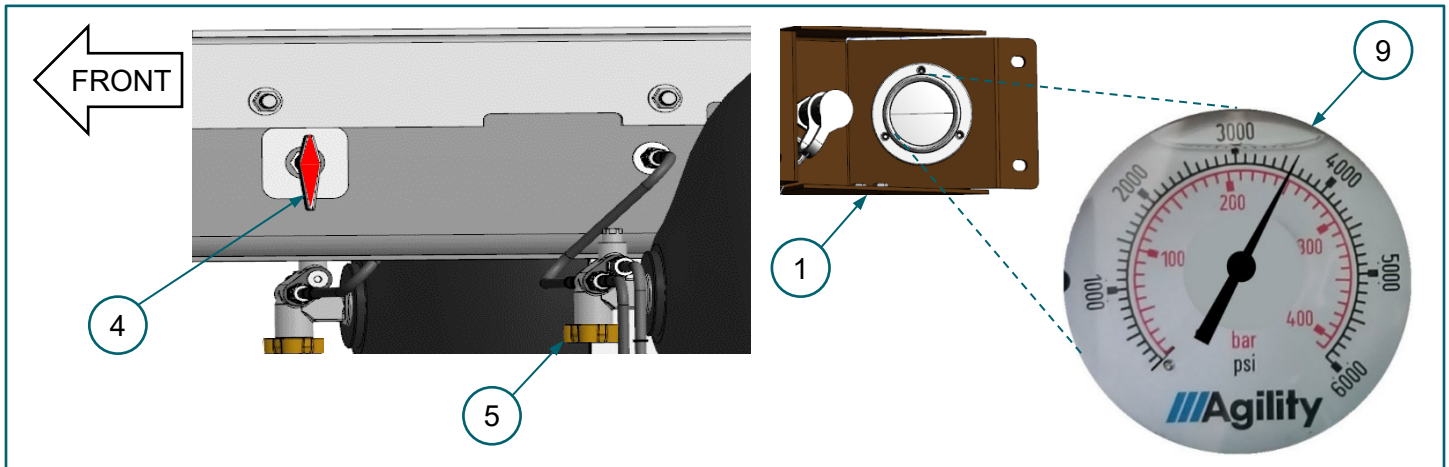

FIGURE 4–6. Fuel fill panel, (9) HP gauge reading 3600 psi, (4) 1/4-turn manual shutoff valve, (5) DS cylinder manual valve

11. Repeat Steps 6 through 7 until no leaks are present, then proceed to Step 12.

12. When the system passes the 3600 psi (24.6 MPa) leak test, use shop rags to clean all Swagelok® Snoop® from fuel system components.

13. Use a Torque Seal marker (*any color but yellow*) to mark properly tightened fuel system fittings and the bleed valve pressure relief nut. **FIGURE 4–7**

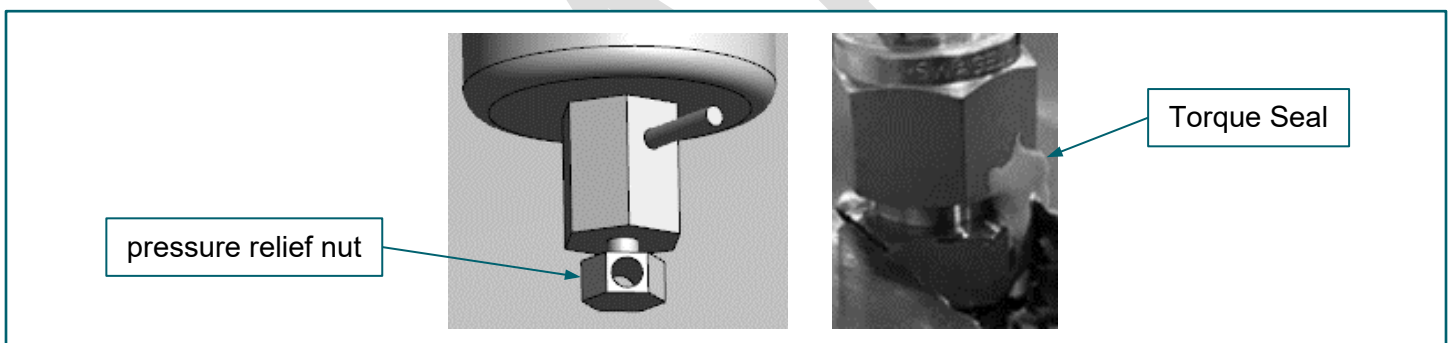

FIGURE 4–7. (8) bleed valve, pressure relief nut, fitting junction marked with Torque Seal

14. Install pressure relief port cap, p/n 61090128, and bleed valve cap, p/n 61090129, on (v) pressure relief port and (8) bleed valve. **FIGURE 4–8**

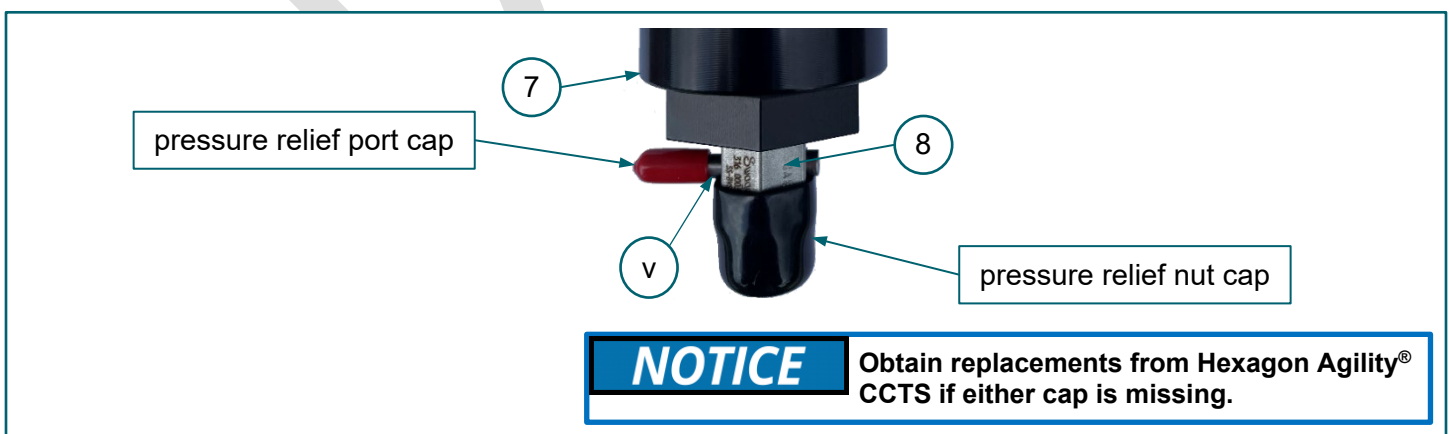

FIGURE 4–8. (7) HP fuel filter bowl, (8) bleed valve, (v) pressure relief port, pressure relief port cap, pressure relief nut cap

15. Road test vehicle using the procedure described below.

5. Road Test Procedure

1. Verify 1/4-turn manual shutoff valve, DS manual cylinder valve, and PS manual cylinder valve, are open.
FIGURE 5-1

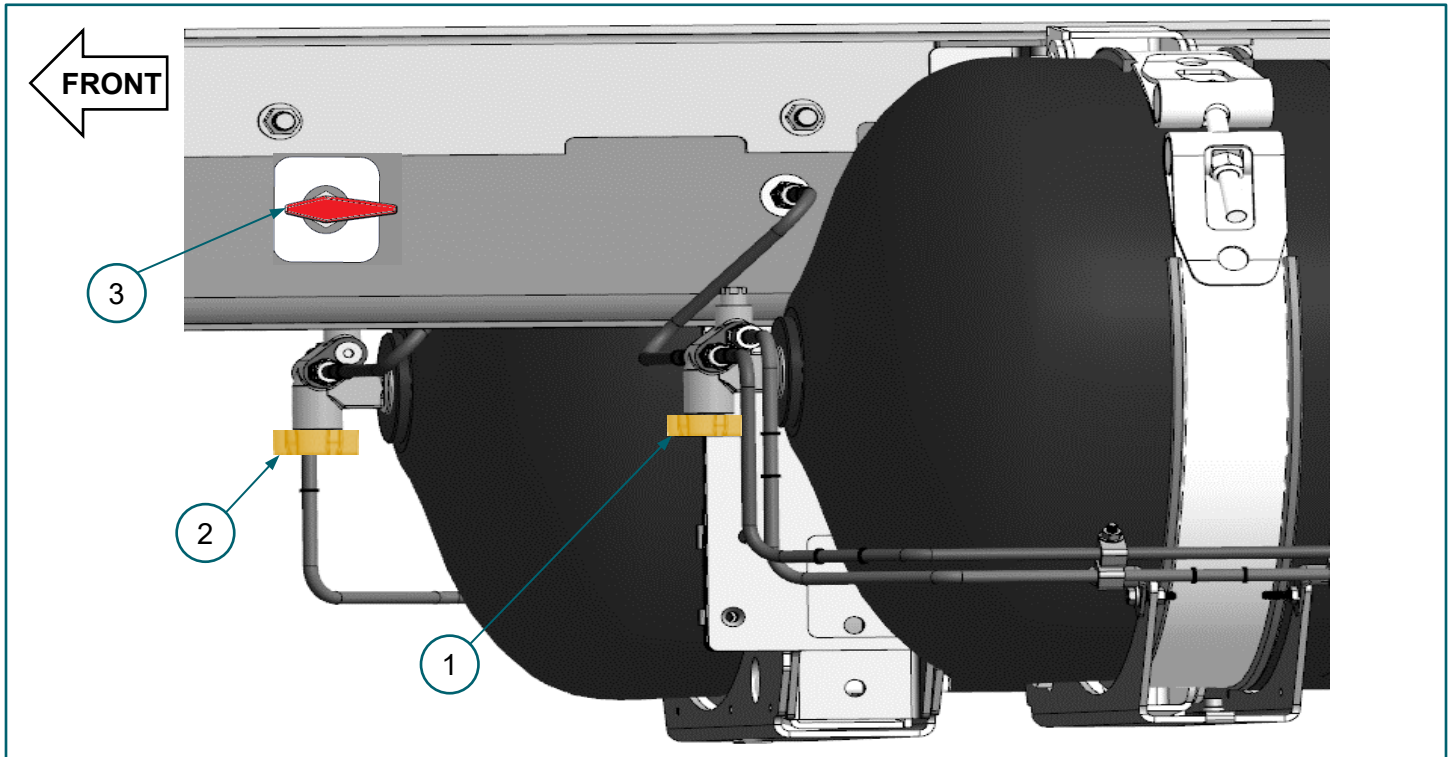

FIGURE 5-1. (1) DS manual cylinder valve, (2) PS manual cylinder valve, (3) 1/4-turn manual shutoff valve





2. Remove wheel chocks from front and rear of tires.
3. Start engine and verify proper fuel system operation.
4. Road test the vehicle until it reaches operating temperature.
5. **If a leak or system fault appears**, contact Hexagon Agility® CCTS.
6. If system is operating properly, release vehicle into service.
7. Update vehicle maintenance and repair records.

Appendix A. WI.0199 – Removal and Retightening of Tube Fittings

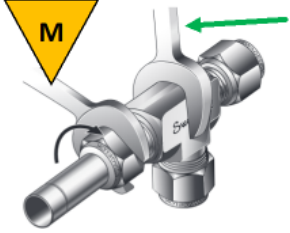

Removal and Retightening of Tube Fittings Scope: Swagelok fittings

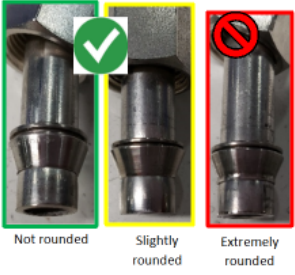
Standard Work Instruction

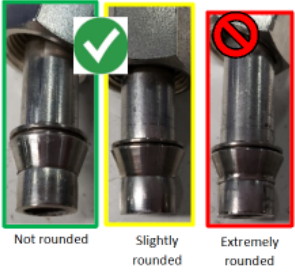
1	WHAT	Remove any torque seal using a non-marking scraper (such as a fingernail).		2	WHAT	Remove any torque seal and the blue paint pen marks from fitting and nut using a mild solvent (such as Isopropyl alcohol) on a cloth. Do NOT remove the DMT mark! BE CAREFUL WHEN HANDLING SOLVENTS.	
	WHY	New torque seal is needed when the fitting is retightened.			WHY	New blue marks are needed when the fitting is retightened.	
3	WHAT	Put a "backing wrench" on the body of the adjacent fitting. Note: some products require holding a different component - this is noted in the product-specific work instructions.		4	WHAT	Loosen nut and completely remove tube from fitting.	
	WHY	The backing wrench prevents the fitting from rotating. This ensures that no other fittings are accidentally loosened.			WHY		
5	WHAT	Inspect the front ferrule to verify that the tube can be reused. The front ferrule must not be rounded as the example highlighted in red. 		6	WHAT	To reinstall, follow the tightening sequence in WI.0198 . Note that there will likely be a gap between the DMT mark and the top of the nut when hand-tight.	
	WHY	When the front ferrule cannot spin freely, the back ferrule is pressed against it too much. This is caused by over-tightening.			WHY	Retightening causes the back ferrule to press further against the front ferrule, which shifts the nut position.	



Removal and Retightening of Tube Fittings
Scope: Swagelok fittings

Standard Work Instruction

Equipment List:

Description	Manufacturer	Manufacturer's Part Number
70% Isopropyl alcohol wipes	Any	---
Open-ended wrenches	Any	---
Vise	Any	---

Job Breakdown:

Important Steps	Key Points	Reasons Why
1. Remove torque seal	1. Completely removed	Must be replaced.
2. Remove paint marks	1. Completely removed	Need new visual aid to start tightening.
	2. Be safe	Solvents must be handled carefully.
	3. Don't remove DMT line	Provides reference for tightening.
3. Loosen nut	1. Use backing wrench	Holds everything in place to prevent leaks.
4. Check ferrule	1. Spins freely	A tight-fitting ferrule could leak.
5. Re-install nut	1. Per work instruction	Provides correct process

Hexagon Agility® Customer Care and Technical Services

Fuel system warranty or non-warranty product support may be obtained by calling or emailing Hexagon Agility® Customer Care and Technical Services (CCTS).

Please provide **your name, phone number, email address, and complete vehicle information: VIN, year, make, model, mileage, unit number vehicle owner, and current vehicle location.** A service advisor will contact you to arrange vehicle repair or ship a part.

+1 877 234 1722

(toll-free, U.S. and Canada)

UPS Direct Access Prompt: 6

Support

support@hexagonagility.com

Parts Orders

parts@hexagonagility.com

Proprietary Statement

The information provided within this document is proprietary and confidential. All prior versions, including updates and revisions forwarded separately, are proprietary. The information provided by Hexagon Agility® to its customers and clients is solely for the use of those customers and clients. No portion of this publication may be reproduced or distributed without express written consent of Hexagon Agility®. Hexagon Agility® reserves the right to utilize the intellectual property contained within this publication as content for any other publication produced by Hexagon Agility®.

Trademark Notice

Hexagon® is a registered trademark of Hexagon Technology AS. Agility® is a registered trademark of Agility Fuel Solutions LLC. Trademarks of other manufacturers are the property of their respective companies.

Hexagon Agility®

3335 Susan Street, Suite 100 Costa Mesa, CA 92626 USA

www.hexagonagility.com