

Technical product information

Topic	Bentayga - Air suspension warning light within the DIP - DTC's P089200 - C104707 - C103B13 - Evident within Address 74
Market area	Russische Föderation (5RU),Australia E04 Bentley rest Asia and Australia (6E04),China 796 VW Import Comp. Ltd (Vico), Beijing (6796),Germany E02 Bentley rest Europe (6E02),Japan E03 Bentley Japan (6E03),Korea, (South) E08 Bentley South Korea (6E08),United Arab Emirates E06 Bentley Middle East and Africa (6E06),United Kingdom E01 Bentley UK (6E01),United States E05 Bentley USA and rest America (6E05)
Brand	Bentley
Transaction No.	2062261/3
Level	EH
Status	Approval
Release date	

Event memory entries

Diagnostic address	Event memory entry	Fault type	Fault status
0074 - Chassis control	P089200: TCM Power Relay Sense Circuit Intermittent		Intermittent
0074 - Chassis control	P089200: TCM Power Relay Sense Circuit Intermittent		static
0074 - Chassis control	C103B13: Solenoid for level control system Open circuit		static
0074 - Chassis control	C103B13: Solenoid for level control system Open circuit		Intermittent
0074 - Chassis control	C104707: Level control valves mechanical malfunction		Intermittent
0074 - Chassis control	C104707: Level control valves mechanical malfunction		static

New customer code

Object of complaint	Complaint type	Position
running gear -> shock absorber/suspension control -> roll compensation	functionality -> defective function sequence	
lighting system, signalling -> sound signals -> acoustic warning for shock absorber/suspension control	functionality -> warning signal sounds without reason	
information, navigation, communication, entertainment -> symbolic control indicators -> warning lamp for electronic stabilisation programme (ESC)	functionality -> activates without reason	
information, navigation, communication, entertainment -> symbolic information indicators -> anti-roll bar decoupling indicator	functionality -> activates without reason	

New workshop code

Object of complaint	Complaint type	Position
electrical power, electric system, data transfer -> battery management -> de-energise	functionality -> cannot be activated	
electrical power, electric system, data transfer -> power supply -> high-voltage battery	electrics -> voltage too high	

Vehicle data

Bentayga

Sales types

Type	MY	Brand	Designation	Engine code	Gearbox code	Final drive code
4V1*	2017	E		*	*	*
4V1*	2018	E		*	*	*
4V1*	2019	E		*	*	*
4V1*	2020	E		*	*	*
4V1*	2021	E		*	*	*

Documents

Document name
master.xml

Customer statement / workshop findings

Customer statement:

Air suspension warning light within the DIP

Workshop findings:

One or a combination of the DTC's shown below are evident within address 74

- P089200 - Symptom Code 3145792 - TCM Power Relay Sense Circuit Intermittent (Level Control Valves Open Circuit)
- C103B13 - 3145909 - Solenoid for level control system Open circuit
- C104707 - 3211279 - Level control valves mechanical malfunction

Technical background

Refer to the Measure section of this TPI

Production change

.

Measure

1) Conduct a wiring integrity check between the (Valve block for adaptive suspension) NX7 to the (Running gear control unit - J775)

▪

Please note: The pin locations are different depending on Model Year as detailed within the onward instructions: 21 Model year

T81aa Pin 79 + T3er Pin 1

T81aa Pin 59 + T3er Pin 3

T81aa Pin 35 + T10as Pin 1

T81aa Pin 75 + T10as Pin 2

20 Model year

T81aa Pin 79 + T3cs Pin 1

T81aa Pin 59 + T3cs Pin 3

T81aa Pin 35 + T10ax Pin 1

T81aa Pin 75 + T10ax Pin 2

17 to 19 Model year

T81aa Pin 79 + T3dc Pin 1

T81aa Pin 59 + T3dc Pin 3

T81aa Pin 35 + T10ax Pin 1

T81aa Pin 75 + T10ax Pin 2

TIP: Previous instances have highlighted the following after inspection:

- Broken wires
- Kinked wiring
- Pin/s missing
- Pin/s broken
- Pin/s loose

2) Repair any broken or damaged wires as per Rep.Gr 97

▪

If the event that No fault is found with the integrity of the afore mentioned wiring circuits - Perform electrical integrity and visual inspections of the connectors

- Conduct a wiring integrity check between the Valve block for adaptive suspension control unit (NX7) and the Running gear control unit (J775)

NOTE: NX7 is located as shown in Figure 1 (On the air supply unit/opposite side to the valve block)

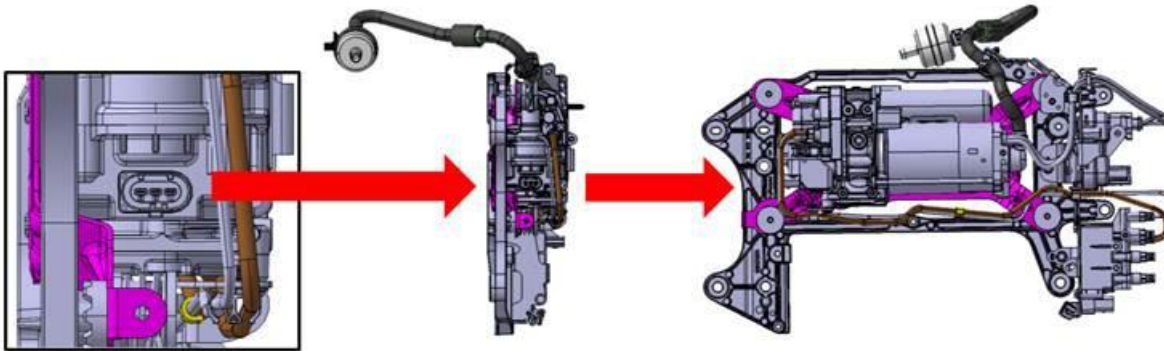

Figure 1

Should no issues be found regarding the integrity/visual checks please raise a new DISS query or respond to the previously opened DISS query

Warranty accounting instructions

Time to conduct wiring integrity checks

Warranty Type 110 or 910

Damage Service Number 4323

Damage Code 0015

Labour

Labour Operation Code 43130110

Time 80 TU

Wiring repairs

Labour

Labour Operation Code 97094152

Time 40 TU