

**SIB 34 03 13**

SERVICE ACTION: Hill Start Control - Bulletin 34 003 13 (034)

2021-09-09

This Service Information Bulletin replaces SI 34 003 13 (034) **dated December 2013**.

The contents of this bulletin have not changed; bulletin numbering was updated.

MODEL

This document applies to the following Motorrad AG models: 0612

This document applies to the following Motorrad model descriptions: K1600GTL US

This document applies to the following Motorrad series: K48

SITUATION

This document is applies to the following categories: Brakes

Supporting Materials

[picture_as_pdf 34_003_13_034_Hill_Start_Control.pdf](#)

Retail Operator General Manager	Sales New Motorcycles	Sales Pre-Owned Motorcycles	Business Manager (F&I)	Service	Parts & Accessories	Administration
Date: December 2013	Source: SI 31/2013					
Bulletin # 34 003 13 (034)	Name: Shawn McLean					
	Title: Service & Technical Manager					
	Phone: 201-307-4131					



BMW Motorrad USA

Service Information Bulletin

****Technical Campaign****

Subject: Hill Start Control

Model: K 1600 GT (K48, 0601 / 0611), K 1600 GTL (K48,0602 / 0612)

Details: Approximately 92 2014 K 1600 GT/GTL models were equipped from the factory with Hill Start Control. This function is not part of the Vehicle Order and is not described in the rider's manual for these motorcycles.

Vehicles affected: In order to determine if a specific vehicle is affected by this Technical Campaign, it will be necessary to verify all vehicle VINs through a DCS Vehicle History Check. Based on the response of the system, either proceed with the repair or take no further action. Please note, affected VINs may not appear until 24-72 hours after the release of this bulletin.

Production Solution: Motorcycles produced since August 28, 2013 have the correct software for the ABS control units, i.e. without Hill Start Control (integration level K001-13-08-510).

Aftersales Solution: For affected motorcycles that have not been handed over to retail customers, print a copy of the loose-leaf insert for the rider's manual (next page) and include it with the rider's manual at retail delivery. Be sure to fully explain the Hill Start Control option during the retail delivery process. For instances where the motorcycle has already been handed over to the customer, please make these customers aware of the situation as soon as possible (phone, email, etc) and encourage them to visit your dealership for a full explanation and demonstration of the function at the motorcycle. Also print a copy of the loose-leaf insert for the rider's manual and give the printout to the customer.

Warranty Information: The repair described in this bulletin is covered under warranty regardless of time or mileage.

Warranty: Defect code: 00 34 71 00 00 Information, Hill Start Control
Labor code: 00 60 280* Hill Start Control, 3 FRU

*Main Work 00 60 280 - this main labor operation crediting 3 FRUs includes all repair procedures to complete the task with allowance for necessary ancillary tasks (e.g., visual inspection, lubrication, cleaning parts etc.) and administrative tasks. Only one main labor operation can be claimed per repair visit. All other labor operations for any other line(s) must be claimed using plus code labor operations. Please refer to the Warranty Policy and Procedures Manual regarding add-ons, proper support, documentation, claims submission and archiving requirements as applicable.

Contact: Service and Technical Manager

Hill Start Control

– with Hill Start Control^{OE}

Hill Start Control is a pullaway assistant that operates on the partially integrated ABS system to prevent the vehicle from rolling back on a gradient without the rider having to keep pressure applied to the brake lever. When activated pressure is built up in the rear brake system to keep the machine at a standstill on a gradient. The holding pressure built up in the brake system depends on the steepness of the gradient.

⚠ Non-application of the brake by the Hill Start Control assistant if engine/ignition is switched off, side stand extended, a time limit exceeded (approx. 20 minutes) or in the event of a fault.

It is essential to apply the brakes manually to hold the vehicle.◀

▶ Hill Start Control is purely a comfort system to facilitate holding the machine and pulling way on uphill gradients and should not be confused with a parking brake. ◀

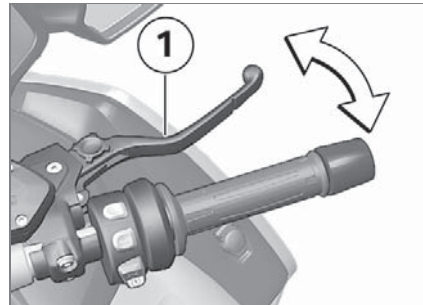

• Firmly pull and then release handbrake lever **1**.

(H) Telltale light for Hill Start Control appears in the display.

» Hill Start Control is activated.

• Pull handbrake lever **1** again to switch off Hill Start Control.

▶ Hill Start Control is deactivated automatically when the motorcycle pulls away.◀

• The 'General' warning light and the telltale light show briefly in the display and the telltale light for Hill Start Control goes out when the brakes are fully released.

» Hill Start Control is switched off.