



Mack Chassis - Equipped With A Cummins 9 Liter Engine - Serpentine Belt Excessively Worn Or Damaged; Fan Belt Shredding Or Fraying Repeatedly



> Internal Content

For a customer complaint regarding premature belt wear (fraying or shredding):

1. Replace the belt tensioner arm.

Note: Cummins also offers an additional, optional idler pulley kit to further minimize belt fatigue and noise. It is recommended that this kit be installed on vehicles used in time-critical applications. See part number below.

Part Information:

- Idler Kit, Cummins Part Number 5335096
- Belt - Refer to IMPACT

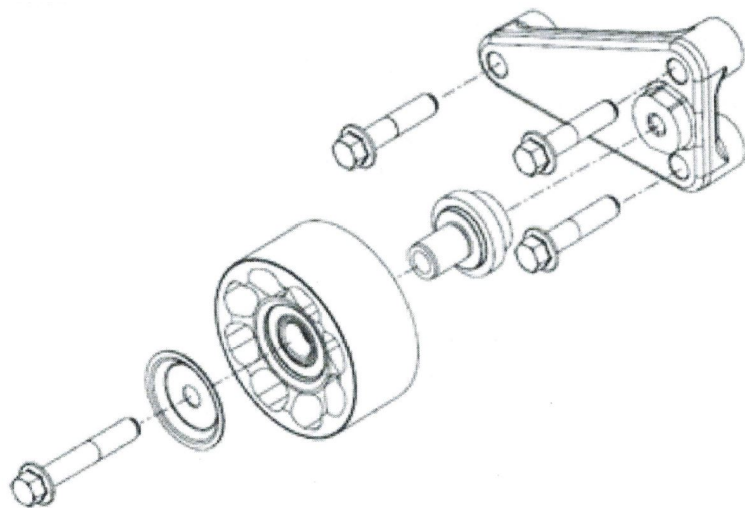

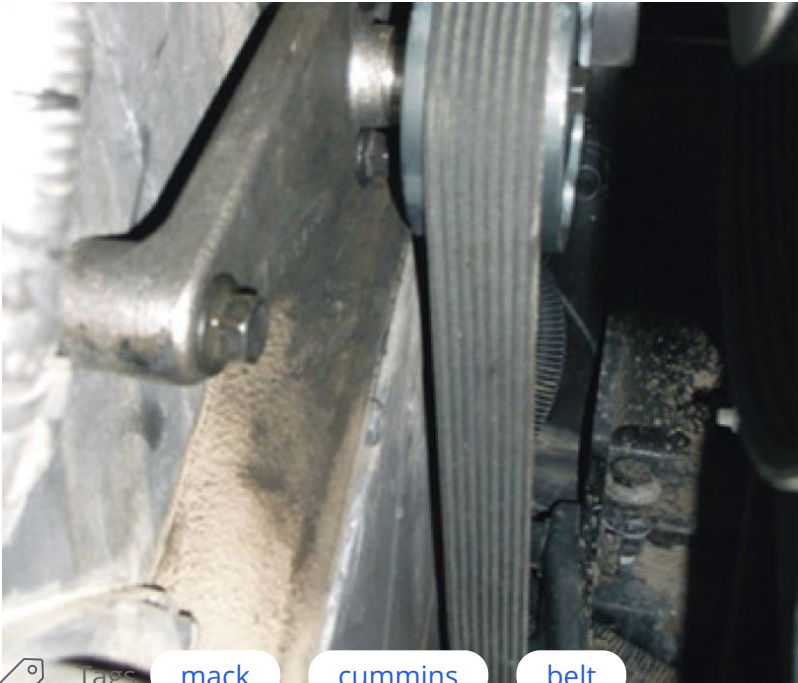

Tags

mack

cummins

belt

Related links and attachments

No links or attachments available



Feedback

[Give feedback](#)

to help improve the content of this article