



Volvo Chassis - Air Brake System Schematics And Routing VN, VHD Version 2, VT From Build Date 11.2011



> **Internal Content**

For more information refer to the Service Information - Air Brake Routing Schematics and Routing - [here](#).



Tags

[k39529632](#)

[volvo](#)

Related links and attachments

No links or attachments available



Feedback

[Give feedback](#)

to help improve the content of this article

Service Information

Volvo Trucks



Air Brake Routing Schematics and Routing

Group **56**
Release **01**

VN, VHD VERSION2
VT



Foreword

The descriptions and service procedures contained in this manual are based on designs and technical studies carried out through October 2013.

The products are under continuous development. Vehicles and components produced after the above date may therefore have different specifications and repair methods. When this is deemed to have a significant bearing on this manual, an updated version of this manual will be issued to cover the changes.

The new edition of this manual will update the changes.

In service procedures where the title incorporates an operation number, this is a reference to an V.S.T. (Volvo Standard Times).

Service procedures which do not include an operation number in the title are for general information and no reference is made to an V.S.T.

Each section of this manual contains specific safety information and warnings which must be reviewed before performing any procedure. If a printed copy of a procedure is made, be sure to also make a printed copy of the safety information and warnings that relate to that procedure. The following levels of observations, cautions and warnings are used in this Service Documentation:

Note: Indicates a procedure, practice, or condition that must be followed in order to have the vehicle or component function in the manner intended.

Caution: Indicates an unsafe practice where damage to the product could occur.

Warning: Indicates an unsafe practice where personal injury or severe damage to the product could occur.

Danger: Indicates an unsafe practice where serious personal injury or death could occur.

**Volvo Trucks North America, a division of Volvo Group North America,
Inc.**
Greensboro, NC USA

Order number: PV776-89096970

©2013 Volvo Group North America, Inc., Greensboro, NC USA

USA58397

General	1
About This Manual	1
Specifications	2
General.....	2
Air Tubing and Fittings.....	2
Tools	1
Special Tools.....	1
Design and Function	2
Air Brake System.....	2
General.....	3
Air Tubing and Fittings.....	3
Air Brake Routing Schematics.....	13
Brake Circuit Diagram.....	29

General

About This Manual

This manual is intended to give information for helping in troubleshooting the brake and air systems from point to point without having to trace the actual tubing. Shown is a particular circuit with its valves and actuators as located in the vehicle or schematics of the complete brake system.

This manual should be used together with Service Manuals *Air Brake Valves and Components* and *Compressors and Air Dryers* which describe each component in detail together with specifications, troubleshooting and test procedures.

Specifications

General

Type.....Compressed air brakes

Working pressure.....689 to 930 kPa (100 to 135 psi)

Variants:

4X2, tractor

4X2, truck

6X4, tractor

6X4, truck

Air Tubing and Fittings

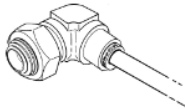

TUBING

Material.....Nylon (polyamide)

Standard.....SAE J844 & FMVSS 106

Sizes:

Unreinforced.....1/4 in. OD

Reinforced with fiber filament.....3/8, 1/2, 5/8 and 3/4 in. OD

Safety factor, minimum.....5.3:1

System working pressure, maximum.....1030 kPa (150 psi)

System working temperature range.....-40 to +90 °C (-40 to +200 °F)

FITTINGS

Type	End 1 Male Thread	End 2 PTC	Part number
Straight	1/8 NPTF	3/16	25088889
	M12x1,5 ISO 6149	1/4	20510630
	1/8 NPTF	1/4	8397718
	1/8 NPTF	3/8	8085303
	1/4 NPTF	1/4	8397719
	1/4 NPTF	3/8	8397720
	1/4 NPTF	1/2	8397721
	3/8 NPTF	1/4	8397722
	3/8 NPTF	3/8	8397723
	3/8 NPTF	1/2	8397724
	3/8 NPTF	5/8	8397725
	7/16 UNF45°	1/4	25166113
	1/2 NPTF	3/8	8397726
	1/2 NPTF	1/2	8397727
	1/2 NPTF	5/8	8397728
	1/2 NPTF	3/4	20864112
	5/8-18 UNF 45°	3/8	25168833
	3/4-16 UNF 45°	1/2	25166075
	7/8-14 UNF 45°	5/8	25168548
	M10x1,0	1/4	8397965
Straight, High Temp	M10x1,1	1/4	20566048
Straight	M12x1,5	1/4	8077358
Straight, High Temp	M12x1,6	1/4	20566049
Straight	M12x1,5	3/8	8397850
	M16x1,5	1/4	20448956
Straight, High Temp	M16x1,6	1/4	20566175
Straight	M16x1,5	3/8	20378448
	M16x1,5	1/2	20378446
	M16x1,6	5/8	None
	M22x1,5	1/2	20378447
	M22x1,5	5/8	20575880
	M22x1,5	3/4	20526020
45° Elbow	1/8 NPTF	1/4	8397709
	1/8 NPTF	3/8	8397710
	1/4 NPTF	1/4	8397711
	1/4 NPTF	3/8	8397712
	1/4 NPTF	1/2	8397713
	3/8 NPTF	3/8	8397714
	3/8 NPTF	1/2	8397715
	3/8 NPTF	5/8	8096194
	1/2 NPTF	3/8	8397716
	1/2 NPTF	1/2	8397717
	1/2 NPTF	5/8	8085662
	M16x1,5	3/8	21028654
	M16x1,5	1/2	21028655
	M22x1,5	1/2	21028656
	M22x1,5	5/8	21390071
	5/8-18 UNF 45°	3/8	20435696
	17/32 UNF 45°	3/8	20434046

Type	End 1 Male Thread	End 2 PTC	Part number
90° Elbow, Composite	3/8 Stem	3/8	20462708
90° Elbow	1/8 NPTF	1/4	8397697
90° Elbow, Swivel	1/8 NPTF	1/4	8397770
90° Elbow, Long Neck	1/8 NPTF	3/8	8081382
	1/8 NPTF	1/4	20377383
90° Elbow	1/8 NPTF	3/8	8084314
	1/4 NPTF	1/4	8397699
90° Elbow, Swivel	1/4 NPTF	1/4	8397771
90° Elbow	1/4 NPTF	3/8	8397700
90° Elbow, Swivel	1/4 NPTF	3/8	8397772
90° Elbow	1/4 NPTF	1/2	8397701
90° Elbow, Swivel	1/4 NPTF	1/2	8397773
90° Elbow	3/8 NPTF	1/4	8397702
90° Elbow, Swivel	3/8 NPTF	1/4	8397774
90° Elbow	3/8 NPTF	3/8	8397703
90° Elbow, Swivel	3/8 NPTF	3/8	8397775
90° Elbow	3/8 NPTF	1/2	8397704
90° Elbow, Swivel	3/8 NPTF	1/2	8397776
90° Elbow	3/8 NPTF	5/8	8397705
	1/2 NPTF	3/8	8397706
90° Elbow, Swivel	1/2 NPTF	3/8	8397777
90° Elbow	1/2 NPTF	1/2	8397707
90° Elbow, Swivel	1/2 NPTF	1/2	8397778
90° Elbow	1/2 NPTF	5/8	8397708
	1/2 NPTF	3/4	8076767
90° Elbow w/CV	1/2 NPTF	1/2	21116668
90° Elbow	M12x1,5	1/4	8082135
	M12x1,5	3/8	20378450
	M16x1,5	3/8	20414623
90° Elbow, Composite	M16x1,5	3/8	20999390
90° Elbow	M16x1,5	1/2	20515114
	M16x1,5	5/8	20469783
	M22x1,5	1/4	8082136
	M22x1,5	3/8	20551609
	M22x1,5	1/2	20462690
90° Elbow, Composite	M22x1,5	1/2	20999384
90° Elbow, w/CV	M22x1,5	1/2	20560349
90° Elbow, w/CV, Comp.	M22x1,5	1/2	20999392
90° Elbow	M22x1,5	5/8	20378449
90° Elbow, Composite	M22x1,5	5/8	20999385
90° Elbow, w/CV	M22x1,5	5/8	20462693

Type	End 1 Male Thread	End 2 PTC	Part number
90° Elbow	M22x1,5	3/4	20462691
90° Elbow, Composite	M22x1,5	3/4	20999388
Type	End 1	End 2	Part number
Straight, Composite	1/4 PTC	1/4 PTC	25155667
	3/8 Stem	1/4 PTC	25154458
Type	End 1 Female Thread	End 2	Part number
Straight	1/8 NPTF	1/4 PTC	25095244
	1/8 NPTF	3/8 PTC	25094466
	1/4 NPTF	3/8 PTC	25096429
	1/2 NPTF	3/8 PTC	25098182
	1/2 NPTF	1/2 PTC	25084769
90° Elbow	1/8 NPTF	1/4 PTC	25088709
	3/8 NPTF	1/4 PTC	25023728
	1/2 NPTF	1/2 PTC	25187407

Tools

Special Tools

The following special tools are required for fitting repair/replacement. The tool can be ordered from Volvo Trucks North America.



W0001874

J-44773

Airline Release Tool

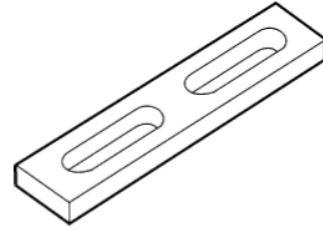

W0001873

J-44775

Valve Assembly Fixture

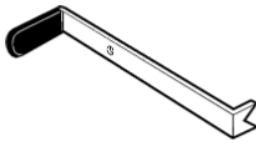

W0001198

J-42189

Tubing Release Tool

Design and Function

Air Brake System

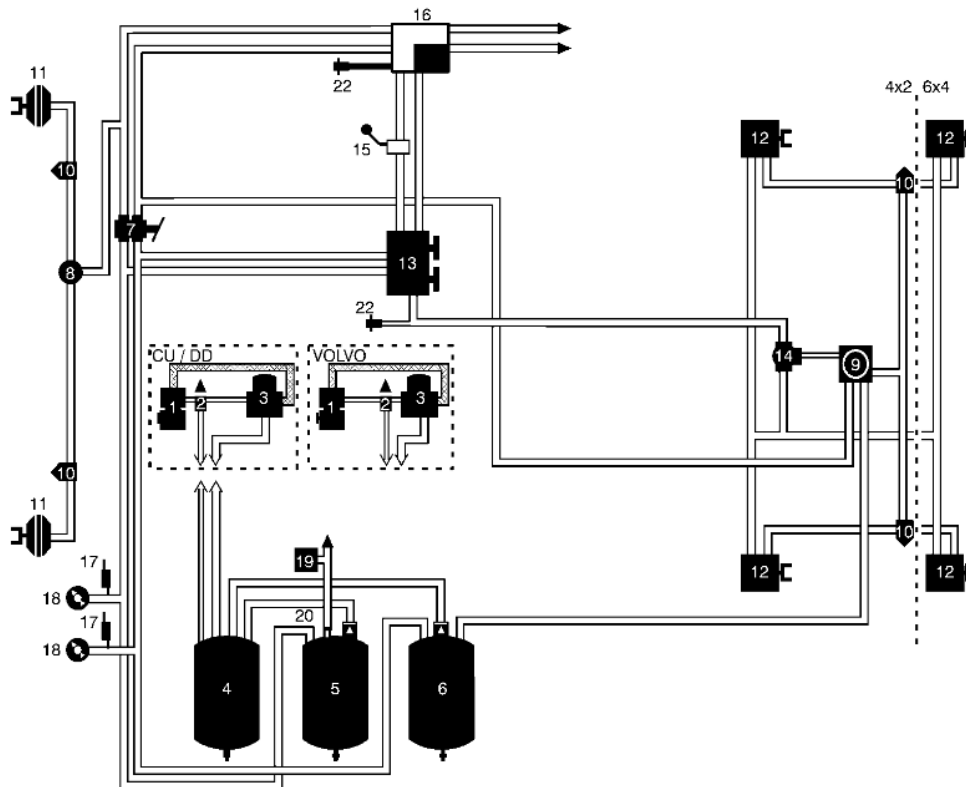

W5001599

- | | |
|--------------------------------------|---|
| 1 Compressor | 19 Accessory Manifold |
| 2 Governor; 2a Governor Servo Valve | 20 Pressure Protection Valve |
| 3 Coalescent Air dryer | 21 Parking/daytime Running Light Switch |
| 4 Wet Tank | 22 Stop Light Switch |
| 5 B System Tank | |
| 6 A System Tank | |
| 7 Foot Valve | |
| 8 Quick Release Valve | |
| 9 Relay Valve | |
| 10 ABS Modulator Valve | |
| 11 Spring Brake Chamber | |
| 12 Front Brake Chamber | |
| 13 Dash Manifold Valve | |
| 14 Quick Release Valve | |
| 15 Trailer Hand Brake Valve | |
| 16 Manifold Tractor Protection Valve | |
| 17 Low Air Pressure Switch | |
| 18 Air Pressure Gauge | |

General

The compressed air brake system is separated into two parts: a supply system and a control system. The supply system produces, stores and supplies compressed air to the various brake valves in the system and to any air powered accessories. The control system is on the downside of an operating valve. The valve is regulating the amount of air going to an actuator or other valve. Main operating valves are Foot Valve (7), Trailer Hand Brake Valve (15) and Manifold Dash Valve (13). They regulate air pressure going to the wheel brake chambers when operated. Other operating valves outside the brake system connect to the B system tank (5). A pressure protection valve (20) protects the brake system from draining, should a problem occur in an accessory supply line. A main supply line goes to the cab, supplying air to cab components, and to the accessory manifold (19), located in the frame, supplying air to chassis components. The circuit diagram above shows components for an ABS brake system. Components 9 and 10 change depending on application and vendor types. See Service Manual *Air Brake Valves and Components* for more information.

Air Tubing and Fittings

Shown is the brake system as a schematic layout or the actual routing in the vehicle on a 4x2 and a 6x4 vehicle or the brake system valves and tubing in separate circuits. All color on

tubing conforms to the standardized color scheme. This helps the identification and troubleshooting process with less possibility for mistakes.

Air Line Numbers and Description

2	Engine with mounting and equipment	Color	Line Size (inches)
21 Exhaust Brake			
21s01	Air Supply to Engine Exhaust Brake	Black	1/4
22 Fan Clutch			
22c01	Fan Clutch Control, Solenoid to Clutch	Green	1/4
22c02	Fan Clutch Solenoid Supply	Black	1/4
23 Air Cleaner			
23c01	Air Cleaner Intake Control	Purple	1/4
25 Emissions Control			
25s01	Diesel Particulate Filter Atomizer Block Supply	Red	1/2
25s02	DRV Valve Supply	Black	1/4
25s03	AHI Regulator Valve Supply	Tan	1/4
25d04	AHI Regulator Valve Delivery to Injector Air Pipe	White	1/4
3	Electrical Lighting and Instruments		
31 Switches			
31c01	Stop Light Switch Control	Black, Grey	1/4
31m02	Primary/Secondary Jumper	Grey	3/8
31m03	Hand Control Jumper	Grey	3/8

32 Gauges			
32m01	Rear Bellows Gauge Pressure	Purple	1/4
32m02	Front Bellows Gauge Pressure	Yellow	1/4
32m03	Primary Tank Pressure	Green	1/4
32m04	Secondary Tank Pressure	Red	1/4
32m05	Primary Brake Pressure	Green	1/4
32m06	Secondary Brake Pressure	Red	1/4
32m07	Rear Rear Bellows Pressure	Orange	1/4
32m08	ESP Rear Suspension Pressure	Purple	1/4
4 Power Transmission			
41 Clutch			
41s01	Clutch Release Air Assist Supply	Yellow	3/8
41c02	Neutral Switch	Red	1/4
42 Gearbox			
42s01	Gearbox Air Shift	Black	3/8, 1/2
42s07	Transmission Supply	Yellow, Black	3/8, 1/2
43 Rear Axle(s)			
43c01	Inter Axle Lock (Diff Axle)	Grey	1/4
43c02	Inner Wheel Lock (Diff Wheel)	Brown	1/4
44 Power Take-off (PTO)			
44d01	PTO Solenoid Delivery		1/4
44s02	PTO Solenoid Supply	Orange	1/4
5 Brake			
51 Compressor, Regulator, Anti-Freeze Unit			
51d01	Delivery from the Compressor		Hose
51m02	Air Dryer to Purge Tanks	Blue	3/8
51c03	Compressor Unload from Governor	Blue	1/4
51s04	Governor Supply from Wet Tank	Yellow	3/8
51d05	Air Dryer Delivery to Wet Tank	Blue	5/8
51c01	Air Dryer Purge Control from Governor	Blue	1/4
51s06	Schrader Valve Supply	Brown	1/4
52 Front Circuit			
52c01	Front Brake Valve to QRV/Tee (BSYS-CON)	Red	1/2
52c03	Redundant Rear Control	Brown	3/8
52c04	ESP Relay to ABS Modulator	Black	1/2
52d04	QRV/Relay to ABS Modulator (ABS Solenoid Valve)	Red	1/2
52d05	ABS Modulator to Brake Chamber	Rubber Hose	1/2
52s12	Front Circuit/ESP Relay Supply	Red	5/8

52s13	Front Circuit Foot Brake Valve Supply from Air Tank	Red	5/8
52m17	Foot Brake Valve to Front Circuit Pressure Sensor	Red	3/8
52d18	Tee to ABS mod LHS	Red	1/2
52d19	Tee to ABS mod RHS	Red	1/2
52d20	Foot valve to ESP ATC Valve/ESP Relay Control Port	Red	1/2
52s21	ESP ATC Valve Supply	Black	1/4, 1/2
52c22	ESP ATC Valve Control to Relay Control	Black	3/8
52s23	Foot Brake Valve to pass through Supply to Park Valve	Red	3/8
52m24	Foot Brake Valve to SLS DCV, Rigid Only	Grey	3/8
52c25	Hill Start Assist Inversion Valve Secondary Control from Treadle	Red	1/4
53 Rear Circuit			
53c01	Rear Service Relay Control from Treadle Valve	Green	3/8, 1/2
53c02	SBHC Control from Cab to Treadle DCV	Grey	1/4, 3/8
53c03	6S6M QRV Control from Rear Relay	Green	5/8
53d05	Anti-Compounding from Rear Relay	Green	3/8, 1/2
53d06	Relay to ABS Modulators (ABS Solenoid Valve)	Green	5/8
53d09	ABS Solenoid Valve to Brake Chambers (ABS)	Green, Rubber	5/8, Hose
53d10	Service Relay Valve to Brake Chambers (Without ABS)	Green, Rubber	5/8, Hose
53s11	Service Relay Supply from Air Tank	Green	3/4
53s12	Traction Control Supply from Park Valve Control	Green	1/4, 3/8
53s13	Treadle Valve Supply for Rear Circuit from Air Tank	Green	5/8
53m18	SBHC Jumper	Grey	3/8
53m19	SBHC Jumper 2	Grey	3/8
53m20	Treadle Valve to Rear Circuit Pressure Sensor (ESP)	Green	1/4
53m21	Treadle Valve to SLS DCV, Rigid Only	Green	1/4, 3/8
53s22	Treadle Valve to Pass Through Supply to Park Valve	Grey	3/8
53s23	Service Brake Hand Control Supply	Green	3/8
53s24	6S6M Rear Axle ABS Modulator Supply	Green	5/8
53s25	Hill Start Assist Supply	Blue	3/8
53c26	Hill Start Assist Control	Orange	1/4

54 Parking Brake			
54c01	Spring Brake Control	Orange	3/8
54d03	QRV/Relay Valve to Rear Spring Brake Chambers	Rubber	Hose
54d07	Joint Fitting at Rear Axle to LH Spring Brake Chamber	Rubber	Hose
54d08	Joint Fitting at Rear Axle to RH Spring Brake Chamber	Rubber	Hose
54s09	Inversion Relay Secondary Supply	Red	1/2
54s10	Inversion Relay Primary Supply	Blue	1/2
54m16	Park Control Exhaust from Dash Valve	Yellow	3/8
54c19	Redundant Control Line from Treadle Valve	Brown	3/8
54m20	Park Chamber Jumper Lines, Chambers Left to Right	Black	1/2
55 Trailer Brake			
55c01	Hand Control from Cab	Grey, Tan	3/8, 1/4
55c02	Spring Brake Control from Cab	Brown	3/8
55c03	Primary Control from Treadle Valve	Green, Orange	1/4, 1/2
55c04	Secondary Control from Treadle Valve	Red	3/8
55c05	EOFA Trailer Secondary Service Control from Relay	Blue	3/8, 1/2, 5/8
55c06	EOFA Trailer Park Control from Cab	Red	3/8
55m15	Hand Control Exhaust	Yellow	1/4
55c20	Trailer Park Control Tee to DFHC Inversion Control	Brown	3/8
55s22	Hand Control Tee to DFHC Inversion Supply	Grey	3/8
55s23	Control from ESP Trailer Modulator to Trailer Secondary Control	Red	3/8
55c24	Trailer Relay Control	Blue	3/8
55s25	Trailer Relay Supply	Red	1/2
55d26	Trailer Relay Delivery to TPV	Black	1/2
55c30	Spring Brake Control, Cab to Diverter Valve, TBCP-CFM	Brown	3/8
55c31	Spring Brake Control, Diverter to Cab TPV, TBCP, CFM	Brown	3/8
55c32	Spring Brake Control, Diverter to EOF TPV, TBCP-CFM	Brown	3/8
55c33	Treadle Valve to EOF TPV, Primary	Green	1/2
55c34	Treadle Valve to EOF TPV, Secondary	Red	3/8
55c35	Pedal Plate to EOF TPV, Hand Control	Grey	1/4
56 Hydraulic Retarder			
56s001	Manifold for Aux. Equipment to Retarder	Black	3/8

57 Air Tanks			
57s01	Primary Tank Supply	Black	1/2
57s02	Secondary Tank Supply	Black	1/2
57s03	Rear Primary Tank Supply	Green	5/8, 3/4
57s04	Auxiliary Axle Tank Supply	Red	1/2
57s05	Auxiliary Axle Tank Jumper	Green	5/8
57s06	Tag Axle Supply	Black	1/2, 5/8
57m07	Wet Tank Jumper	Black	1/2
57s08	Transmission Air Tank Supply	Red	1/2
57s09	Extra Air Tank Supply	Black	1/2
58 Auxiliary Axle			
58s01	Relay Supply	Red	3/8, 1/2, 5/8
58d02	1st Axle Relay to Bulkhead or Chambers	Red, Rubber	1/2, Hose
58d03	2nd Axle Relay to Bulkhead	Red	1/2
58d04	3rd Axle Relay to Bulkhead	Red	1/2
58c05	Primary/Secondary Control Checked	Green	1/4
58c06	Tag Axle Control	Green	3/8
58c07	Primary Control	Green	1/4
58c08	Secondary Control	Red	1/4
58d09	Quick Release to Bulkheads	Red	1/2
59 Auxiliary Equipment			
59s02	Auxiliary Manifold to Cab (for seat air)	Grey	1/4
6 Wheel, Suspension, Steering			
61 Auxiliary Axle Lift Control			
63s01	1st Axle Regulator Supply from Solenoid Pack	Orange	1/4
63s02	2nd Axle Regulator Supply from Solenoid Pack	Blue	1/4
63s03	3rd Axle Regular Supply from Solenoid Pack	Yellow	1/4
63c04	1st Axle Lift Bag Control to Control Valve	Purple	1/4
63c05	2nd Axle Lift Bag Control to Control Valve	Green	1/4
63c06	3rd Axle Lift Bag Control to Control Valve	Brown	1/4
62 Auxiliary Axle Mounted Controls			
64d01	Lift Bag Supply from Control Valve	Blue	1/2
64d02	Ride Bag Supply from Control Valve	Orange	1/2
64s03	Control Valve System Supply from Aux. Air Tank	Black	1/2
7 Frames, Springs, Damping and Wheels			
72 Air Suspension Rear Axle(s)			

72s01	Leveling Valve Supply from PPVM	Black	3/8
72d02	Air Bellow Pressure from Tee to Cab	Purple	3/8
72c03	Rear Suspension Dump from Solenoid Pack	Black	1/4
72d04	Front Rear Bellows Pressure 6x2 to Cab	Purple	3/8
72d05	Rear Rear Bellows Pressure 6x2 to Cab	Orange	3/8
72d11	Front Bellows to Rear Bellows	Blue	3/8
73 Air Suspension Front Axle(s)			
73s01	Leveling Valve Supply from PPVM	Black	1/4
73d02	Air Bellow Pressure (left) from Leveling Valve	Yellow	1/4
73d08	Air Bellow Pressure (left) from Tee to Cab	Yellow	1/4
8 Cab			
81 Cab Suspension			
81s02	PPV Manifold to Cab Leveling Valve, Rear	Green	1/4
81d05	Cab Leveling Valve (rear) to Rear Bellows LHS	Black	1/4
81d06	Cab Leveling Valve (rear) to Rear Bellows RHS	Black	1/4
82 Seat Suspension			
82s01	Seat Suspension Supply form PPVM	Brown	1/4
83 Air Horn			
83s01	Solenoid Valve Pack to Air Horn	Red	1/4
83d03	Auxiliary Manifold to Air Horn Lanyard Valve	Black	1/4
9 Miscellaneous, Special Functions			
91 Fifth Wheel			
91c01	5th Wheel Slide from Solenoid Pack	Yellow	1/4
91c02	Touch Release Park Signal from Rear Park Control Tee	Orange	1/4
91d03	Touch Release Piston Control from 2nd Solenoid	Grey	3/8
91c04	Inversion Supply from 1st Solenoid	Blue	1/4
91m05	2nd Solenoid Jumper from Inversion Valve	Blue	3/8
91d06	Touch Release Control from 2nd Solenoid to 5th Wheel	Grey	3/8
93 Miscellaneous			
93s01	Solenoid Valve Pack Supply from PPVM	Orange	3/8
93s02	PPV Manifold Supply from Secondary Air Tank	Red	1/2
10 Miscellaneous, Inside Cab			
R2BK	Secondary Tank Supply, Cab Pass Through to Dash Valve	Red	3/8
R1AK	Primary Tank Supply, Cab Pass Through to Dash Valve	Green	3/8

R1AK/53S23	Supply to Hand Control Valve from Cab Pass Through	Green	3/8
DLE3	Delivery from Hand Control Valve to Cab Pass Through	Grey	3/8
T1C3	Dash Valve Delivery to Cab Pass Through, Trailer Spring Brake Control	Brown	3/8
TRPK	Dash Valve Delivery to Cab Pass Through, Trailer Spring Brake Control	Orange	3/8

All tubing is made of nylon and sizes are always measured as an outer diameter (OD). The 1/4 in. tubing is a solid core, single ply extrusion. All other sizes are made of a solid core, covered with a protective, colored layer with fiber reinforcement between the layers. The cover is treated for heat and sunlight resistance.

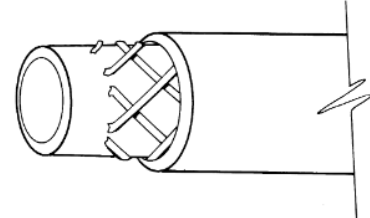

W5000379

In areas where great flexibility is needed, air is routed in rubber hoses, for example, between frame and the axles. A hose is built up of three layers of rubber and reinforcement. Hoses are specifically made for each installation to the correct length with crimped on fittings on either end.

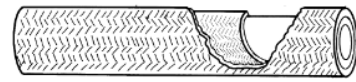

W5000384

Fittings are typically of the push-connect type. To connect or disconnect tubing is very easy, which simplifies troubleshooting in the air system. New, simple test gauges have been introduced for testing the valves and pressures (See Service Manual: *Air Valves and Components*).

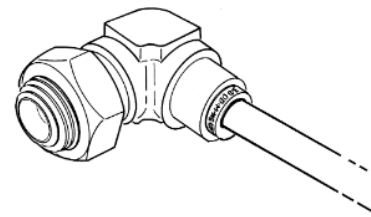

W5000377

The fitting body is made of brass. An internal O-ring seals on the outside diameter of the tubing and the retaining collar holds the tubing firmly in place. Straight fittings have an internal hex

grip, most others have external hex grip. A number of valves also come with push-type connectors already installed in the valve body.

The fitting is designed for letting the tubing rotate to eliminate kinks. The fitting IS NOT designed for locations with continuous movement, such as, between frame and axle. Threads are pre-applied with sealant. A fitting can be reused in the same port up to five times before new sealant needs to be applied.

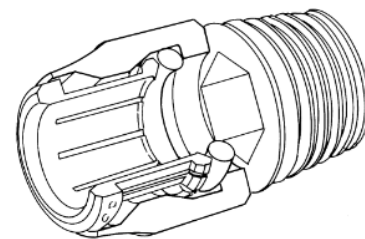

W5000378

Air Tubing Installation

To ensure a tight seal between tubing and fitting, the tubing end needs to be cut straight. Also, inspect tubing that has been removed for "teethmarks" around the perimeter where the retaining collar holds the tubing in place. If the marks are too deep, that is, can be easily seen or a depression can be felt by running a fingernail across mark, recut the tubing before reinstalling.

Installing is done by aligning tubing in a straight line with the fitting opening. Push until the tubing stops against the bottom of the fitting.

When the tubing has bottomed in the fitting, pull back to make the collar retaining teeth engage the tubing. Do not pull too hard, only enough to ensure that the collar has gripped the tubing.

Air Tubing Removal

To make removal easier, remove tubing when valve or component is still in place.

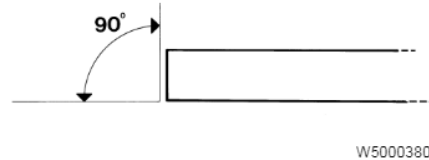

W5000380



W5000381

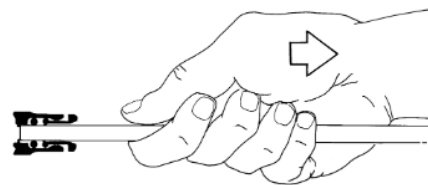

W5000382

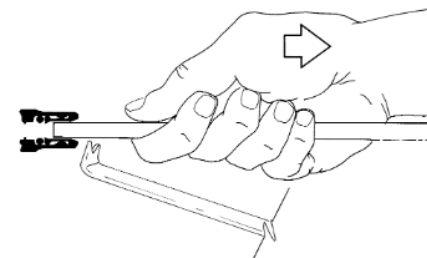

W5000580



WARNING

Always make sure that all compressed air is removed from the air system before removing tubing or components. Compressed air has great force and can create serious personal injury.

To disconnect, push the tubing into the fitting until it bottoms. Use release tool J42189 to push in the collar and then pull out tubing while holding the collar in.

Push-In Fitting Assortment Repair Kit

The Push-In Fitting Assortment Repair Kit (PN 85108461) contains replacement O-rings and collets for the most popular Fleet-Fit and Compact Cartridge Fittings found throughout

Volvo's air brake system, as well as the tools necessary to effectively complete a repair.

Assembly with Fleetfit Collet

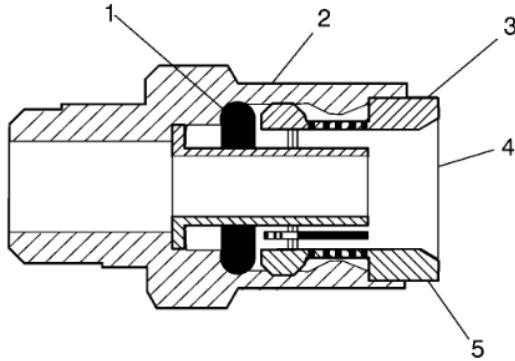

Assembly with Compact Collet

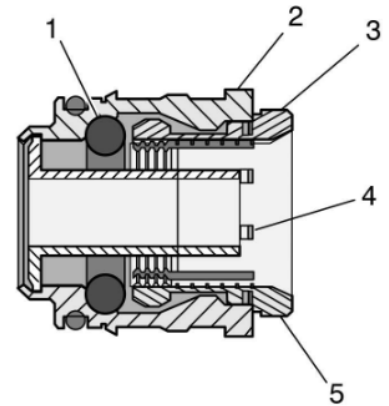

W5

- 1 Low nitrite O-ring
- 2 Brass adaptor
- 3 Multi-tooth Fleetfit collet
- 4 Rigid tube support
- 5 Tube O/D marked on collet head

- 1 Low nitrite O-ring
- 2 Brass cartridge
- 3 Multi-tooth Fleetfit collet
- 4 Rigid tube support
- 5 Tube O/D marked on collet head

Note: For tools needed to complete the repair/replacement, see "Special Tools", page 1

Air Tubing Repair

In the event that tubing has been severed as the result of an accident or if tubing needs to be lengthened for rerouting, there are certain procedures that must be followed.

In general, there are no restrictions against repairing tubing versus replacing it. A repaired tubing has the same integrity as the rest of the system if the repairs are done properly. Tube to tube fittings are available for 1/4, 3/8 and 1/2 in. tubing.

Damage to one tube is repaired so that the repair fitting is close to a bracket for support. Prepare the tubing as outlined on the previous page. Push the tubing ends into the fitting. Leak test fitting at full pressure after system pressure has been established again.

If a whole bundle of tubing needs to be repaired or lengthened, make sure the fittings are staggered instead of installed at the same length. Put the larger fittings close to a bracket for support and the smaller fittings further away.

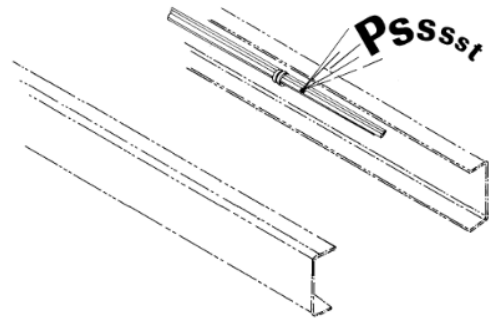

W5000582

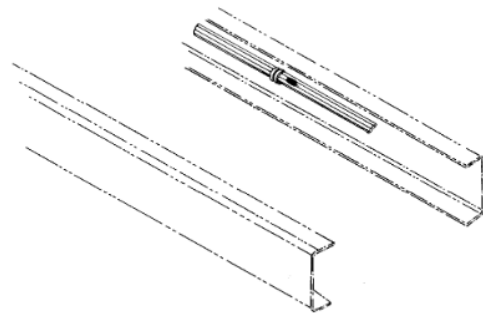

W5000583

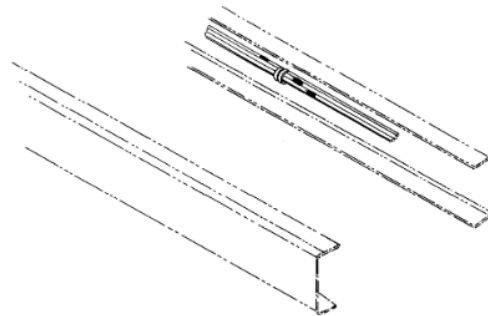

W5000584

Air Brake Routing Schematics

Front Brake Valves

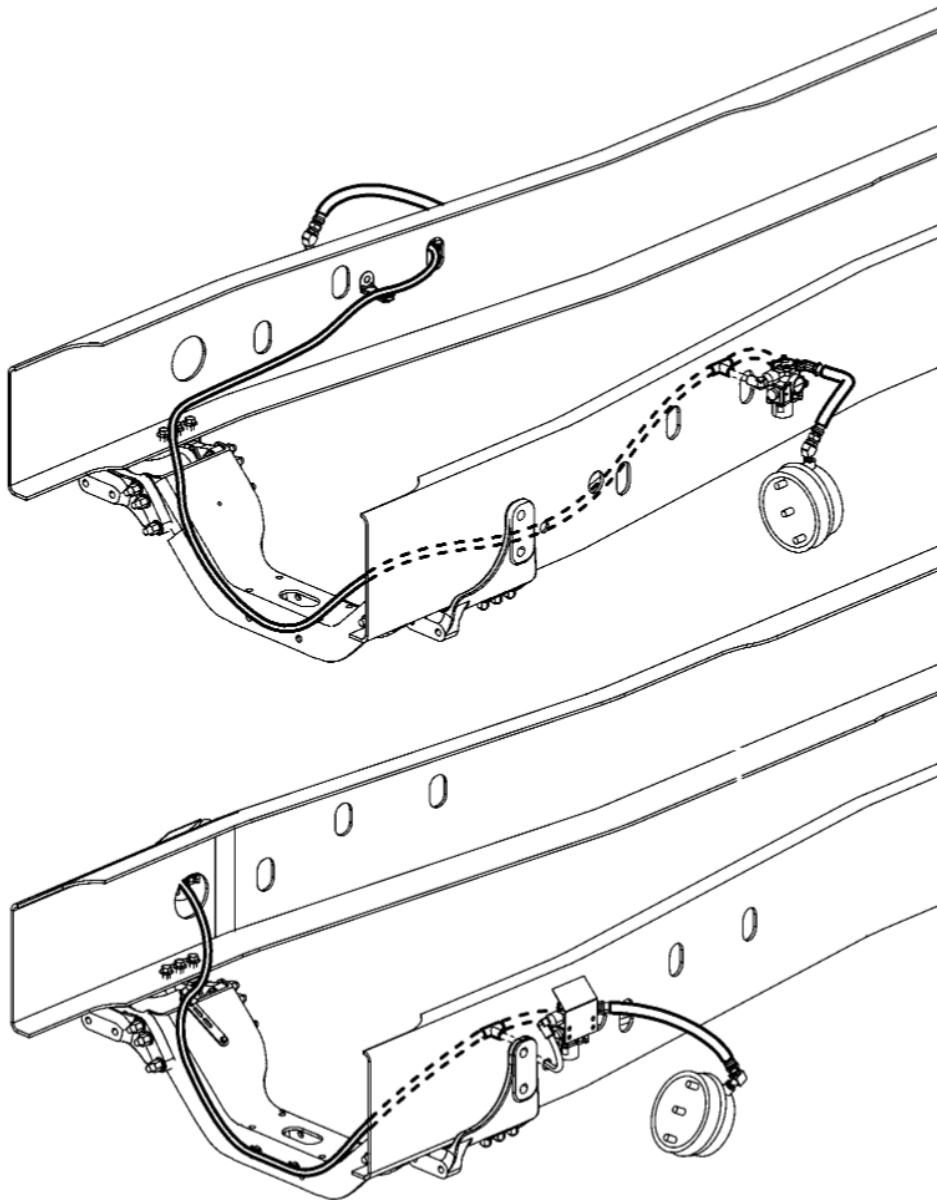

W5001600

See "Bulkhead", page 14.

See "Front Section, Battery Box, LH Side Behind Front Fender", page 15.

See "Front Section, Battery Box, LH Side Behind Fuel Tank", page 16.

See "Hill Start Assist Valves", page 18.

To Governor.

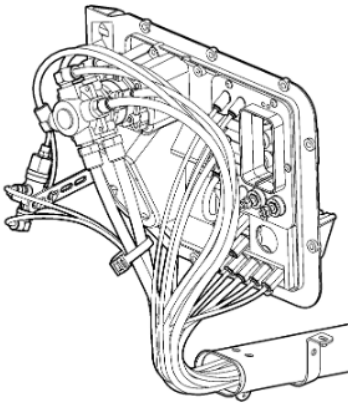
Bulkhead

W5001619

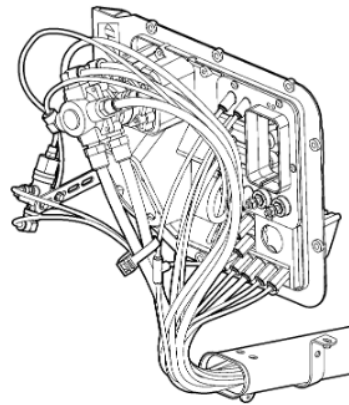

W5001620

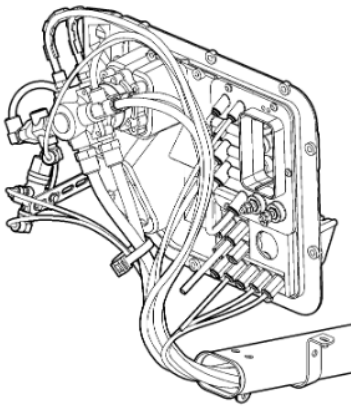

W5001621

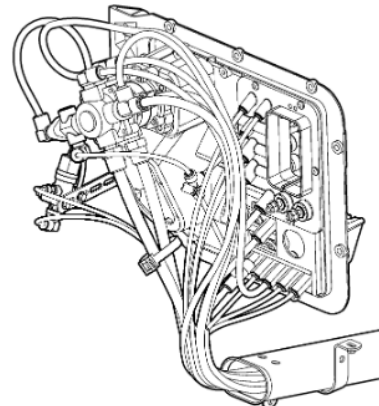

W5001622

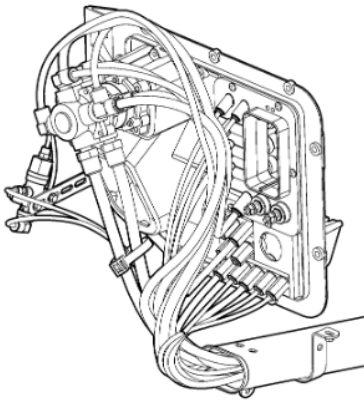

W5001623

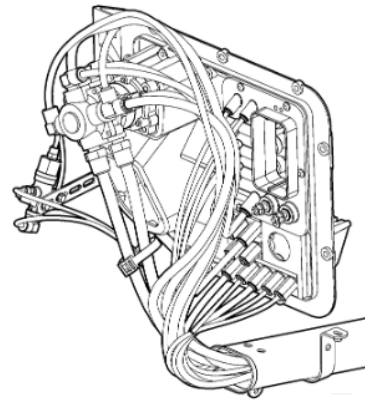

W5001624

See "Front Section, Battery Box, LH Side Behind Front Fender", page 15.

See "Front Section, Battery Box, LH Side Behind Fuel Tank", page 16.

See "Hill Start Assist Valves", page 18.

Front Section, Battery Box, LH Side Behind Front Fender

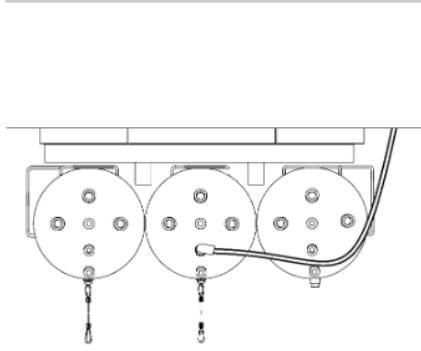

W5001630

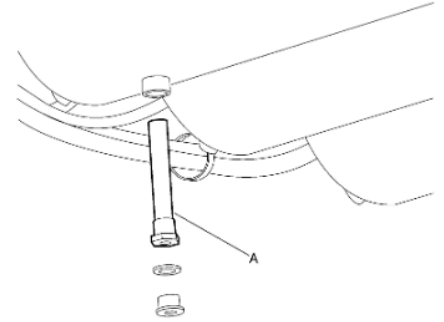

W5001648

A Internal automatic drain valve

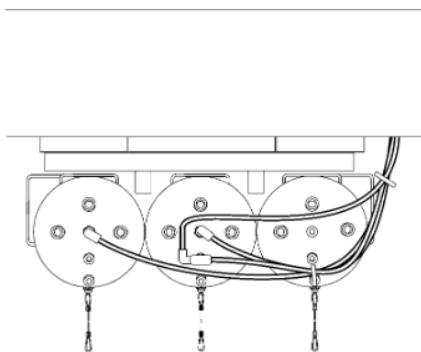

W5001631

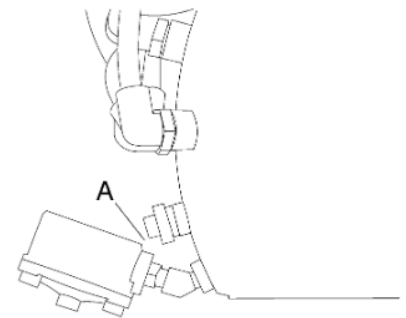

W5001647

A External automatic drain valve

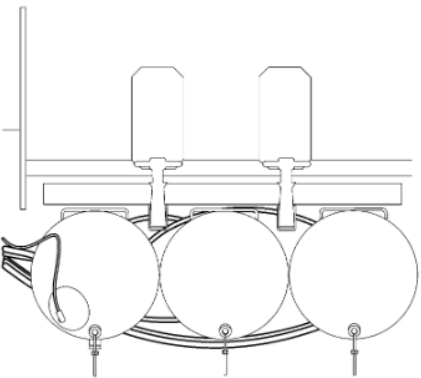

W5001632

See "Bulkhead", page 14.

See "Front Brake Valves", page 13.

See "Middle Section, No Pusher", page 24.

See "Middle Section, Three Rear Axles (One Pusher) or Two Rear Axles (One Pusher)", page 22.

See "Middle Section, Four Rear Axles (Two Pushers)", page 21.

See "Middle Section, Five Rear Axles (Three Pushers)", page 20.

Front Section, Battery Box, LH Side Behind Fuel Tank

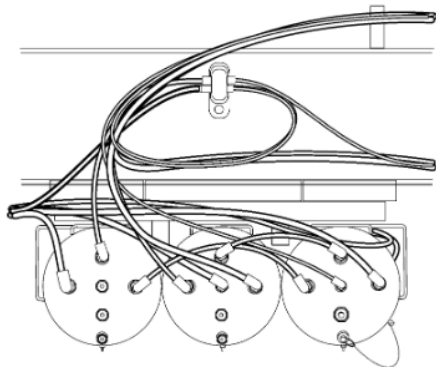

W5001625

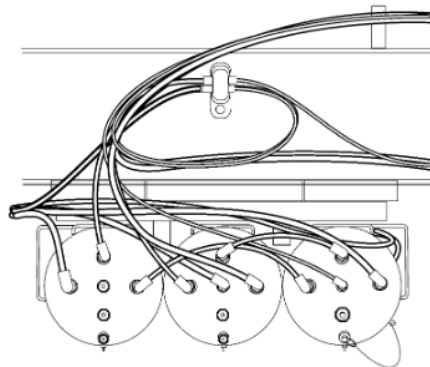

W5001628

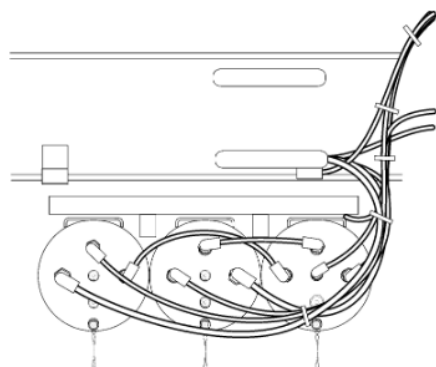

W5001626

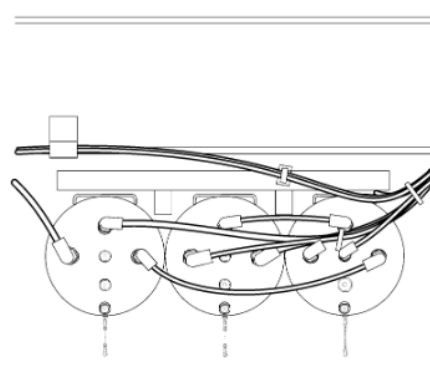

W5001629

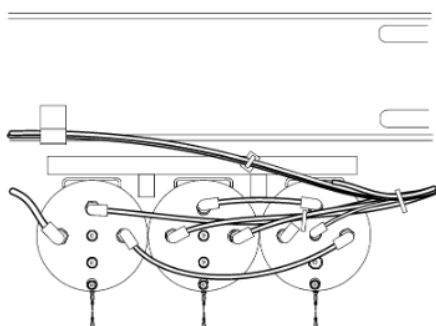

W5001627

See "Bulkhead", page 14.

See "Front Brake Valves", page 13.

See "Middle Section, No Pusher", page 24.

See "Middle Section, Three Rear Axles (One Pusher) or Two Rear Axles (One Pusher)", page 22.

See "Middle Section, Four Rear Axles (Two Pushers)", page 21.

See "Middle Section, Five Rear Axles (Three Pushers)", page 20.

Air Tank Mounting — VHD

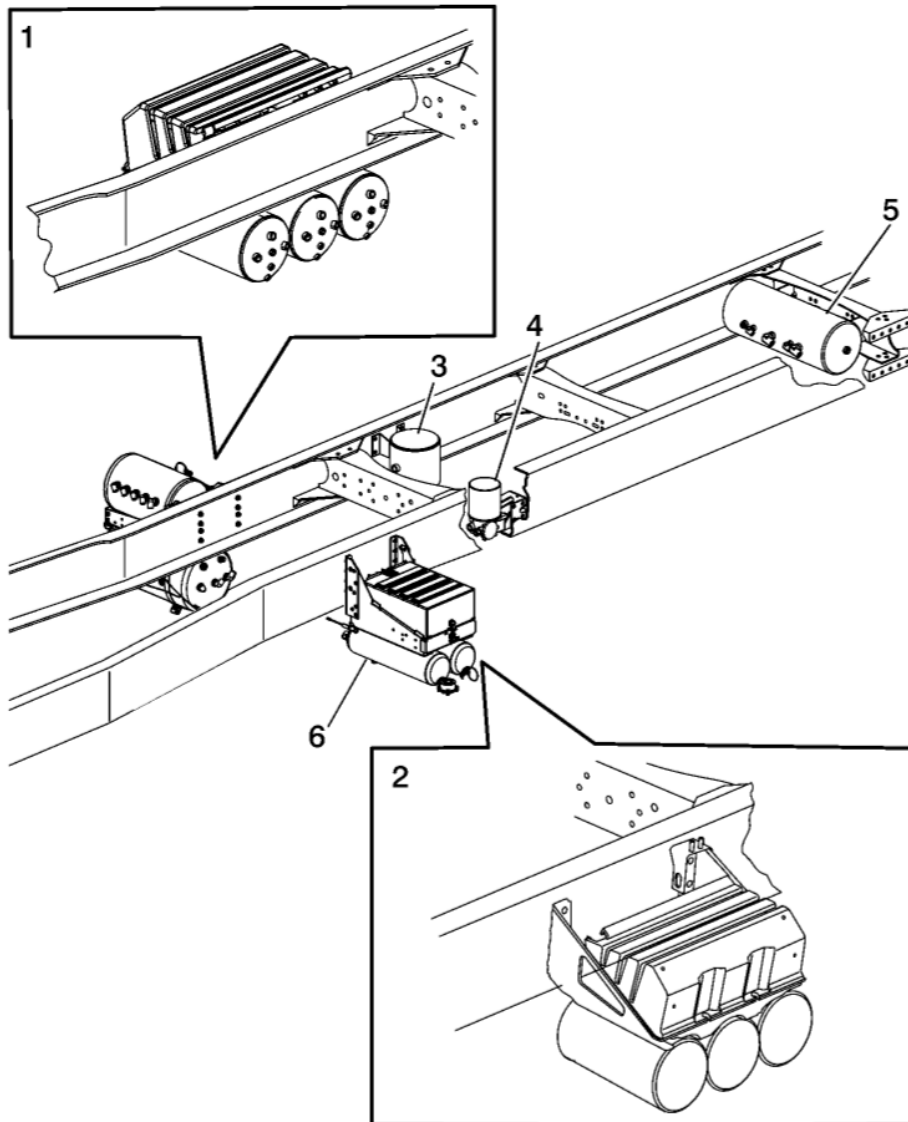

W5001645

- 1 VHD – Right Side frame rail Option
- 2 VHD – Left Side frame rail
- 3 Purge Tank
- 4 Air Dryer VHD
- 5 Crossmember Mounted VHD
- 6 Two air tanks under battery box, both for Wet volume, VHD

Hill Start Assist Valves

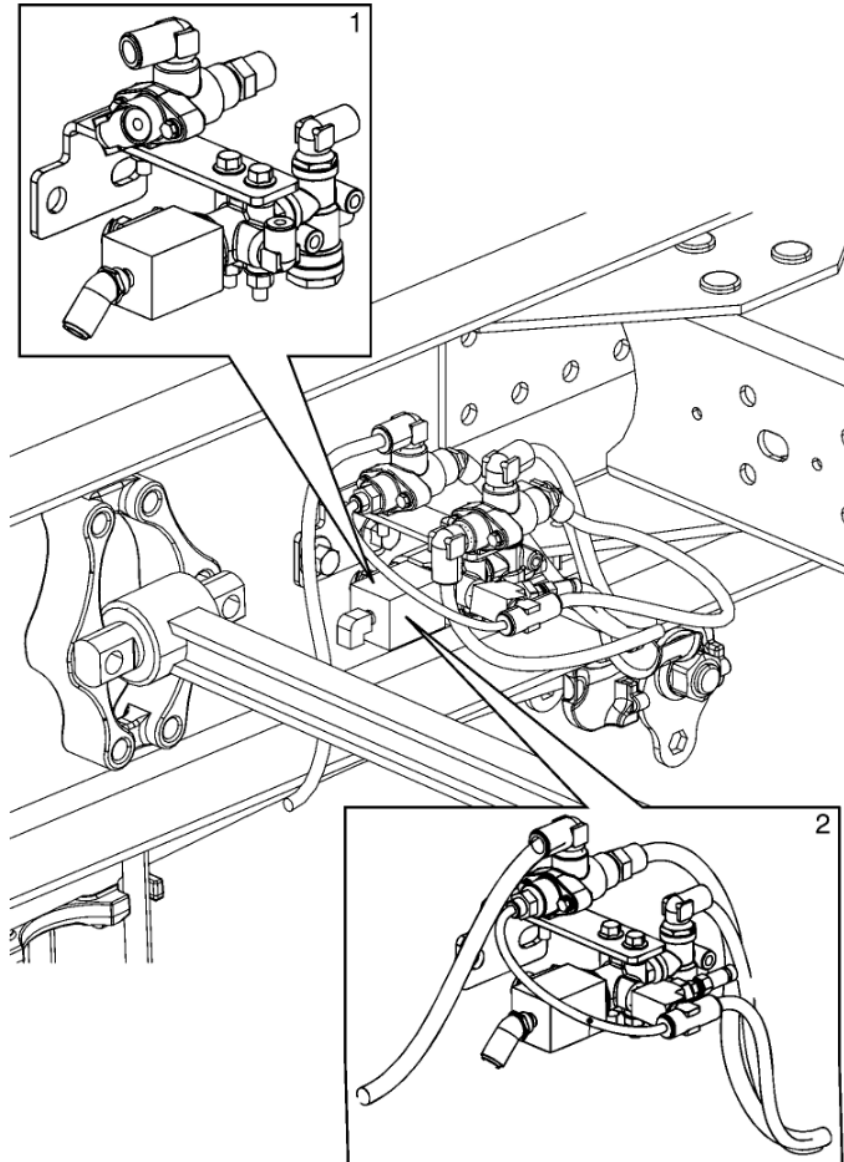

W5028441

1 Plain Rigid

2 Tractor with no Trailer Hand Control Valve

See "Bulkhead", page 14.

See "Front Brake Valves", page 13.

See "Middle Section, No Pusher", page 24.

See "Middle Section, Three Rear Axles (One Pusher) or Two Rear Axles (One Pusher)", page 22.

See "Middle Section, Four Rear Axles (Two Pushers)", page 21.

See "Middle Section, Five Rear Axles (Three Pushers)", page 20.

Battery Box, LH Forward with DPF under cab

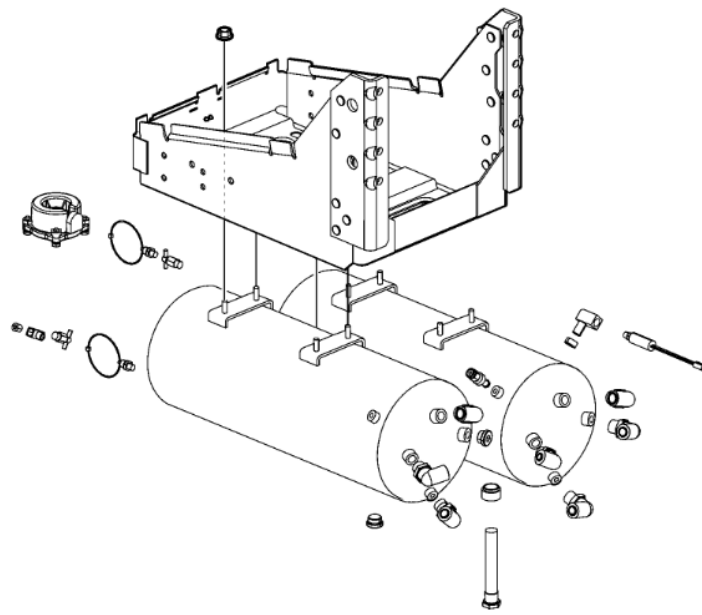

W5001601

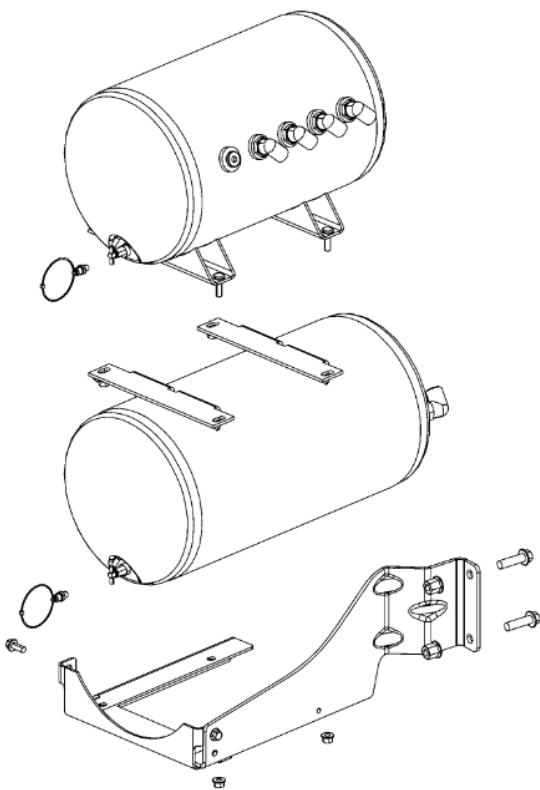

W5001635

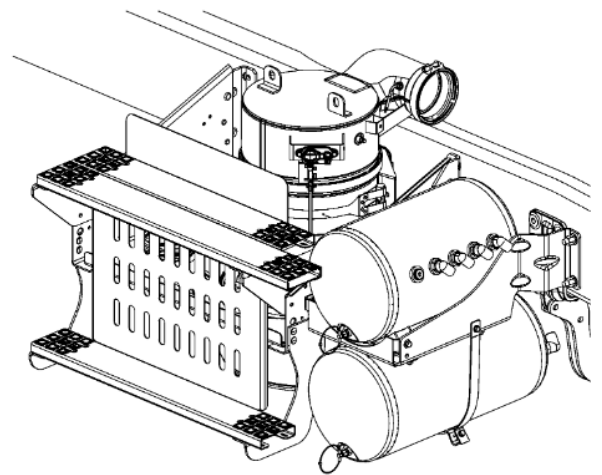

W5001636

Middle Section, Five Rear Axles (Three Pushers)

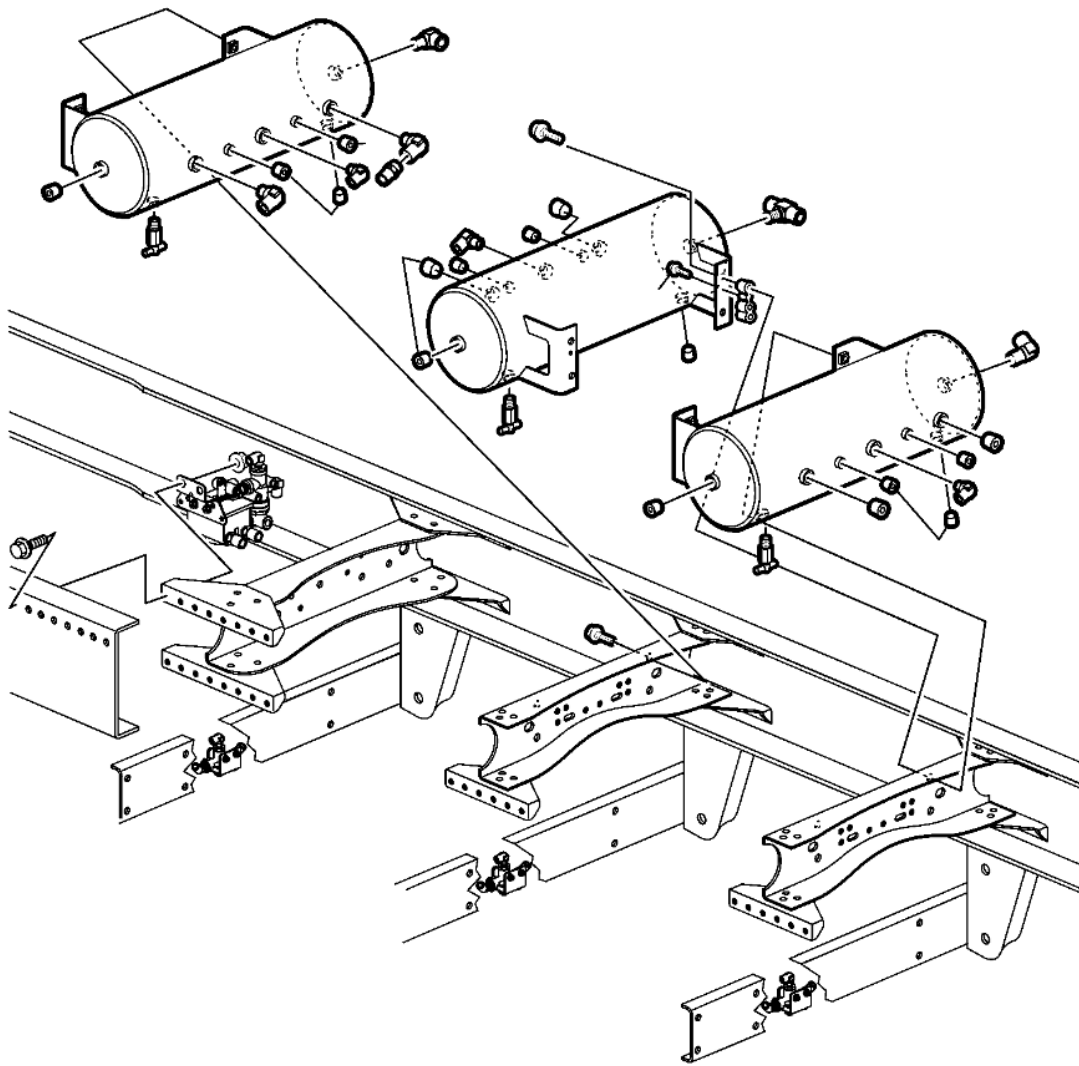

W5001638

See "Front Section, Battery Box, LH Side Behind Front Fender", page 15.

See "Front Section, Battery Box, LH Side Behind Fuel Tank", page 16.

See "Hill Start Assist Valves", page 18.

See "B Ride Suspension (Up to 46K)", page 25.

See "Hendrickson Suspension", page 28.

See "Hendrickson HN/RT Suspension", page 27.

Middle Section, Four Rear Axles (Two Pushers)

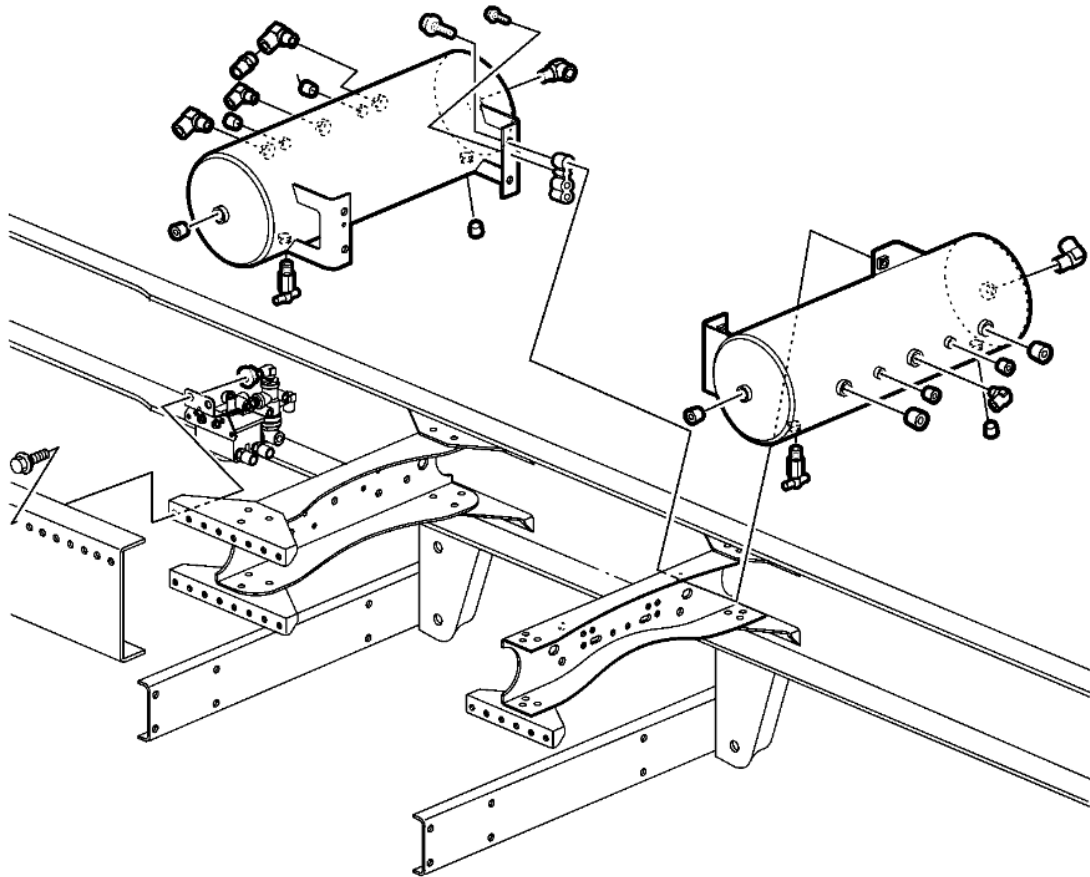

W5001639

See "Front Section, Battery Box, LH Side Behind Front Fender", page 15.

See "Front Section, Battery Box, LH Side Behind Fuel Tank", page 16.

See "Hill Start Assist Valves", page 18.

See "B Ride Suspension (Up to 46K)", page 25.

See "Hendrickson Suspension", page 28.

See "Hendrickson HN/RT Suspension", page 27.

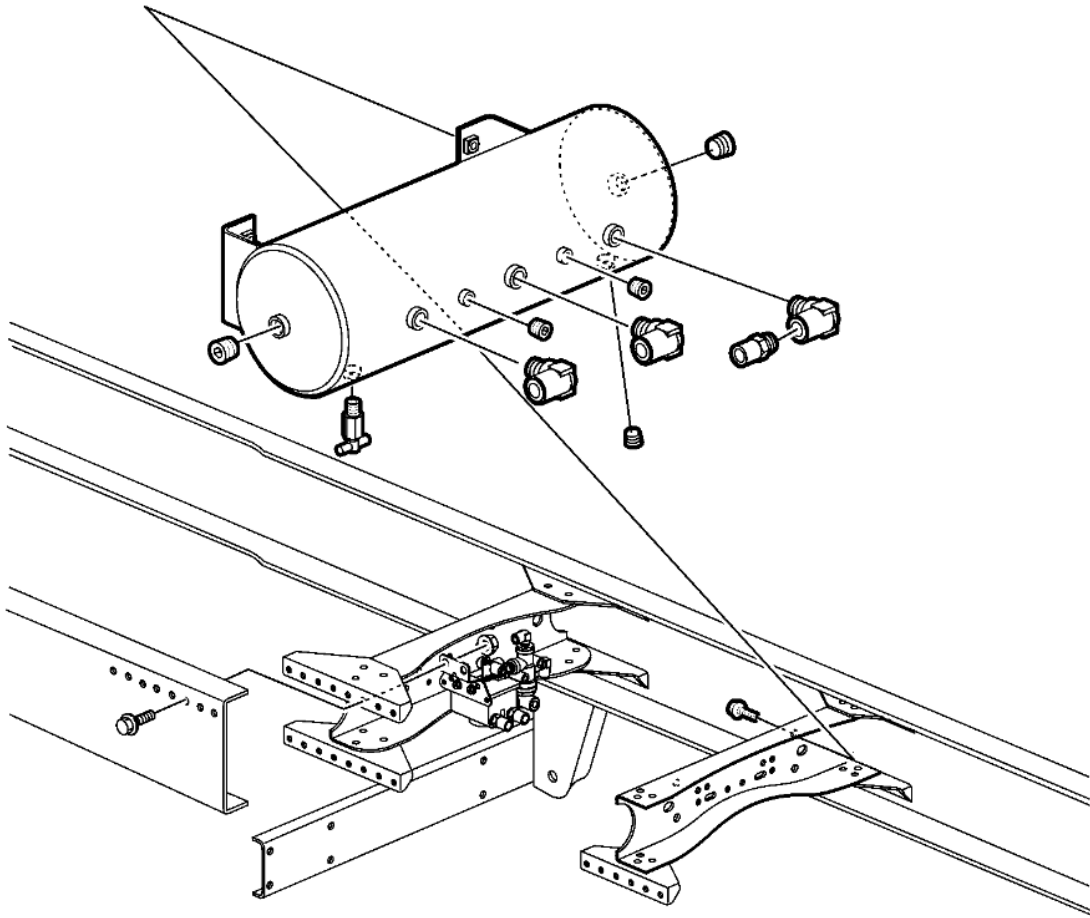
Middle Section, Three Rear Axles (One Pusher) or Two Rear Axles (One Pusher)

W5001637

See "Front Section, Battery Box, LH Side Behind Front Fender", page 15.

See "Front Section, Battery Box, LH Side Behind Fuel Tank", page 16.

See "Hill Start Assist Valves", page 18.

See "B Ride Suspension (Up to 46K)", page 25.

See "Hendrickson Suspension", page 28.

See "Hendrickson HN/RT Suspension", page 27.

Airline Routing for Aftertreatment Fuel Injector (AFI)

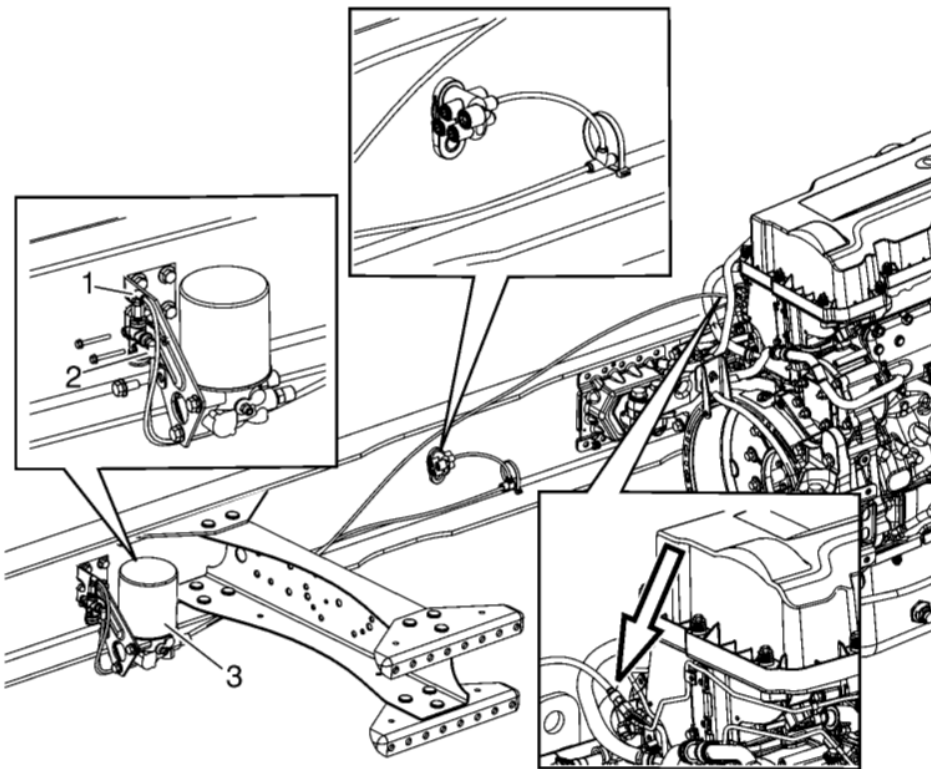

W5028804

- 1 Air supply line port
- 2 Port for delivery side of the pressure regulator valve
- 3 Coalescent air dryer

Middle Section, No Pusher

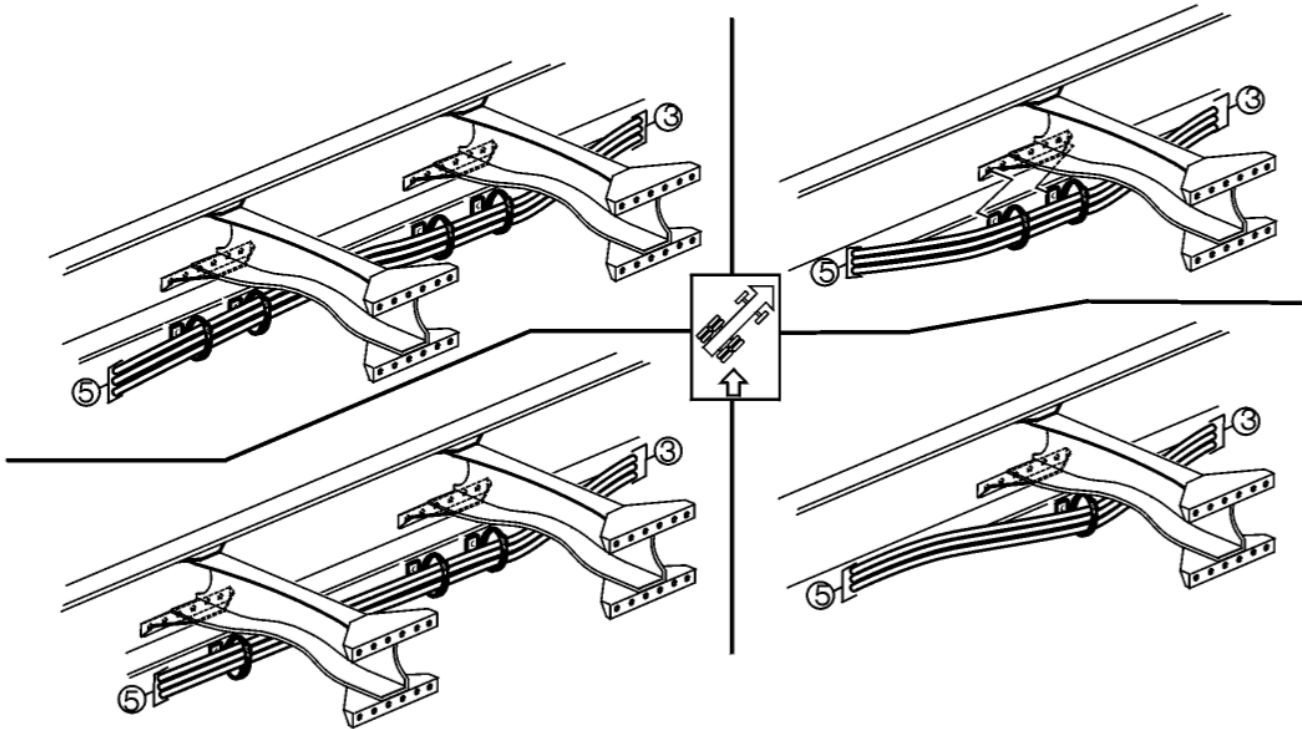

W5001160

See "Front Section, Battery Box, LH Side Behind Front Fender", page 15.

See "Front Section, Battery Box, LH Side Behind Fuel Tank", page 16.

See "Hill Start Assist Valves", page 18.

See "B Ride Suspension (Up to 46K)", page 25.

See "Hendrickson Suspension", page 28.

See "Hendrickson HN/RT Suspension", page 27.

B Ride Suspension (Up to 46K)

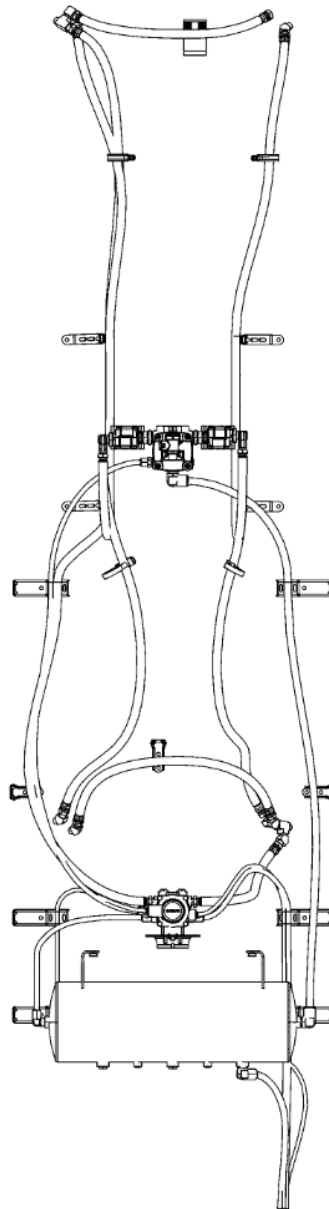

W7001447

See "Middle Section, No Pusher", page 24.
See "Middle Section, Three Rear Axles (One Pusher) or Two Rear Axles (One Pusher)", page 22.
See "Middle Section, Four Rear Axles (Two Pushers)", page 21.
See "Middle Section, Five Rear Axles (Three Pushers)", page 20.

T Ride Suspension (48K and Up)

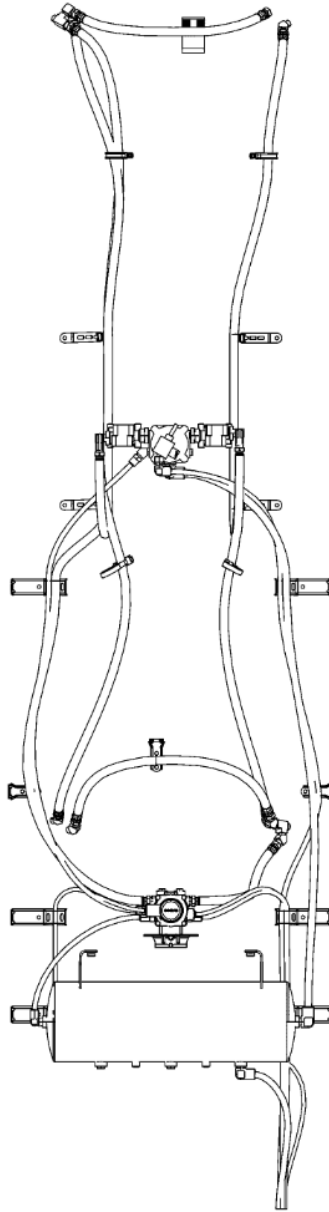

W5001602

See "Middle Section, No Pusher", page 24.
See "Middle Section, Three Rear Axles (One Pusher) or Two Rear Axles (One Pusher)", page 22.
See "Middle Section, Four Rear Axles (Two Pushers)", page 21.
See "Middle Section, Five Rear Axles (Three Pushers)", page 20.

Hendrickson HN/RT Suspension

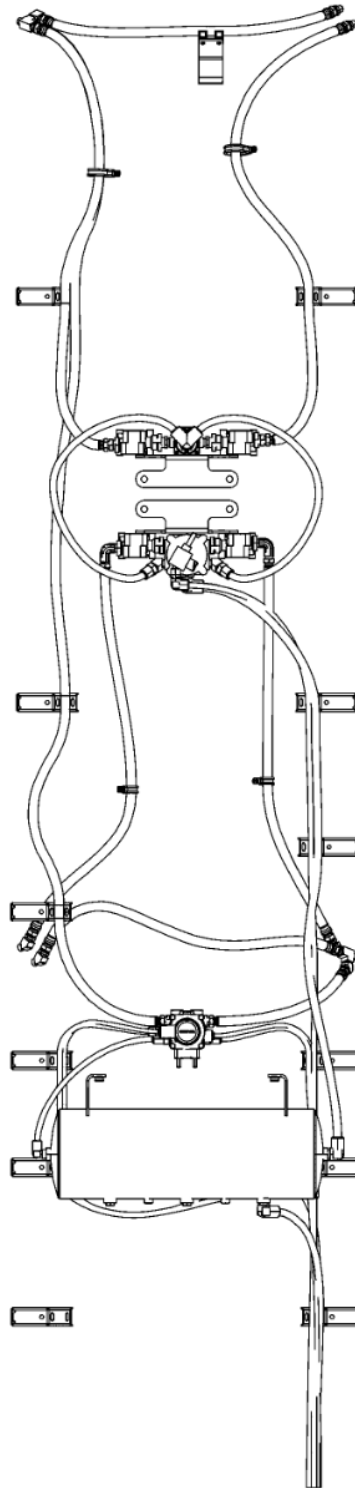

W5001603

See "Middle Section, No Pusher", page 24.
See "Middle Section, Three Rear Axles (One Pusher) or Two Rear Axles (One Pusher)", page 22.
See "Middle Section, Four Rear Axles (Two Pushers)", page 21.
See "Middle Section, Five Rear Axles (Three Pushers)", page 20.

Hendrickson Suspension

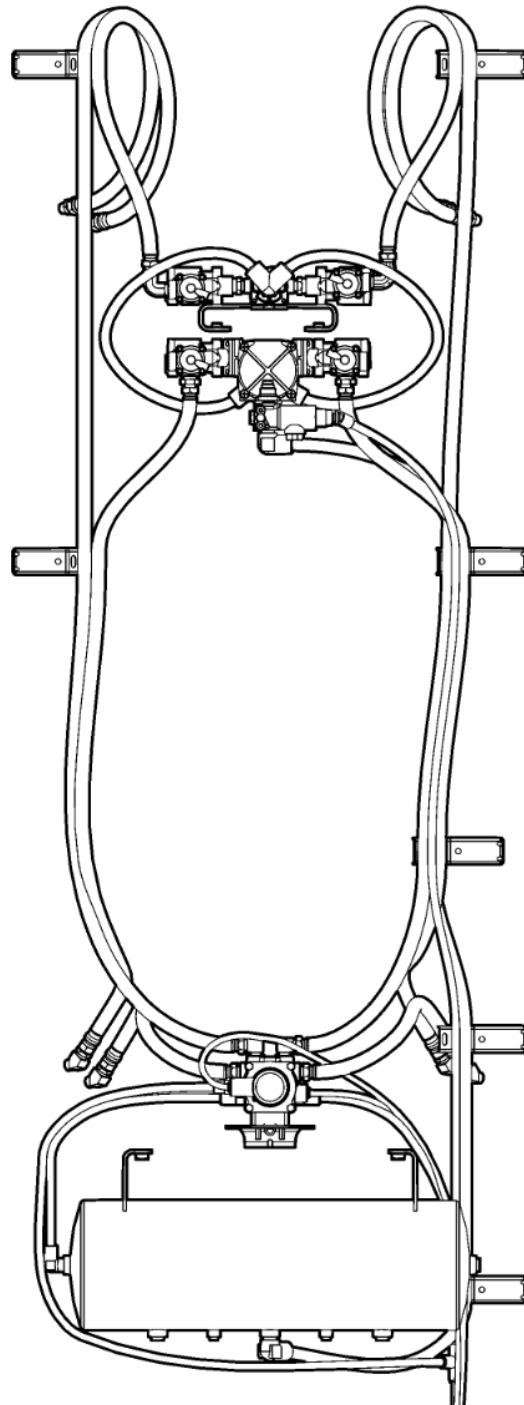

W5001604

See "Middle Section, No Pusher", page 24.
See "Middle Section, Three Rear Axles (One Pusher) or
Two Rear Axles (One Pusher)", page 22.
See "Middle Section, Four Rear Axles (Two Pushers)",
page 21.
See "Middle Section, Five Rear Axles (Three Pushers)",
page 20.

Brake Circuit Diagram

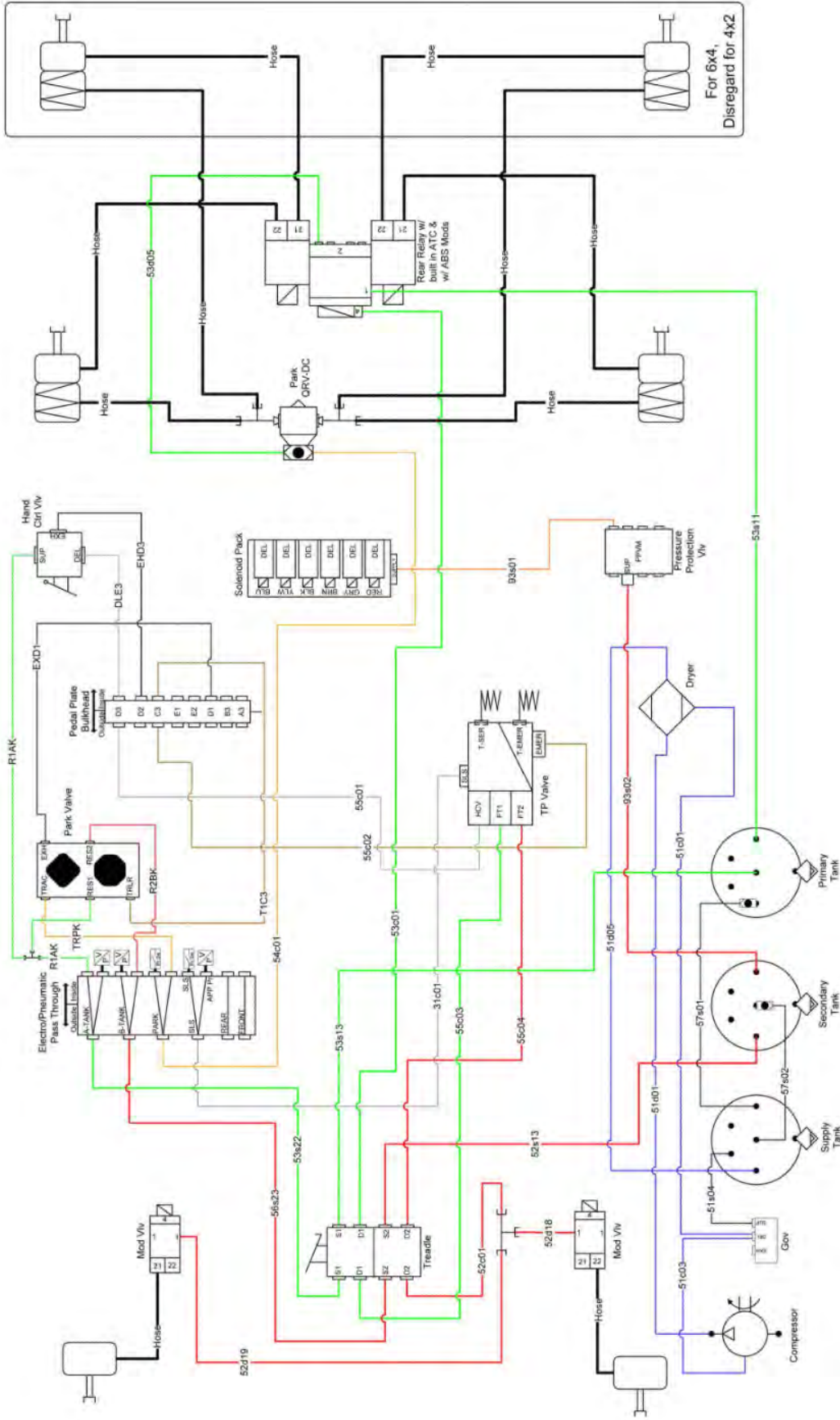

W5080702

Rigid with No Options

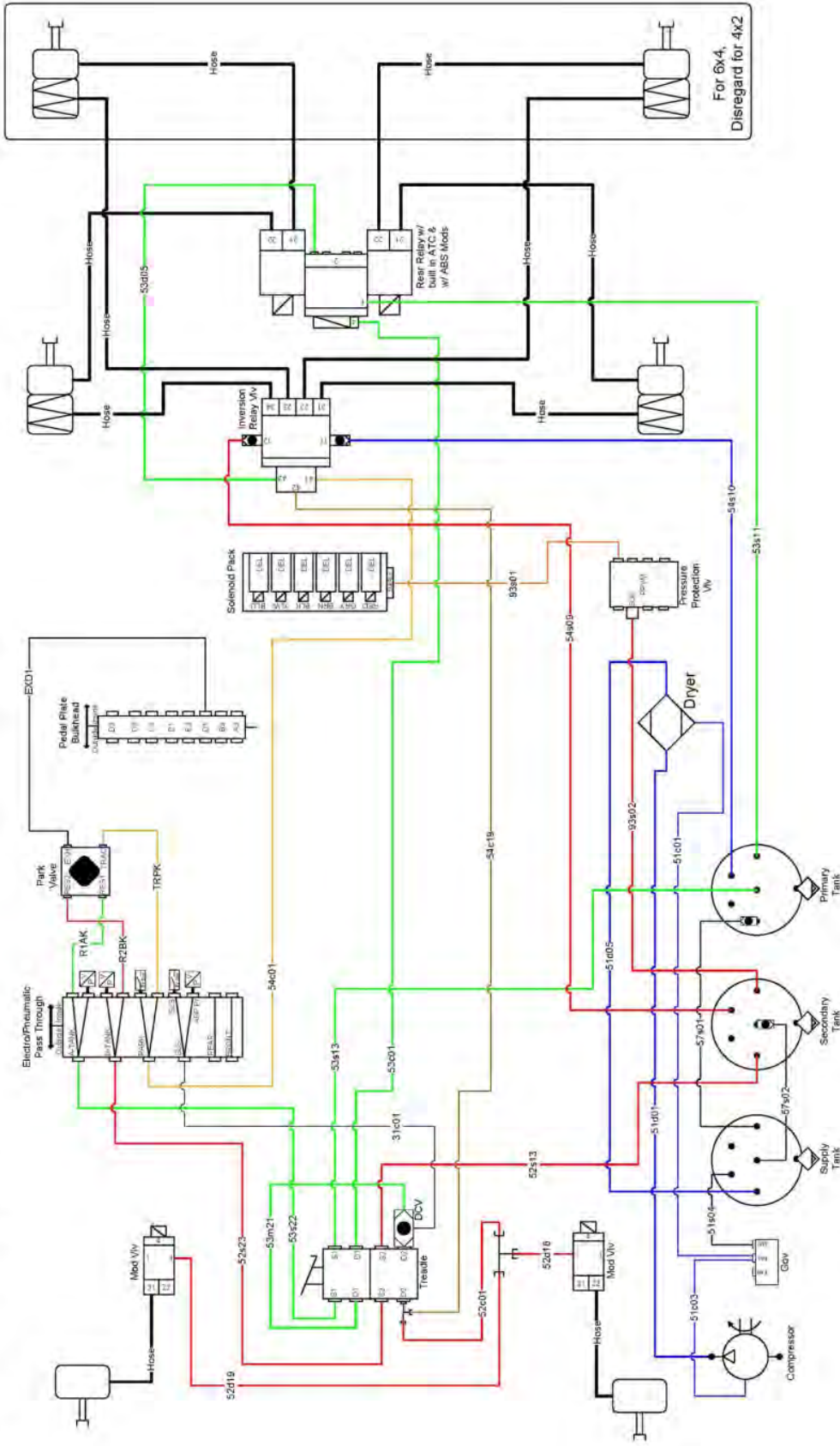

W5085393

Rigid with ESP

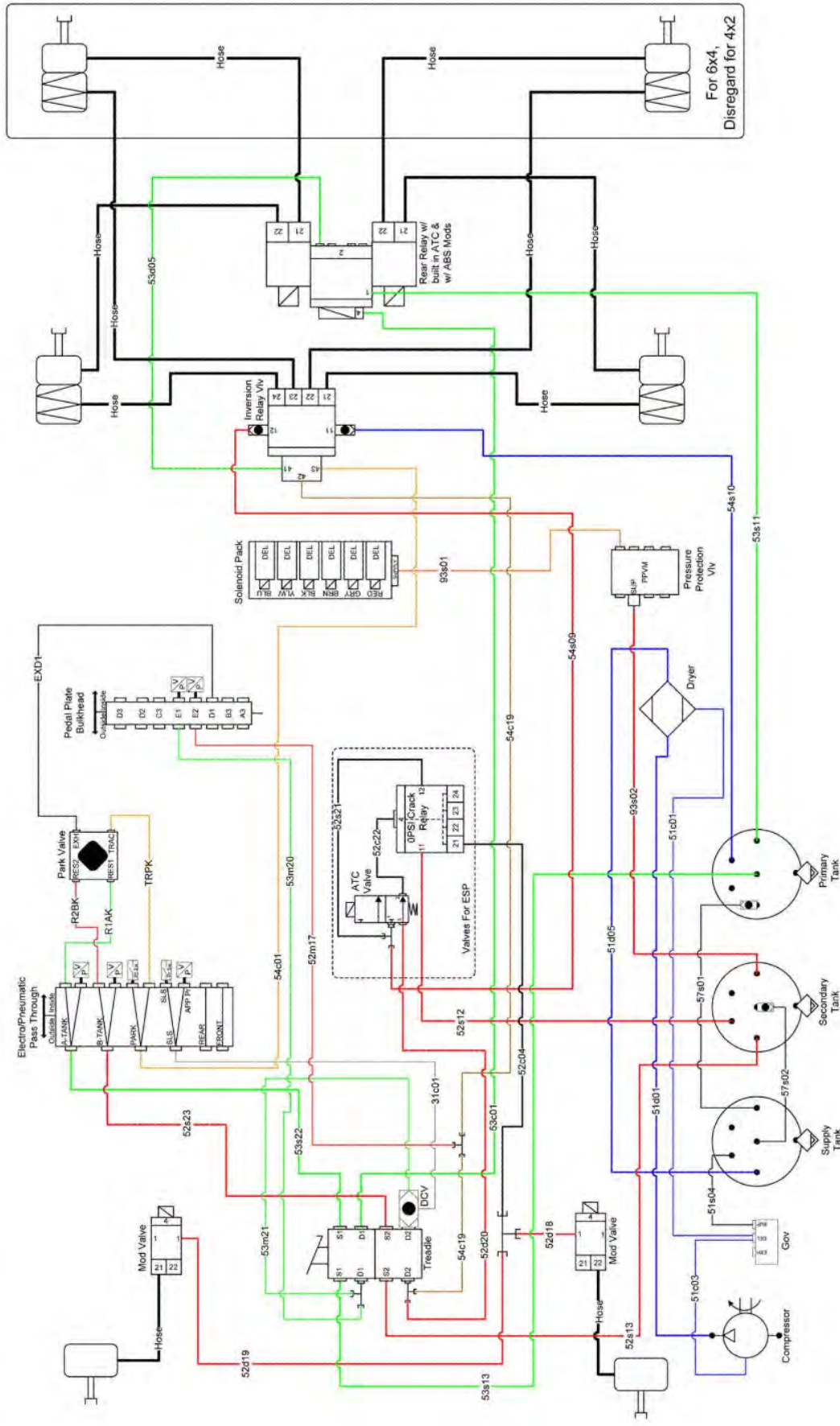

W5080683

Brake System Options

Many features and items have been removed for clarity.

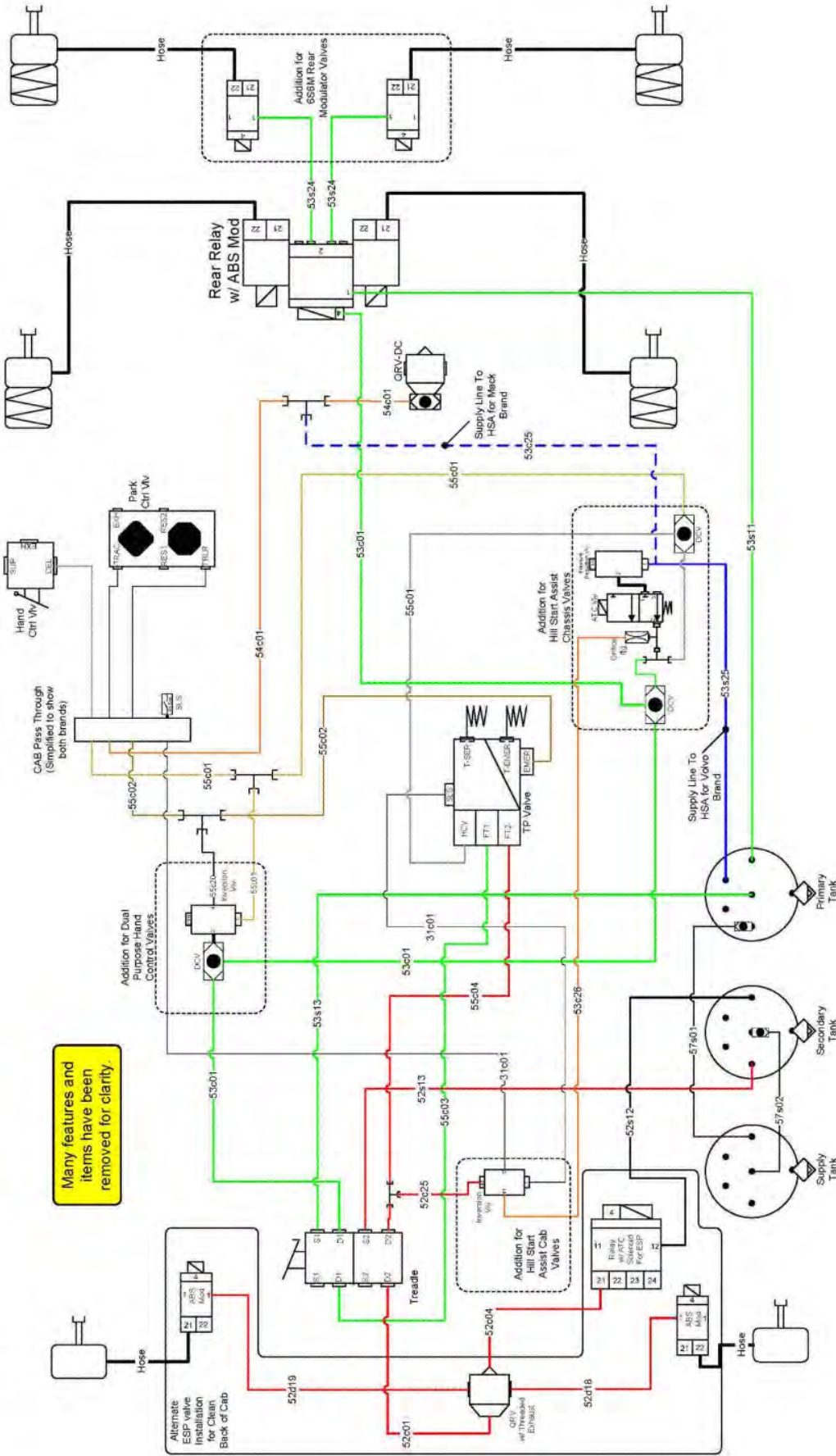

W5080688

Tri-Drive Brake System, Tractor

This schematic is intended to mainly show the brake system for the Tri-Drive. Many Parts outside of the rear brake valves have been deleted for clarity and drawing space.

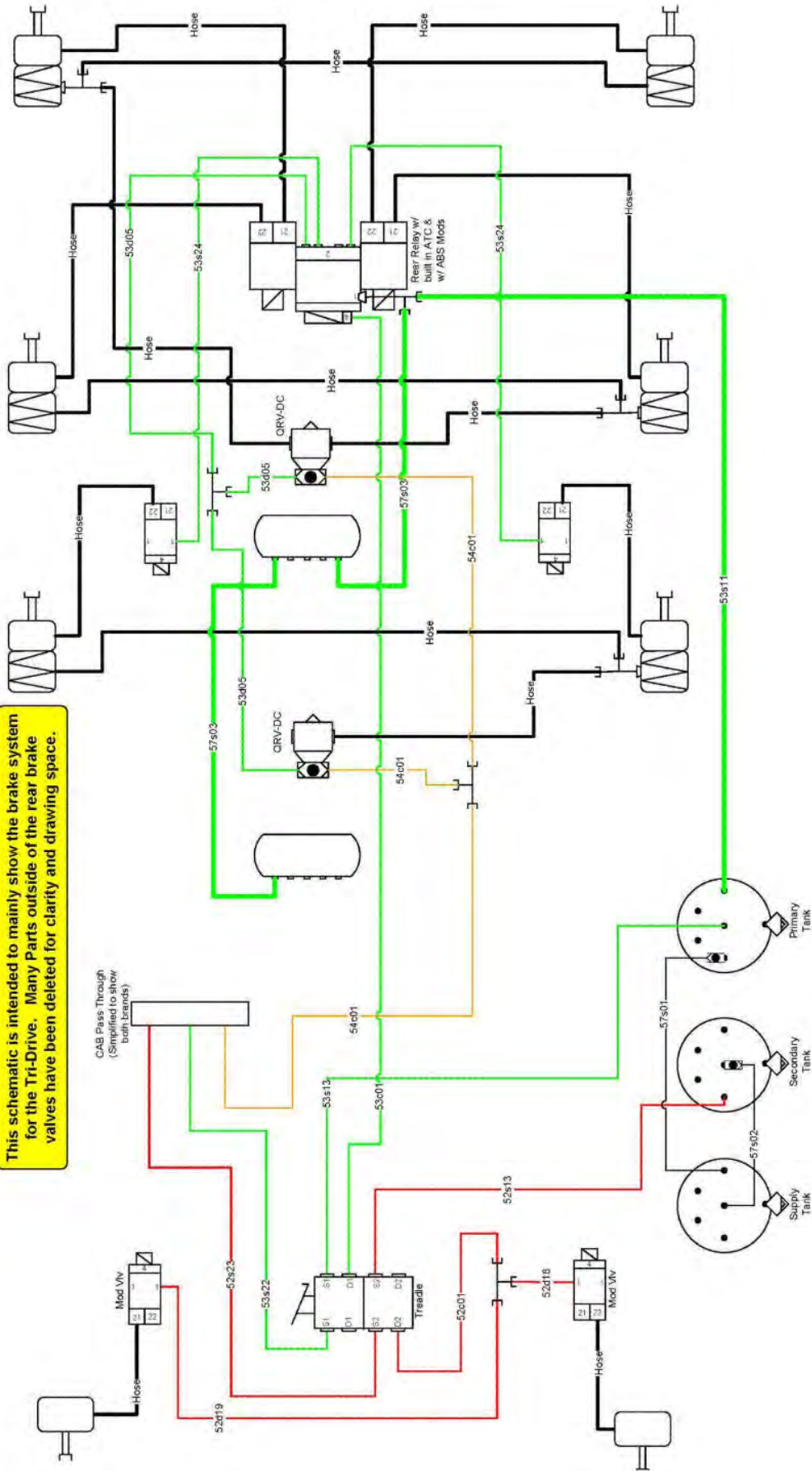

W5080689

Tri-Drive Brake System, Rigid

This schematic is intended to mainly show the brake system for the Tri-Drive. Many Parts outside of the rear brake valves have been deleted for clarity and drawing space.

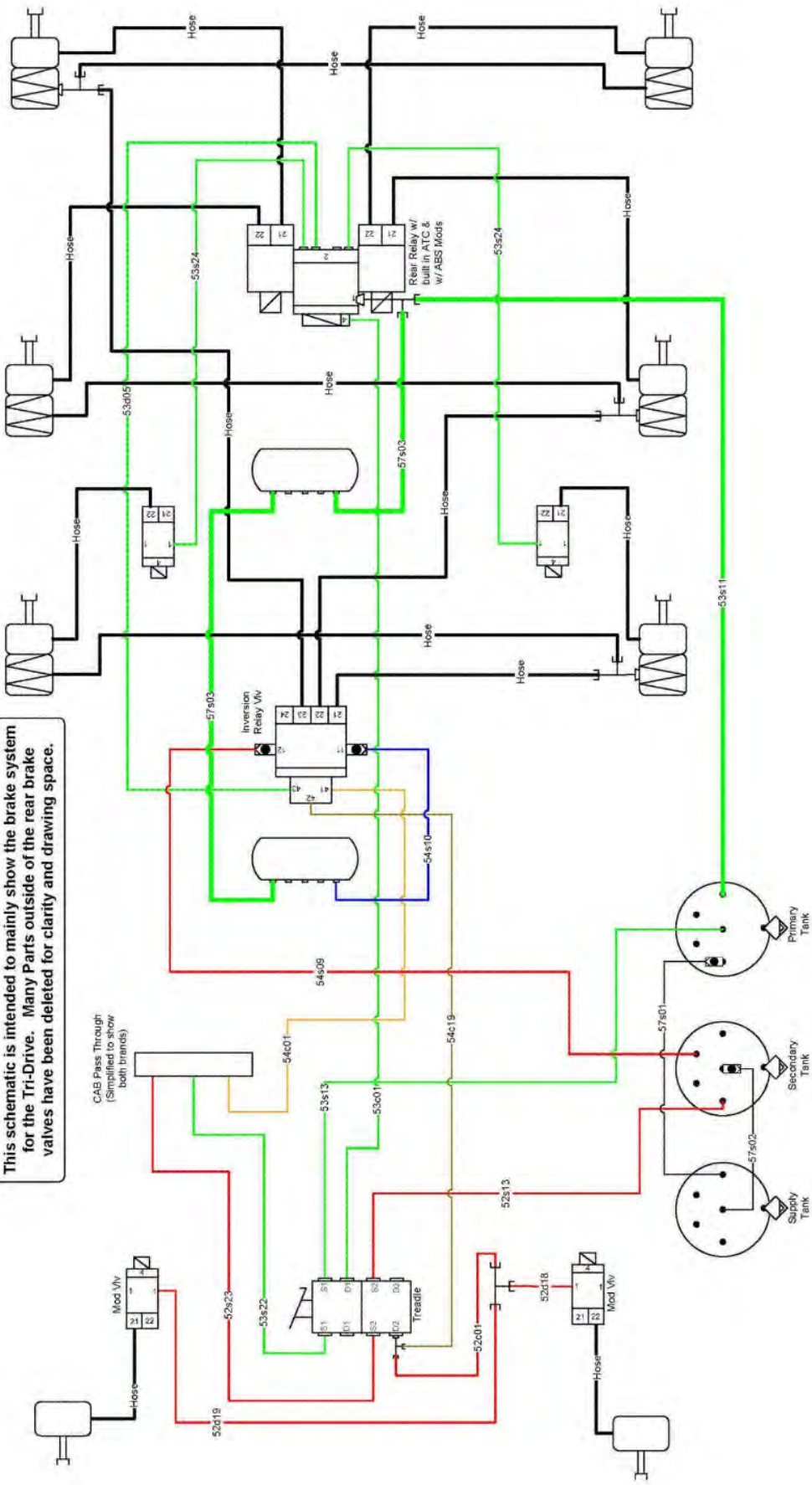

W5080690

One 13K and Smaller Auxiliary Axle Brake Circuit

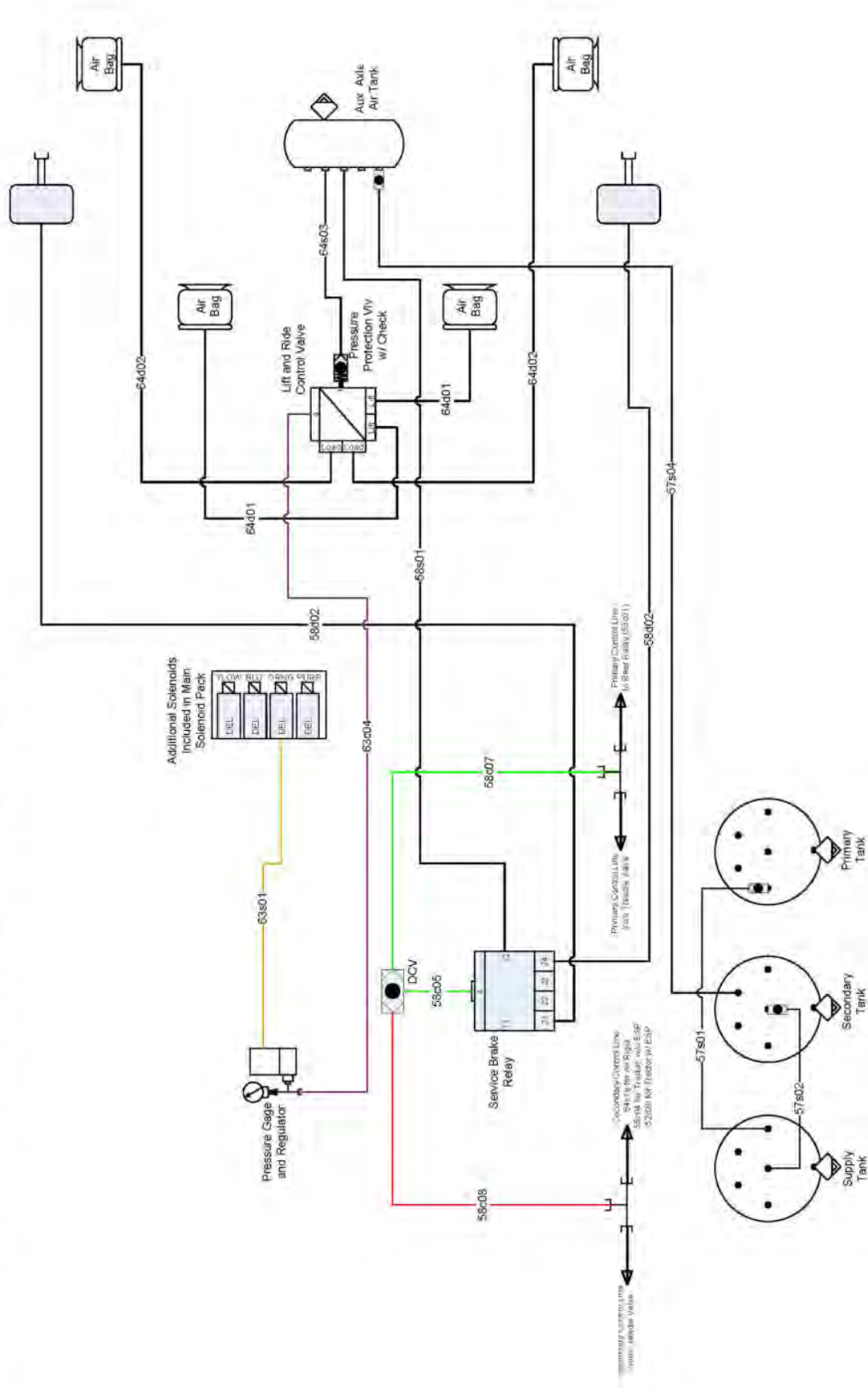

W5085396

Two 13K and Smaller Auxiliary Axle Brake Circuit

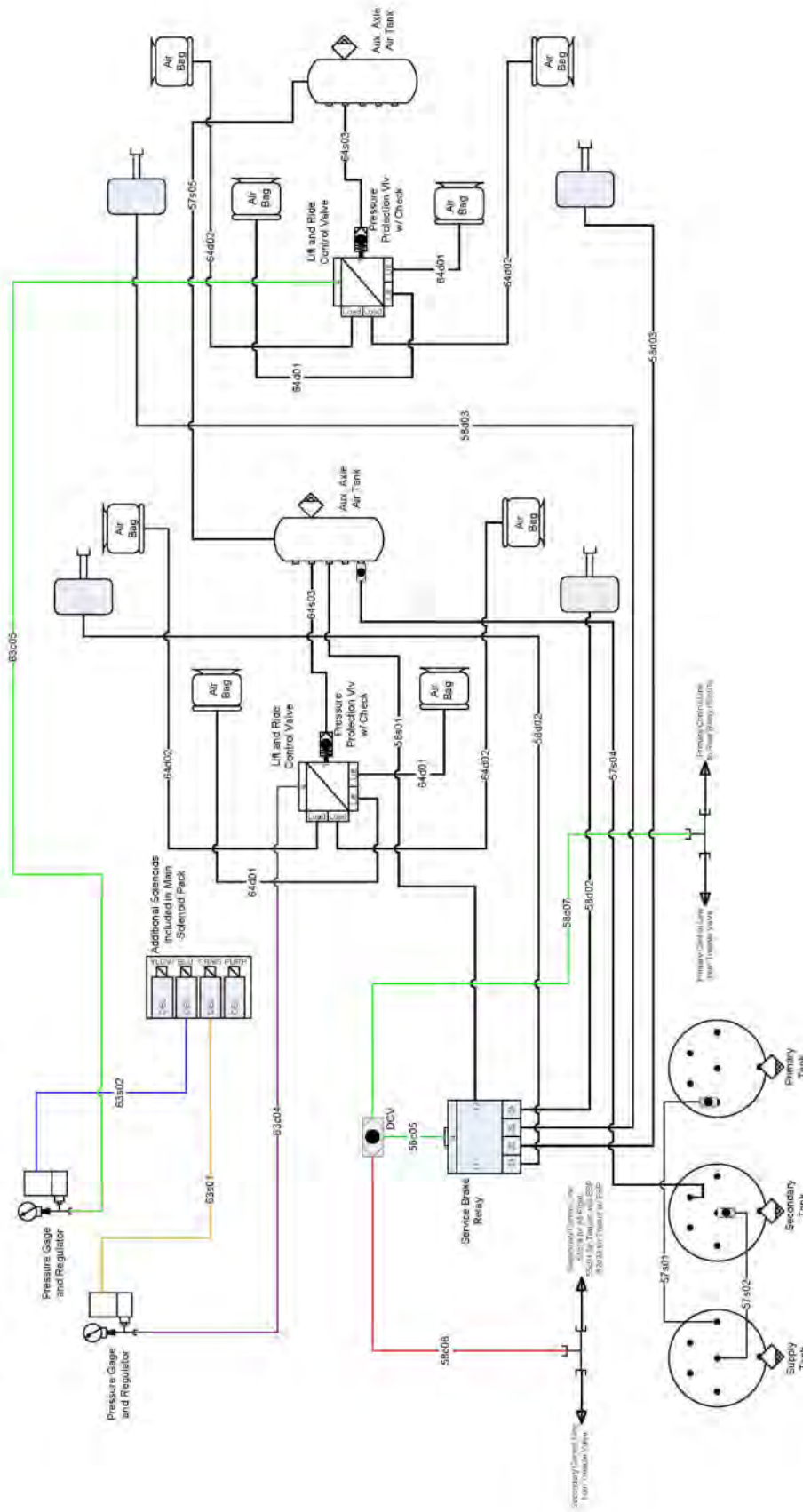

W5085304

One 20K Auxiliary Axle Brake Circuit

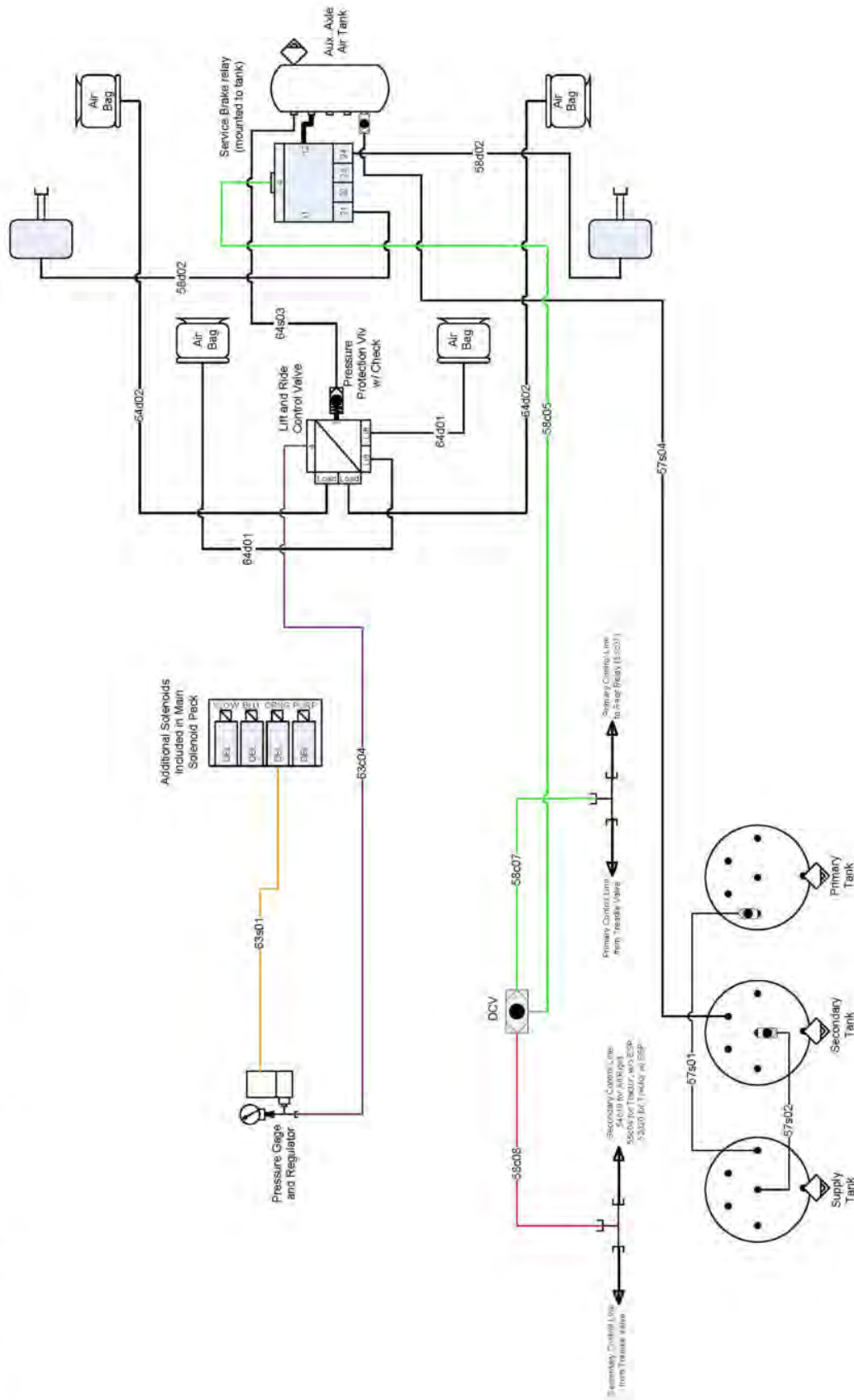

W51085395

Auxiliary Systems on Pressure Protected Circuits, Tri-Drive Suspension

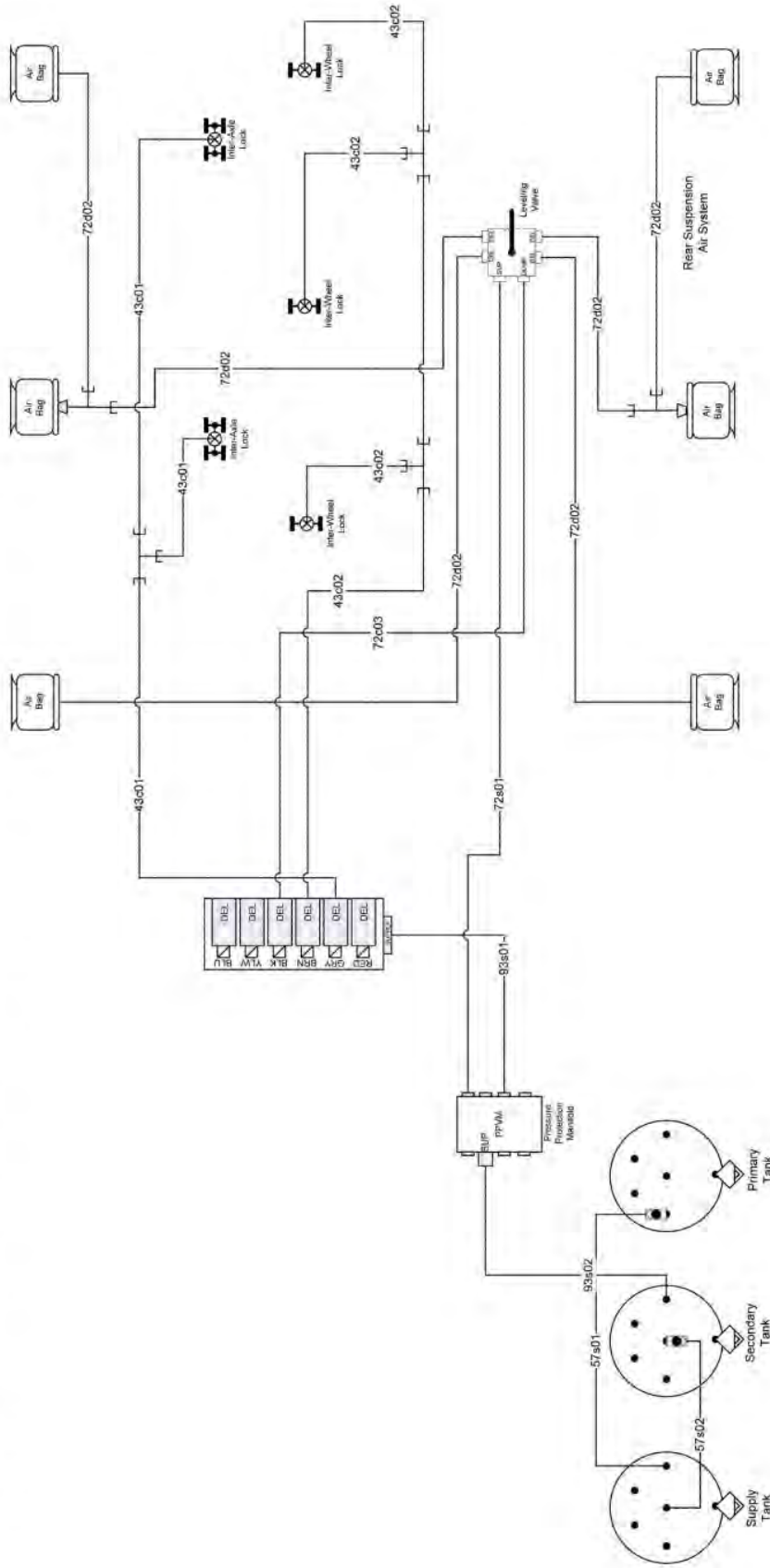

W5080695

Auxiliary Systems on Pressure Protected Circuits, 6x2 Suspension

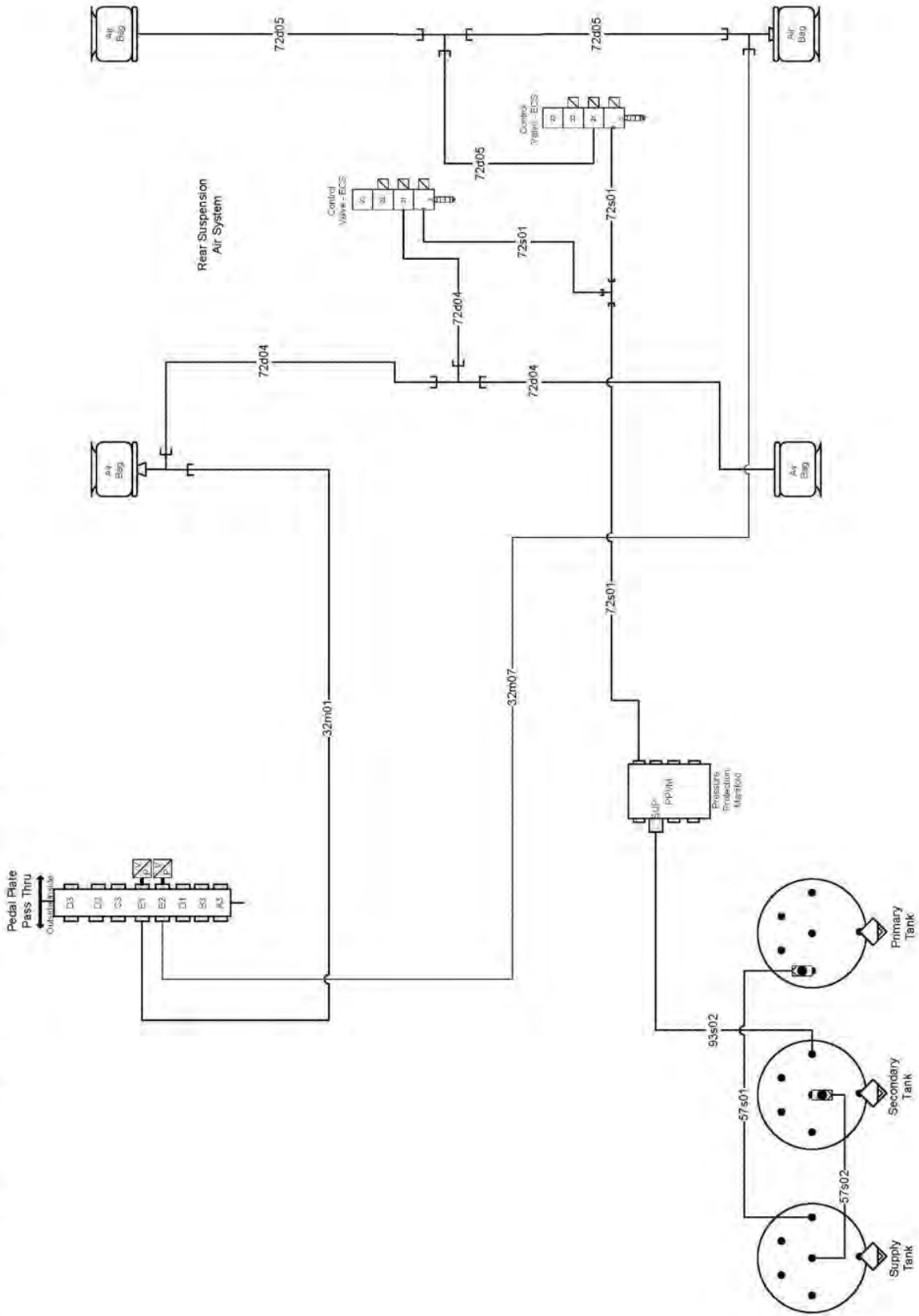

W5000696

Trailer Brake Systems, Back of Cab/End of Frame Trailer Connections with ESP

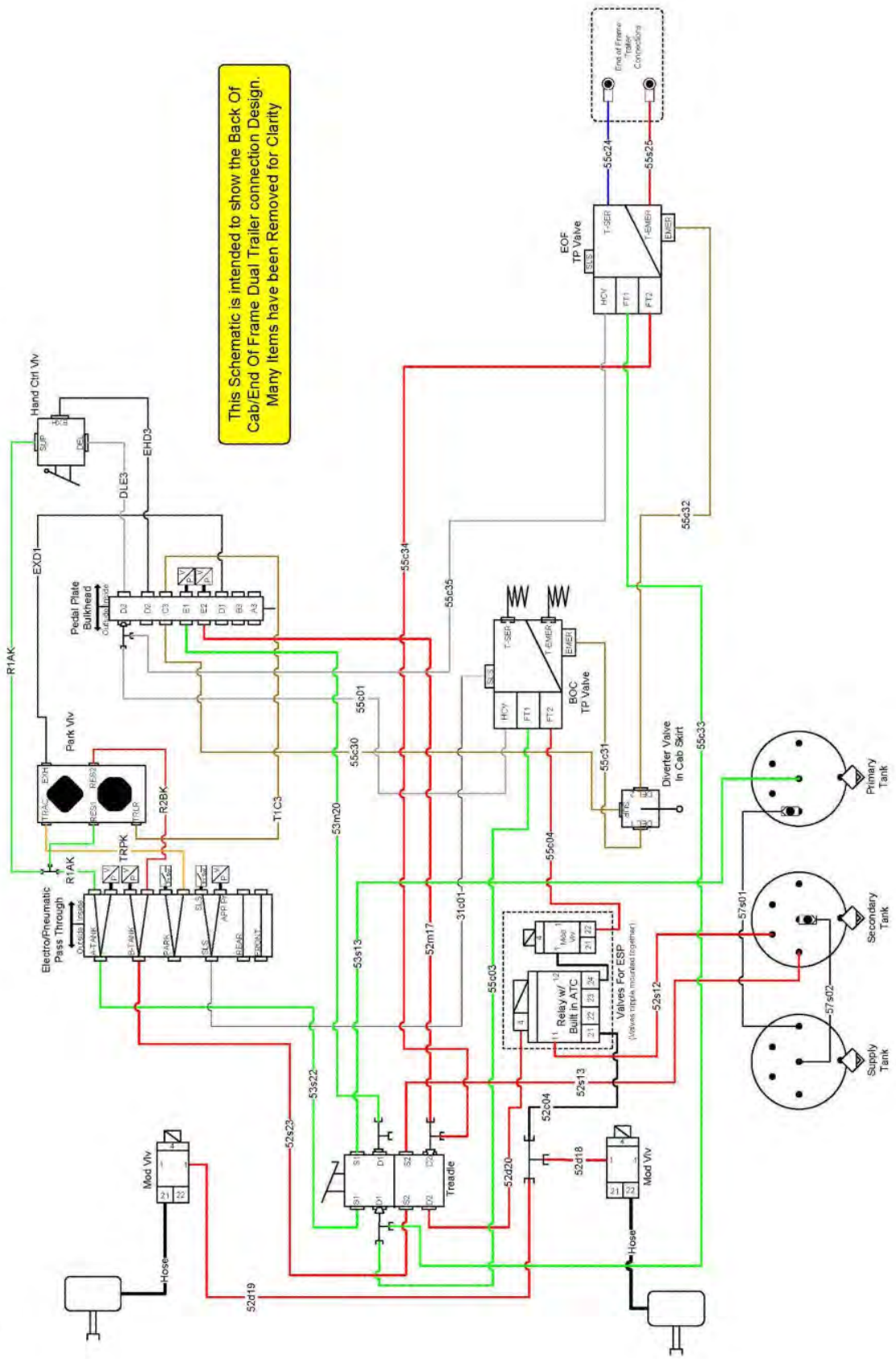

This Schematic is intended to show the Back Of Cab/End Of Frame Dual Trailer connection Design. Many Items have been Removed for Clarity

W5080697

VOLVO

Volvo Trucks North America, a division of Volvo Group North America, Inc.
Greensboro, NC USA

89096970 English 1000.10.2013 Printed in USA