

Field campaign

Topic	V8 Kovomo - New Continental GT/GTC and New Flying Spur - Valve spring replacement (SC21/41)
Market area	Bentley: worldwide (2WBE)
Brand	Bentley
Transaction No.	2065472/3
Campaign number	EC24
Note	
Type	
US code	

Vehicle data

New Continental GT/GTC and New Flying Spur

Sales types

Type	MY	Brand	Designation	Engine code	Gearbox code	Final drive code
3S32CB	2021	E		*	*	*
3S32CB	2022	E		*	*	*
3S42CB	2021	E		*	*	*
3S42CB	2022	E		*	*	*
ZG22CB	2021	E		*	*	*
ZG22CB	2022	E		*	*	*

Chas is numbers

Manufacturer	Filler	Type	Filler	MY	Factory	From	To	Prod from	Prod to
SCB	*	*	*	*	C	090579	093477		

Documents

Document name
master.xml
hydraulicliftingtable63x.pdf
install1-18.pdf
removal1-18.pdf
sc2141vinlist.pdf

Notes

▪ Repair instructions

Technical background

The intake valve springs (16) and outlet valve springs (16) located within the cylinder heads of Bank 1 and 2 require replacing
The replacement of all valve springs is required due to an issue which was discovered during a routine quality inspection

▪
VERY IMPORTANT: Before continuing with the onward instructions the operative should confirm if the symptoms within TPI 2064776/- are applicable

In the event the symptoms are applicable the operative MUST first conduct TPI 2064776/- to completion

The operative MUST then raise a new Technical DISS query or respond via the already open DISS query and await feedback from Product Support before conducting any further work as further information will be requested back which may change the method of repair

Remedy

The replacement of all intake valve springs and all outlet valve springs (Bank 1 and Bank 2) is required

▪
IMPORTANT: The removal and installation instructions are attached to this document, the operative MUST ensure the instructions are followed in numerical order as detailed within the work section

NOTE: There is also a separate attachment with instructions regarding the hydraulic lifting table which must be followed

NOTE: The Work section also contains task applicable instructions which MUST also be referred to and conducted. The instructions can change without warning, the operative must always ensure the latest version of this document and the attached instructions are referred to (Use the applicable VIN in Elsa pro to ensure latest version is always referred to)

TIP: The removal and installation procedures have been specifically devised, all procedures MUST be strictly adhered to

Customer notification

The procedure must be carried out in conjunction with the PDI process

Warranty accounting instructions

Replacement of the intake and outlet valve springs

Warranty type 790

Damage service number EC24

Damage code 0066

Criteria 01

Labour

Labour Operation Code 15 65 56 20 (Use 99 index until 17/02/22)

Time 2190 TU

Alignment of applicable driver assist systems (Depending on vehicle specification)

NOTE: The codes for each vehicle type are the same, however some of the times may be different please note that Saga will auto-populate the times when the claim is submitted

- Vehicle front + rear measured wheel alignment checked - 44 95 03 00
- Rear wheel camber adjust - 44 94 15 50
- Rear wheel track adjust - 44 93 15 50
- Front wheel camber adjust - 44 89 15 50
- Front wheel track adjust - 44 88 15 50
- (ACC) - Radar sensor checked + adjusted - 91 63 05 51
- Overhead view camera adjusted - 90 83 15 00
- Driver assist camera adjusted - 96 38 15 50
- Control unit for (Lane change assist) adjusted - 96 35 15 00
- Night vision system calibration - 90 80 15 50

- Headlamps to adjust - 94 15 16 00
- ODISTime-01500000(Time as per ODISlog)

Genuine parts

Part number	Description	Quantity
06E109623AD	Intake valve springs	16
0P2109623	Outlet valve springs	16
3SA198115	Parts set	1
0P2103484	Seal	1
0P2103517	Seal	1
G052565A1	Silicone paste	As required
N10458202	Hexagon bolt M6x22	4
WHT007821	O-ring 31x2	2
WHT008638	O-Ring 17.5x1.5	8
04E998907A	Repair kit for valve unit	8
D176501A1	Loctite 5970- BM (Source locally)	As required
04E906145	Seal ring	4
06M145113	Seal	1
034115427B	O-Ring 12x2	1
0P2103650E	Gasket for cover Cylinders 1-4	1
0P2103649E	Gasket for cover Cylinders 5-8	1
0P2103113A	Cover	3
06M109235	Seal	4
06M109493D	Plate	4
0P2129056	Seal	2
WHT008730	O-Ring 12x3	2
WHT008729	O-Ring 14x3	2
N90344501	O-Ring 45x3	2
N90521604	O-Ring 55x3	2
99970751741	O-Ring 22x3	2
N90365304	O-Ring 20x3	1
N90925001	O-Ring 17x3	3
971253115B	Turbo to pre catalytic seal	2
8W0253725D	Clamp for turbochargers	2
5Q0253115B	Downpipe to pre catalytic seal	2
982251616	Band clamp	2
Refer to ETKA and Rep.Gr00 (Power transmission fluids and capacities)	Differential oil (front and centre)	As required

Refer to ETKA and Rep.Gr 00 (Power transmission fluids and capacities)	Transmission fluid	As required
Refer to ETKA and Rep.Gr 00 (Engine fluids and capacities)	Engine coolant	As required
00004320935	Microgleit DF977S (Source locally)	As required
Loctite 7515 primer	Loctite 7515 primer (Source locally)	As required

Parts supply

All parts listed within this document are currently restricted and will follow a specific process to minimise disruption for Retailers and ensure delivery is received in complete vehicle sets.

Please do not raise any unnecessary part orders or service calls.

Parts despatch control

The parts will be controlled centrally and automatically allocated and distributed therefore in this case there is no requirement for retailers to place orders.

Repair instructions

■ Notes

Technical background

The intake valve springs (16) and outlet valve springs (16) located within the cylinder heads of Bank 1 and 2 require replacing
The replacement of all valve springs is required due to an issue which was discovered during a routine quality inspection

VERY IMPORTANT: Before continuing with the onward instructions the operative should confirm if the symptoms within TPI 2064776/- are applicable

In the event the symptoms are applicable the operative MUST first conduct TPI 2064776/- to completion

The operative MUST then raise a new Technical DISS query or respond via the already open DISS query and await feedback from Product Support before conducting any further work as further information will be requested back which may change the method of repair

Check

If the vehicle is not already listed as repaired in the "Repair history" (in Elsa Pro) refer to the Identification section to check the presence of the yellow paint completion mark (Figure 5)

Should neither be evident ("Repair history" or applicable paint mark) carry out the required work in accordance with these instructions

Genuine parts

Part number	Description	Quantity
06E109623AD	Intake valve springs	16
0P2109623	Outlet valve springs	16
3SA198115	Parts set	1
0P2103484	Seal	1
0P2103517	Seal	1
G052565A1	Silicone paste	As required
N10458202	Hexagon bolt M6x22	4
WHT007821	O-ring 31x2	2
WHT008638	O-Ring 17.5x1.5	8
04E998907A	Repair kit for valve unit	8
D176501A1	Loctite 5970- BM (Source locally)	As required
04E906145	Seal ring	4

06M145113	Seal	1
034115427B	O-Ring 12x2	1
0P2103650E	Gasket for cover Cylinders 1-4	1
0P2103649E	Gasket for cover Cylinders 5-8	1
0P2103113A	Cover	3
06M109235	Seal	4
06M109493D	Plate	4
0P2129056	Seal	2
WHT008730	O-Ring 12x3	2
WHT008729	O-Ring 14x3	2
N90344501	O-Ring 45x3	2
N90521604	O-Ring 55x3	2
99970751741	O-Ring 22x3	2
N90365304	O-Ring 20x3	1
N90925001	O-Ring 17x3	3
971253115B	Turbo to pre catalytic seal	2
8W0253725D	Clamp for turbochargers	2
5Q0253115B	Downpipe to pre catalytic seal	2
982251616	Band clamp	2
Refer to ETKA and Rep.Gr 00 (Power transmission fluids and capacities)	Differential oil (front and centre)	As required
Refer to ETKA and Rep.Gr 00 (Power transmission fluids and capacities)	Transmission fluid	As required
Refer to ETKA and Rep.Gr 00 (Engine fluids and capacities)	Engine coolant	As required
00004320935	Microgleit DF977S (Source locally)	As required
Loctite 7515 primer	Loctite 7515 primer (Source locally)	As required

Tools

Refer to the attached instructions

Work

1) To gain access/to replace all of the Intake and Outlet valve springs - Refer to the attached instructions ensuring each process is conducted in numerical order (1 through to 18) as follows:

▪

IMPORTANT: Ensure the engine and transmission is suitably secured to the hydraulic lifting table and ensure the attached hydraulic lifting table instructions are followed

Removal

- 1 - Remove engine
- 2 - Remove exhaust downpipes, heatshields and catalytic converters
- 3 - Remove rear high-pressure fuel line
- 4 - Remove upper chain housing covers
- 5 - Remove oil mist separators
- 6 - Remove ignition coils

7 - Remove high pressure fuel lines, banks 1 and 2

8 - Remove high pressure fuel pumps

9 - Remove fuel rails

10 - Remove CDA solenoids

11 - Remove fuel injectors

12 - Remove mechanical vacuum pump

13 - Remove pressure pipes

14 - Remove camshaft actuators 15

- Remove cylinder head cover

16 - Remove valve lifters (hydraulic tappets) 17 -

Remove spark plugs

18 - Remove valve springs

NOTE: It is imperative the attached instructions are followed in numerical order as each task has been individually generated to allow the operative to conduct the rework with minimal disruption

VERY IMPORTANT: The operative MUST ensure the valve springs are fitted in the correct location as the part numbers of the Intake valves and Outlet valves are different.

TIP: To ensure consistency/accuracy during the replacement of the valve spring process and to ensure the springs are fitted in the correct location, it is highly recommended the same operative is used for the duration of this process

- 06E 109 623AD - Intake valve springs - Figure 1 (Located on the outside edge of each bank)

HINT: Referring to Figure 1 - The valve spring is shown in the orientation as it should be fitted IMPORTANT: The 3 white lines shown/circled on the upper face of the spring must be facing upwards when fitted



Figure 1

- 0P2 109 623 - Outlet valve springs - Figure 2 (Located on the inside of each bank)

HINT: Referring to Figure 2 - The valve spring is shown in the orientation as it should be fitted IMPORTANT: The 4 blue lines shown/circled on the upper face of the spring must be facing upwards when fitted



Figure 2

NOTE: Once the engine is removed there is not a requirement to separate the transmission from the engine, the replacement of the valve springs should be conducted with the engine and transmission sitting on the hydraulic lifting table

CAUTION: Ensure the engine and transmission is suitably secured to the hydraulic lifting table

TIP: When removing the original parts it is best practice to keep the new parts completely separate to eliminate cross contamination between the old and new parts

HINT: Ensure all parts which are not required to be replaced as part of this process are inspected prior to refitting and replaced if required

▪
VERY IMPORTANT: When replacing the valve springs (once the collets and valve spring cap is removed from each valve) it is imperative that constant air pressure is supplied to the affected cylinder whilst the replacement of the valve springs is being conducted, in the event the air supply is lost or is not maintained during this operation, the valve could drop directly into the cylinder resulting in the requirement to remove the cylinder head to retrieve the valve

2) To complete the installation of the valve springs - Refer to the attached installation instructions in numerical order

▪
VERY IMPORTANT: The operative MUST ensure the valve springs are fitted in the correct location as the part numbers of the Intake valves and Outlet valves are different.

TIP: To ensure consistency/accuracy during the replacement of the valve spring process and to ensure the springs are fitted in the correct location, it is highly recommended the same operative is used for the duration of this process

INSTALLATION

1 - Install valve springs

2 - Install spark plugs

3 - Install valve lifters (hydraulic tappets) 4

- Install cylinder head covers

5 - Install camshaft actuators (includes setting timing) 6 -

Install pressure pipes

7 - Install mechanical vacuum pump 8

- Install fuel injectors

9 - Install cylinder deactivation solenoids 10

- Install fuel rails

11 - Install high pressure fuel pumps

12 - Install high pressure fuel lines, banks 1 and 2

13 - Install ignition coils

14 - Install oil mist separators

15 - Install upper chain housing covers

16 - Install rear high-pressure fuel line

17 - Install catalytic converters, exhaust downpipes and heatshields 18 -

Install engine

3) Carry out wheel alignment and ensure the driver assist system calibrations are performed (Depending on vehicle specification) as follows

- Vehicle front + rear measured wheel alignment checked
- Rear wheel camber adjust
- Rear wheel track adjust
- Front wheel camber adjust
- Front wheel track adjust
- (ACC) - Radar sensor checked + adjusted
- Overhead view camera adjusted
- Driver assist camera adjusted
- Control unit for (Lane change assist) adjusted
- Night vision system calibration
- Headlamps to adjust

4) Raise a non-technical DISS query attaching the following:

- Before and after screen shots of the wheel alignment results

- Screen shots confirming the applicable drive assist systems have been successfully adjusted/calibrated

Warranty payments will not be approved without the submission of the requested results via the open DISS query

5) Conduct the PDI road test - On return confirm that no DTC's are evident

6) Check and confirm that no DTC's are stored or there are no engine operation issues evident - Save an online log to confirm that no DTC's were evident at this stage of the procedure

- Referring to Figure 3
- Select Guided functions from 01 – Engine Control Module 1
- Select Generate readiness code
- Select Execute

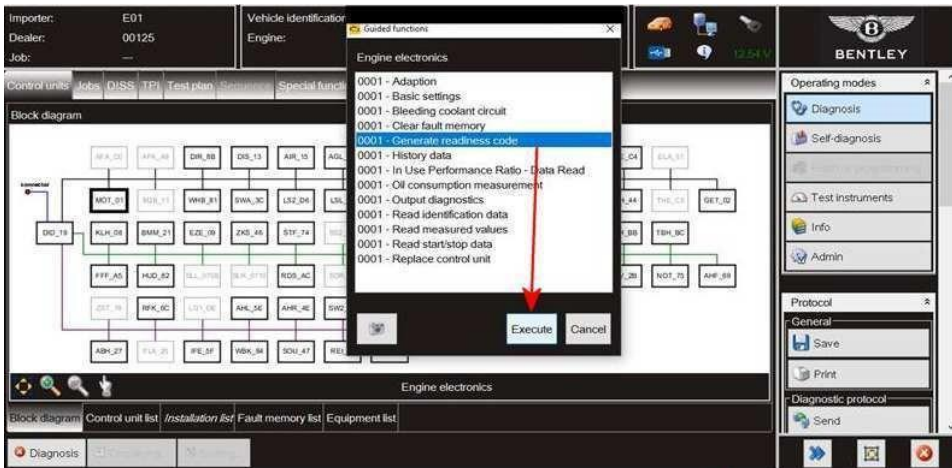

Figure 3

Please be aware that not all readiness bytes may be at zero, however this is not a requirement as the remaining bytes will set during normal customer driving cycle routines

7) Confirm no oil/fluid leaks are evident

8) Place a yellow paint completion mark as shown within the Identification section (Figure 4)

Identification

Yellow paint completion mark on the right hand side of the engine partition brace (Figure 4)



Figure 4

New Continental GT V8 Kovomo

SCBCZ13S5MC090579	SCBCX13S9NC092553	SCBCX13S3NC092998
SCBCZ13S2MC090586	SCBCG2ZG8NC092567	SCBCX13S7NC093006
SCBCZ13S1MC090594	SCBCZ13S2NC092596	SCBCG2ZG9NC093016
SCBCG2ZG1NC090885	SCBCG13S0NC092599	SCBCG2ZG2NC093018
SCBCG2ZG7NC090986	SCBCG2ZG6NC092602	SCBCX13S5NC093019
SCBCF13S1NC091108	SCBCG13S8NC092608	SCBCX13S5NC093022
SCBCF13S4NC091166	SCBCF13SXNC092614	SCBCG2ZG9NC093033
SCBCF13S7NC091193	SCBCZ13S6NC092617	SCBCJ13S7NC093041
SCBCF13S9NC091213	SCBCX13S3NC092628	SCBCG2ZG1NC093043
SCBCF13S7NC091274	SCBCG13S6NC092641	SCBCF1ZG6NC093052
SCBCG2ZG2NC091303	SCBCF13SXNC092645	SCBCG2ZG3NC093058
SCBCG2ZG4NC091304	SCBCG2ZG6NC092650	SCBCF1ZG7NC093061
SCBCZ13S2NC091321	SCBCG2ZGXNC092652	SCBCG2ZG4NC093070
SCBCZ13S0NC091365	SCBCG2ZG0NC092658	SCBCJ13S9NC093073
SCBCG2ZG5NC091456	SCBCG2ZG2NC092662	SCBCF1ZG4NC093096
SCBCF13S5NC091502	SCBCG2ZG1NC092670	SCBCG2ZG6NC093099
SCBCG2ZG0NC091509	SCBCG13S8NC092690	SCBCG2ZG5NC093109
SCBCG13S2NC091597	SCBCF1ZG1NC092701	SCBCG2ZG4NC093117
SCBCX13S4NC091598	SCBCX13S7NC092714	SCBCX13S1NC093129
SCBCX13S0NC091601	SCBCG2ZG8NC092729	SCBCF1ZG2NC093131
SCBCJ13S9NC091727	SCBCG2ZG9NC092738	SCBCX13S0NC093137
SCBCX13S1NC091753	SCBCG2ZGXNC092747	SCBCG2ZG0NC093146
SCBCZ13S8NC091761	SCBCZ13S1NC092752	SCBCF1ZG3NC093154
SCBCZ13S2NC091769	SCBCG2ZGXNC092764	SCBCG2ZG7NC093158
SCBCZ13S6NC091788	SCBCG2ZG5NC092767	SCBCF13SXNC093164
SCBCG2ZG8NC091791	SCBCG2ZG5NC092770	SCBCZ13S6NC093167
SCBCG13S6NC091909	SCBCG2ZG8NC092777	SCBCG2ZG8NC093170
SCBCX13S8NC091913	SCBCG2ZG3NC092783	SCBCG2ZG4NC093182
SCBCG13S3NC091950	SCBCG13S0NC092795	SCBCG2ZG1NC093186
SCBCG2ZG7NC092222	SCBCG2ZG4NC092808	SCBCG2ZG7NC093192
SCBCG13S0NC092229	SCBCF13S7NC092814	SCBCX13S9NC093198
SCBCG2ZG0NC092238	SCBCG2ZG1NC092829	SCBCF1ZG6NC093228
SCBCF13S7NC092263	SCBCZ13S9NC092837	SCBCG2ZG7NC093242
SCBCG2ZG5NC092316	SCBCG13S7NC092843	SCBCG2ZG7NC093256
SCBCG2ZG0NC092322	SCBCZ13S5NC092849	SCBCG2ZG9NC093260
SCBCX13S1NC092336	SCBCZ13S6NC092861	SCBCG2ZG6NC093264
SCBCF13S7NC092389	SCBCZ13S0NC092872	SCBCF13S9NC093267
SCBCG2ZG5NC092395	SCBCG13S7NC092907	SCBCX13S1NC093275
SCBCG2ZG2NC092399	SCBCF13S3NC092910	SCBCG2ZG4NC093375
SCBCG2ZG7NC092429	SCBCF1ZG0NC092916	SCBCF1ZGXNC093443
SCBCF13S0NC092430	SCBCJ13S1NC092919	SCBCG2ZG6NC093457
SCBCZ13S3NC092462	SCBCF1ZG9NC092929	SCBCF1ZG1NC093461
SCBCF13S9NC092474	SCBCF13S3NC092941	
SCBCG2ZG7NC092480	SCBCG13S2NC092944	
SCBCJ13SXNC092482	SCBCG2ZG9NC092951	
SCBCG2ZG8NC092486	SCBCG2ZG4NC092954	
SCBCG13S2NC092488	SCBCG2ZG1NC092961	
SCBCX13S2NC092510	SCBCG2ZG5NC092963	
SCBCZ13S7NC092514	SCBCX13SXNC092965	
SCBCJ13S3NC092520	SCBCG2ZG4NC092971	
SCBCZ13SXNC092524	SCBCF13S5NC092973	
SCBCG2ZG5NC092526	SCBCG2ZG1NC092975	
SCBCZ13S5NC092530	SCBCX13S5NC092985	
SCBCG2ZG4NC092534	SCBCX13S0NC092988	
SCBCX13S2NC092538	SCBCG2ZG8NC092990	
SCBCG2ZG0NC092546	SCBCX13S8NC092995	

New Continental GTC V8 Kovomo

SCBDG4ZG2NC090815	SCBDX33S6NC092753
SCBDG4ZG5NC091098	SCBDZ33S1NC092766
SCBDF33S1NC091142	SCBDG4ZG9NC092769
SCBDX33S5NC091223	SCBDG4ZG6NC092776
SCBDX33S2NC091230	SCBDX33S2NC092779
SCBDF33S7NC091310	SCBDX33S1NC092787
SCBDG4ZG6NC091319	SCBDX33SXNC092822
SCBDX33S2NC091440	SCBDG4ZG8NC092827
SCBDG4ZG3NC091522	SCBDG4ZGXNC092845
SCBDG4ZG0NC091588	SCBDX33S6NC092851
SCBDX33S1NC091770	SCBDG4ZG1NC092863
SCBDX33S4NC091794	SCBDG4ZG2NC092869
SCBDG4ZG9NC091945	SCBDG4ZG4NC092873
SCBDG4ZG3NC092220	SCBDG4ZG5NC092901
SCBDG4ZG7NC092236	SCBDX33S3NC092905
SCBDG4ZG8NC092245	SCBDF33S5NC092908
SCBDG4ZG9NC092254	SCBDZ33S6NC092911
SCBDG4ZG6NC092308	SCBDG4ZG3NC092914
SCBDX33SXNC092335	SCBDX33S5NC092923
SCBDG4ZG5NC092350	SCBDZ33SXNC092930
SCBDG4ZG3NC092363	SCBDZ33S1NC092945
SCBDX33S9NC092391	SCBDG4ZG4NC092968
SCBDX33SXNC092397	SCBDZ33S4NC092972
SCBDG4ZG8NC092410	SCBDG4ZG8NC093024
SCBDG4ZG6NC092423	SCBDG4ZG6NC093037
SCBDG4ZG5NC092431	SCBDG4ZG3NC093044
SCBDX33S7NC092454	SCBDX33S1NC093051
SCBDG4ZG1NC092460	SCBDG4ZG5NC093059
SCBDZ33S5NC092463	SCBDX33S6NC093062
SCBDG4ZG8NC092472	SCBDG4ZG6NC093071
SCBDG4ZG9NC092481	SCBDG4ZG1NC093074
SCBDG4ZG4NC092484	SCBDX33S8NC093077
SCBDX33S0NC092487	SCBDG4ZG7NC093080
SCBDG4ZG5NC092493	SCBDG4ZG2NC093083
SCBDG4ZG0NC092496	SCBDG4ZG7NC093094
SCBDG4ZG6NC092521	SCBDX33S1NC093101
SCBDX33S8NC092527	SCBDX33S2NC093107
SCBDF33SXNC092600	SCBDG4ZG0NC093115
SCBDF33S0NC092606	SCBDG4ZG8NC093119
SCBDG4ZG9NC092609	SCBDG4ZGXNC093123
SCBDG4ZG8NC092620	SCBDG4ZG7NC093127
SCBDG4ZG1NC092636	SCBDF3ZGXNC093135
SCBDX33S8NC092639	SCBDG4ZG1NC093141
SCBDG4ZG8NC092651	SCBDX33S3NC093150
SCBDG4ZG3NC092654	SCBDJ33S2NC093156
SCBDG4ZG9NC092660	SCBDG4ZG5NC093160
SCBDG4ZG5NC092672	SCBDG4ZG0NC093194
SCBDG4ZG0NC092675	SCBDG4ZG3NC093240
SCBDX33S5NC092677	SCBDG4ZGXNC093266
SCBDX33S1NC092692	SCBDZ33S2NC093294
SCBDG4ZG1NC092703	SCBDG4ZG6NC093331
SCBDG4ZG2NC092709	SCBDG4ZGXNC093350
SCBDJ33S3NC092730	SCBDF33S2NC093451
SCBDG4ZG5NC092736	SCBDG4ZG2NC093455
SCBDG4ZG0NC092739	SCBDG4ZGXNC093476
SCBDG4ZGXNC092750	

New Flying Spur V8 Kovomo

SCBBG53S0NC090726	SCBBG6ZG1NC092221	SCBBZ53S4NC092568	SCBBG6ZG7NC092921	SCBBX53S1NC093151
SCBBG53S2NC090730	SCBBZ53S7NC092225	SCBBG53S9NC092572	SCBBZ53S0NC092924	SCBBZ53S2NC093153
SCBBZ53S4NC090738	SCBBX53S0NC092234	SCBBX53S4NC092575	SCBB15ZG1NC092926	SCBBZ53SXNC093157
SCBBG53S0NC090774	SCBBZ53S6NC092247	SCBBG53SXNC092578	SCBB15ZG5NC092928	SCBBZ53S5NC093163
SCBBG53S2NC090792	SCBBG6ZG4NC092262	SCBBZ53S3NC092593	SCBBG6ZGXNC092931	SCBBG6ZG0NC093165
SCBBG53S5NC090804	SCBBZ53S8NC092315	SCBBZ53S2NC092598	SCBBZ53S9NC092937	SCBBZ53S4NC093168
SCBBG53S0NC090824	SCBBZ53S0NC092325	SCBBG53S2NC092607	SCBBZ53S9NC092940	SCBBZ53S4NC093171
SCBBZ53S1NC090874	SCBBG53S7NC092330	SCBBZ53SXNC092610	SCBBZ53SXNC092946	SCBBZ53S1NC093175
SCBBG53S1NC090878	SCBBZ53S7NC092337	SCBBZ53S0NC092616	SCBBZ53S1NC092950	SCBBG53S1NC093179
SCBBG53S6NC090892	SCBBG53S0NC092346	SCBBG53S1NC092646	SCBB15ZG2NC092952	SCBBZ53S7NC093181
SCBBG53S5NC090902	SCBBG53S6NC092349	SCBBG6ZGXNC092668	SCBBZ53S0NC092955	SCBBG6ZG2NC093183
SCBBG53S5NC090947	SCBBG53S4NC092351	SCBBX53SXNC092676	SCBBZ53S4NC092960	SCBBZ53S8NC093187
SCBBG53S3NC090977	SCBBZ53S7NC092354	SCBBZ53S2NC092682	SCBBG6ZG7NC092966	SCBBZ53S1NC093189
SCBBG53S6NC090987	SCBBG6ZG2NC092373	SCBBX53S6NC092691	SCBBG53S0NC092976	SCBBZ53SXNC093191
SCBBZ53S2NC090995	SCBBZ53S8NC092377	SCBBG53S7NC092702	SCBBG6ZG1NC092980	SCBBG6ZG9NC093195
SCBBG53S5NC091001	SCBBZ53S3NC092383	SCBBX53S2NC092705	SCBBG6ZG1NC092994	SCBB15ZG3NC093201
SCBBG53S9NC091017	SCBBX53SXNC092385	SCBBG53S8NC092708	SCBB15ZG2NC093003	SCBB15ZG3NC093219
SCBBG53SXNC091026	SCBBZ53S2NC092388	SCBBZ53S3NC092710	SCBBZ53S2NC093007	SCBBZ53S1NC093239
SCBBX53S3NC091126	SCBBG6ZG2NC092390	SCBBX53S1NC092713	SCBBG6ZG8NC093009	SCBBG6ZG1NC093241
SCBBG53S9NC091146	SCBBG53S7NC092392	SCBBZ53SXNC092719	SCBBG6ZGXNC093013	SCBBG6ZG5NC093243
SCBBG53S8NC091199	SCBBZ53S5NC092398	SCBBX53S2NC092722	SCBBG6ZG3NC093015	SCBB15ZG1NC093249
SCBBG53S9NC091227	SCBBG6ZG5NC092402	SCBBG6ZG2NC092728	SCBB15ZS1NC093023	SCBBX53S5NC093251
SCBBG53S6NC091234	SCBBZ53S7NC092404	SCBBZ53S7NC092743	SCBBZ53SXNC093028	SCBBG6ZG8NC093253
SCBBG53S1NC091240	SCBBG53S6NC092416	SCBBX53S9NC092751	SCBBZ53S1NC093032	SCBBZ53SXNC093255
SCBBG53S7NC091243	SCBBG53S9NC092426	SCBBX53S4NC092754	SCBBZ53SXNC093045	SCBBG6ZG5NC093257
SCBBG53S9NC091261	SCBBG6ZG1NC092428	SCBBZ53S6NC092765	SCBBG6ZG5NC093050	SCBBX53SXNC093259
SCBBG53S0NC091262	SCBBG6ZG7NC092434	SCBBZ53S1NC092768	SCBBG6ZG0NC093053	SCBBG6ZG7NC093261
SCBBG53S6NC091279	SCBBG6ZG2NC092440	SCBBZ53S5NC092773	SCBBZ53S2NC093055	SCBBZ53S2NC093265
SCBBG53S4NC091300	SCBBG6ZG4NC092455	SCBBZ53SXNC092784	SCBBX53S9NC093057	SCBBX53S2NC093272
SCBBZ53S7NC091317	SCBBG6ZGXNC092461	SCBBZ53SXNC092817	SCBBG6ZG3NC093063	SCBBX53SXNC093276
SCBBG53S0NC091326	SCBBZ53S3NC092464	SCBBG53S6NC092819	SCBBG6ZG9NC093066	SCBBZ53S2NC093301
SCBBG53S7NC091341	SCBBG53S1NC092467	SCBBG6ZG0NC092825	SCBBG6ZG4NC093069	SCBBZ53S0NC093314
SCBBG53S2NC091344	SCBBX53S7NC092473	SCBBZ53S2NC092830	SCBBZ53S2NC093072	SCBBG6ZG0NC093330
SCBBG53S3NC091353	SCBBG6ZG7NC092479	SCBBG53SXNC092838	SCBBG6ZGXNC093075	SCBBX53S7NC093333
SCBBX53S8NC091400	SCBBX53SXNC092483	SCBB15ZSXNC092842	SCBBZ53S3NC093078	SCBB15ZG2NC093440
SCBBX53S1NC091402	SCBBG6ZGXNC092492	SCBBZ53S2NC092844	SCBBZ53S9NC093084	SCBBZ53S6NC093446
SCBBG53S6NC091413	SCBBG6ZG5NC092495	SCBB15ZG3NC092846	SCBBX53S7NC093087	SCBBG53S2NC093448
SCBBG53S1NC091416	SCBBZ53S5NC092501	SCBBG53S2NC092848	SCBBG53S0NC093089	SCBBG6ZG0NC093456
SCBBG53S0NC091438	SCBBX53S1NC092503	SCBBX53S0NC092850	SCBBZ53S6NC093091	SCBBZ53S4NC093462
SCBBG53S0NC091441	SCBBG6ZG4NC092505	SCBBG6ZG3NC092852	SCBBZ53SXNC093093	SCBBG6ZG7NC093468
SCBBG53SXNC091463	SCBBZ53SXNC092509	SCBBZ53S9NC092856	SCBBZ53S3NC093095	SCBB15ZG4NC093472
SCBBX53S3NC091580	SCBBZ53S1NC092513	SCBBZ53S2NC092858	SCBBX53S1NC093098	SCBBZ53S9NC093473
SCBBG53S2NC091599	SCBBZ53S2NC092519	SCBBG53S3NC092860	SCBBZ53S3NC093100	SCBBG6ZG4NC093475
SCBBG6ZGXNC091729	SCBBZ53S8NC092525	SCBBG6ZG7NC092871	SCBBZ53S0NC093104	SCBBG6ZG8NC093477
SCBBG53SXNC091737	SCBBG53S6NC092531	SCBBG6ZG2NC092874	SCBB15ZG1NC093106	
SCBBX53S6NC091752	SCBBX53S3NC092535	SCBBG6ZG1NC092882	SCBBX53S0NC093108	
SCBBG6ZG6NC091789	SCBBG6ZGXNC092539	SCBBZ53S3NC092884	SCBBG6ZG5NC093114	
SCBBZ53S4NC091792	SCBBG6ZG5NC092545	SCBBZ53S9NC092890	SCBBZ53S7NC093116	
SCBBG6ZG9NC091799	SCBBX53S1NC092548	SCBBZ53S2NC092892	SCBBG6ZG0NC093120	
SCBBZ53S5NC091803	SCBBZ53S7NC092550	SCBBG6ZGXNC092895	SCBB15ZG7NC093126	
SCBBG53S9NC091809	SCBBZ53S0NC092552	SCBBZ53S3NC092898	SCBBG6ZG5NC093128	
SCBBG53S4NC091815	SCBBG53S7NC092554	SCBB15ZG5NC092900	SCBBZ53S1NC093130	
SCBBG53S0NC091908	SCBBZ53S8NC092556	SCBBZ53S3NC092903	SCBBZ53S2NC093136	
SCBBG53S6NC091914	SCBBZ53S1NC092558	SCBBG6ZG0NC092906	SCBBZ53S4NC093140	
SCBBZ53S3NC091928	SCBBZ53SXNC092560	SCBBG6ZG1NC092915	SCBBX53S6NC093145	
SCBBG6ZG0NC092209	SCBBZ53S3NC092562	SCBBZ53S5NC092918	SCBBZ53S0NC093149	

Engine and automatic transmission hydraulic lifting table - to prepare

General Information

The information in this procedure is for setting up the Hydraulic lifting table -VAS 6131- for engine and transmission removal from the vehicle ONLY.

 **WARNIN
G**

For safety reasons refer to the operating manual supplied with the table BEFORE using the hydraulic lifting table.

 **WARNIN
G**

For safety reasons suitably secure the engine and transmission to the Hydraulic lifting table - VAS 6131-

This document shows the procedures for setting up the Hydraulic lifting table -VAS 6131-.

This document does not cover the steps required to prepare the car prior to raising the engine and automatic transmission support pillars into place, refer to the relevant engine and automatic transmission remove and fit

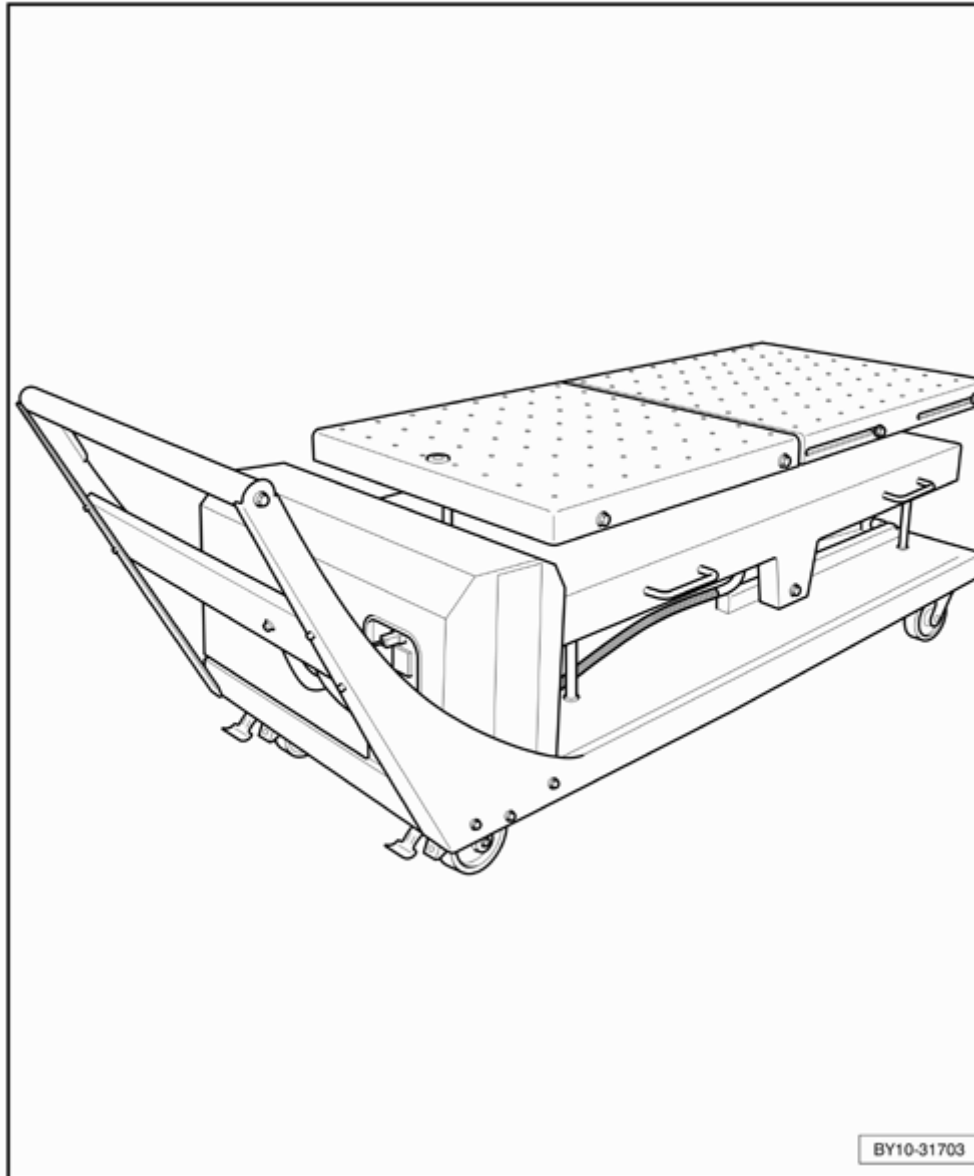

procedure before
setting up the
pillars.

Engine and automatic transmission
hydraulic lifting table - To set up

Check that the lifting table bed is
level by using the spirit level -

- arrow- at the front of the table.
Adjust as necessary using the
control box.

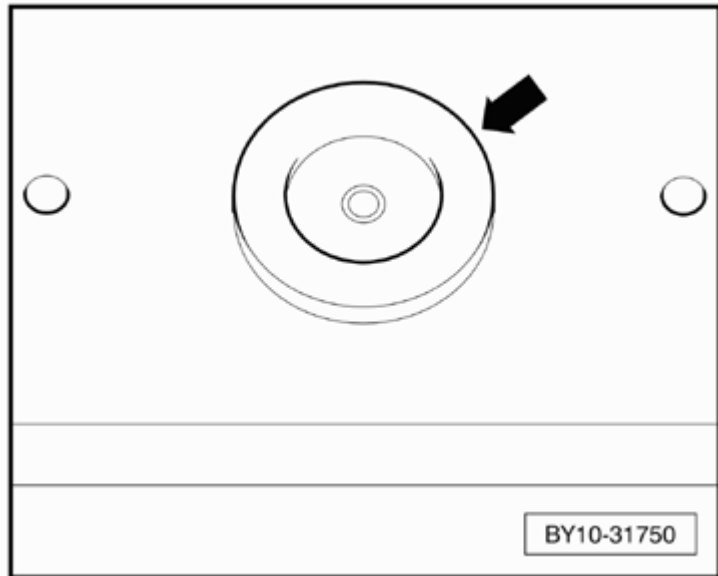

- Allow the table bed to float, release
the locking levers -arrow- on the
side of the bed.

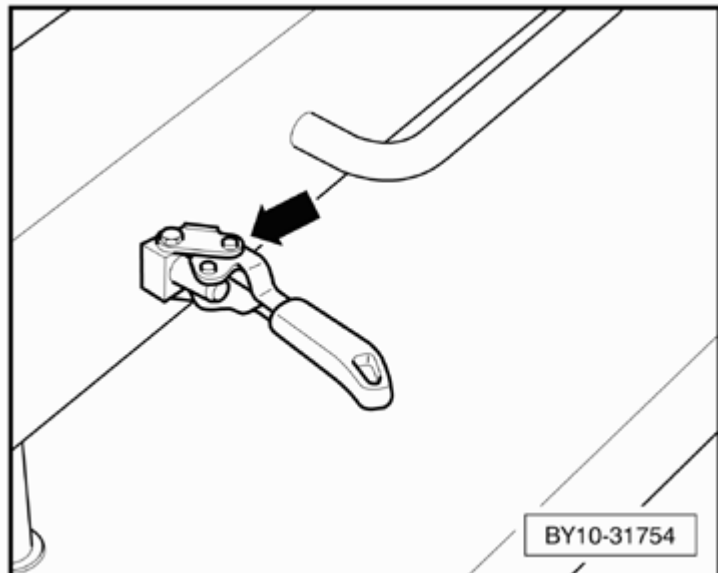

The Hydraulic lifting table -VAS 6131- requires a 3 phase electricity supply and armoured lead, to be sourced from a local qualified supplier.

- Check the hydraulic oil level, the tank is situated at the front of the table under the blue housing.

⚠ WARNING

The following procedure should only be carried out by qualified personnel:

- Briefly test the table, refer to the "Engine and automatic transmission hydraulic lifting table controls" section below.
- Using the controls, lift the table. If the table rises then the operating voltage has the correct rotating field.
- If the table fails to operate or the motor turns in the wrong direction, disconnect from the electricity supply from the wall socket, open the socket, swap connections L1 and L2. This reverses the direction of the motor.

Engine and automatic transmission hydraulic lifting table controls

The table controls are as follows:

- ◆ Vertical lift = Hold button -1- and press button -4-.
- ◆ Fast vertical lift = Hold button -2- and press button -4-.
- ◆ Vertical descent = Hold button -1- and press button -3-.
- ◆ Fast vertical descent = Hold button -2- and press button -3-.
- ◆ Lift the rear end (handle end) of the table = Press button -5-.
- ◆ Lift the front of the table = Press button -6-.
- ◆ Lift the left hand side of the table = Press button -7-.
- ◆ Lift the right hand side of the table = Press button -8-.

Engine, automatic transmission and front sub frame support pillars - To set up

Continental GT/GTC 4.0L V8

Special tools and workshop equipment required

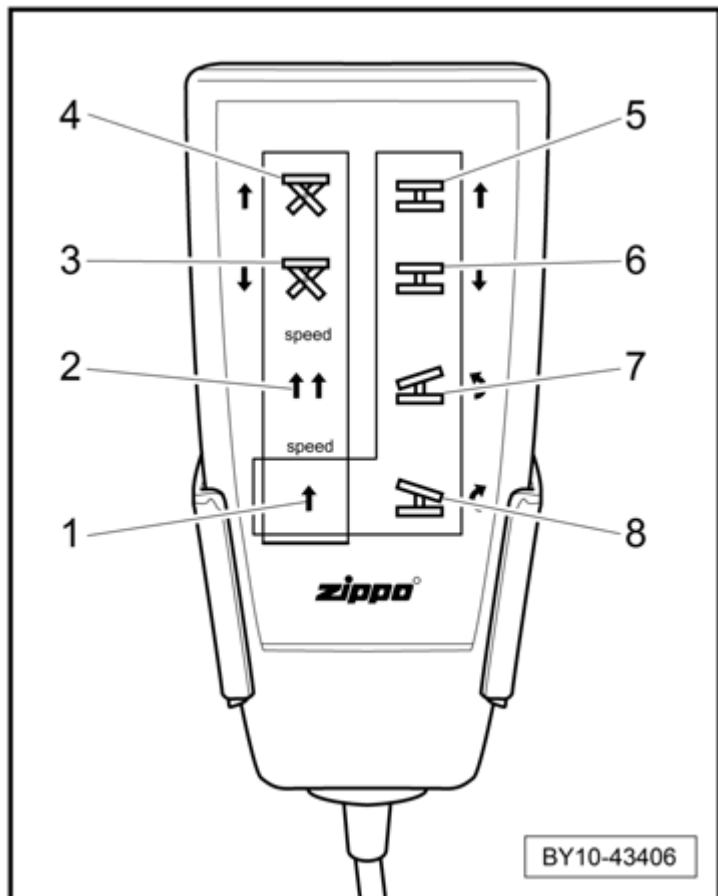
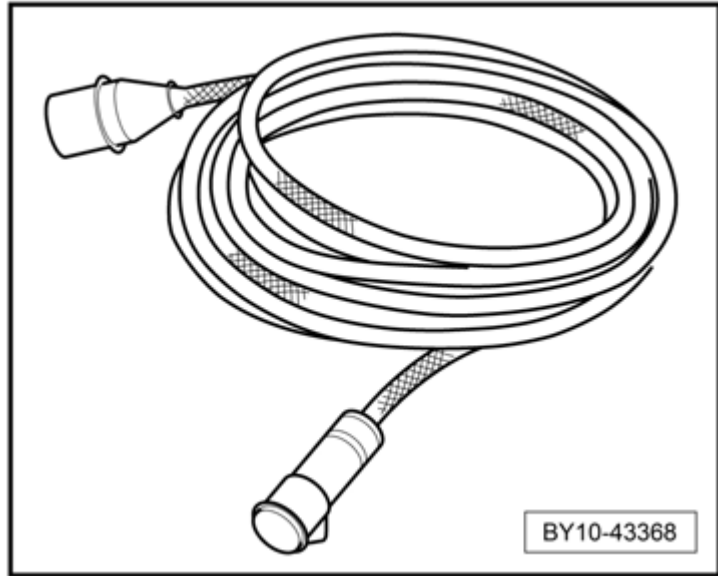

- ◆ Hydraulic lifting table - VAS 6131-

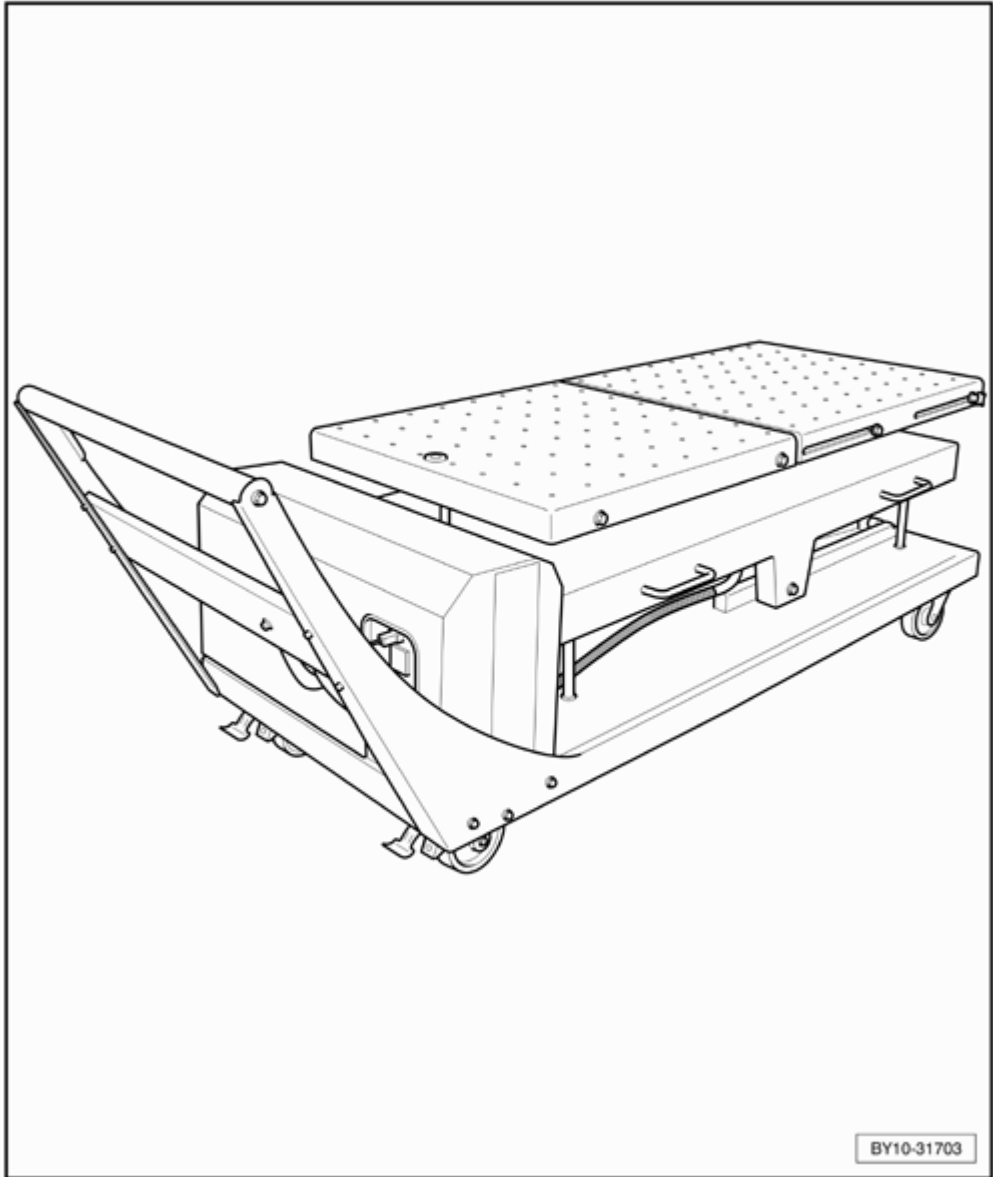

BY10-31703

- ◆ Support set -VAS 6131/10-

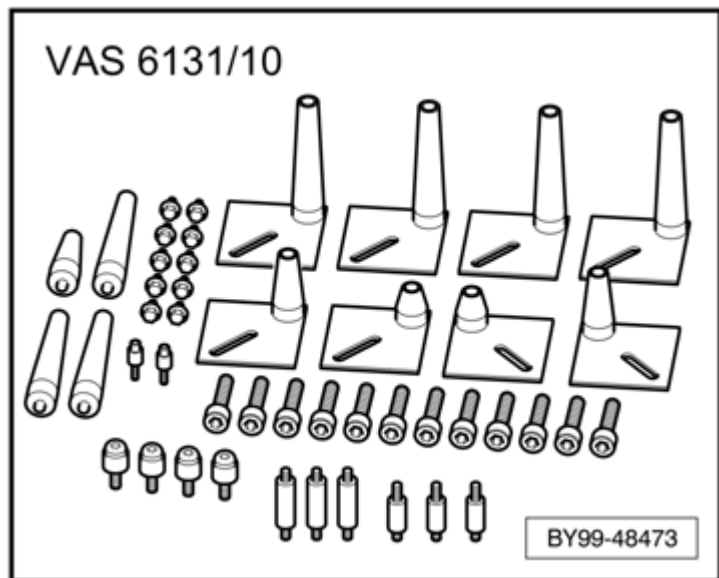

BY99-48473

- ◆ Support set -VAS 6131/13-

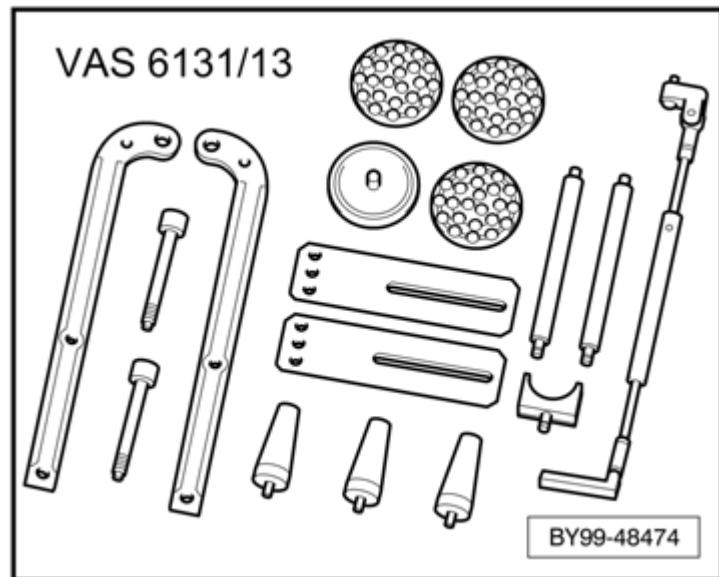

- ◆ Engine support pin -WT 10368- (2 off to support transmission)

 **Caution**

When raised, the engine and automatic support pillars are located in close proximity to hoses and pipework. Ensure that all pillars are fully located in their locating points prior to supporting the sub frame, engine and automatic transmission. Failure to do so may result in damage to the underside of the car.

 **Note**

It is recommended that all procedures are carried out with the help of an assistant to ensure that ALL pillars are fully located in their locating points prior to supporting the sub frame, engine and automatic transmission.

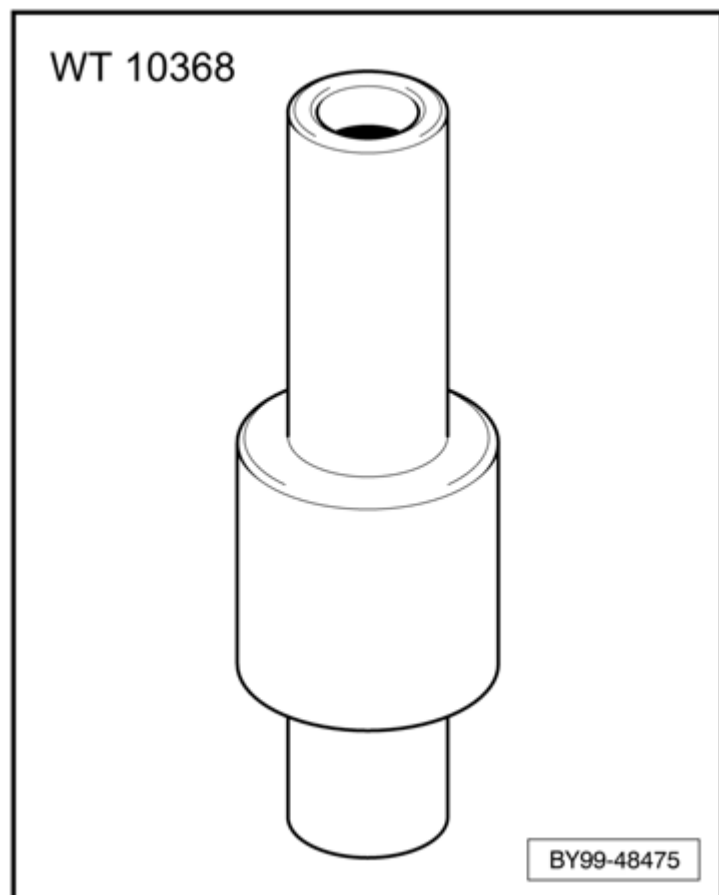

– Attach the tool elements to the Hydraulic lifting table -VAS 6131- as shown:

B2 - Engine/subframe - Front left

Plate -VAS 6131/10-1-

Support -VAS 6131/10-4-

Threaded support -VAS 6131/10-5-

Support pin -VAS 6131/10-10-

G2 - Engine/subframe - Front right

Plate -VAS 6131/10-1-

Support -VAS 6131/10-4-

Threaded support -VAS 6131/10-5-

Support pin -VAS 6131/10-13-

B6 - Engine/subframe - Rear left

Plate -VAS 6131/10-1-

Support -VAS 6131/10-4-

Threaded support -VAS 6131/10-5-

Pad -VAS 6131/13-02-

G6 - Engine/subframe - Rear right

Plate -VAS 6131/10-1-

Support -VAS 6131/10-4-

Threaded support -VAS 6131/10-5-

Pad -VAS 6131/13-02-

F16 - Transmission body mount - Rear centre right

Plate -VAS 6131/10-1-

Support -VAS 6131/10-4-

Threaded support -VAS 6131/10-5-

Pad -VAS 6131/13-02-

C16 - Transmission body mount - Rear centre Left

Plate -VAS 6131/10-1-

Support -VAS 6131/10-4-

Threaded support -VAS 6131/10-5-

Pad -VAS 6131/13-02-

Positioning the support pillars

Raise the Hydraulic lifting table -VAS 6131- until all supports positioned in close proximity to the points as shown below:

– Engine/subframe - Front right - Position G2

Into the front right support boss.

– Engine/subframe - Front left - Position B2

Into the front left support boss.

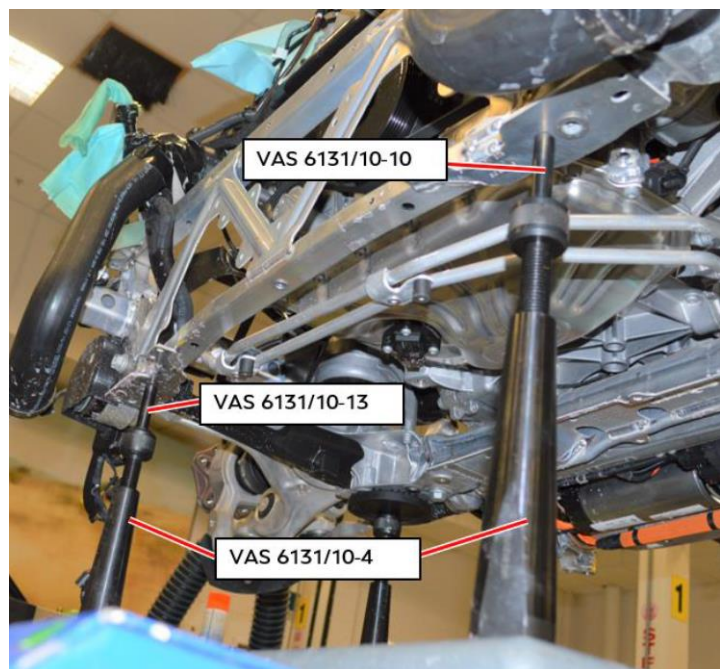
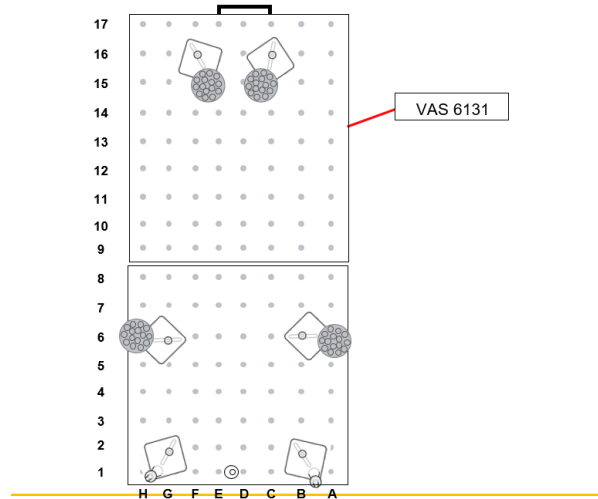

- Engine/subframe - Rear left - Positions B6
As viewed from the front of the vehicle.
Into the rear right support boss.

- Engine/subframe - Rear Right - Position G6
Into the rear left support boss.
As viewed from the front of the vehicle.



Note

RH side shown, LH side symmetrically opposite.

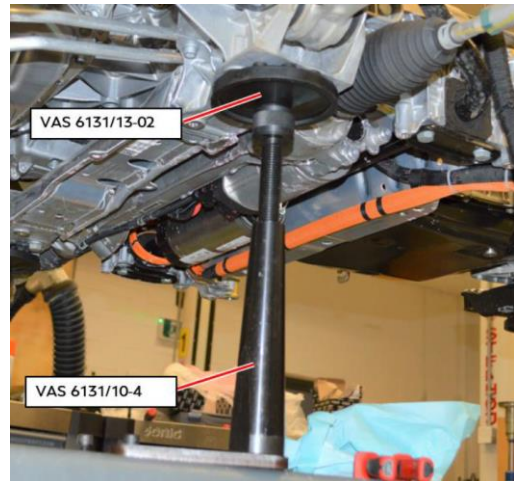

- Transmission body mount- Rear Centre right - Position F16
Rubber pad supporting the transmission mount

- Transmission body mount- Centre Rear left - Position C16
Rubber pad supporting the transmission mount



Note

LH side shown, RH side symmetrically opposite.

Wind all supports upwards until they are located but not fully supporting the sub frame, engine and automatic transmission assembly.

- Slowly raise the table to support the engine, sub frame and automatic transmission.

After conformation that the engine, sub frame and automatic transmission are correctly supported, refer back to the step Lowering the engine and automatic transmission

- assembly in section "Engine and automatic transmission - To remove and fit".

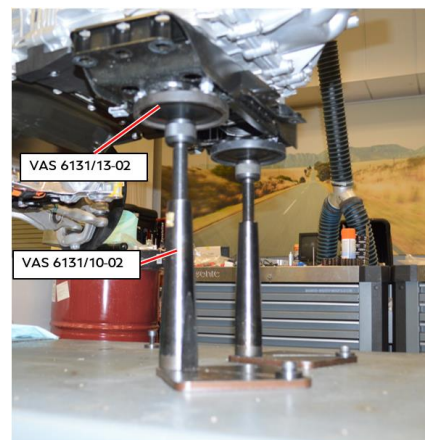

→ Rep.-Gr.10

1. Install valve springs:

Special tools and workshop equipment required

- ◆ Guide plate -VAS 5161A/38-
- ◆ Removal and installation device for valve keys -VAS 5161A-
- ◆ Valve stem seal puller -3364-
- ◆ Press-on tool -3365-



Note

In the Guide plate -VAS 5161A/38- -1- there are four bore holes -a, b, c, d- for mounting on the cylinder head. Depending on the installation situation, observe the use of the bores and secure the Guide plate -VAS 5161A/38- with the supplied screws, M5x40 -2-.

- ◆ -E- Intake side
- ◆ -A- Outlet side

Installation

- Insert NEW valve springs and valve-spring plates in their original position. Observe installation positions.
- Install valve keys.
- Insert assembly cartridge -VAS 5161/8A- -4- into the Guide plate -VAS 5161A/38-.
- Press pressure fork -VAS 5161/2- -1- down, pull knurled screw -arrow- on the assembly cartridge -VAS 5161/8A- -4- upwards by turning it back and forth, thereby inserting the valve collets.
- Relieve pressure on the pressure fork -VAS 5161/2- -1- whilst pulling on the knurled screw.
- Repeat the procedure on each valve.
- When all valves are secured again, disconnect the compressed air connection and unscrew hose adapter -VAS 5161A/35-.
- Do the same on the other cylinders.

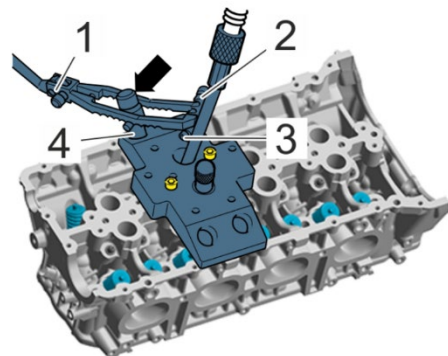
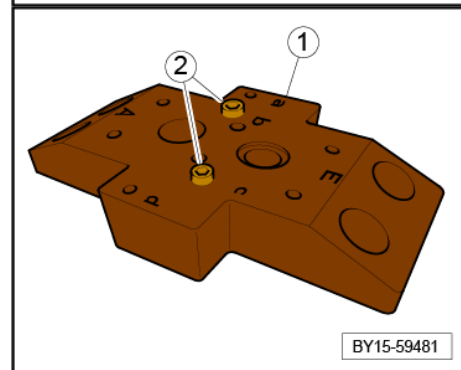

2. Install spark plugs:

Special tools and workshop equipment required

Spark plug socket (14 mm) commercially available.

Installation

Installation is the reverse of removal procedure, noting the following:

- Torque tighten each spark plug to 23 Nm.



WARNING

Always fit a complete set of spark plugs of the same specification.

3. Install valve lifters (hydraulic tappets):

Installation

- Fit hydraulic tappet -2- on valve lever -3-.
- Position hydraulic tappet -2- and safety clip -1- on valve lever -3-.
- Insert hydraulic tappet -2- and hook safety clip -1- into valve lever -3-. Check that the safety clip -1- is fitted correctly.

- Fit hydraulic tappet -1- and valve lever -2-.
- Lightly lubricate the hydraulic tappet -1- and valve lever -2- with engine oil (0W-40).

- Insert hydraulic tappet -1- with the valve lever -2- into the cylinder head together.
- Position the pressure face of the valve lever -2- on the valve pressure face.

- After you have installed all hydraulic tappets and valve levers, check that they are fitted correctly.
- In particular, check that the safety clip is fitted correctly and that the pressure faces of the valve lever and valve are positioned correctly.

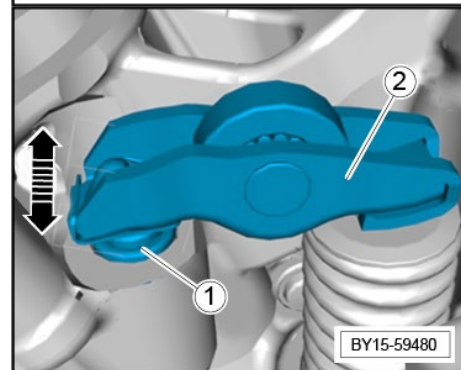
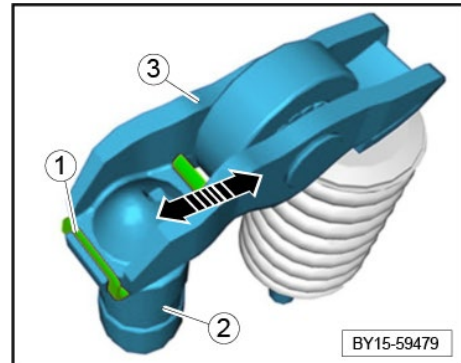

4. Install cylinder head covers:

The following procedure covers both bank 1 and bank 2 camshaft covers.



Note

Cylinder heads are labelled Bank 1 (RHS) and Bank 2 (LHS) as viewed from the driver's seat.

Special tools and workshop equipment required

- ◆ Camshaft clamp kit -T40331-

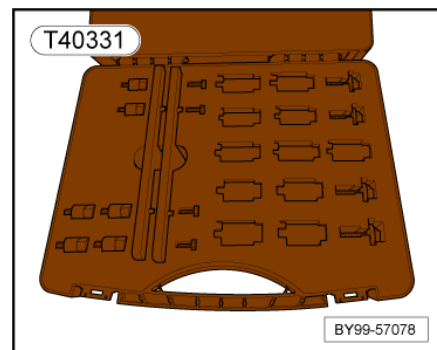

- ◆ Locating pins -T40116-

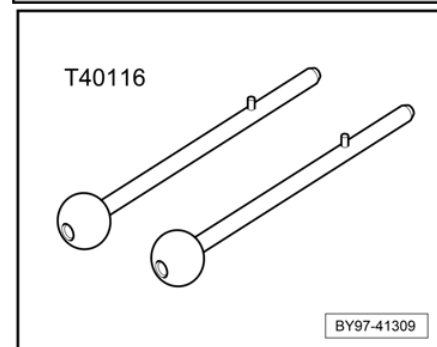

Installation

Installation is the reverse of removal, noting the following.



Note

The Camshaft clamp -T40331- must be fitted before removal and installation.

→ Rep.-Gr.15



Note

Fitting and sealing components using liquid sealant.

- ◆ Clean sealing faces to remove all traces of residual sealant.

- ◆ Sealing faces must be free of grease and oil.
- ◆ Clean sealing faces with primer Loctite -7515-.
- ◆ Use liquid sealant Loctite -5970-BM-.

i Note

Before fitting the cylinder head cover, check that the rocker arms are aligned correctly.

- Apply liquid sealant Loctite -5970-BM- -1- on the cylinder head.

i Note

Install the cylinder head cover within five minutes of applying the liquid sealant.

- Fit and align cylinder head cover -1- on the cylinder head using Locating pins -T40116- -2-.

- Fit cylinder head cover.

i Note

Top image – Bank 1 (RHS)

Bottom image – Bank 2 (LHS)

- Fit screws on the cylinder head cover uniformly and tighten according to the specified tightening sequence.

Torque tightening: 9 Nm

- Locating pins -T40116- must now be pulled off.
- Close off bearing tunnels with rubber caps. Exception: Left intake side with brake booster vacuum pump.

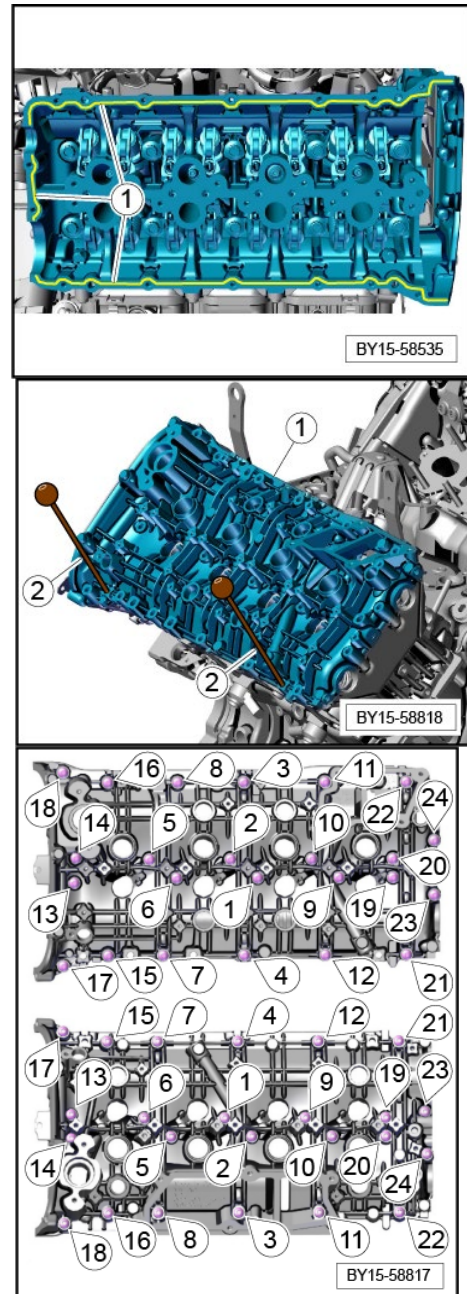

5. Install camshaft actuators (includes setting timing):

The camshaft actuators are located at the rear of cylinder banks 1 and 2, behind the upper chain housing covers.

WARNING

Before commencing work on and around the engine, ensure that it has cooled sufficiently, failure to do so may cause injury to personnel.

Avoid prolonged and repeated contact with oils and fluids etc.

- ◆ Always protect the skin with impervious gloves.
- ◆ Always wear suitable eye protection.

Caution

Suitably blank open ports to prevent the ingress of dirt, moisture and foreign objects into the engine. Failure to do so may cause irreparable damage to the engine.

Special tools and workshop equipment required

- ◆ Counter hold tool -T90001- (not illustrated)
- ◆ Ring wrench insert, a/f 41 -VAS 261 001- (not illustrated)
- ◆ Camshaft clamp -T40331-

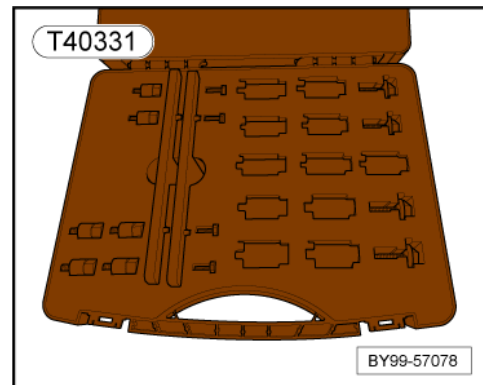

- ◆ Socket E24 -T90000- (not illustrated)
- ◆ Locking pin -T03006-
- ◆ Hook wrench -VAS 261 005- (not illustrated)
- ◆ Counterhold tool -T90002- (not illustrated)
- ◆ Vehicle tester

Component overview

Camshaft control

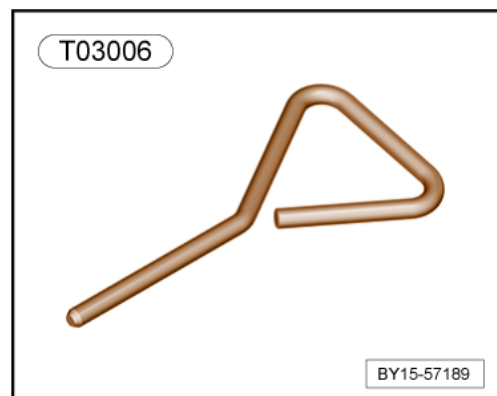

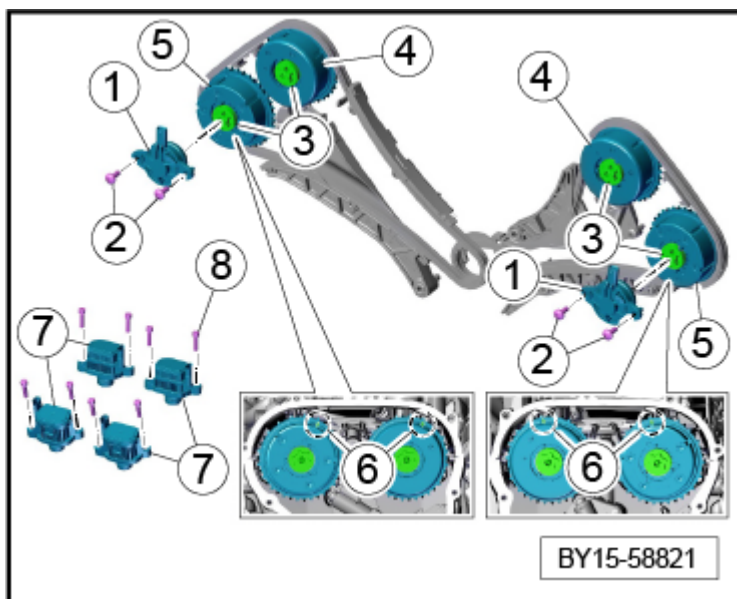

1 - Actuator for camshaft controller

2 - Screws, M6 x 16

Tightening torque: 9 Nm

3 - Central screw for camshaft controller

- ◆ Replace O-ring
- ◆ Initial tightening: 27 Nm
- ◆ Final tightening: 30 Nm +35°

4 - Actuator for outlet camshaft

5 - Actuator for intake camshaft

6 - Installation marking

7 - Valve lift adjustment

8 - Screw, M5 x 20

Tightening torque: 5 Nm

Tightening sequence for central screw for camshaft controller
(item -3-)

Result:	Cylinder bank:	Camshaft:
1.	Bank 2	Outlet
2.	Bank 2	Intake
3.	Bank 1	Intake
4.	Bank 1	Outlet

Installing camshaft actuators – setting the timing

Note

No TDC markings on cylinder head cover.

● In the event that there are no TDC markings on the cylinder head covers, raise a DISS query with Aftersales technical support.

Note

Camshaft actuator must not be disassembled!

Friction plate in camshaft actuator

- ◆ The camshaft actuator must never be disassembled.
- ◆ To replace the friction plate -1-, lever it out carefully using a small slotted screwdriver -2-.

– Check whether the crankshaft, the camshafts and the chain tensioners are fixed.

– Fit new friction plates between the camshaft actuators and camshaft stub.

– Allocate actuators to the camshafts. The actuator with the black surface is for the outlet side.

Distinguishing features of actuators

- 1- Actuator for intake camshaft
- 2- Actuator for exhaust camshaft
- 3- TDC markings

– Position the actuators on the camshafts and fit timing chain. Make sure that the markings on the actuators -1- match the cylinder head covers -2-.

Note

If there are no markings -2- on the cylinder head cover, raise a DISS query with Aftersales technical support.

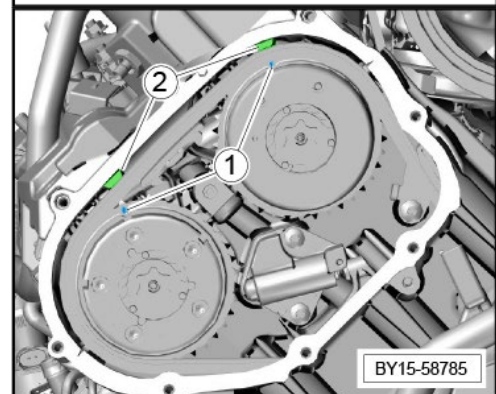
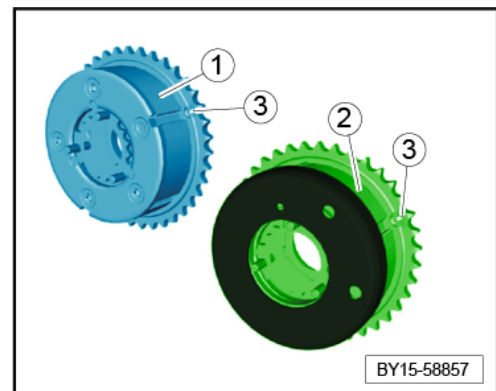
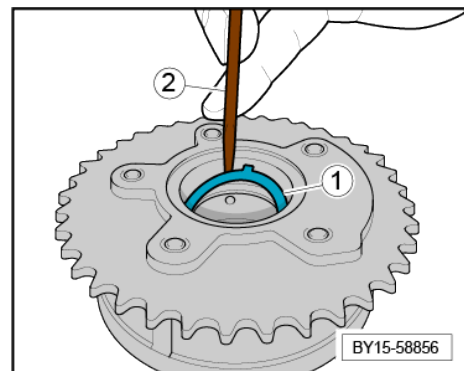

- Replace O-rings -1- on the central valves -2-.
- Lever out old O-ring -1- using a plastic wedge and dispose of it.
- Coat groove on central valve and new O-ring with oil.
- Carefully slide O-ring over the thread and shoulder -3- of the central valve and press it on using a plastic wedge.
- Do not use sharp-edged tools, such as a screwdriver.
- Never mask the thread with tape.
- Remove lock on the chain tensioner -3-.

 **WARNING**

If the tensioner pin is removed without chain guide lever in place, the piston & spring may fly out! (depending on version fitted).

- Screw in central valves.
- Pre-tension the timing chain and pre-tighten central valves.

 **Caution**

Observe specified tightening sequence!

- 1. Outlet, cylinder bank 2
- 2. Intake, cylinder bank 2
- 3. Intake, cylinder bank 1
- 4. Outlet, cylinder bank 1

Use Hook wrench -VAS 261 005- -1- to pre-tension the actuators anti-clockwise and use Socket E24 -T90000- -2- and a torque wrench -3- to pre-tighten the central valves.

Initial tightening: 27 Nm.

- Remove all staking tools.
- Camshaft clamp -T40331- and adapter can now be removed.

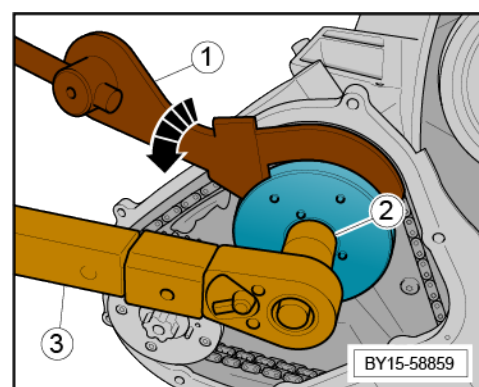
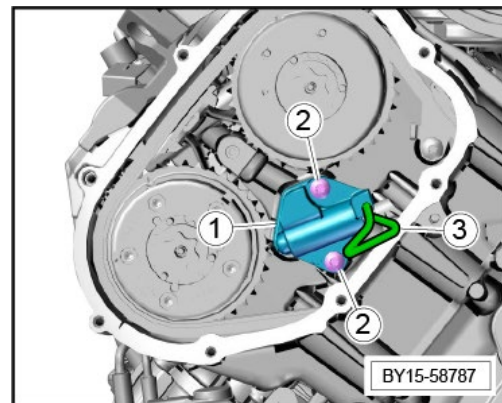
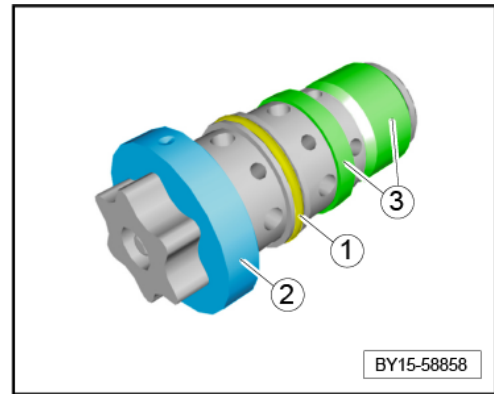

- The tool securing the crankshaft at the front of the engine can now be removed.

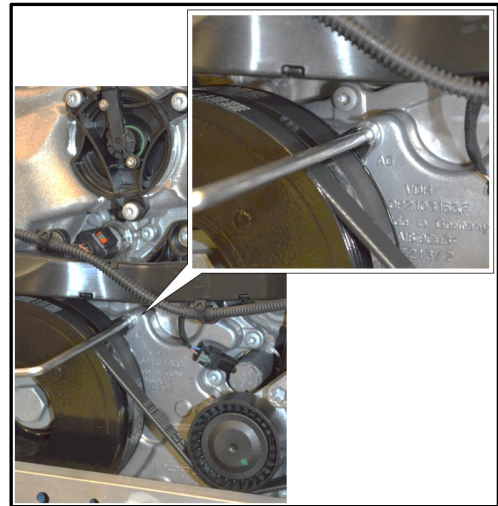

- Secure central valves. Counterhold tool -T90001- -1- and Counterhold tool - T90002- -2- must be fitted on the actuators. To do this, turn the engine clockwise until the tool engages.
- Tighten central valves using Socket E24 -T90000- -3-.
- ◆ Final tightening: 30 Nm.
- ◆ Final tightening: + 35°.

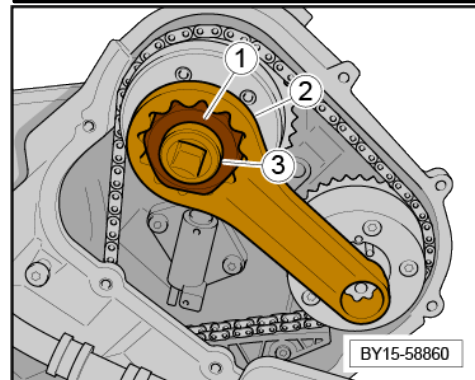

Subsequent work

- Fit change-over valve for water pump -3- and holder.
- Vacuum System for reference:
- 1- Brake booster vacuum pump
 - 2- Vacuum line
 - 3- Electric change-over valve for water pump
 - 4- Control valve for boost pressure control, cylinders 1 to 4
 - 5- Control valve for boost pressure control, cylinders 5 to 8
 - 6- Brake booster connection
 - 7- Vacuum unit connection

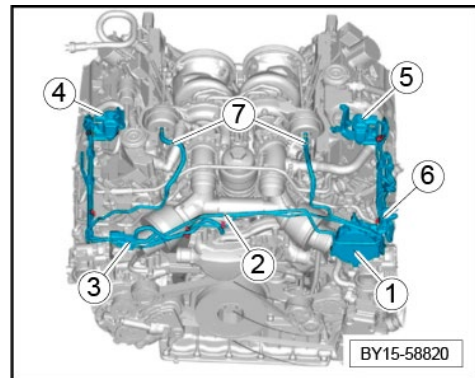

- Secure tank ventilation sensor (USA) or dummy (cylinders 1-4) -1-.
- Position tank ventilation sensor (USA) or dummy -1- together with vent line -5- on holder -4-.
- Screw in and tighten fastening screw -2-.
- Plug in electric plug connection -3-.
- For bank 2 only, fit the dipstick.

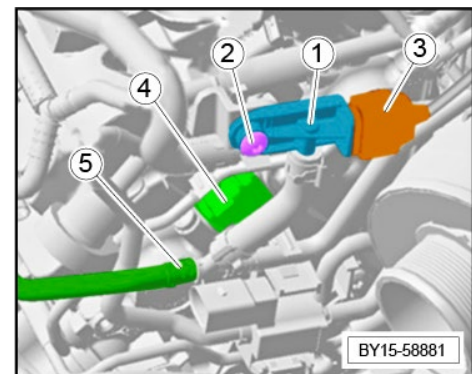

6. Install pressure pipes:

Special tools and workshop equipment required

- ◆ Hose clip pliers -ASE 451 492 00 000-.

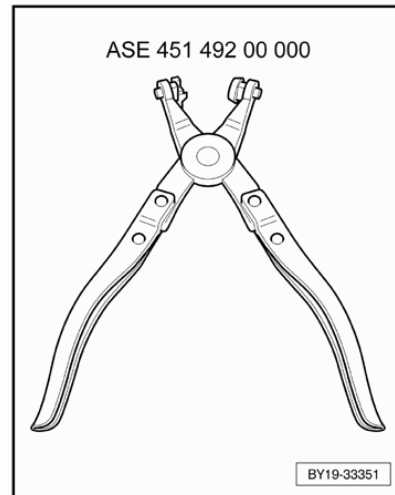

Installation

Installation is the reverse of removal procedure, noting the following.

- RENEW any "O-rings".
- Refit all previously removed components.
- Torque tighten all fixings as per removal.

–

→ Rep.-Gr.00

7. Install mechanical vacuum pump:

Installation

Installation is the reverse of removal procedure, noting the following.

- Ensure the mating faces between the vacuum pump and cylinder head are clean and free of dirt and residual oil.
- RENEW the "O-ring" -1- for the vacuum pump.

– Using NEW fixings -3-, secure the vacuum pump. Torque tighten in the sequence shown:

- ◆ Stage 1 — Hand tighten
- ◆ Stage 2 — 5 Nm
- ◆ Stage 3 – 9 Nm

Drive gear

– Ensure that the drive gear in the camshaft -arrowed- aligns with the slot in the vacuum pump -arrowed-.

Camshaft keyway

Drive gear in vacuum pump

– Ensure all wiring and hoses are clipped in their original positions.

Torque tighten all remaining fixings.

– → Rep.-Gr.00

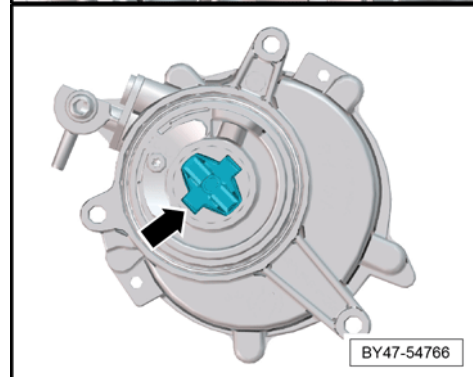
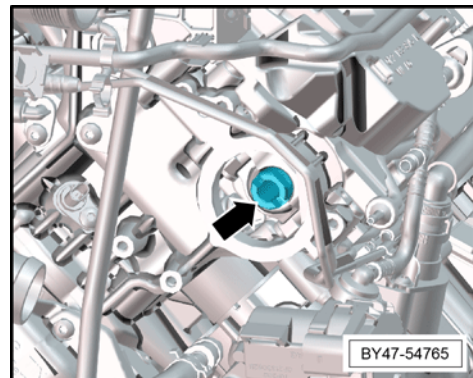
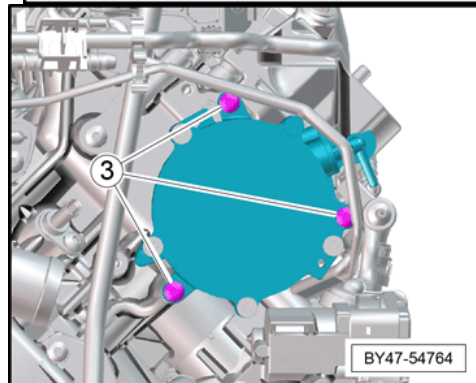
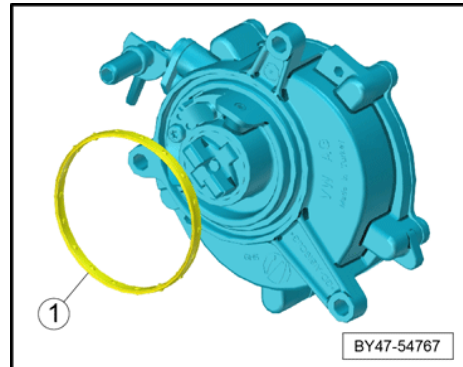

8. Install fuel injectors:

Special tools and workshop equipment required

Tool set for TSI engines -T10133-

Dismantling the injector

- Pull the O-ring -3- and spacer ring -2- off from the injector -1- and DISCARD.
- Unclip the sealing element -5- and DISCARD.
Carefully remove the old combustion chamber sealing ring -6- and DISCARD. To do so, very carefully cut the sealing ring with a knife or prise off with a suitable non-metallic tool.



Note

Take care not to damage the sealing groove on the injector. The injector must be renewed if the groove is damaged.

Installation

Installation is the reverse of removal procedure, noting the following.



Note

Renew sealing element -5-, combustion chamber ring -6-, seal and O-ring-3- and backing ring -2-.

Renew spacer ring if damaged.

Lubricate O-rings of injectors lightly with clean engine oil.

- Clean the bore in cylinder head with Nylon cylinder brush -T10133/4-.

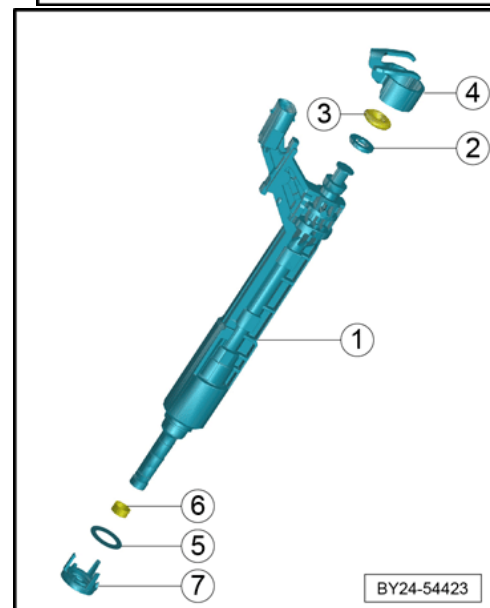
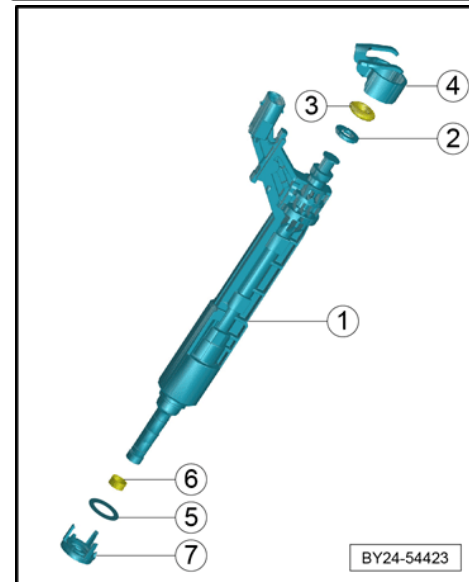
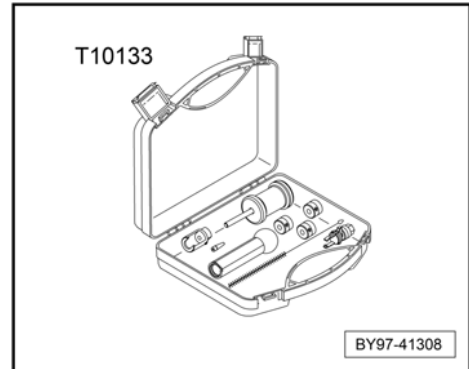

– Fit Assembly cone -T10133/5- with a NEW combustion chamber sealing ring -1- onto the injector -2-.

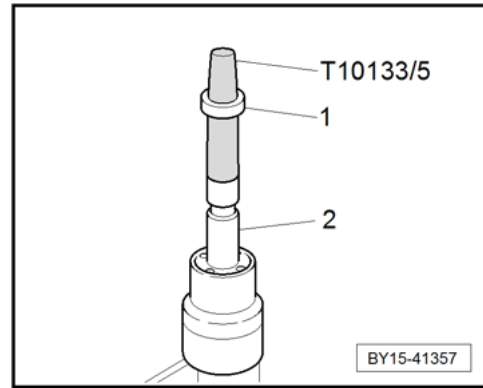

Using the Assembly sleeve -T10133/6- push the combustion chamber sealing ring onto Assembly cone -T10133/5- as far as it will go.

– Turn around Assembly sleeve -T10133/6- and slide the combustion chamber sealing ring into the groove of the injector.

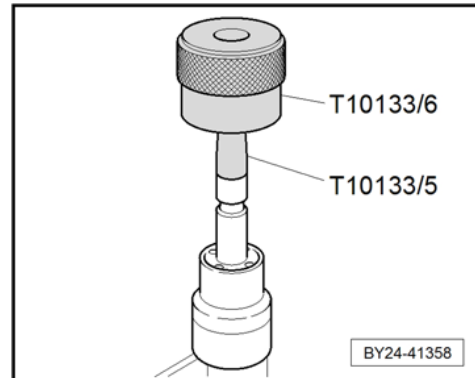

i Note

The combustion chamber sealing ring is widened when it is pushed onto the injector. After pushing it on, it therefore has to be compressed again. This is done in four stages, as described below.

- ◆ Push Calibration sleeve -T10133/7- onto the injector as far as it will go and simultaneously turn it 180°.
- ◆ Pull Calibration sleeve -T10133/7- off again by turning in the opposite direction.
- ◆ Push Calibration sleeve -T10133/8- onto the injector as far as it will go and simultaneously turn it 180°.
- ◆ Pull Calibration sleeve -T10133/8- off again by turning in the opposite direction.

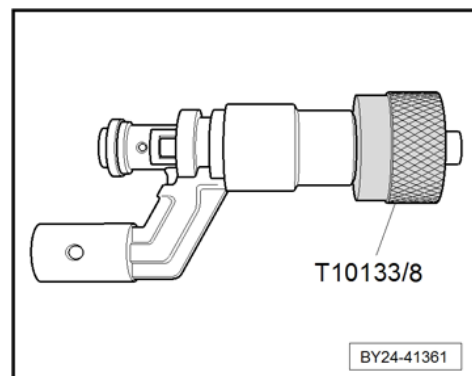
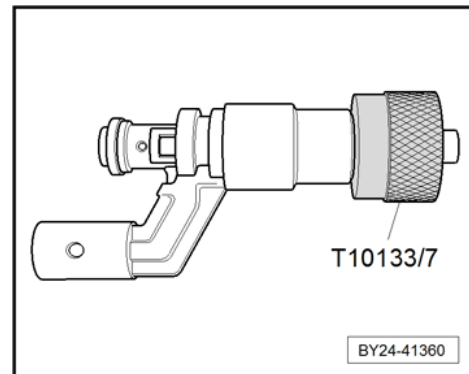

- Fit the parts from the injector repair kit onto the injector - 1-:

To ease injector installation into the fuel rail, lubricate

- new O-ring lightly with clean engine oil before installing it.



Note

The combustion chamber ring seal -6- must NOT be lubricated.



Caution

Use Press tool -T10133/9-, push the injector into the cylinder head as far as it will go. DO NOT push the injector in by force.

- Replace all previously discarded parts.
- Replace low pressure injector O rings and the fuel supply pipes and clamps.

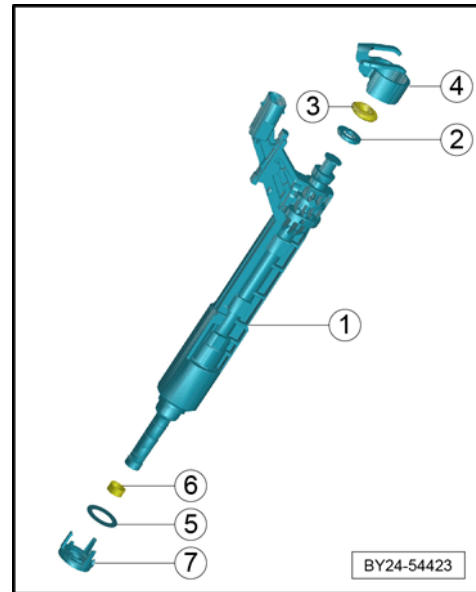

9. Install cylinder deactivation solenoids:

Installation

Installation is the reverse of removal procedure, noting the following.

- RENEW the "O-rings" on the cylinder deactivation solenoids.
- Before refitting the solenoids, apply a small amount of CLEAN engine oil to the "O-ring".
- Torque tighten all fixings as per removal.
- [→ Rep.-Gr.00](#)

10. Install fuel rails:

The installation of the fuel rails is symmetrically the same on both banks of the engine unless stated otherwise.

Installation

Installation is the reverse of removal procedure, noting the following.

- Torque tighten the fixings in the sequence shown.
- ◆ Stage 1 — Hand tight.
- ◆ Stage 2 — 7 Nm.
- ◆ Stage 3 — 10 Nm.

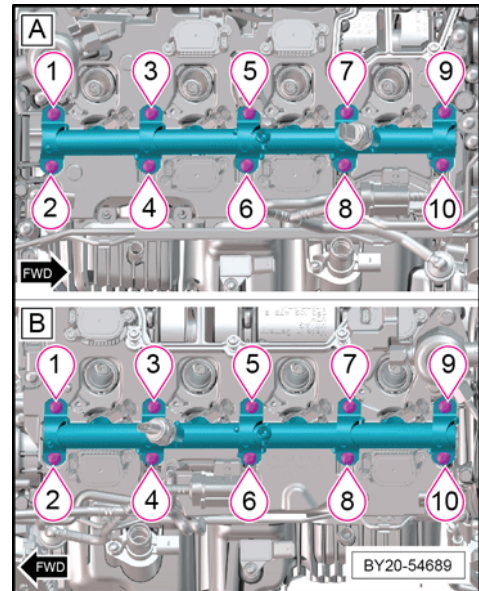

11. Install high pressure fuel pumps:

The installation of the high pressure fuel pump is the same for both sides of the engine unless stated otherwise.

Special tools and workshop equipment required

- ◆ Torque wrench -VAG 1331 -

- ◆ Tool insert AF 17 -VAG 1331/6-

Consumables

Microgleit DF977S lubricant (refer to electronic parts catalogue "ETKA")

Installation

Installation is the reverse of removal procedure, noting the following.

- Lightly lubricate roller tappet with engine oil (0W-40) and insert it so that the lug -arrow A- slides into the guide notch. -arrow B-

- Using a suitable "breaker" bar, rotate the engine in the direction of normal engine rotation and at the same time press the roller tappet into the camshaft cover until it reaches its lowest point.

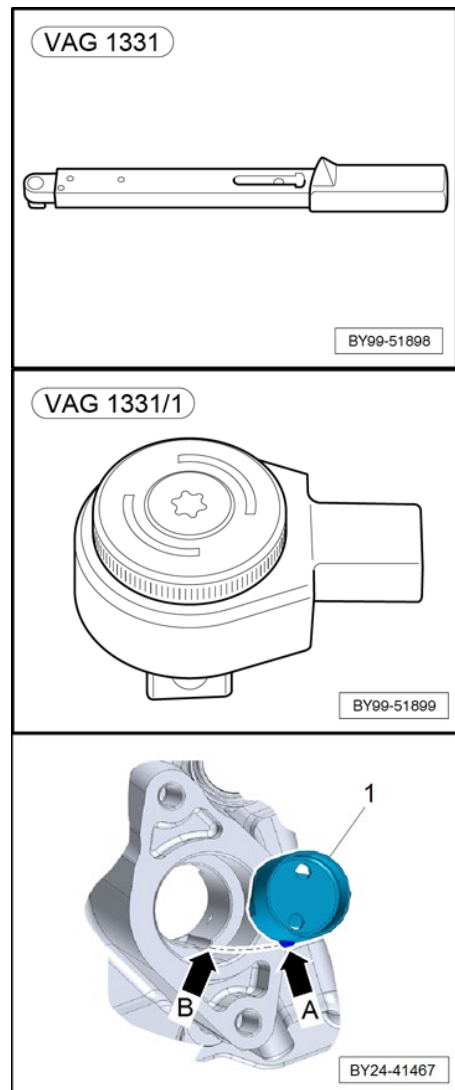

- Fit the high pressure pump into the camshaft cover making sure that a NEW O-ring is fitted.

 **Caution**

When installing the fixings -3- for the high pressure pump, first fit them by hand.

When first installed, the high pressure pump will protrude from the camshaft cover, therefore the following tightening procedure MUST be adhered to.

- ◆ Stage 1 — Sequentially hand tighten the fixings -3- two turns at a time until the pump contacts the mating face to prevent damage to the internal spring in the high pressure pump.
- ◆ Stage 2 — Torque tighten to 12 Nm.
- ALWAYS lubricate the fuel pipe threads with Microgleit DF977S lubricant prior to fitting.
- Torque tighten all remaining fixings.
-
- → Rep.-Gr.00
- Upon completion check for leaks.

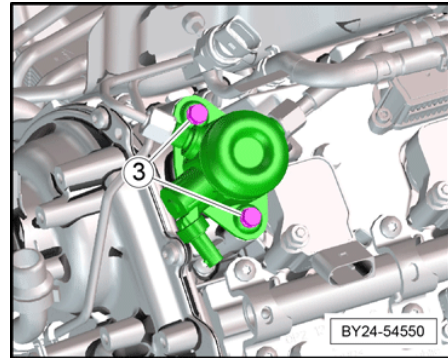

12. Install high-pressure fuel lines, banks 1 and 2:

Special tools and workshop equipment required

- ◆ Torque wrench -VAG 1331 -

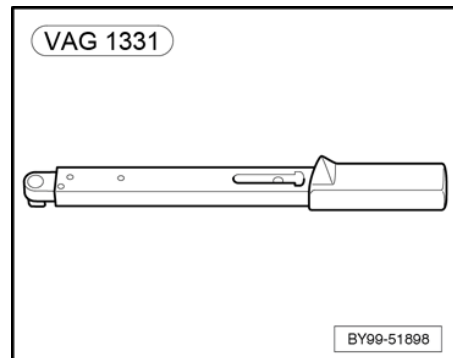

- ◆ Tool insert AF 17 -VAG 1331/6-

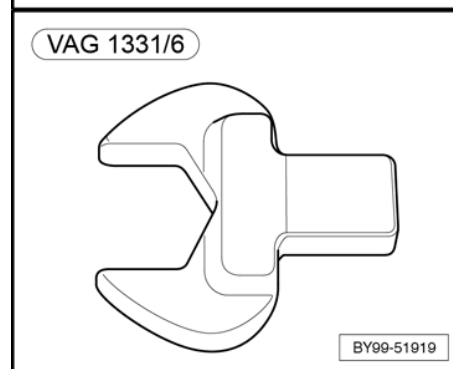

Consumables

Microgleit DF977S lubricant (refer to electronic parts catalogue "ETKA")

Installation

Installation is the reverse of removal procedure, noting the following.

- Bank 1

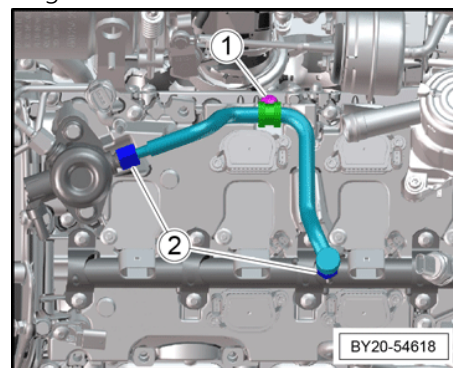

- Bank 2
- ALWAYS lubricate the union threads -2- with Microgleit DF977S lubricant prior to fitting.

The following procedure must be followed to ensure the high pressure fuel pipes are correctly tightened to eliminate the risk of fuel leaks.

Fit the fixing for the fuel pipe clamp first onto the cylinder head BEFORE tightening the high pressure fuel pipes. Do

- not tighten until the fuel pipes have been torque tightened.

 Note

Hand tighten the high pressure fuel pipe unions before torque tightening. Ensure the pipes are stress free before tightening.

Fit the fuel rail union first, then fit the high pressure fuel pump union.

Using the Torque wrench -VAG 1331 - and Tool insert AF

- 17 -VAG 1331/6- torque the high pressure fuel pipes -2- to the following torque.
- ◆ Stage 1 — Hand tighten.
- ◆ Stage 2 — 8 Nm.
- ◆ Stage 3 — + 50°.

 **Caution**

During the torque tightening procedure, ensure the fuel pipe remains central inside the union. Failure to do so may cause damage to the brass fitment seal and cause a fuel leak.

- Refit all previously removed components.
- Torque tighten all remaining fixings.

→ Rep.-Gr.00

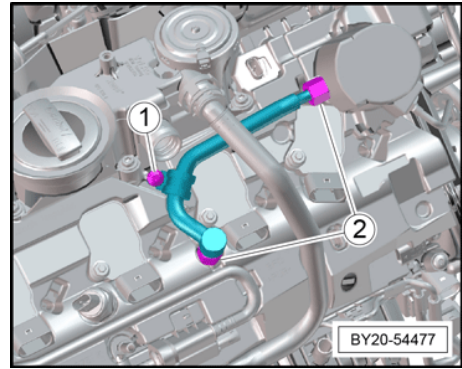

13. Install ignition coils:

Consumables

Silicone paste -G052565A1- (refer to ETKA)

Installation

Installation is the reverse of removal procedure, noting the following.

- Apply Silicone paste -G052565A1- to the area shown - arrow- prior to refitting the ignition coils.
- Push the ignition coils fully home to the abutment with the camshaft cover face.
- Ensure the correct electrical connector is fitted to each ignition coil.

Torque tighten all remaining fixings.

-

→ Rep.-Gr.00

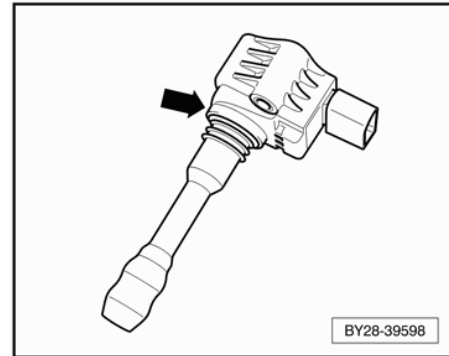

14. The following is applicable to both oil mist separators.

Installation

Installation is the reverse of removal procedure, noting the following.

- RENEW the seal.
- Refit all previously removed components.

Torque tighten all remaining fixings.

–

→ Rep.-Gr.00

15. Install upper chain housing covers:

Installation



Note

Fitting and sealing components using liquid sealant.

- ◆ Clean sealing faces to remove all traces of residual sealant.
- ◆ Sealing faces must be free of grease and oil.
- ◆ Clean sealing faces with primer Loctite -7515-.
- ◆ Use liquid sealant Loctite -5970-BM-.
- Apply liquid sealant Loctite -5970-BM- -arrow- on the chain housing cover.
- Install the chain housing cover within 5 minutes of applying the liquid sealant.

- Install chain housing cover -1-.
- Fit chain housing cover -1- on cylinder head.
- Fit and tighten screws -2- (9 Nm) uniformly.

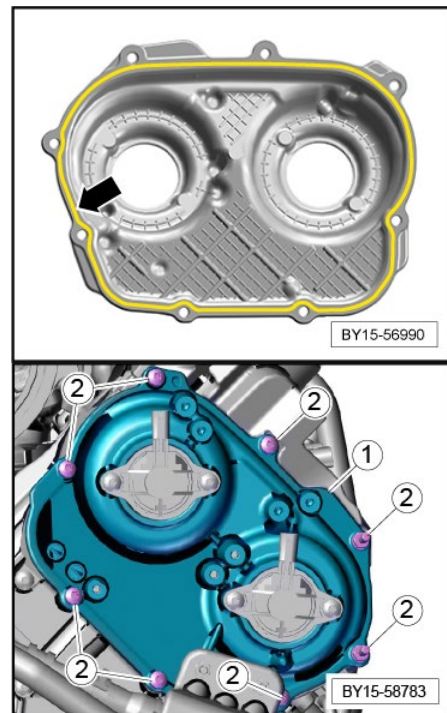

16. Install rear high-pressure fuel line:

Special tools and workshop equipment required

- ◆ Torque wrench -VAG 1331 -
- ◆ Tool insert AF 17 -VAG 1331/6-

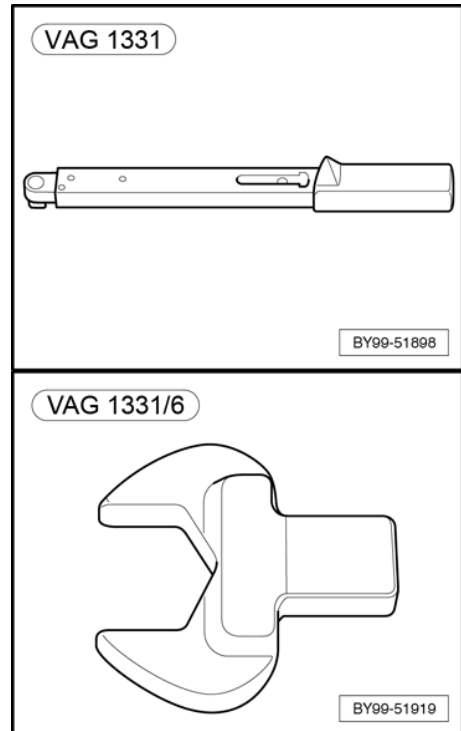

Consumables

Microgleit DF977S lubricant (refer to electronic parts catalogue "ETKA")

Installation

Installation is the reverse of removal procedure, noting the following.

- On both sides, lubricate the union threads -4- with Microgleit DF977S lubricant prior to fitting the link pipe.

Note

Hand tighten the high pressure fuel pipe unions before torque tightening. Ensure the pipes are stress free before tightening.

- Using Torque wrench -VAG 1331 - and Tool insert AF 17 - VAG 1331/6-, torque tighten the union fittings -4- to 8 Nm + 50°.

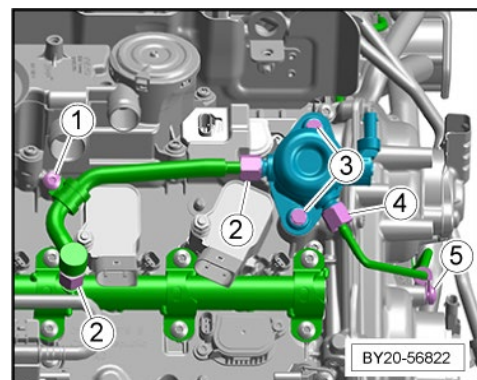

 **Caution**

During the torque tightening procedure, ensure the fuel pipe remains central inside the union. Failure to do so may cause damage to the brass fitment seal and cause a fuel leak.

- Fit NEW O-rings to the coolant pipes.
- Fit the catalyst support bracket -5- and secure with NEW fixings -4-, noting the information below:

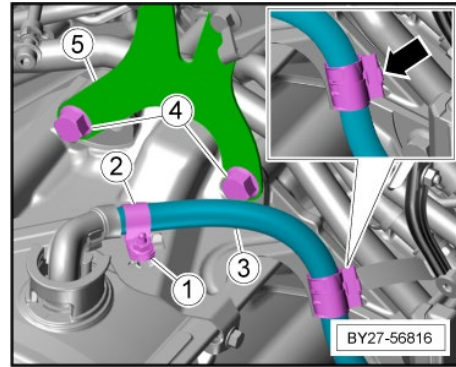

 **Note**

The fixings -1, 2 - for the catalyst support bracket (see previous graphic) are different lengths. Ensure the fixings are fitted in the correct location and torque tightened as shown below.

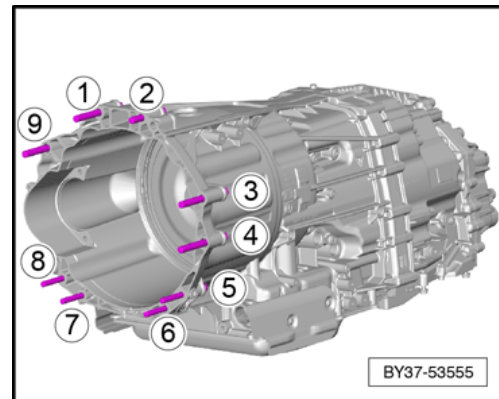

Table 1 - Automatic transmission retaining bolt chart

Position	Material	Size	Torque	Notes
1	Steel	M12 x 110	20 Nm + 60°	
2	Steel	M12 x 75	20 Nm + 60°	

-

Torque tighten all remaining fixings.

→ Rep.-Gr.00

17. Install catalytic converters, exhaust downpipes and heatshields:

Installation

Installation is the reverse of removal procedure, noting the following.

- Fit the lower heatshields.
- Fit a NEW sealing ring between the catalytic converter and the turbocharger.
- Fit a NEW V-band clamp -1- and fixing -arrow-.
- Fit a NEW sealing ring between the catalytic converter and exhaust downpipe.
- Secure the exhaust downpipe -1- with a NEW V-band clamp and fixing -arrow-.

Note

Position the downpipes together loosely back on to the catalytic converter to correctly align the exhaust components. Once the exhaust components are correctly aligned THEN a final torque tighten can be applied.

Torque tighten the fixings in the sequence shown to

- ensure stress free alignment of the catalytic converter -2-

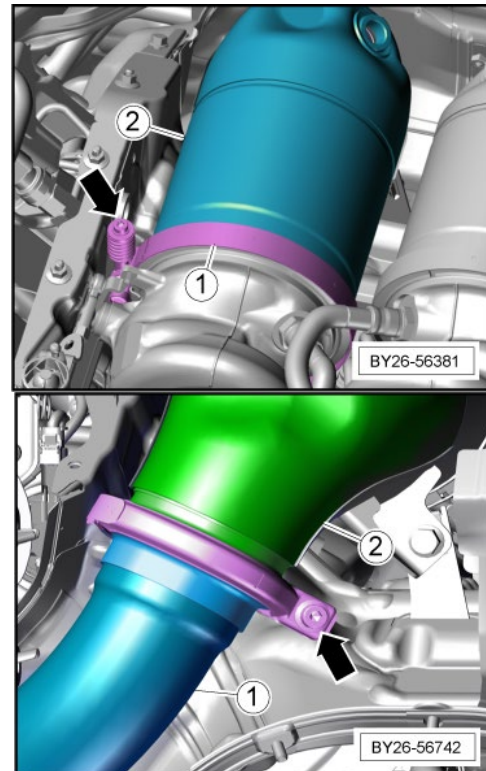

Stage	Fixing location	Torque figure
Stage 1	Catalytic converter to turbocharger "V-band" clamp	7 Nm
Stage 2	Catalytic converter to downpipe "V-band" clamp -arrow-	15 Nm

- Fit the upper heatshields.

Torque tighten all remaining fixings.

—

→ Rep.-Gr.00

18. Install engine:

Special tools and workshop equipment required

- ◆ Hydraulic lifting table -VAS 6131-

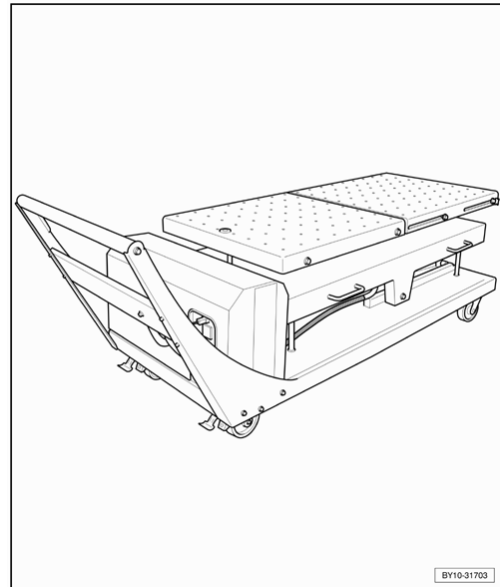

- ◆ Engine bung set -VAS 6122 or ASE40451200000-

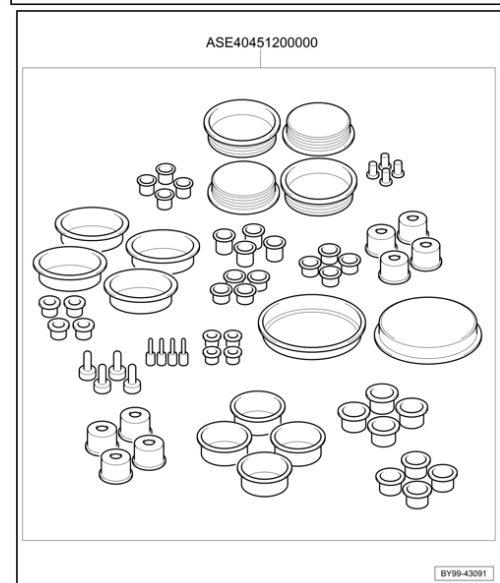

- ◆ Hose clip pliers -ASE45149200000-.

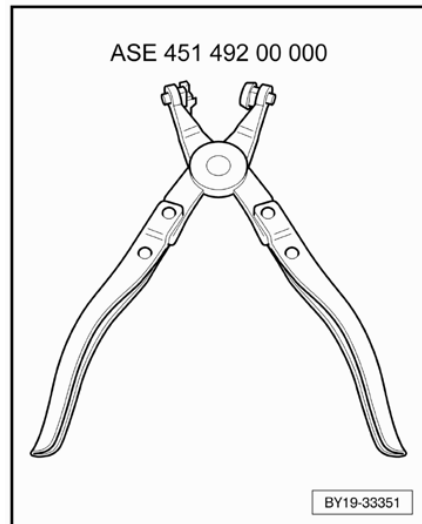

- ◆ Vehicle tester.

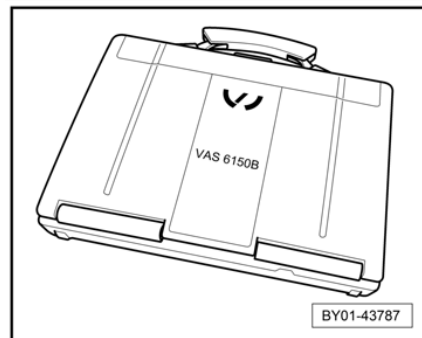

- ◆ Fuel connection cap (7.89 mm) (female) -WT 10259-.

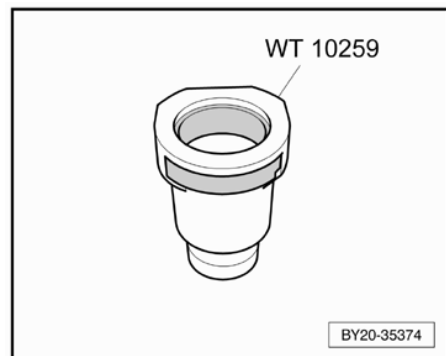

- ◆ Fuel connection cap (9.89 mm) (female) -WT 10260-.

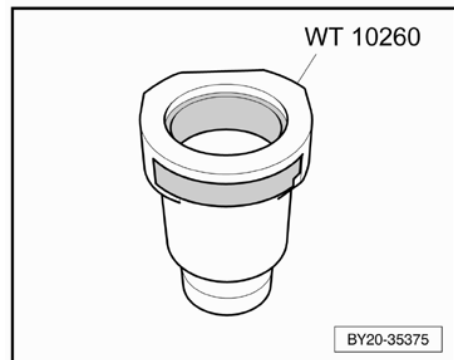

- ◆ Fuel connection cap (7.89 mm) (male) -WT 10250-

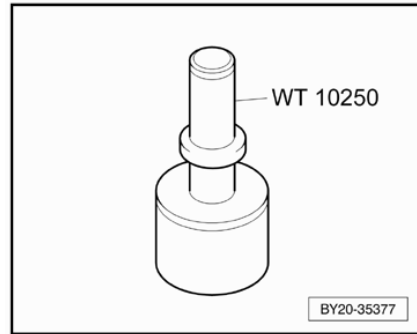

- ◆ Fuel connection cap (9.89 mm) (male) -WT 10251-

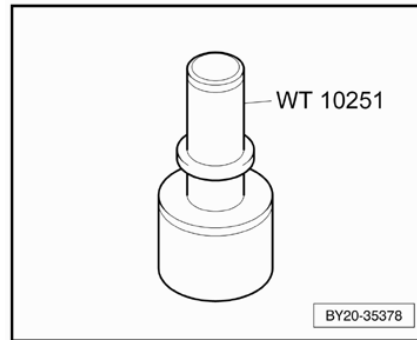

- ◆ Remote hose clip pliers -Such as VAS 6340- .

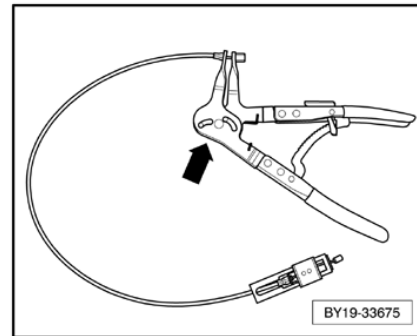

- ◆ Ball joint splitting tool -T40010A-

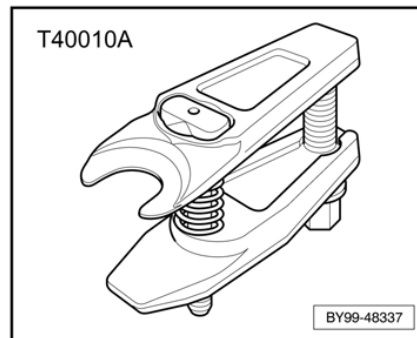

- ◆ Tensioning strap -T10038-

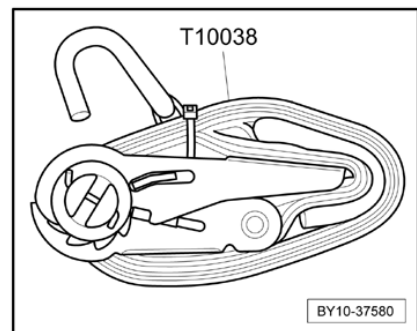

- ◆ Ball joint splitting tool -T10444-

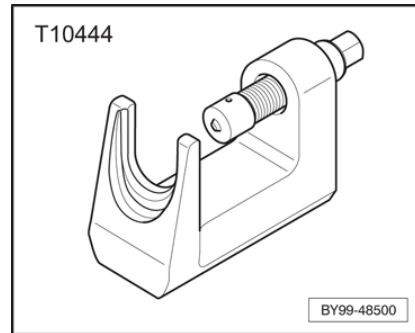

Installation

Installation is the reverse of removal procedure, noting the following.



Check all relevant components and engine components are clear whilst raising the engine and automatic transmission assembly into the vehicle engine bay.

- Align the front subframe with all previously marked lines - 1- prior to tightening the mounting fixings.



Insert all NEW fixings for the front subframe assembly and transmission assembly to secure them to the body before fully torque tightening the fixings.

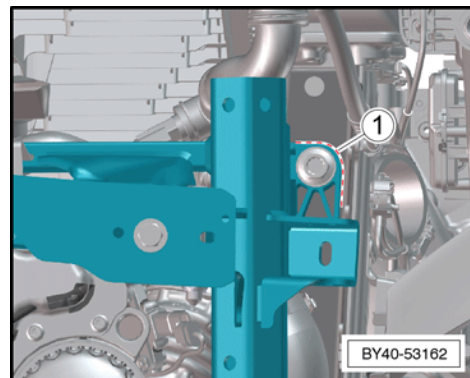

- Secure the front subframe with a NEW fixing -1- and fully torque tighten to (70) Nm +180°. Repeat on the other side.

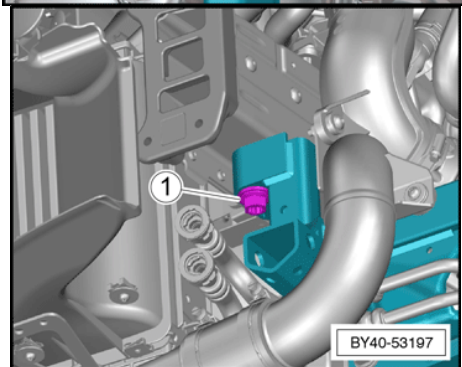

- Secure the front subframe with a NEW fixing -2- and fully torque tighten to (70) Nm +180°. Repeat on the other side.

Disregard all other positions.

Fit the shear plates, refer to "Front subframe shear plates - To remove and fit".

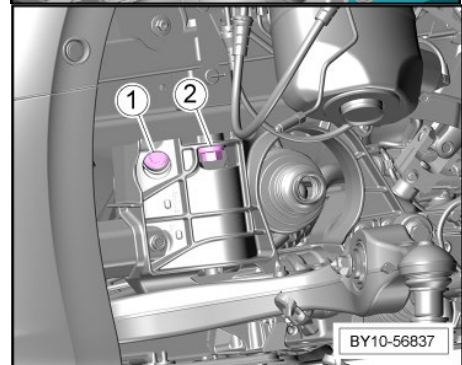

→ Rep.-Gr.40

- Secure the rear section of the front subframe with NEW fixings -3- and fully torque tighten to (70) Nm +180°.



Note

The rearmost fixing will have been installed with the refitting of the shear plates.

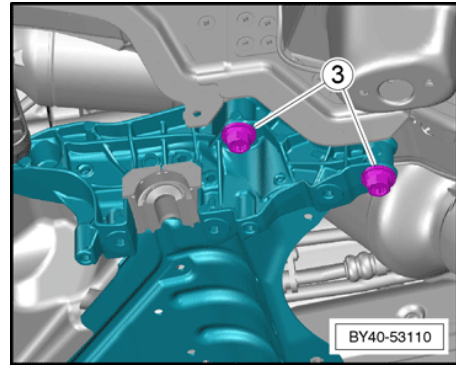

- Secure the transmission mounting to the body with NEW fixings -1- and fully torque tighten to (25) Nm + 90°.



WARNING

Ensure that ALL the subframe and transmission to body securing fixings are FULLY tightened to specification as described. Only then is it safe to remove the Hydraulic lifting table -VAS 6131-.

DO NOT remove the Hydraulic lifting table -VAS 6131- until it is safe to do so.

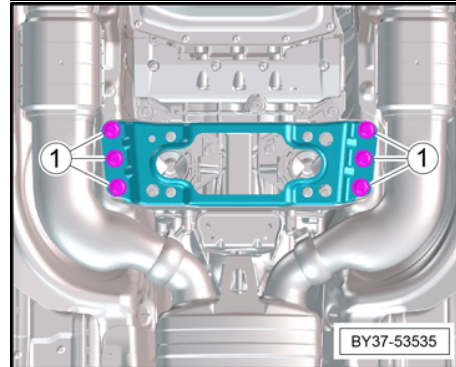

- ALWAYS fit NEW O-rings when connecting the "ATF" lines -1-.

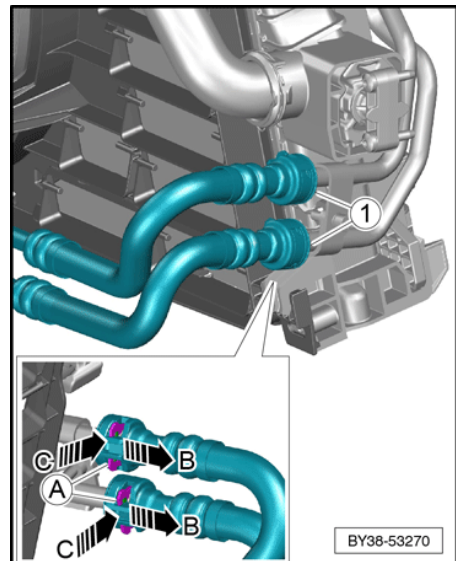

- Secure the air spring damper to the lower trailing arm -1- with NEW fixings -2- but DO NOT yet torque tighten. Repeat on the opposite side.

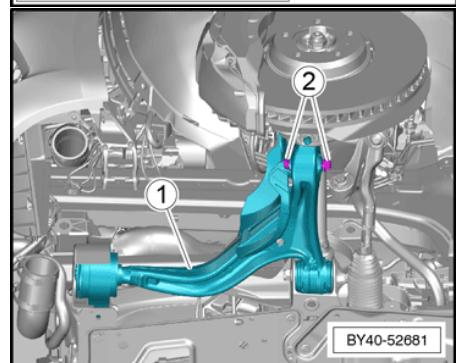

Fit the upper trailing arm -1- on the wheel bearing

- housing, secure with a NEW fixing -2- and torque tighten to 85 Nm. Repeat on the opposite side.

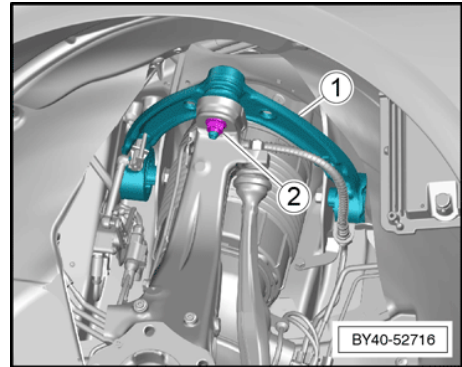

On both sides of the vehicle, raise the wheel bearing housing and torque tighten the fixings -2- to the specified value. Refer to "Raising the wheel bearing housing - To tighten bolts".

-

→ Rep.-Gr.40

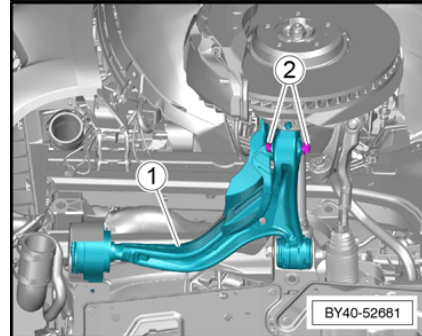

Only after torque tightening the lower lever fixings [-2 above-] can the track rod end -1- be fitted. Secure the track rod -1- with a NEW fixing -2- and torque tighten to (85) Nm.

-

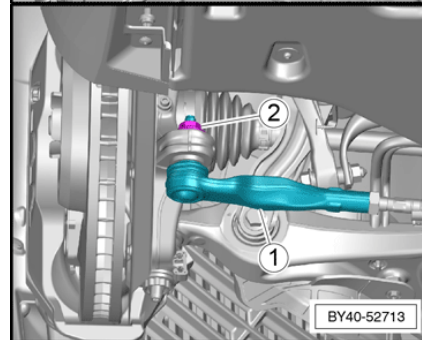

On both sides of the vehicle, secure the caliper with NEW

- fixings -1- and -2- and torque tighten both to 30 Nm, then plus a further 90°.

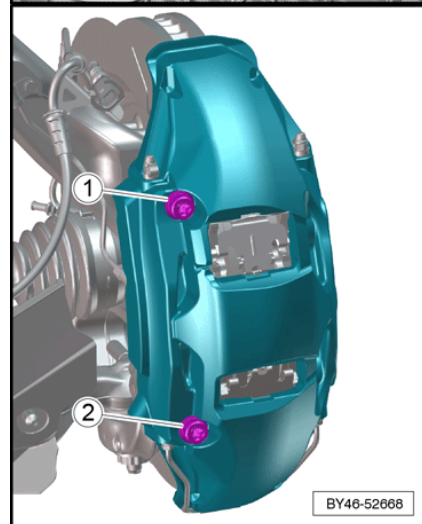

- On both sides of the vehicle install the fixings -2- (8 Nm) to secure the brake line -1- to the wheel bearing housing .

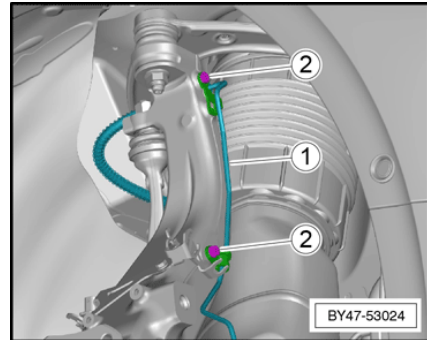

- Secure the steering rack universal joint -1- with a NEW fixing and torque tighten to (20) Nm +90°.

Disregard the direction arrow.

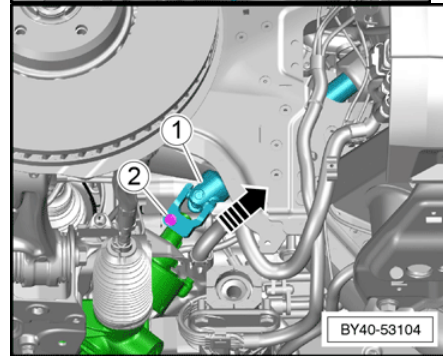

- Ensure the anti-roll bar wiring and steering rack harness is positioned correctly between the subframe -1- and the rear support -2-.

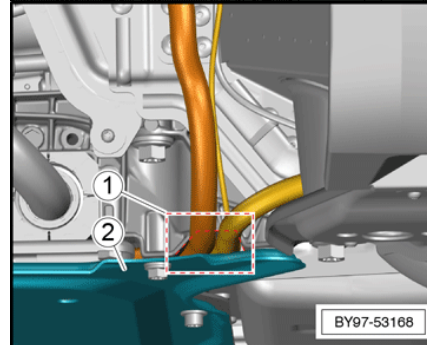

- Before refitting the under body earth strap, ensure the earth connection and bodywork is free of dirt and corrosion.

- Torque tighten the fixing (20 Nm) "Counter hold stud" -2- for the earth connection.

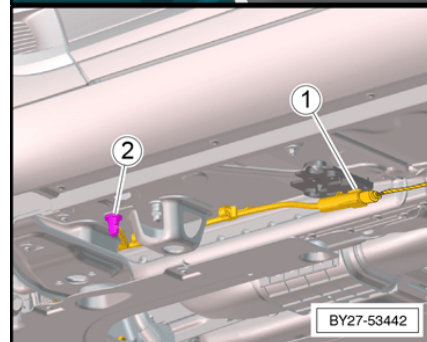

- Re-connect the four engine harness connections in the order of -D, C, B & A- on the engine control module -1-.

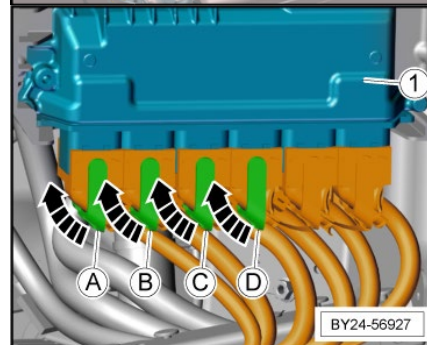

Apply a light film of spline grease (available in "ETKA") to

- the final drive splines -arrows- before refitting the propshaft.

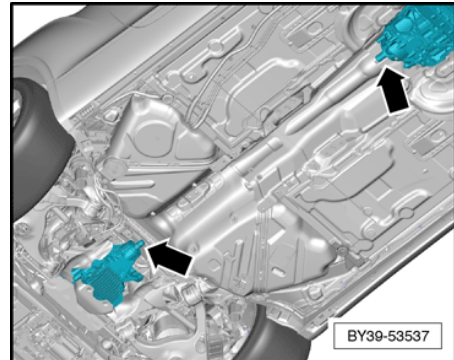

On the LH side of the engine, REPLACE the O-ring and

- install the refrigerant pipe into the compressor, then secure with the fixing -arrow- (25 Nm).

Refit the engine strut brace. Refer to "Engine cross brace - To remove and fit".

-

→ Rep.-Gr.50

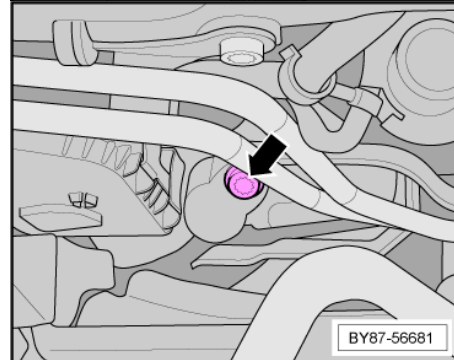

Install the NEW fixing -2- (50) Nm + 90° for the top

- engine mount bracket -3-.

Disregard all other positions.

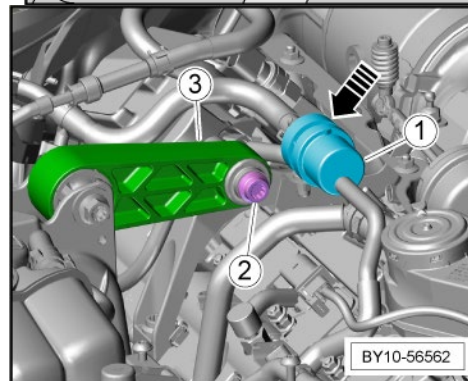

Before refitting the engine bay earth strap, ensure the

- earth connection and bodywork is free of dirt and corrosion.

Torque tighten the fixing -1- (20 Nm) for the engine earth strap.

-

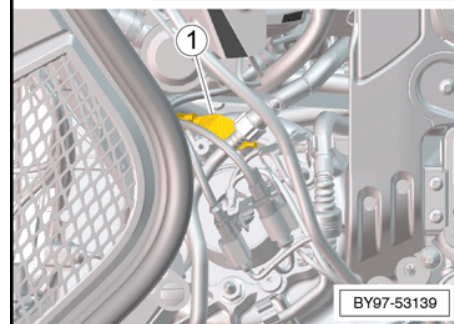
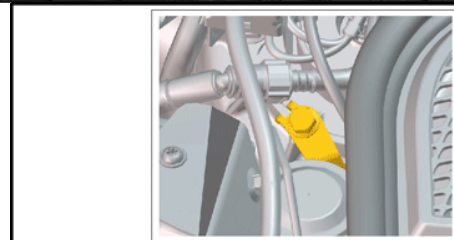

– Fit NEW O-rings before torque tightening the fixings -1- to 20 Nm.

Vacuum fill the cooling system. Refer to "Draining and filling coolant"

– → Rep.-Gr.19

Charge the air conditioning system. Refer to "Refrigeration system - To discharge and charge"

– → Rep.-Gr.87

Connect the battery. Refer to "Battery - To disconnect and connect"

– → Rep.-Gr.27

Clear any diagnostic faults with the Vehicle tester.

– → Rep.-Gr.97

Reset the vehicle geometry. Refer to " Vehicle geometry - Wheel alignment and ride heights"

– → Rep.-Gr.44

Briefly run the engine and check for leakage of any fluids or exhaust gases.

 **WARNING**

Use vehicle exhaust extraction equipment to extract the gases from the workshop.

– Road test the vehicle, check for leaks and re check all fluid levels and top up as necessary.

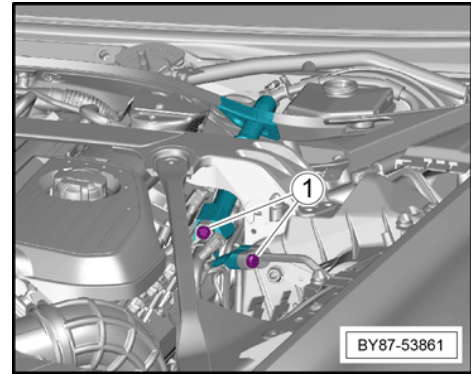

1. Remove engine:

Special tools and workshop equipment required

- ◆ Hydraulic lifting table -VAS 6131-

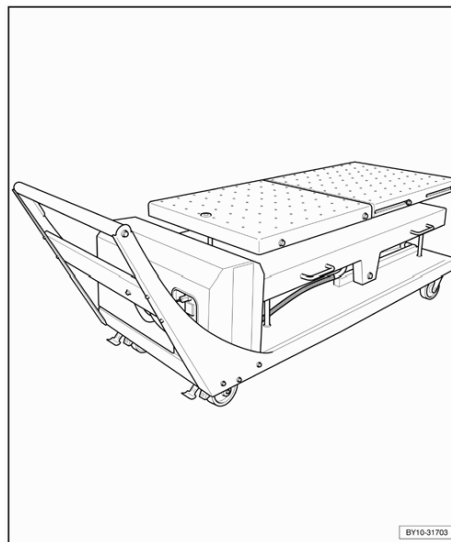

- ◆ Engine bung set -VAS 6122 or ASE40451200000-

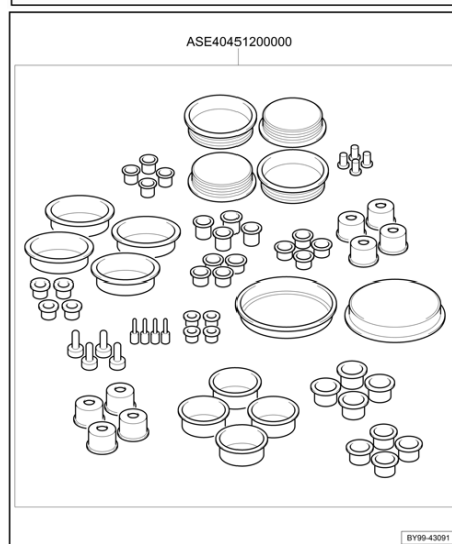

- ◆ Hose clip pliers -ASE45149200000-.

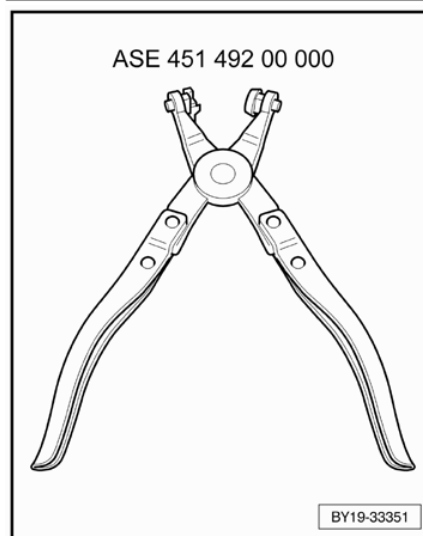

- ◆ Vehicle tester.

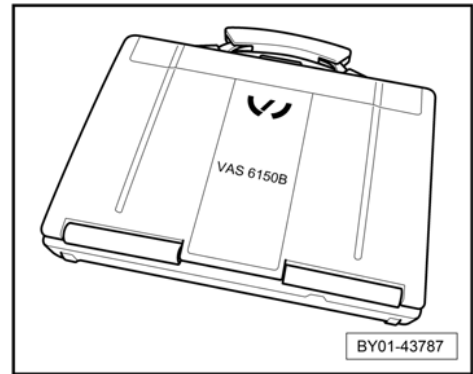

- ◆ Fuel connection cap (7.89 mm) (female) -WT 10259-.

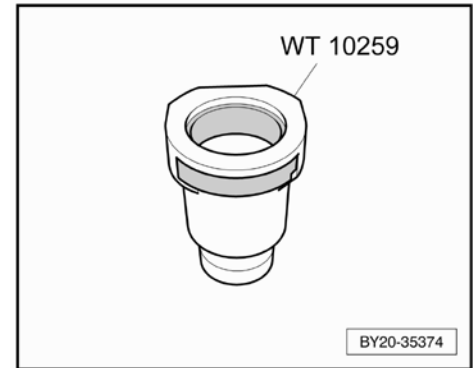

- ◆ Fuel connection cap (9.89 mm) (female) -WT 10260-.

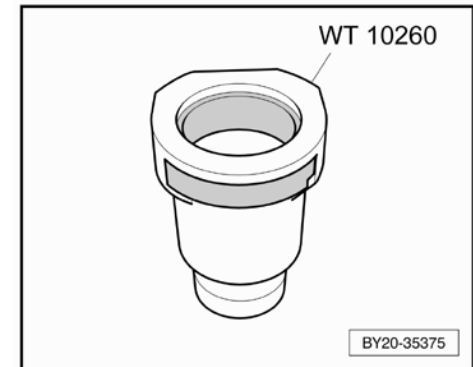

- ◆ Fuel connection cap (7.89 mm) (male) -WT 10250-.

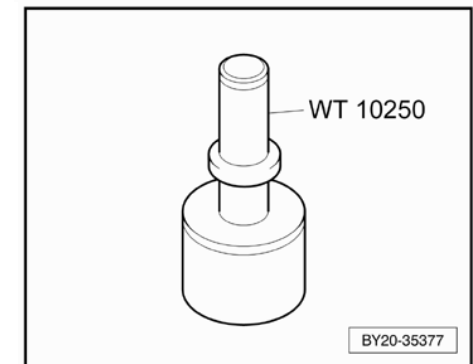

- ◆ Fuel connection cap (9.89 mm) (male) -WT 10251-

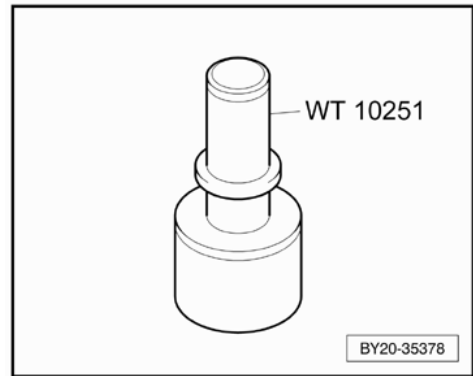

- ◆ Remote hose clip pliers -Such as VAS 6340- .

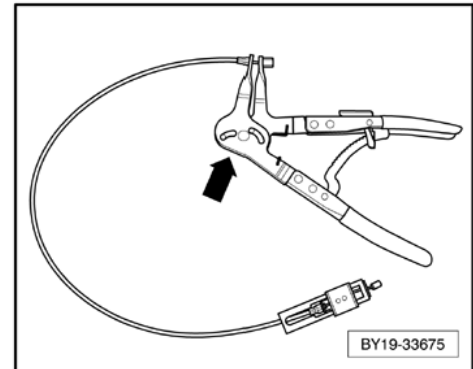

- ◆ Ball joint splitting tool -T40010A-

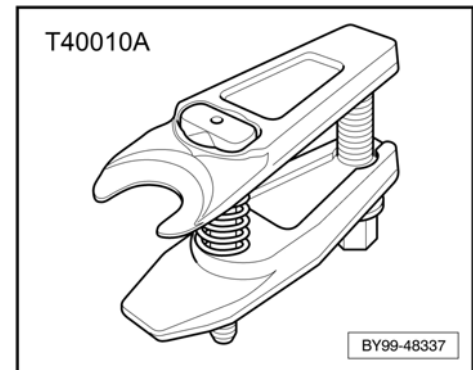

- ◆ Tensioning strap -T10038-

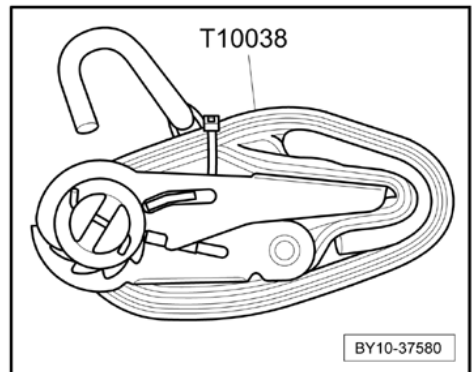

- ◆ Ball joint splitting tool -T10444-

Torque tightening values

Unless otherwise shown, standard torque values apply.

→ Rep.-Gr.00

Single use items

Within this procedure there are single use items which must be replaced and not reused. Ensure that new replacements are available prior to starting this procedure.

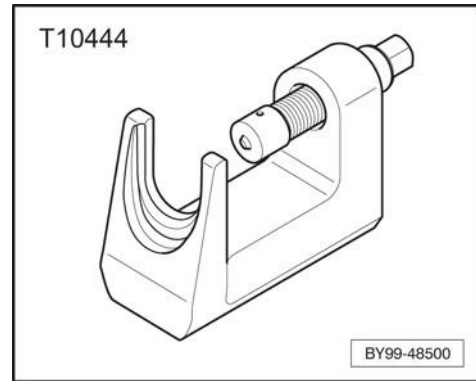

 **WARNING**

Fuel is highly flammable and extreme care must be exercised whenever the system is opened (i.e. pipes or

- unions disconnected, fuel cap removed) or when the fuel system is drained. The following basic rules should apply:-

- Always ensure adequate ventilation.
- Disconnect the battery.
- Ensure that adequate firefighting equipment is available in the vicinity of the vehicle.

Fuel system - Safety precautions.

- → Rep.-Gr.20

Fuel system - Rules for cleanliness.

- → Rep.-Gr.20

Before commencing work on and around the engine, ensure that it has cooled sufficiently, failure to do so may cause injury to personnel.

Avoid prolonged and repeated contact with oils and fluids etc.

- ◆ Always protect the skin with impervious gloves.
- ◆ Always wear suitable eye protection.

 **Caution**

Suitably blank or bung all disconnected electrical connectors, electrical connections, hoses and pipe work to prevent the ingress of dirt and moisture.

Plastic connectors and fittings can become brittle with age. Do not use excessive force to remove hoses. Replace any damaged fittings as necessary.

During removal, the orientation of fuel hoses must be noted. The same hose orientation is required for fit, i.e. flow direction, location markers and spring clamp positions.

Do not over strain the connections.

 Note

The following procedures regarding fitting and servicing of "quick connects" must be observed:-

Disconnecting:- Using a cloth or soft brush, wipe the external surface of the connector and male tube to remove loose dirt and road salt. Twist the connector about the tube or flush the joint with a mild penetrating oil such as WD40 or CRC spray to remove any stubborn contaminants. Using an airline, blow out any accumulated dirt and road salt from the retainer area of the connector. Squeeze the side of the connector and simultaneously pull the hose from the pipe fitting. Do not allow dirt or any foreign matter to contaminate the lines or allow the lines to drag on the floor.

Connecting:- Using a clean cloth, wipe the tube end. Check the O-rings in the hose and the sealing surfaces on the pipe for damage. Apply a coating of clean engine oil over the entire male tube end surface, up to the bead. Push the "quick connector" fitting over the tube until the retainer seats, with an audible click. To ensure that a secure connection has been made and has locked in position, pull back on the "quick connector".

 Note

Dispose of any collected oils, fuel or fluids in accordance with local environmental regulations.

→ Rep.-Gr.20

 Note

Some images show W12 variant for illustration purposes only, however they are applicable to all variants unless otherwise stated.

Removal

- Fit vehicle protection.

Discharge the air conditioning system. Refer to

"Refrigeration system — to discharge and charge".

→ Rep.-Gr.87

Deactivate the 48v system where fitted. Refer to "48v system — to activate and deactivate".

→ Rep.-Gr.27

Place the vehicle on a ramp and set to "Jack" mode. Refer to "Raising and supporting the car".

→ Rep.-Gr.99

Disconnect the battery. Refer to "Battery — to disconnect and connect".

→ Rep.-Gr.27

Remove the front undersheet. Refer to "Front undersheet – To remove and fit".

→ Rep.-Gr.66

Remove the front and rear sections of the side undersheets on both sides, Refer to "Side undersheets – To remove and fit".

→ Rep.-Gr.66

Remove the front wheel arch liners. Refer to "Front wheel arch liners — to remove and fit".

→ Rep.-Gr.66

Remove the engine strut brace. Refer to "Engine cross brace - To remove and fit".

→ Rep.-Gr.50

- Detach the fuel line rubber mount -1- from the carrier bracket at the point shown -arrow-.
- Remove and DISCARD the fixing -2- (50) Nm + 90° and detach the top engine mount bracket -3-

i Note

The other fixing would have previously been removed with the engine strut brace.

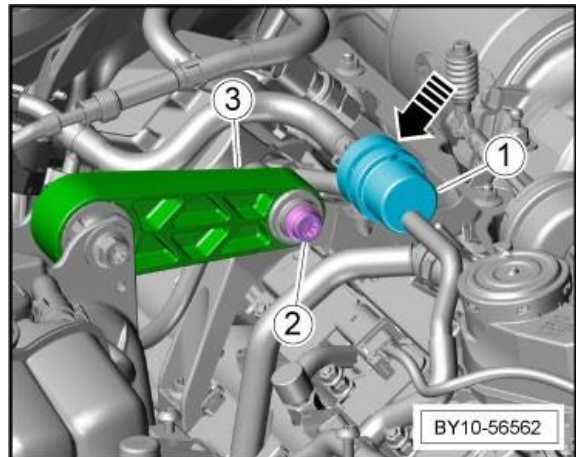

- On the RH side, disconnect the two electrical connections -1- and remove from the bracket -2-.
- Remove the two fixings -arrows- and detach the harness carrier bracket -2-.

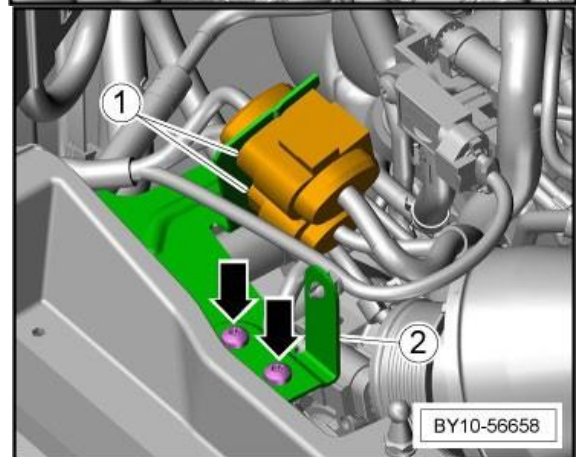

- On both sides of the vehicle release the hose clips -1- (5.5) Nm and remove the charge hoses -3- from the pressure pipes.

Disregard all other positions.

Remove the horns. Refer to "Twin horns - To remove and fit".

→ Rep.-Gr.96

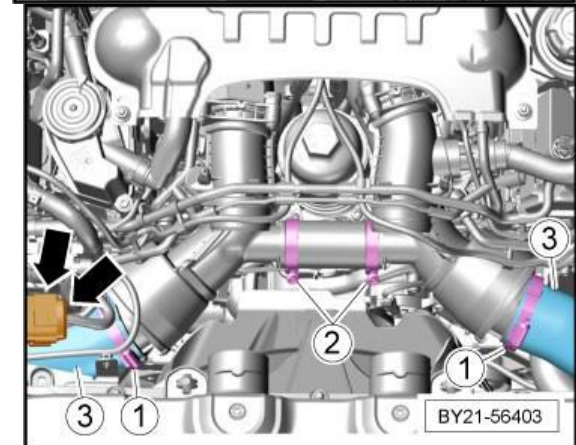

- On both sides, unclip the horn wiring harness from the front support -arrows- and move away from engine.

Remove the air intake hoses. Refer to "Air intake ducts - To remove and fit".

→ Rep.-Gr.21

- Remove the air intake duct from behind the radiator. Refer to "Radiator air guide - To remove and fit".

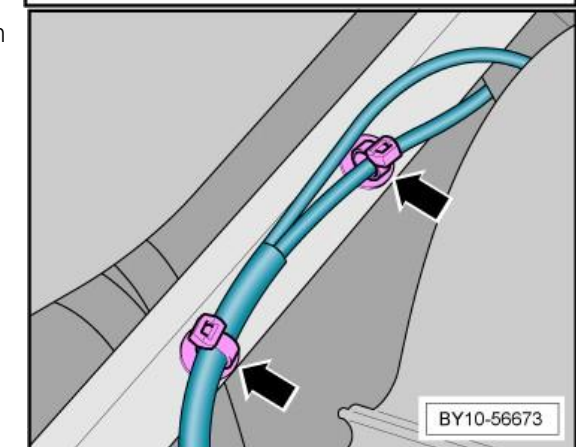

→ Rep.-Gr.19

Remove the engine cooling fan. Refer to "Cooling fan — To remove and fit".

→ Rep.-Gr.19

On both sides, disconnect the electrical connection -1- to the boost pressure sensor.

Disregard all other positions.

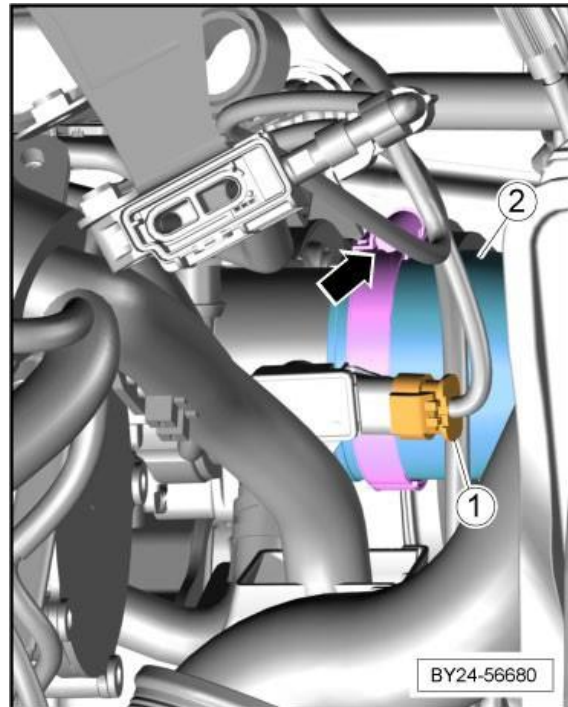

On the lower LH side, release the quick connect - arrow- and detach the bottom radiator hose connection and drain into a suitable container.

Once the coolant system has fully drained, refit the hose connection and secure with the clip -arrow-.

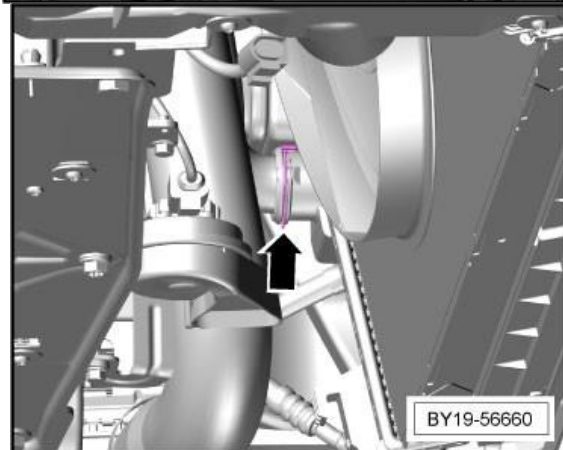

At floor level

- Using Hose clip pliers -ASE45149200000- , release the "Springband" clamps -arrows- and disconnect the two hoses from the coolant pump.

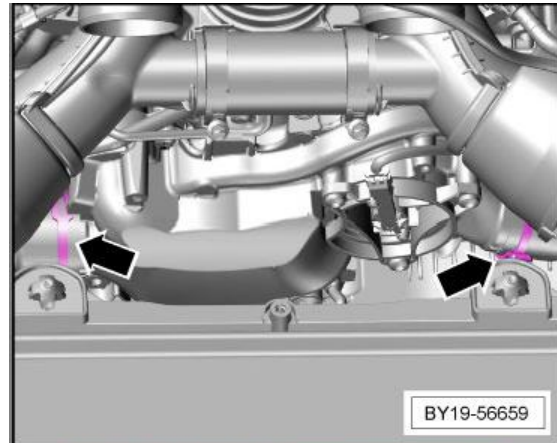

- In order, disconnect the four engine harness connections -A, B, C & D- from the engine control module -1-.

i Note

Suitably mark each harness connector to the relevant control unit to aid installation.

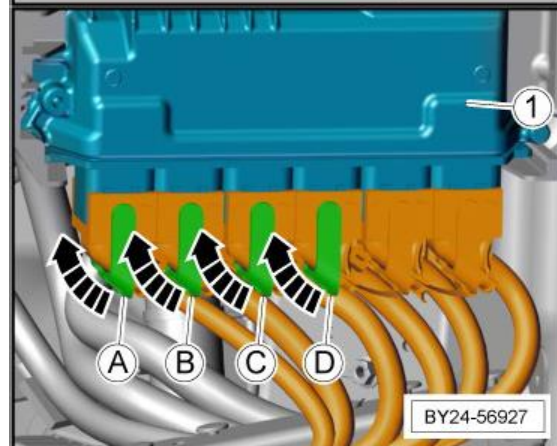

- Release the harness at the clipping point -A-.
- Remove the fixing -B- (9 Nm) to allow the harnesses -1- to be manoeuvred through the inner wing aperture.

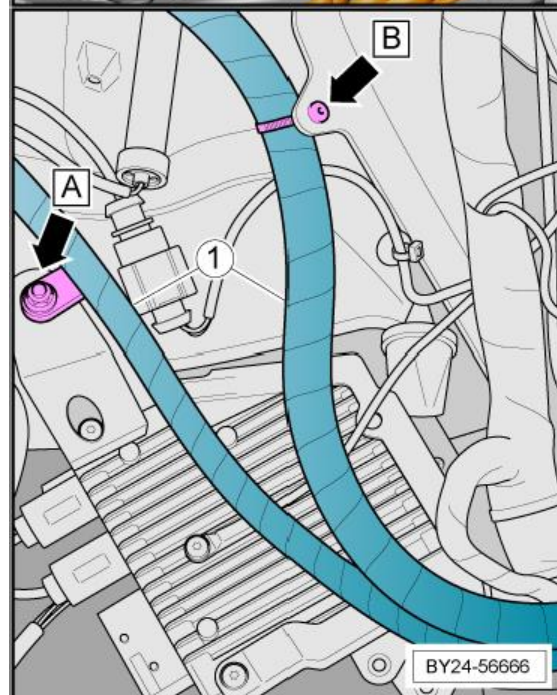

- On the LH side of the engine bay, remove the two
- fixings -1- (20 Nm), disconnect the "HVAC" pipes and DISCARD the O-rings.

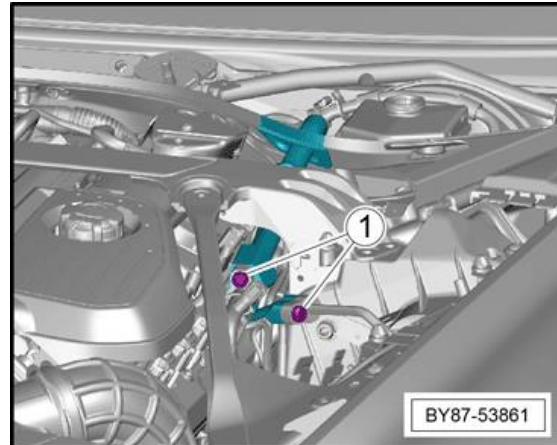

- On the LH side of the engine bay, disconnect the
- vacuum line "quick connect" -1- to the brake booster.
 - Release the harness edge clip -2- from the bracket.
 - Unclip the wiring harnesses from their clipping points -3-.
 - Release the harness clipping points -4- and fold the harness over the top of the engine so that it is clear of the vehicle body.

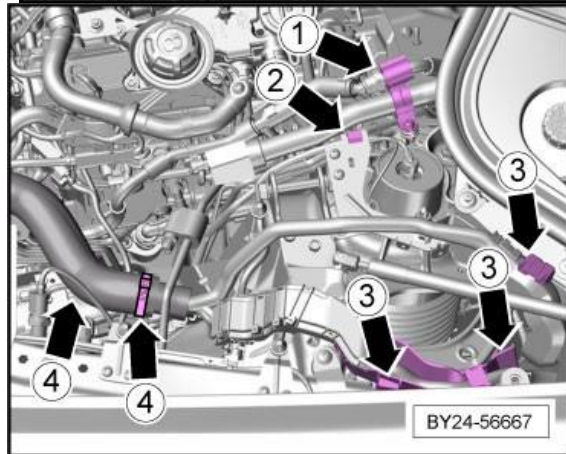

- On the LH side of the engine bay, disconnect the
- vacuum line "quick connect" -arrow- to the vacuum reservoir.

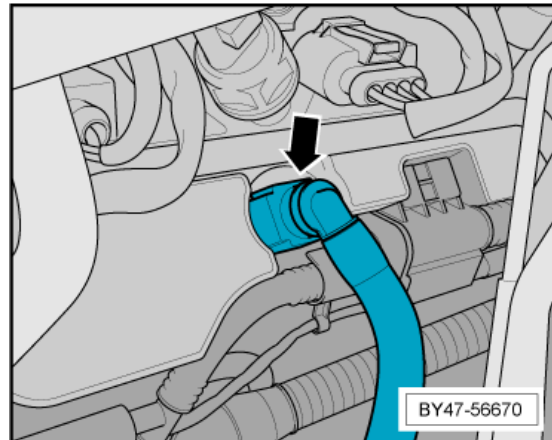

- On the RH side of the engine bay and using Hose clip pliers -ASE45149200000-, release the
- "Springband" clamp -1- and disconnect the vacuum hose -2- to the expansion tank valve line.
- Disregard all other positions.

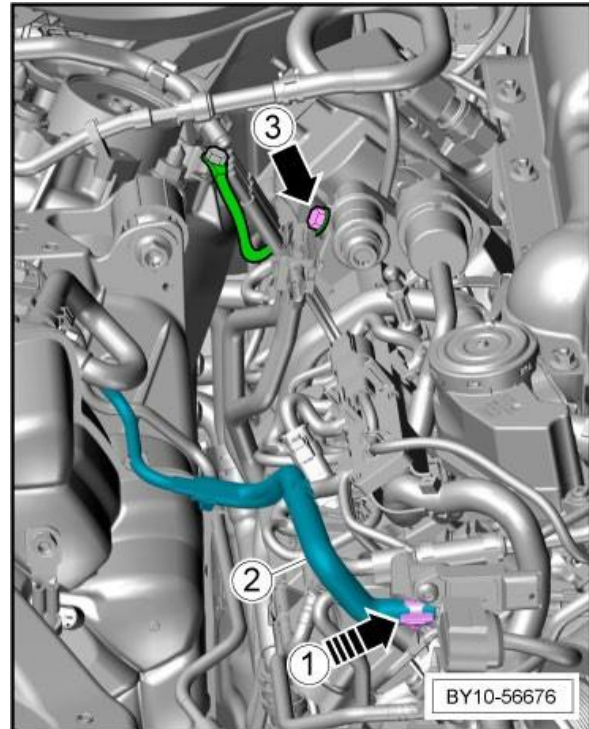

- Disconnect the engine bay earth strap -1- (20 Nm).

Image for illustration purposes only.

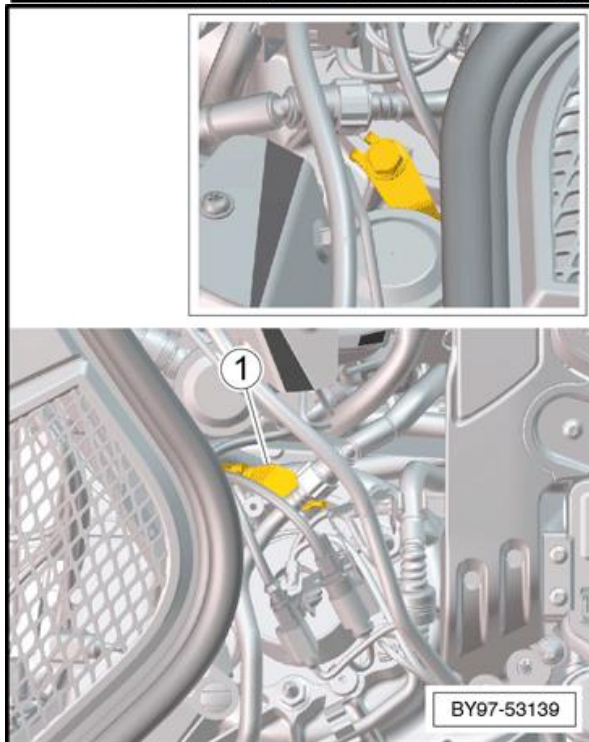

- On the RH side of the engine bay, press the
- latch in -1- on the engine bay charging post and release the cover -2-.

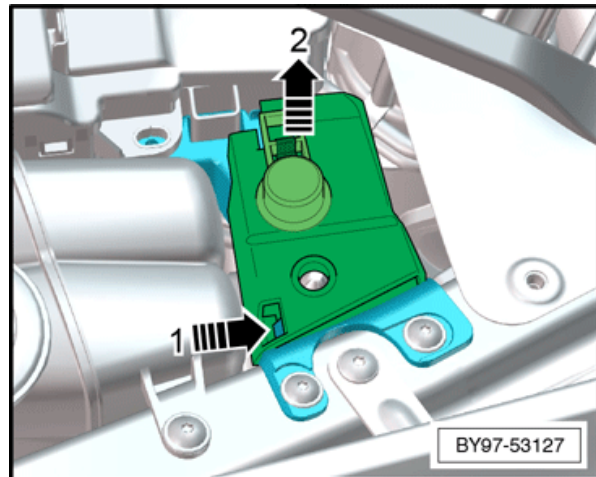

- Remove the fixing -2- (20 Nm) and detach the starter cable.



Note

Disregard items -1 & 3-.

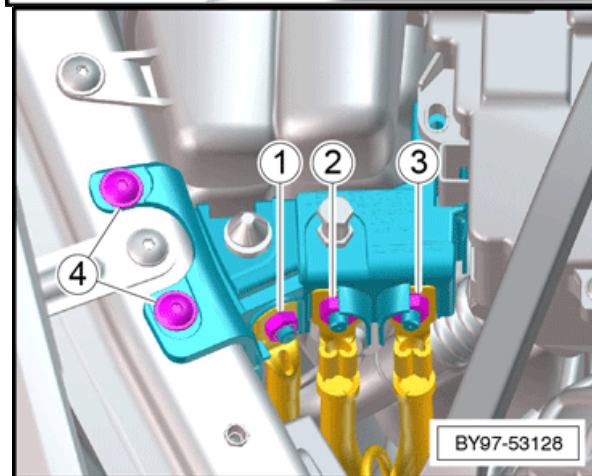

- Unclip the starter cable from the chassis -1-.

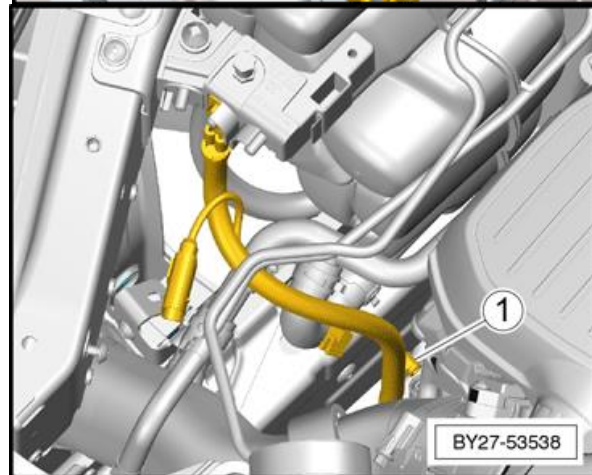

On the RH side of the engine bay, disconnect

- the fuel feed line "quick connect" -1- and detach the fuel line -2-.

Using Hose clip pliers -ASE45149200000- ,

- release the "Springband" clamp -3- and disconnect the vent line -4-.

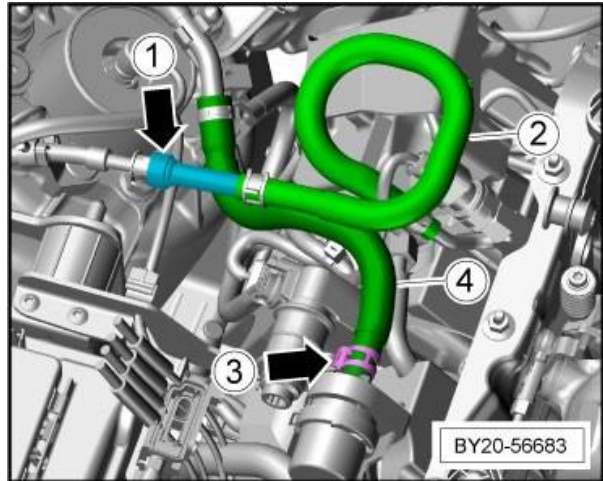

On the LH side of the engine, remove the

- fixing -arrow- (25 Nm), detach the refrigerant line from the compressor and DISCARD the O-ring.

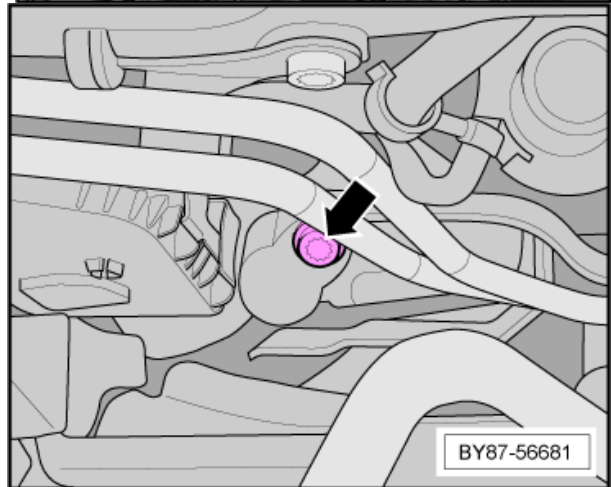

On both sides (where "OPF" [Otto Particulate Filter] is fitted), disconnect the electrical

- connection -1- from the exhaust pressure sensor and detach at the clipping point -arrow-.

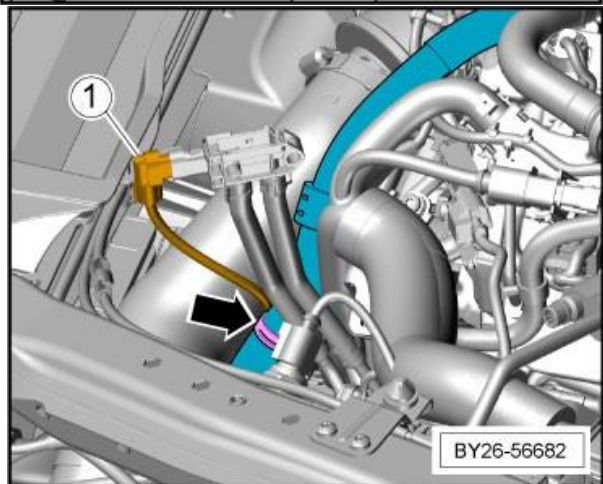

[Vehicle raised]

– On the LH side of the vehicle where "EAWS" is fitted:

- ◆ Remove the fixing -2- (5.5 Nm) securing the earth connection to the EAWS control module.
- ◆ Release the harness retainer -3- securing the harness -1- to the body.

- ◆ Disconnect the harness connections -2- and -5- only.



Note

The remaining connections -1, 3 and 4- can be left connected to the module.

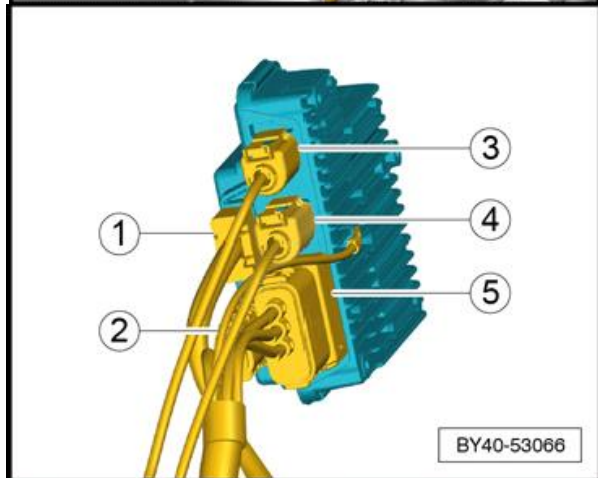
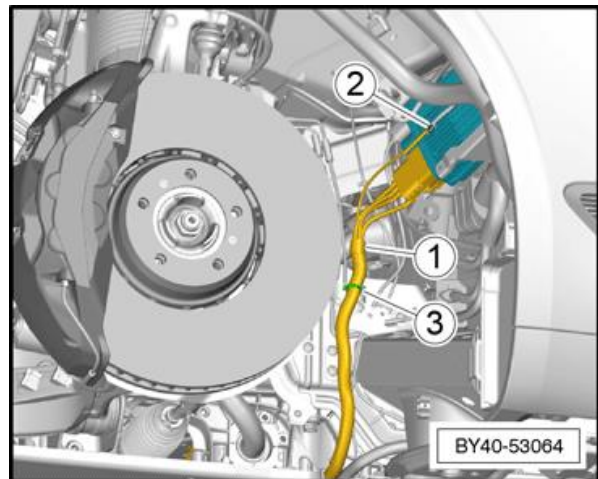

[Continuation]

– Under the LH side of the chassis, disconnect the power steering power feed -1- and remove the fixing -2- (20 Nm) for the earth connection.



Caution

Counter holding the earth stud -2- is strongly advised when loosening and tightening.

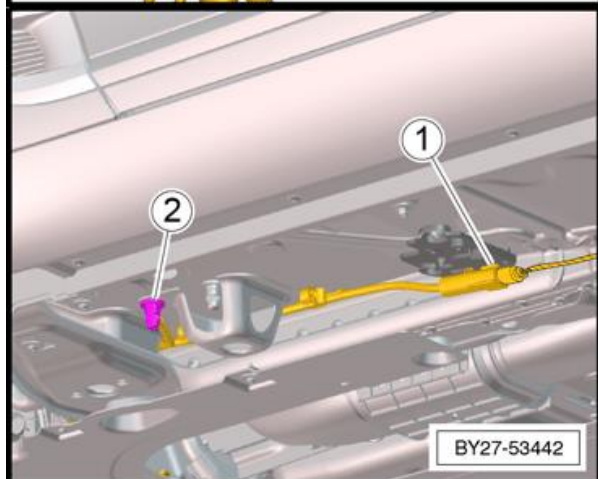

Front subframe front brace

- Remove fixings -1- (55 Nm).
- Remove fixings -2- (30 Nm).
- Remove fixing -3- (6 Nm).
- Remove fixings -4- (23 Nm).
- Remove the front subframe front brace.

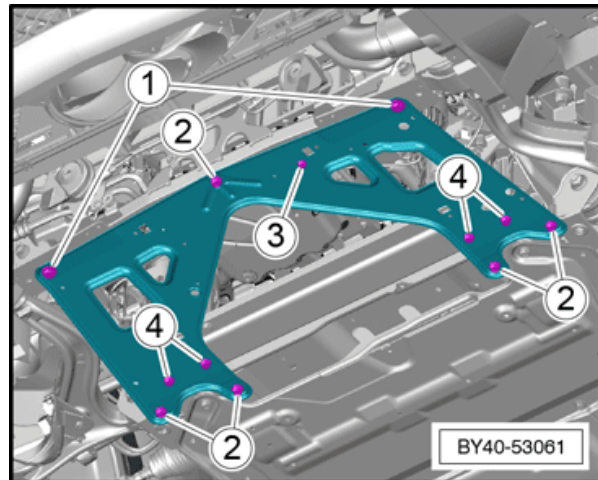

Front subframe rear brace

- Remove fixings -1- (30 Nm).
- Remove fixings -2- (30 Nm).
- Remove the front subframe rear brace.

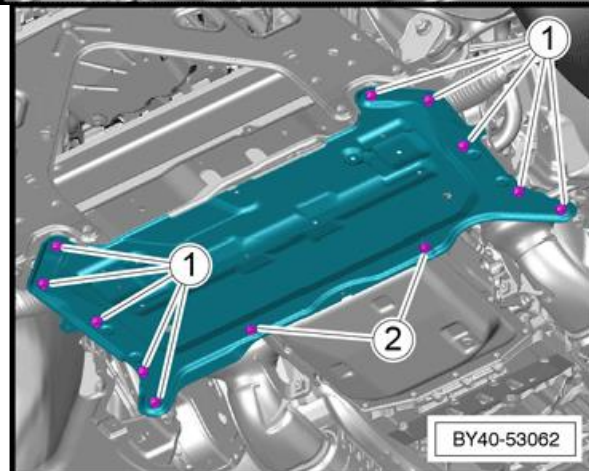

- Remove and DISCARD the fixing (85 Nm) -2- and remove track rod end -1- from the wheel bearing housing using Ball joint splitting tool - T40010A- .

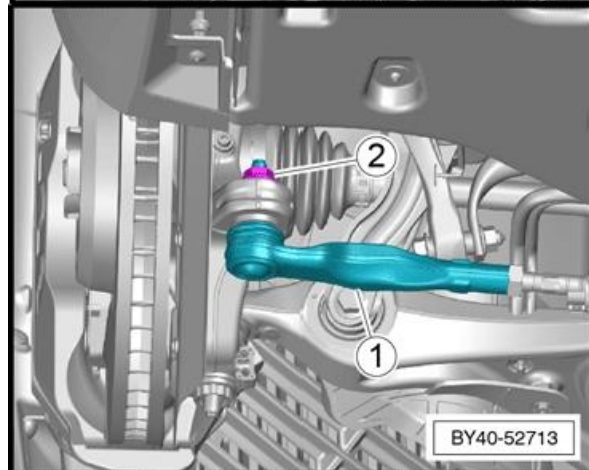

Remove and DISCARD the bolt -2- (20 Nm +90°) for the steering rack universal joint -1-. Push the steering column universal joint backwards - arrow- off the steering rack pinion.

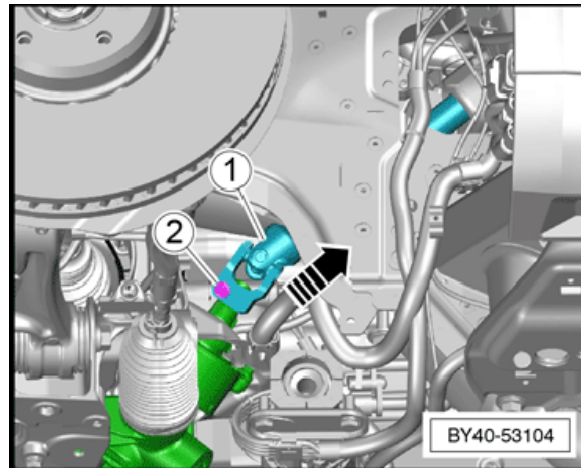

On both sides, disconnect the electrical connection -arrow- from the exhaust temperature sensor.

Detach the harness edge clip -1- from the subframe.

Detach the carrier -2- from the rear section of the subframe.

Separate the carrier -2- from the top cover -3- and release the harness connection.

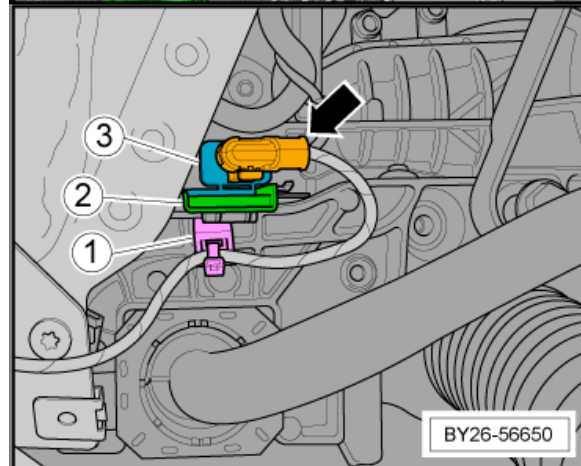

i Note

RH shown, LH symmetrically opposite.

Disconnect the harness interconnect -1- and unclip from the subframe -2- (located in the right hand wheel arch).

Remove the shear plates, refer to "Front subframe shear plates - To remove and fit".

→ Rep.-Gr.40

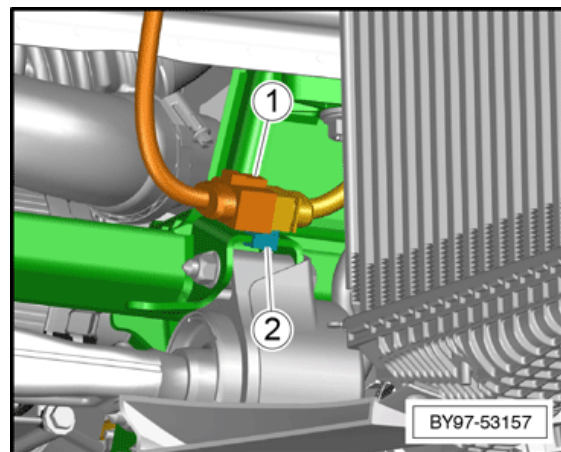

- Using Remote hose clip pliers -Such as VAS 6340-,
- release the "Springband" clamps -arrows- and detach the coolant hoses -1- and -2-.

i Note

There will be some residual coolant in these hoses, use a suitable container to catch the residual and bung up the hoses to prevent further drips.

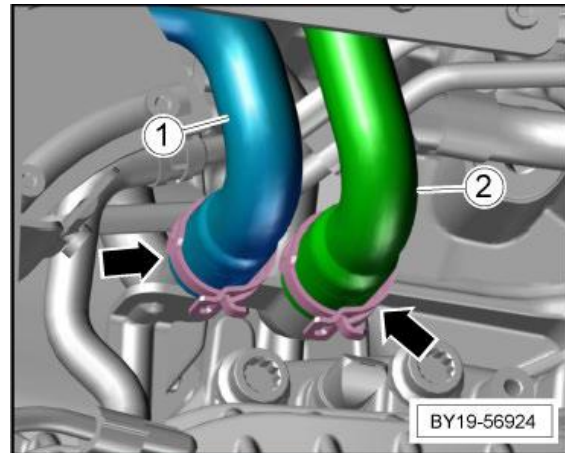

- On both sides, disconnect the harness connection
- for the brake pad wear indicator -1- from the holder -2- -arrow A- and disconnect it -arrow B-.

i Note

The pad wear indicator must be renewed if the retaining clip is lost or broken.

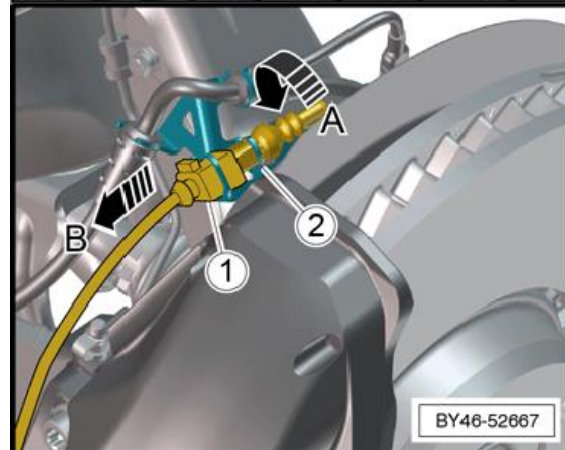

- On both sides of the vehicle remove the fixings -
- 2- (8 Nm) securing the brake line -1- to the wheel bearing housing.

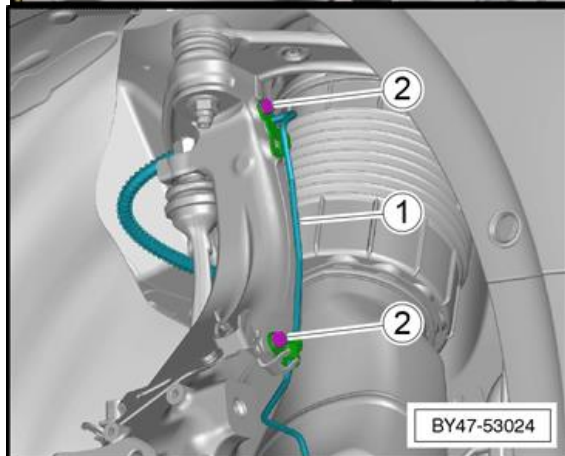

- On both sides, remove and DISCARD the fixings -
- 1- and -2- securing the caliper to wheel bearing housing and remove the caliper.
 - Using Tensioning strap -T10038-, suspend the caliper from the vehicle body.

 *Caution*

Do not allow the caliper to hang under its own weight as this could stress and damage the brake hose.

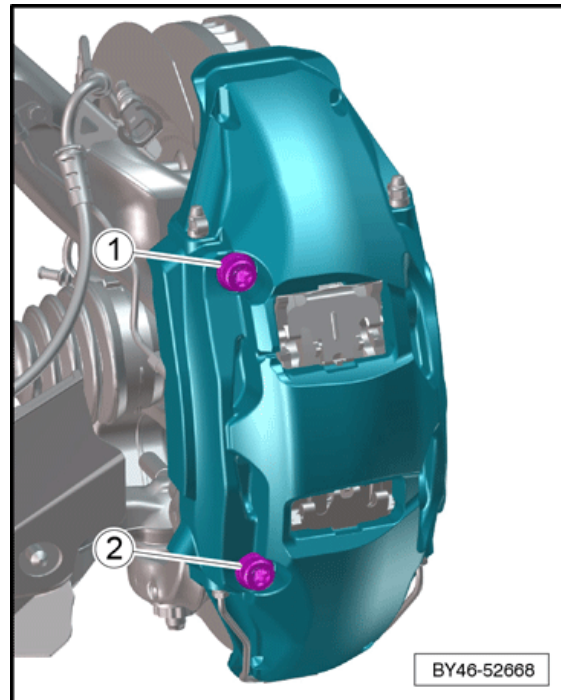

- On both sides, disconnect the harness connector - 2- for the wheel speed sensor.

 *Note*

Disregard items -1- and -3-

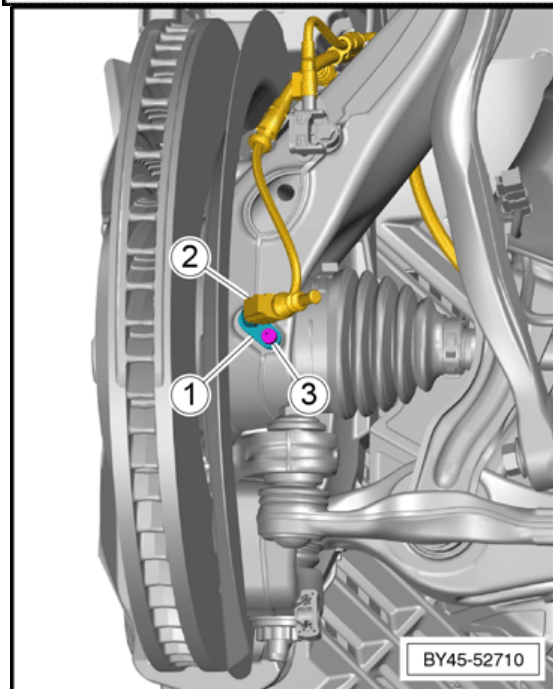

- On both sides, remove the fixings -arrows- and remove the brake disc from the vehicle.

Image for illustration purposes only.

 **WARNING**

- ◆ Brake discs are heavy. Remove carefully. Do not allow grease or fluids to come into contact with the brake pad linings and discs, as the braking efficiency of the vehicle will become severely affected.

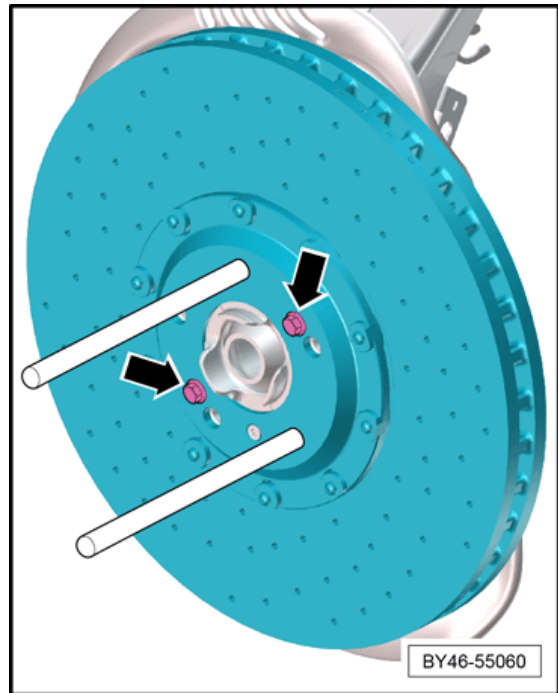

- On both sides, remove the fixings -2- and remove the sensor harness and bracket -1- from the wheel bearing housing.

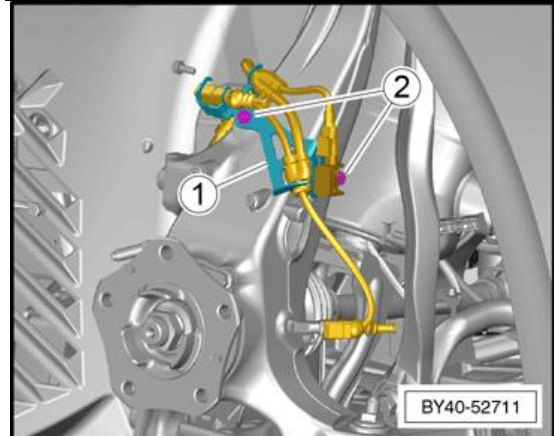

- On both sides, remove and DISCARD the fixing -2- on joint pin for upper trailing arm -1-.

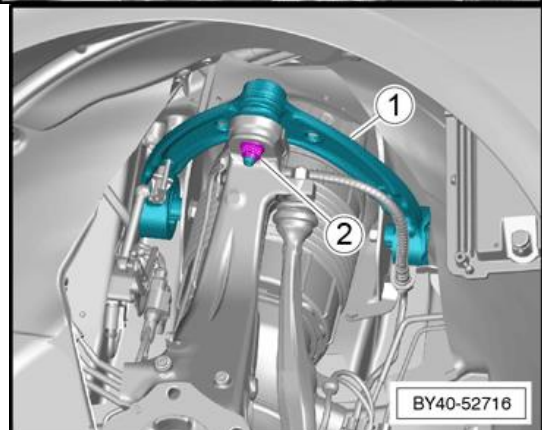

- On both sides, remove and DISCARD fixing -2- from lower trailing arm -1- and air spring damper.
- Remove the centre section of the exhaust system.
- Refer to "Exhaust centre section - to remove and fit".

→ Rep.-Gr.26

- Remove the propshaft. Refer to "Propshaft - To remove and fit".

→ Rep.-Gr.39

- On the front RH side, remove the automatic transmission pipes -1- from the bottom of the radiator assembly.

 Note

To detach the ATF lines release the "quick connect" unions -A- from the retaining latch -B-.

Push the "quick connect" outwards -C- and detach the pipe.

 Note

Please place a suitable container underneath the vehicle to catch any escaping fluid.

Dispose of any waste fluids according to local environmental regulations.

Suitably blank off any open connections to prevent ingress of dirt and moisture.

- On both sides of the vehicle, undo the worm drive clamp -1- (5.5 Nm), then disconnect the boost hose -3- off the intercoolers and suitably bung both the pipe and the intercooler.
- Disregard all other positions.

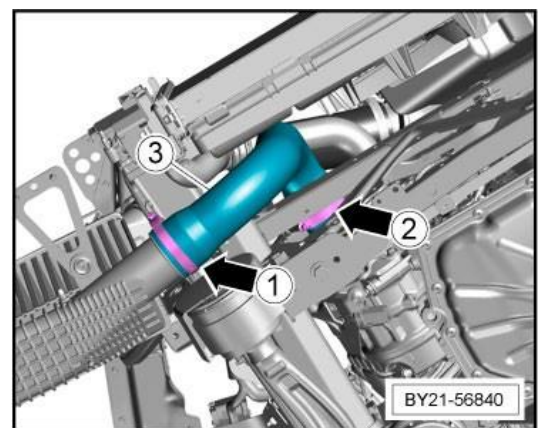
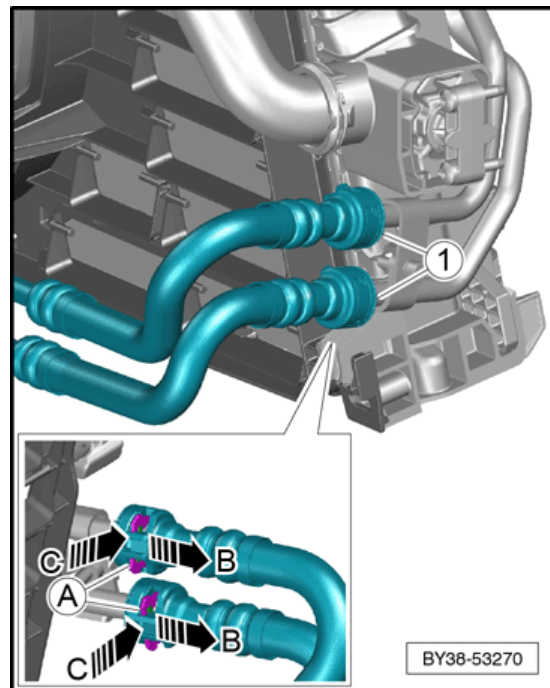
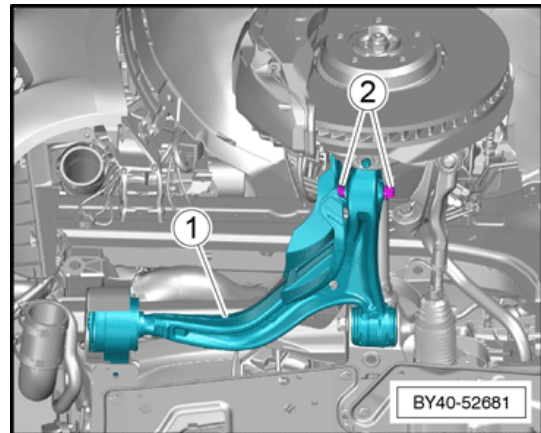

- Mark the position of the front subframe to the body in all accessible areas -1-

Preparing the engine lifting table

Before the sub frame, engine and automatic transmission assembly can be removed from the vehicle, the Hydraulic lifting table -VAS 6131- MUST be prepared with the appropriate special tools.

- Refer to "Engine and automatic transmission hydraulic lifting table - To prepare".

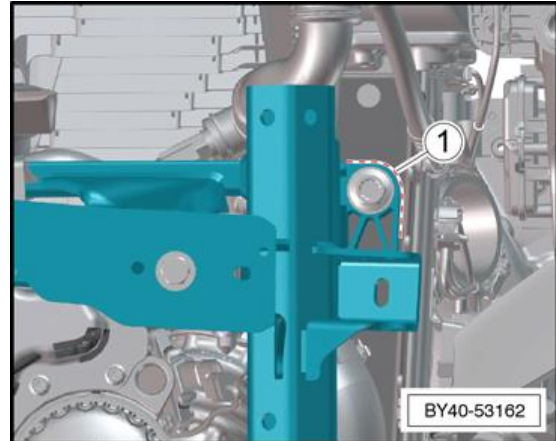

→ Rep.-Gr.10

Lowering the engine and automatic transmission assembly

Position the engine and transmission table under the vehicle in the specified lifting locations.

- In addition to marking the front subframes position, install the subframe locating pins in the instructed places. Refer to "Front subframe" – To fix position.

→ Rep.-Gr.10



Caution

Due to the weight of the engine and transmission assembly, it is important that the vehicle is secured safely to prevent instability of the vehicle on the ramp with the assembly removed.

- On both sides, remove and DISCARD the fixings - 3- from the rear section of the front subframe.



Note

The rearmost fixing will have been removed during the removal of the shear plates.

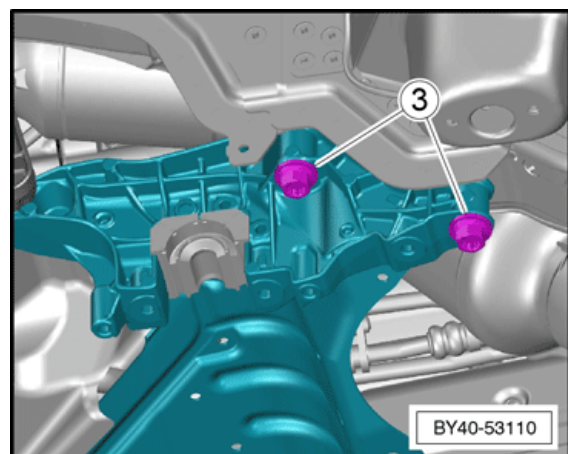

- On both sides, remove and DISCARD the forward
- fixing -1- securing the front subframe section to the body.

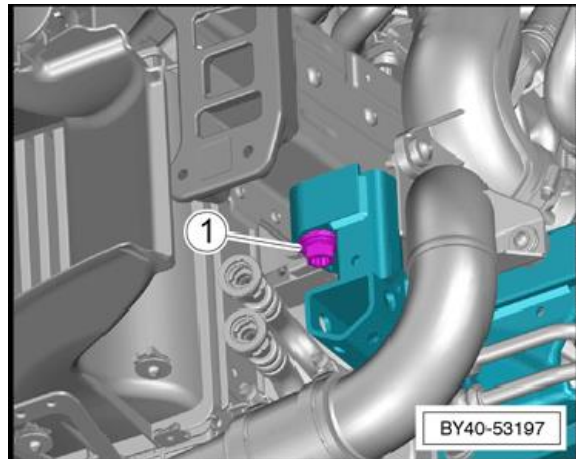

- On both sides, remove and DISCARD the single
- fixing -2- securing the front subframe section to the body.
- Disregard position -1-.

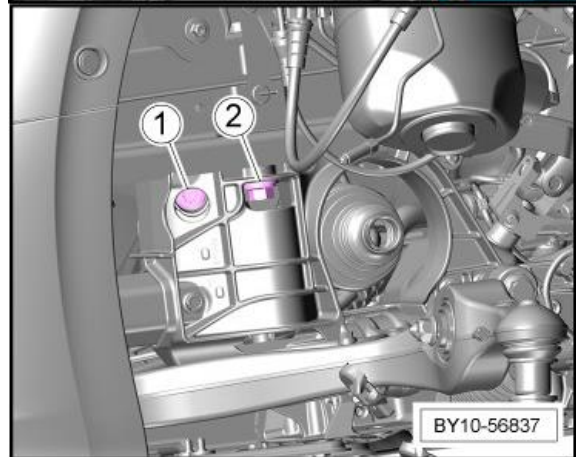

- Remove and DISCARD the fixings -1- that retain the transmission rear crossmember to the body.
- With the aid of an assistant, slowly lower the
- engine and automatic transmission assembly completely out of the vehicle.

 **Caution**

Check all relevant components are disconnected before lowering the engine and automatic transmission assembly, and that none of the engine components are fouling as it is lowered from the vehicle.

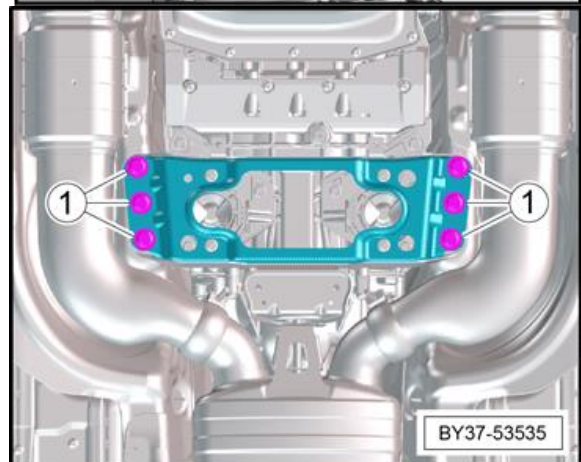

2. Remove exhaust downpipes, heatshields and catalytic converters:

Special tools and workshop equipment required

- ◆ 14 mm spanner -3150-
- ◆ Tool set -T10395A-
- ◆ Tool set for lambda probes -3337-

Removal

- _ Remove the three fixings -A- (8 Nm) and the two fixings -B- (9 Nm) from the heatshields -1 & 2-
- Depress the clips -arrows- in readiness for the
- _ removal of the heatshields -1 & 2- away from the inner heatshields.

Bank 2

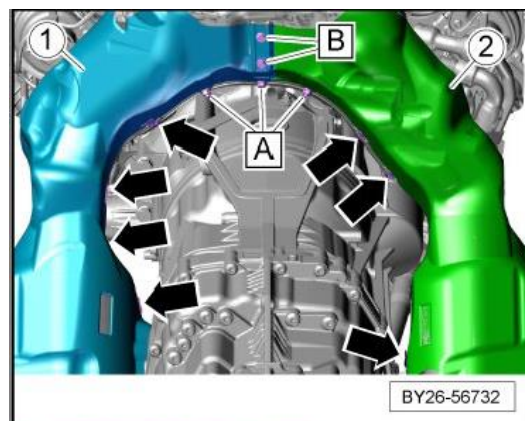

- _ Remove the fixing (8 Nm) -arrow- from the heatshield -1-.

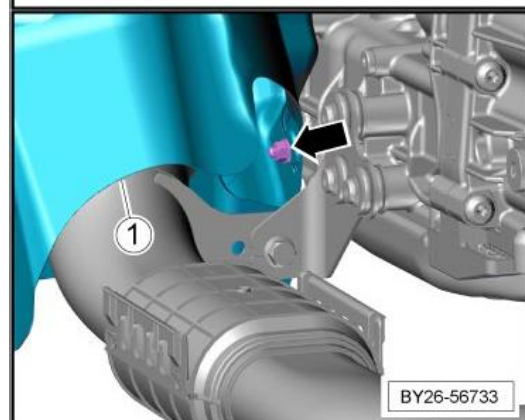

- _ Remove the fixings -A- (8 Nm) and -B- (8 Nm) and depress the remaining clips -arrows- to allow the two halves -1- and -3- to separate away from one another.

i Note

The fixing clip with the arrow marked -C- is obscured from view.

Bank 1

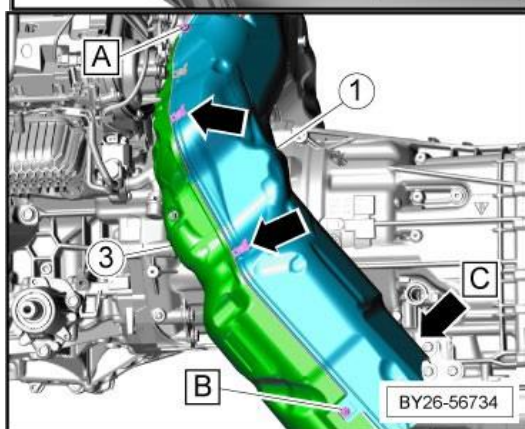

- Remove the fixings -A- (8 Nm) and -B- (8 Nm) and
- depress the clips -arrows- to allow heatshields -2- and -4- to separate from each other

i Note

The fixing clip with the arrow marked -C- is obscured from view.

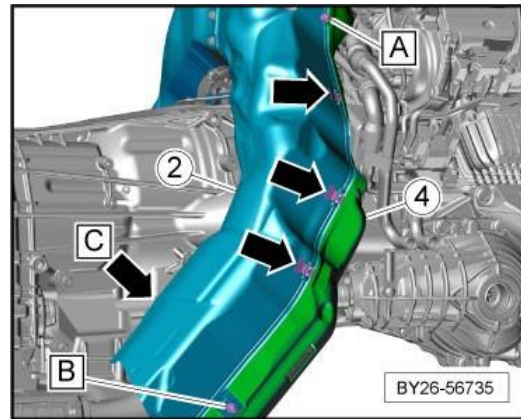

- Remove fixings -1- (8 Nm) and -2- (8 Nm) securing the pressure line -3- to the engine.

Continuation for both sides

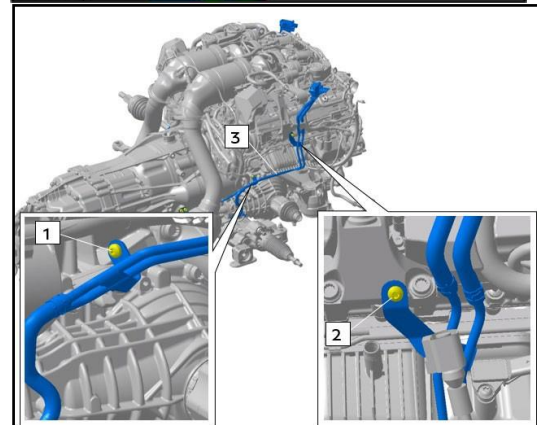

- Release the electrical connection carrier assembly -1- from the subframe.

Separate the electrical connection carrier assembly (two halves) -1-, detach the temperature sensor electrical connection -2- and release the wiring harness.

- Release the hose from the wiring at the clipping point -3-.

Using Hose clip pliers -ASE 451 492 00 000-, release the "Springband" clamp -4- and detach the pressure hose -5- from the "OPF" downpipe.

- Remove the fixing -arrow- securing the heatshield -6-.

- Release the wiring harness -1- at the clipping point -2- on the subframe.

Release the press-stud -arrow- and manoeuvre the heatshield -3- from the "OPF" temperature sensor wiring harness -1-.

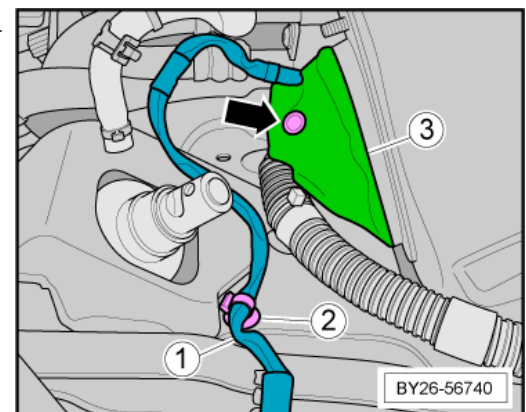
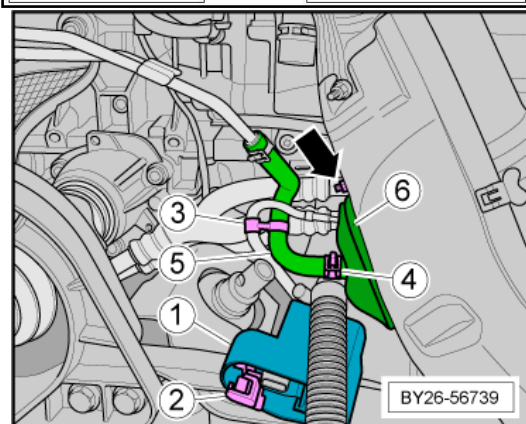

- Using Hose clip pliers -ASE 451 492 00 000-, release
 - the "Springband" clamp -arrow- and detach the hose -2- from the "OPF" stub pipe -3-.
 - Remove the fixing -1- (23 Nm) from the lower support bracket.

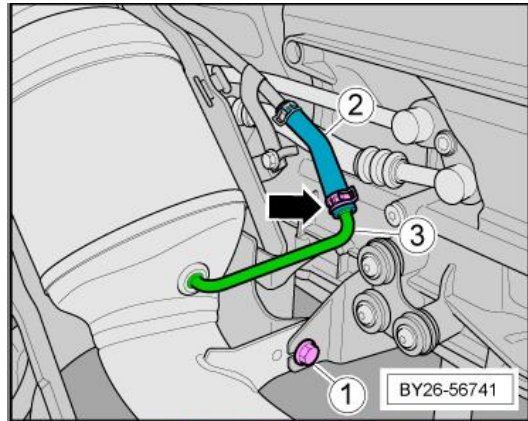

- Remove and DISCARD the fixing -arrow- and clamp and detach the downpipe -1- from the catalytic converter -2-.

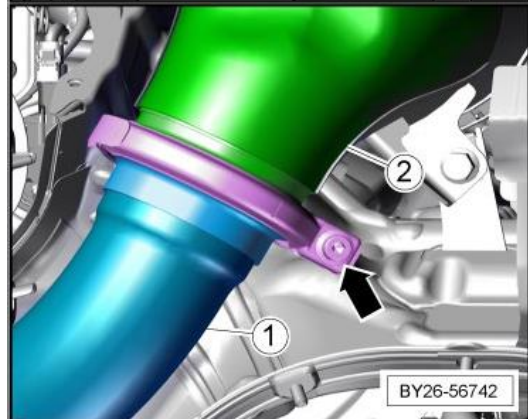

- DISCARD the sealing ring.

- Release the relevant lambda wiring harness plug -1- from its retaining clip -arrow-.

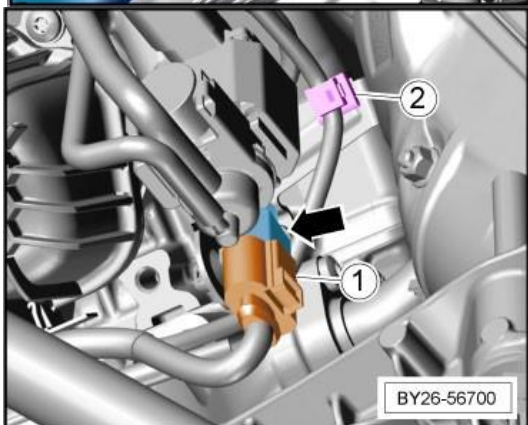

i Note

Bank 1 shown.

It is not necessary to remove the lambda probe from the catalytic converter.

- Unclip the lambda wiring harness from the clipping points.

- Remove and DISCARD the fixing -arrow- (comprising of screw, spring, bush and washer) from the "V-band" clamp -1- between the catalytic converter -2- and turbocharger.

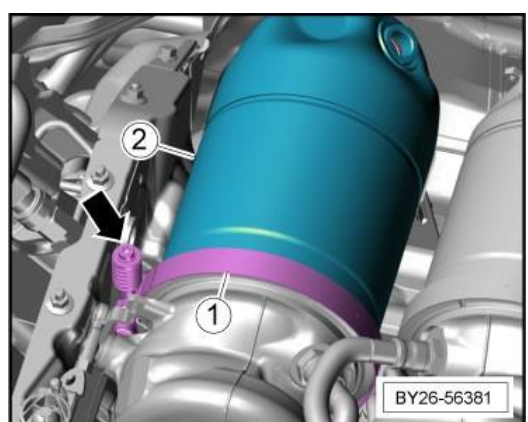

- Undo and remove the two fixings -arrows- (23 Nm) and remove the catalytic converter.

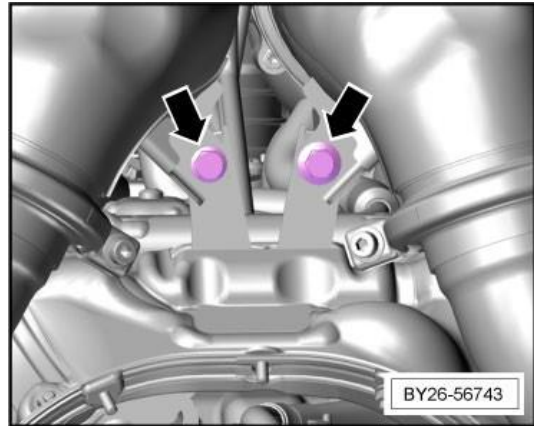

- DISCARD the sealing ring between the catalytic converter and turbochargers.

- On both sides, remove the fixing (20 Nm) -arrow- from the side of the automatic transmission.

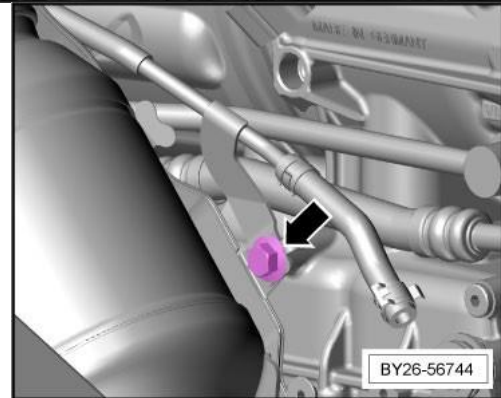

Bank 2 shown, bank 1 fixing is different

- Remove the four fixings -arrows- (9 Nm) from the heatshield -1-.
- Slide the captive nuts -A- upwards from the support bracket to allow the heat shield assembly -1- to slide upwards and away from the engine.

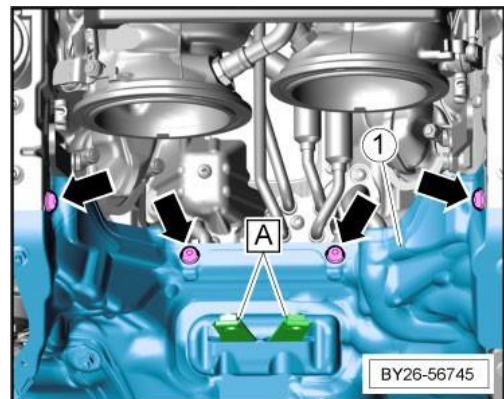

3. Remove rear high-pressure fuel line:

Special tools and workshop equipment required

◆ Torque wrench -VAG 1331 -

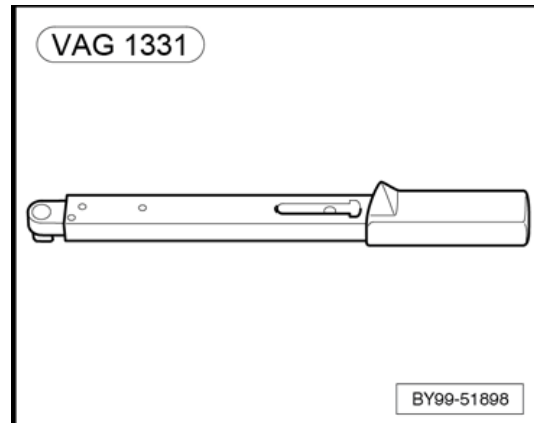

◆ Tool insert AF 17 -VAG 1331/6-

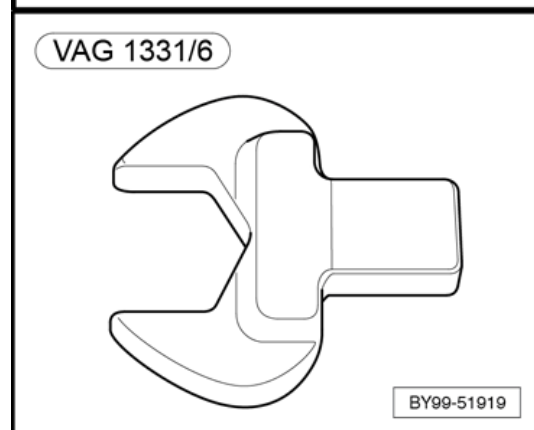

Consumables

Microgleit DF977S lubricant (refer to electronic parts catalogue "ETKA")

Removal

Using a suitable tool, unclip the top part of the harness
– retainer -arrow- to allow the retainer to open up and the harness to be removed detached.

– Remove the fixing -1- (9 Nm), detach the P-clip -2- and move the starter cable -3- to one side.

– Remove and DISCARD the two fixings -4- and detach the catalyst support bracket -5-.

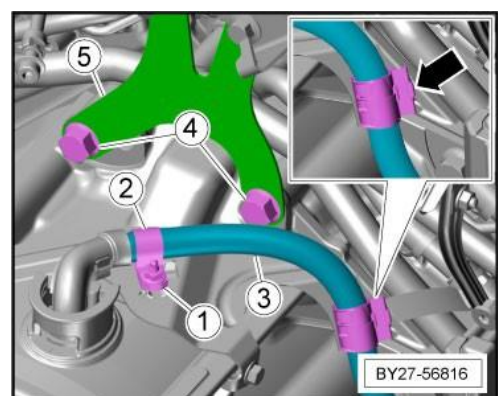

- Remove the fixings -1 to 3- (9 Nm) securing the RH turbocharger coolant pipe.

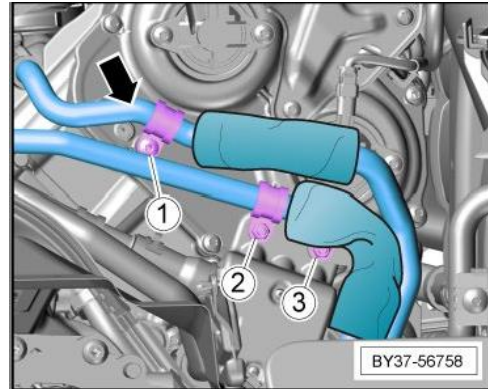

- On the top RH side of the engine, remove the fixing - arrow- (9 Nm), detach the turbocharger coolant pipe -1- and DISCARD the O-ring.

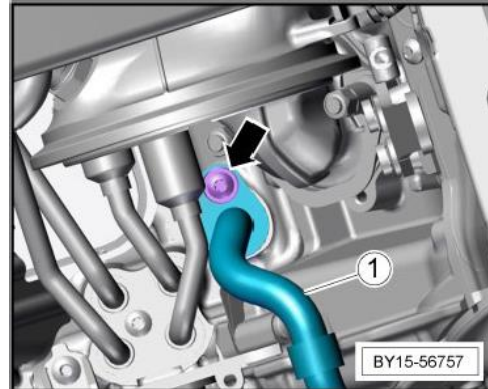

- Remove the two fixings -arrows- (9 Nm) securing the RH turbocharger coolant pipe -1- and the "OPF" pipe -2- (where fitted).

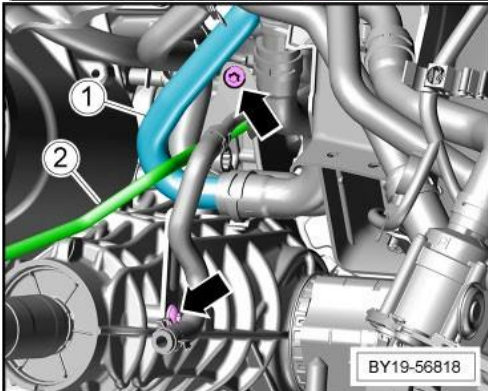

- Remove the fixings -1- (9 Nm) and -2- (1.5 Nm) and detach the heatshield -3-.

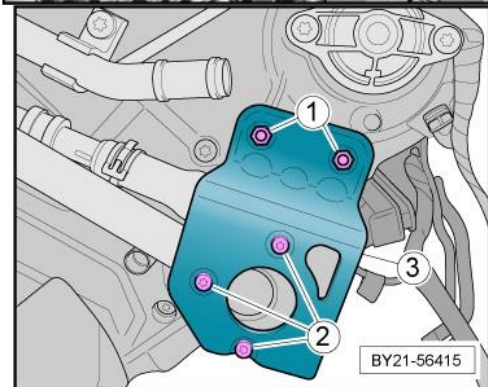

- Remove the fixings -arrows- (9 Nm) and detach the coolant pipe -1-. DISCARD the O-rings upon removal.

Bank 1

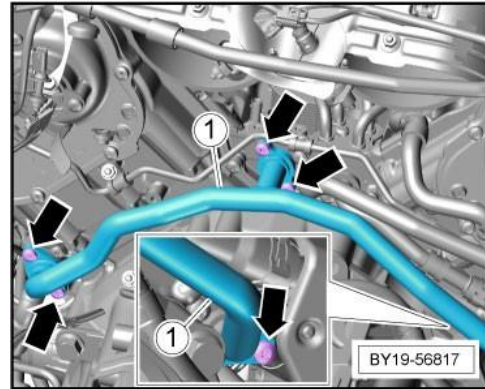

- Release the lambda sensor cable -1- at the clipping point -arrow-.
- Disconnect the electrical connections -2- and release the harness from the clipping points.
- Remove the fixings -3- (8 Nm) and detach the fuel pump crash assembly -4-.

Bank 2

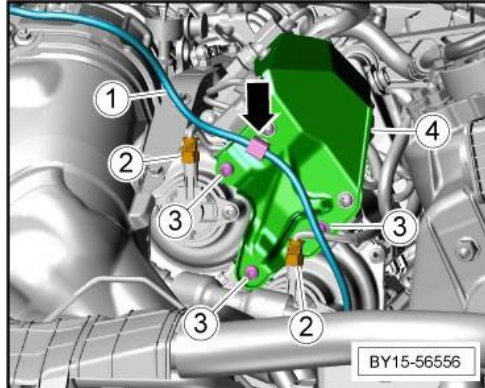

- Remove the three fixings -1- (8 Nm) and detach the fuel pump crash assembly -2-.

Continuation for both sides

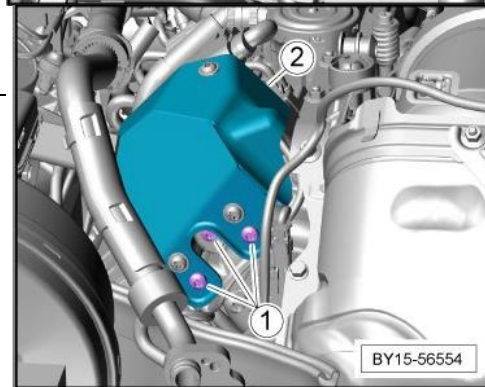

- On the RH side of the engine, disconnect the harness connector -1- from the pressure sensor -2-.
- Remove the fixing -arrow- (9 Nm) securing the pressure sender assembly.
- Undo the union nut -3- securing the high-pressure pipe to the fuel pump.

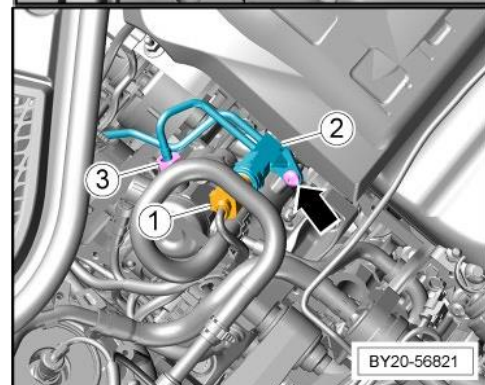

- _ On the LH side of the engine, undo the union nut -4- (8 Nm + 50°).
- Remove the fixing -5- (9 Nm) securing the P-clip.



Note

Disregard items -1, 2 & 3-

- _ Remove the fixings -arrows- (9 Nm) securing the P-clips and detach the fuel link pipe -1- from the engine.

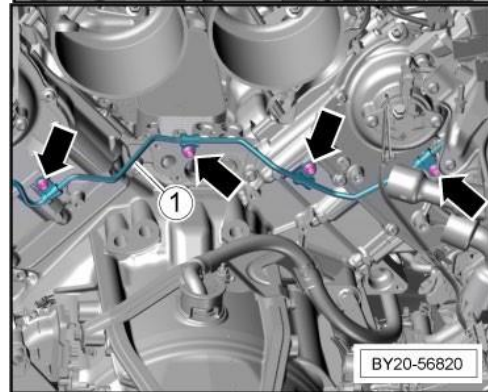
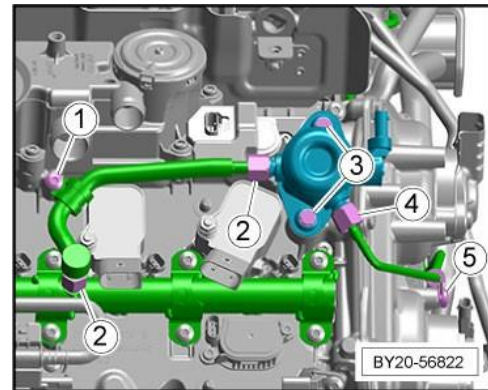

4. Remove upper chain housing covers:



Caution

Dirt and contamination

Risk of damage to units or components

— Protect components from dirt and contamination.

— Secure components to prevent them from falling down.

— Clean or replace dirty components.



Note

The procedure for removing and installing is described for one side as an example. The procedure for the other side is practically identical.

Removal

- Unscrew fixings -2- (9 Nm).
- Press off chain housing cover -1- at a suitable point and set it down on a clean surface.

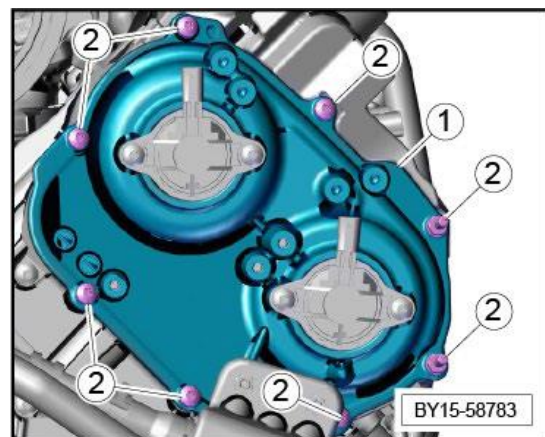

5. Remove oil mist separators:

Removal

- Remove the turbocharger heatshields upper sections.

[Bank 1]

- Disconnect the pipes -1- from the oil mist separator.

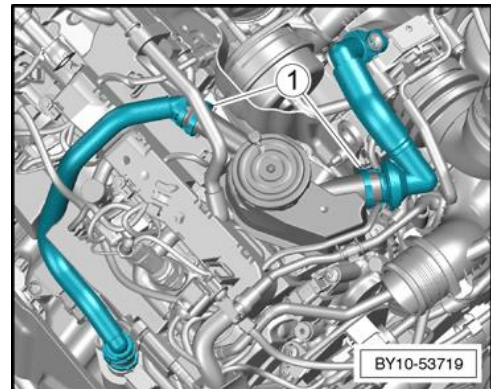

- Loosen the captive fixings -2- (9 Nm) that retain the oil mist separator to the cylinder head cover.



Note

The foremost fixing may be obstructed by sound deadening, suitably peel back the material until the fixing is accessible.

- Remove the oil separator and DISCARD the seal.

[Bank 2]

- Disconnect the vent lines -2- from the oil mist separator.

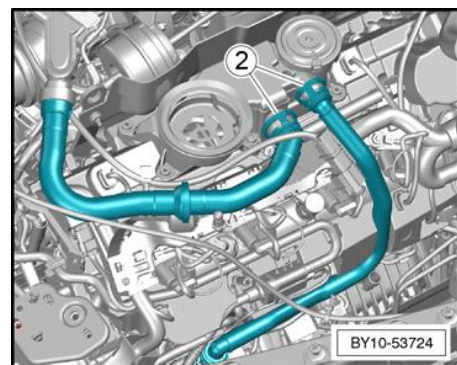
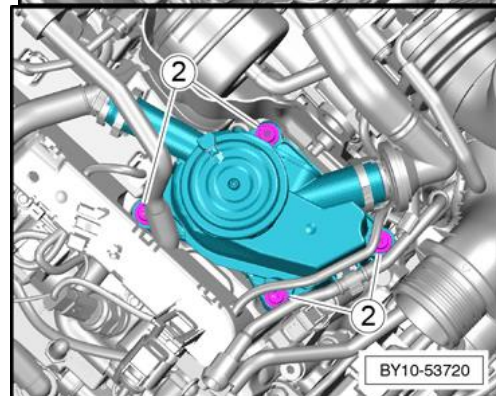

- _ Loosen the captive fixings -2.....7- (9 Nm) that retain the oil mist separator -1- to the cylinder head cover.



Note

Fixings -2, 4 and 6- may be obstructed by sound deadening, suitably peel back the material until the fixings are accessible.

Oil filler cap shown not fitted for illustration purposes only.

- Remove the oil separator -1- and DISCARD the seal.

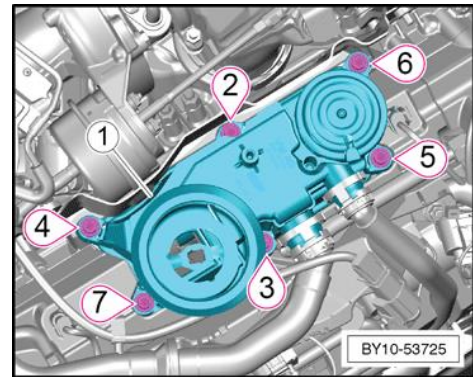

6. Remove ignition coils:

Consumables

Silicone paste -G052565A1- (refer to ETKA)

Removal

|Bank 1|

- _ Remove the fixing -3- (55 Nm), the fixing -4- (20 Nm) and the engine mount bracket -2-.

 Note

Disregard -1-.

- _ Disconnect the lower quick connect -1- and detach the vent line.

- _ Remove the nuts -2- (9 Nm) for the cylinder head harness carrier.

- _ Disconnect ALL harness connectors from the following components;

- ◆ -1- Ignition coils
- ◆ -2- Cylinder deactivation solenoids
- ◆ -3- Fuel pressure sensor
- ◆ -4- Fuel injectors
- ◆ -5- Camshaft position sensor

- _ Carefully move the harness to one side to allow access to the ignition coils.

 *Caution*

Take care not to put too much tension on the harness.

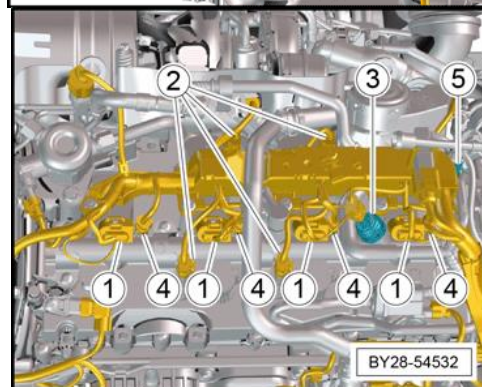
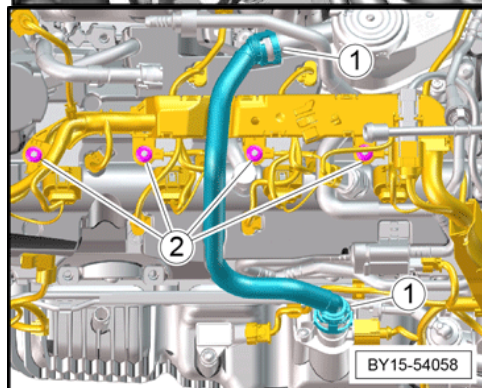
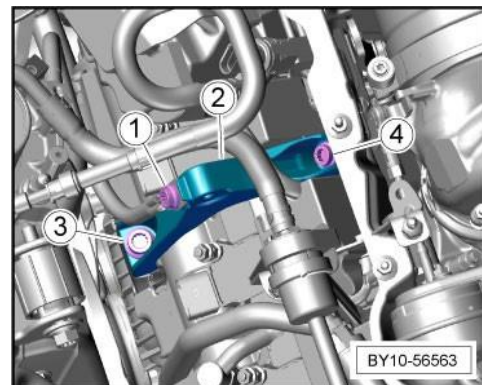

- Remove the studs -1- (9 Nm) for the ignition coils.
- Carefully extract the ignition coil from the cylinder head.



Note

Number each ignition prior to removal to aid installation.

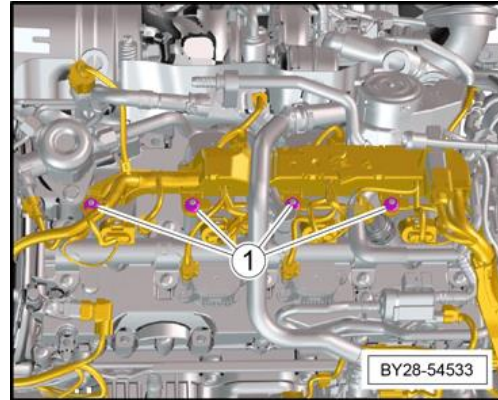

Bank 2

- Disconnect the two electrical connections -2 & 3- and release from their clipping points.



Note

Disregard -1-, previously disconnected.

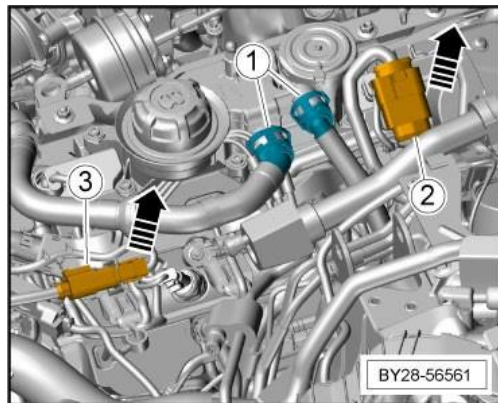

Disconnect the lower 'quick-connect' (not shown) and remove the vent line.

Disconnect the vacuum pipe 'quick-connect' from the intake manifold.

- Disconnect ALL electrical harness connectors from the following components:

- ◆ -1- Ignition coils
- ◆ -2- Cylinder deactivation solenoids
- ◆ -3- Fuel pressure sensor
- ◆ -4- Fuel injectors

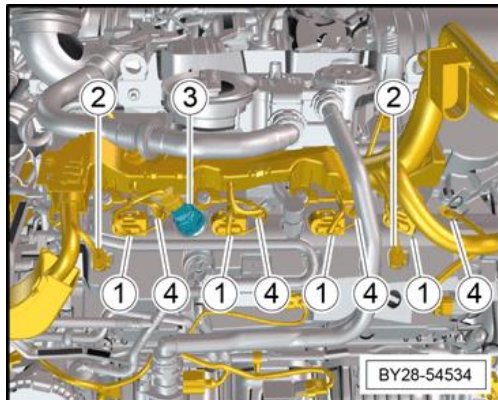

- _ Remove the nuts -1- (9 Nm) and move the harness to one side to allow access to the ignition coils.

 *Caution*

Take care not to put too much tension on the harness.

- Remove the studs -2- (9 Nm) for the ignition coils.
- Carefully extract the ignition coil from the cylinder head.

 *Note*

Number each ignition prior to removal to aid installation.

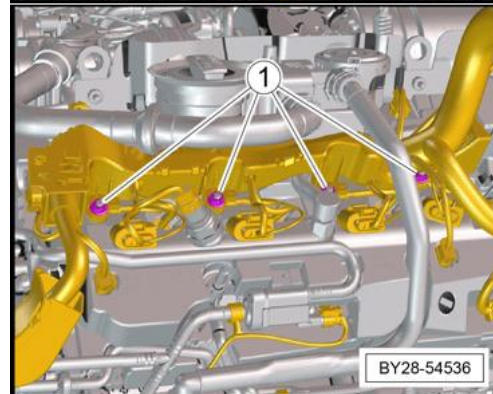
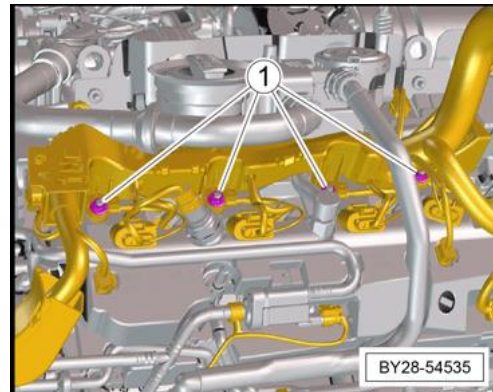

7. Remove high-pressure fuel lines, banks 1 and 2:

Special tools and workshop equipment required

◆ Torque wrench -VAG 1331 -

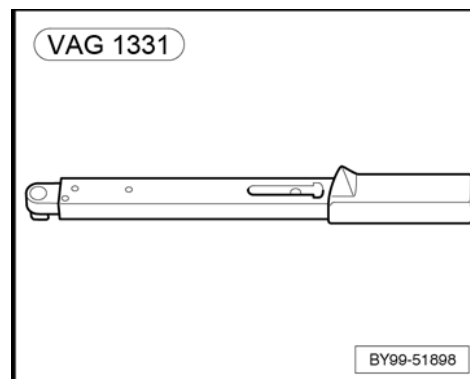

◆ Tool insert AF 17 -VAG 1331/6-

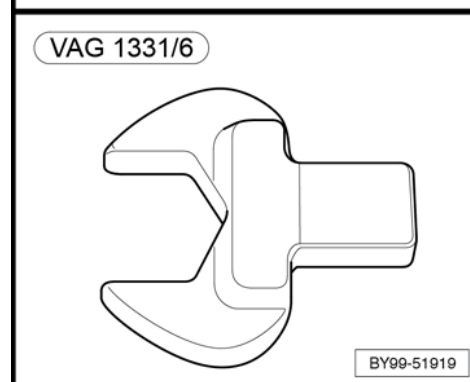

Consumables

Microgleit DF977S lubricant (refer to electronic parts catalogue "ETKA")

Removal

[Bank 1]

- Remove the fixing -1- (9 Nm) for the fuel line clamp.
- Unscrew the union nuts -2- and remove the fuel line.

[Bank 2]

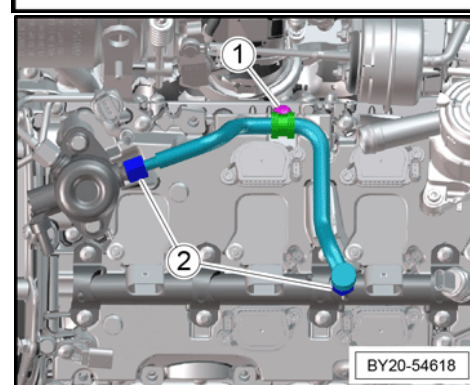

- Remove the fixing (9 Nm) -1- for the fuel line clamp.
- Unscrew the union nuts -2- and remove the fuel line.

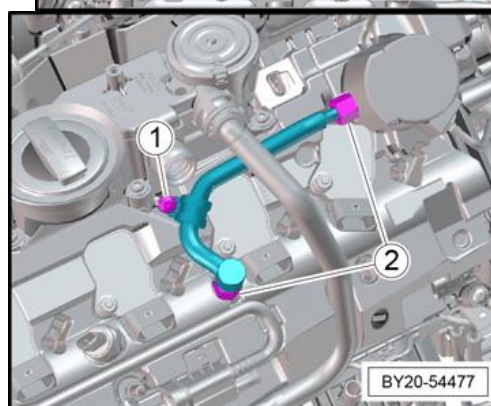

8. Remove high-pressure fuel pumps:

There are two high pressure fuel pumps fitted to the engine:

- ◆ The High-pressure pump -N290- is mounted on the rear top surface of the bank one camshaft cover.
- ◆ The High-pressure pump -N402- mounted on the rear top surface of the bank two camshaft cover.

The removal of the high-pressure fuel pump is the same for both sides of the engine unless stated otherwise.

Special tools and workshop equipment required

- ◆ Torque wrench -VAG 1331 -

- ◆ Tool insert AF 17 -VAG 1331/6-

Consumables

Microleat DF977S lubricant (refer to electronic parts catalogue "ETKA")

Removal

- _ Disconnect the harness connector -1- from the fuel pump.
- _ Disconnect the fuel pipe union -2- from the high-pressure pump.

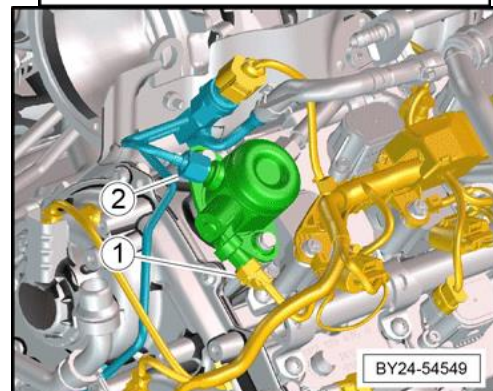
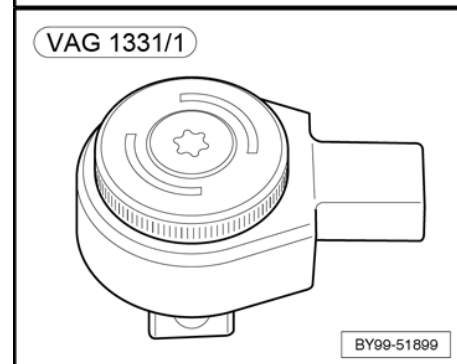
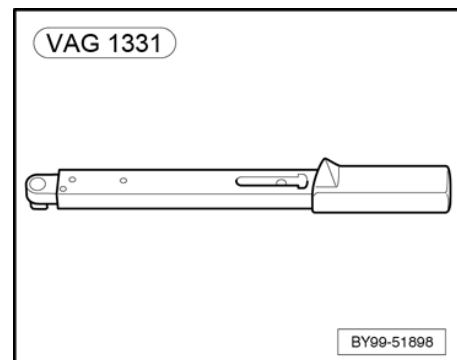

- _ Lift the sound insulation material up to gain access to the fuel pump fixings.
- _ Remove the fixings -3- and carefully withdraw the fuel pump from the camshaft cover.

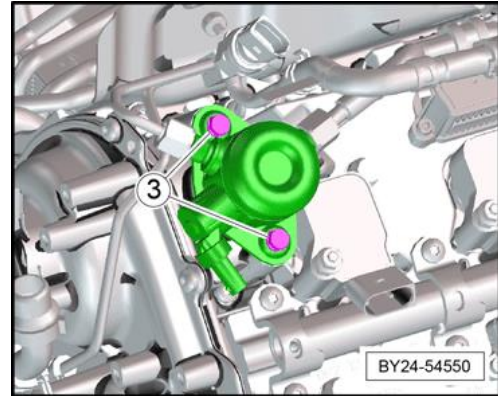

9. Remove fuel rails:

The removal of the fuel rail is symmetrically the same on both banks of the engine unless stated otherwise.

Removal

- Lift the check valve assembly from the guide away from the valve cover -arrow-.

- Remove the sound proof material from the cylinder head -2-.

- Remove the fixings -1.....10- in the sequence shown.
- Detach the fuel rail from the cylinder head, ensuring that the fuel injectors remain seated in the cylinder head.

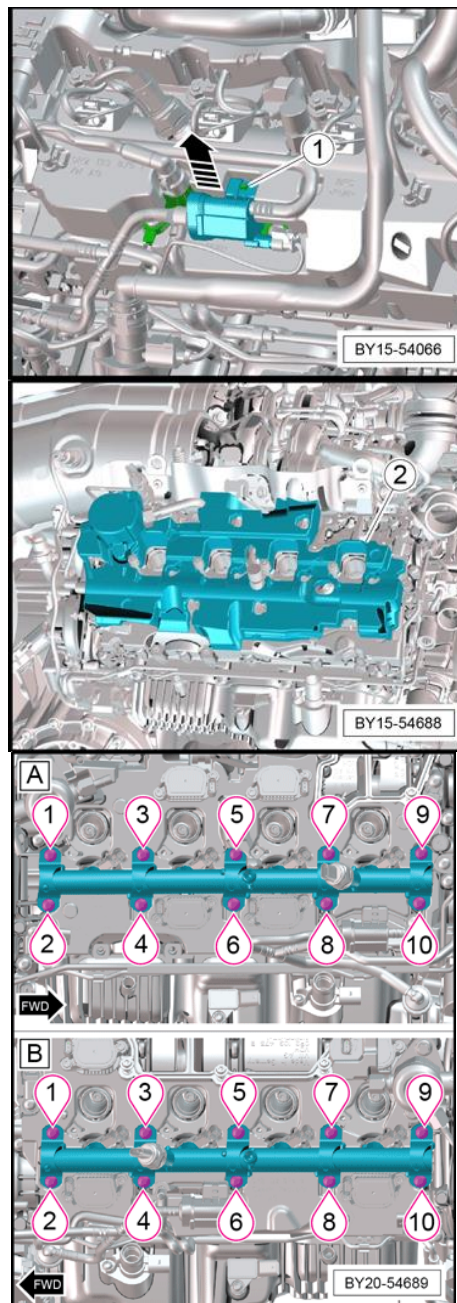

10. Remove cylinder deactivation solenoids:

The cylinder deactivation solenoid system comprises of the following:

- ◆ Camshaft lobe sliding element - which is part of the camshaft assembly and operates on a splined section of the camshaft.
- ◆ CDA activation/ deactivation solenoids (actuators) (4 per engine bank).

Removal

- Remove the fixings -1- (5 Nm) for the relevant cylinder deactivation solenoid.
- Carefully remove the cylinder deactivation solenoid from the cylinder head.
- Repeat for all remaining cylinder deactivation solenoids, noting the locations to aid installation.

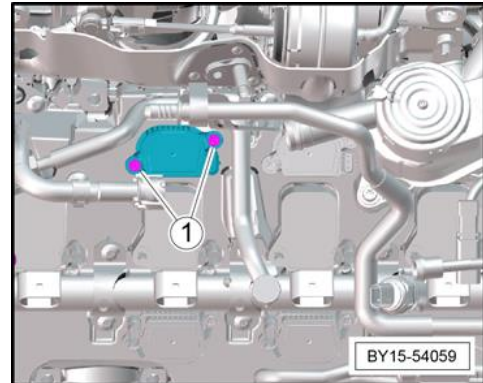

11. Remove fuel injectors:

Special tools and workshop equipment required

Tool set for TSI engines -T10133-

Removal

- Apply Puller -T10133/2A- to the groove of the injector.
- Apply Puller -T10133/16A- over Puller -T10133/2A-, and extract the injector by turning the bolt -1-.
- Repeat for all injectors, taking note of the locations to aid installation.

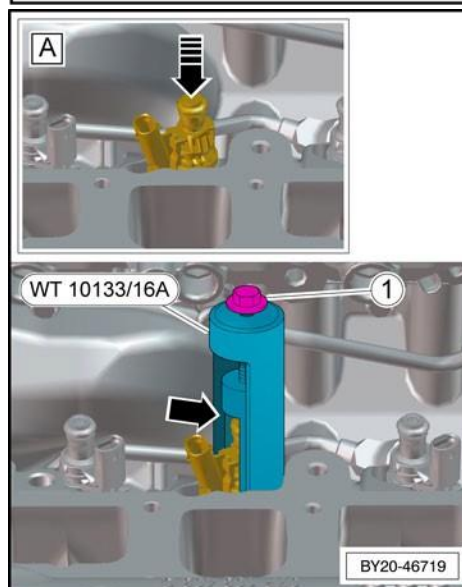
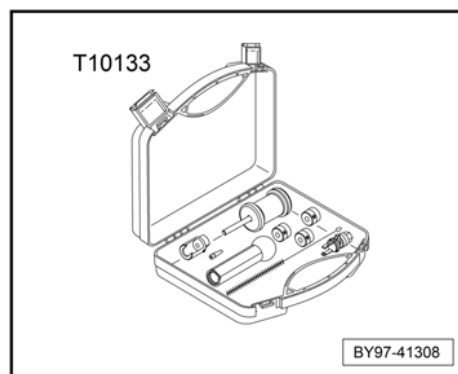

12. Remove mechanical vacuum pump:

The mechanical vacuum pump is located at the front LH side (bank 2) of the cylinder head -arrow-.

Removal

- Remove the fixing -1- retaining the engine harness -2-.
- Detach the quick connect -3- from the pressure tube breather.
- Release the "Springband" clamp -arrow- and detach from the hose -4-.
- Release the pipe assembly -5- from the clipping points for improved access.
- From the top of the vacuum pump, disconnect the vacuum line -2- and the push-on hose -1-.
- Remove and DISCARD the three fixings -3- from the vacuum pump.
- Carefully detach the vacuum pump from the engine.

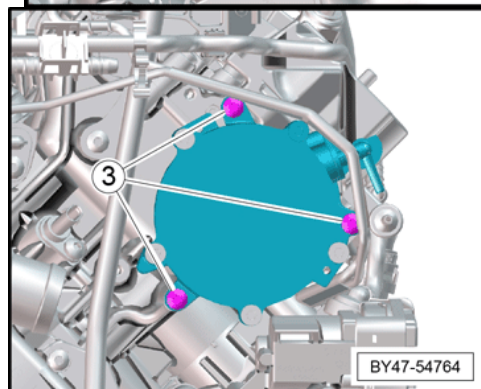
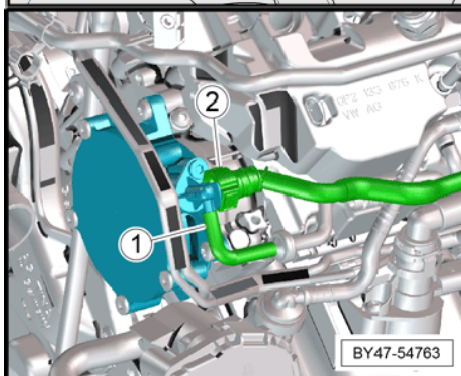
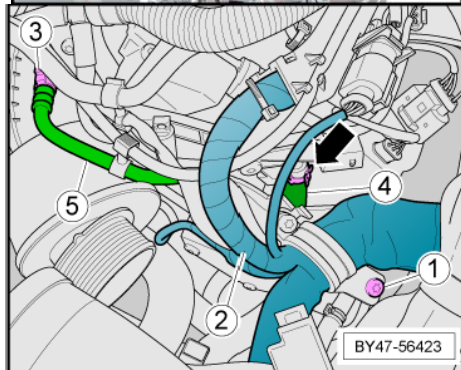
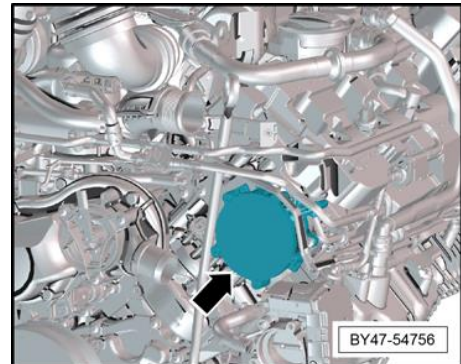

13. Remove pressure pipes:

Special tools and workshop equipment required

Hose clip pliers -ASE 451 492 00 000-.

Removal

LH side (bank 2) only	
-----------------------	--

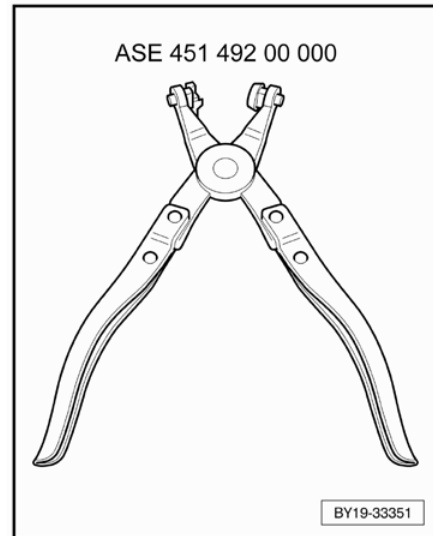

– Pull the breather stub -1- out from the pressure pipe.

Continuation for both sides	
-----------------------------	--

On the appropriate side, release the two captive fixings -

– 2- (9 Nm) and detach the pressure pipe -3- from the centre connecting hose -4-.

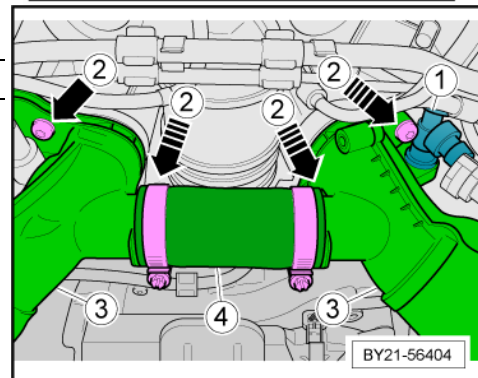

An additional fixing may be fitted dependent on model year.

 *Caution*

Blank off all open ports.

– Remove and DISCARD the "O-rings" -arrows- from the breather stub -1- and the pressure pipe -2-.

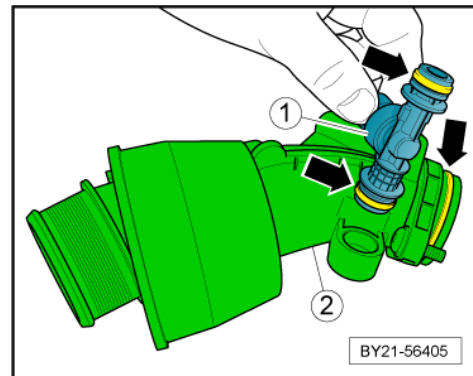

14. Remove camshaft actuators:

The camshaft actuators are located at the rear of cylinder banks 1 and 2, behind the upper chain housing covers.

Special tools and workshop equipment required

- ◆ Counterhold tool -T90001- (not illustrated)
- ◆ Ring wrench insert, a/f 41 -VAS 261 001- (not illustrated)
- ◆ Camshaft clamp -T40331-

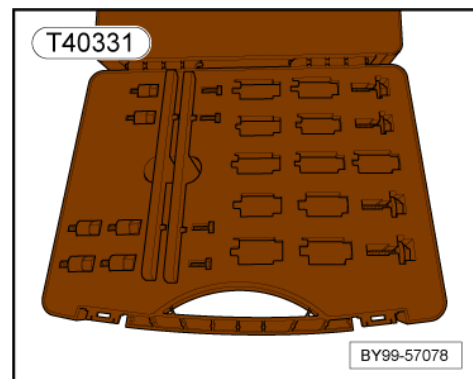

- ◆ Socket E24 -T90000- (not illustrated)
- ◆ Locking pin -T03006-
- ◆ Hook wrench -VAS 261 005- (not illustrated)
- ◆ Counterhold tool -T90002- (not illustrated)
- ◆ Vehicle tester

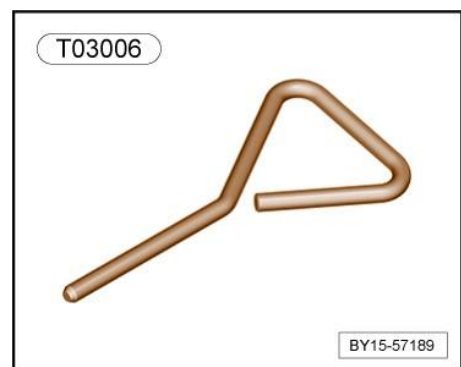

Component overview

Camshaft control

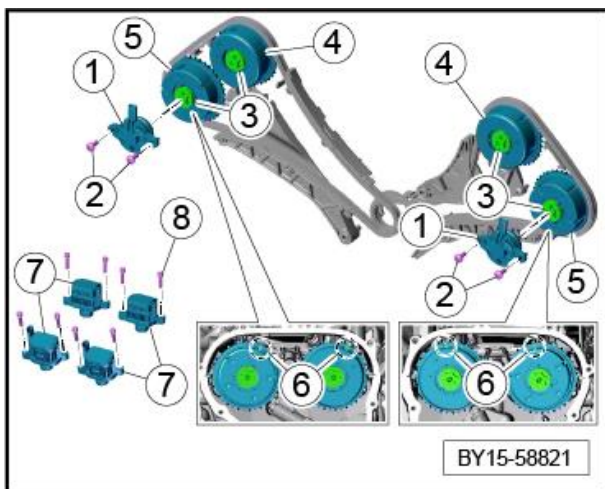

1 - Actuator for camshaft controller

2 - Screws, M6 x 16

Tightening torque: 9 Nm

3 - Central screw for camshaft controller

- ◆ Replace O-ring
- ◆ Initial tightening: 27 Nm
- ◆ Final tightening: 30 Nm +35°

4 - Actuator for outlet camshaft

5 - Actuator for intake camshaft

6 - Installation marking

7 - Valve lift adjustment

8 - Screw, M5 x 20

Tightening torque: 5 Nm

Tightening sequence for central screw for camshaft controller
(item -3-)

Result:	Cylinder bank:	Camshaft:
1.	Bank 2	Outlet
2.	Bank 2	Intake
3.	Bank 1	Intake
4.	Bank 1	Outlet

Preliminary work

- For bank 2 only, remove the dipstick.



Note

Photos taken with a digital camera are helpful with complicated line routing (engine wire harness).

- _ Loosen tank ventilation sensor (USA) or dummy (cylinders 1-4) -1-.
- Unscrew and remove fastening screw -2-.
- Release and disconnect electric plug connection -3-.
- _ Loosen tank ventilation sensor (USA) or dummy -1- together with vent line -5- from holder -4-.

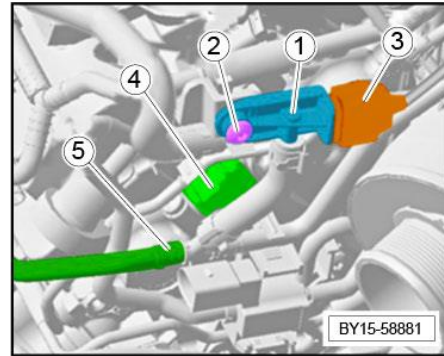

- _ Loosen change-over valve for water pump -3- and remove holder. Ref: Image

Vacuum System for reference:

- 1- Brake booster vacuum pump
- 2- Vacuum line
- 3- Electric change-over valve for water pump
- 4- Control valve for boost pressure control, cylinders 1 to 4
- 5- Control valve for boost pressure control, cylinders 5 to 8
- 6- Brake booster connection
- 7- Vacuum unit connection

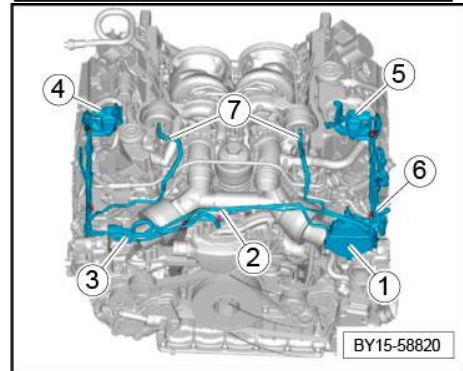

Remove camshaft actuator



Caution

Timing not set correctly

- Risk of engine damage
- Rough running engine
- Loss of engine power
- Do not use force when fitting the staking tool.
- Make sure that the gap is equal on both sides.
- When inserting the staking tools, do not use force to turn the camshafts against any resistance.
- The engine must be exactly at top dead centre.
- The opposite cylinder must be at ignition TDC.



Caution

Dirt and contamination

Risk of damage to units or components

- Protect components from dirt and contamination.
- Clean or replace dirty components.



Note

Do not clean the camshaft controller in a parts washer.
Only the outside can be cleaned using a clean, lint-free cloth.

i Note

Never use the Camshaft clamps -T40331- as a counterhold tool for loosening and tightening the camshaft controllers.

i Note

The Counterhold tool -T90001- can only be inserted at one position. The markings -1 and 2- must line up.

- _ Turn engine clockwise to ignition TDC of cylinder 1. Check markings on crankshaft and actuators.
- Secure camshafts.

- _ Carefully lever out stoppers on the cylinder head cover using a screwdriver.
- _ Screw adapter -1- into the camshaft housing and tighten to 9 Nm.

Cylinder bank 1: T40331/2, Cylinder bank 2: T40331/3

i Note

It may be necessary for another person to carefully position the camshafts at the actuators using Counterhold tool - T90001- and Ring wrench insert, a/f 41 -VAS 261 001-.

Camshaft clamp -T40331- must be inserted.

Cylinder bank 1:

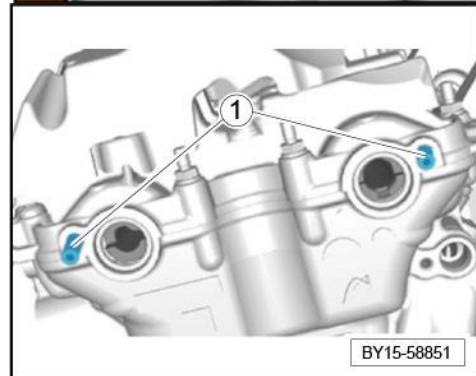
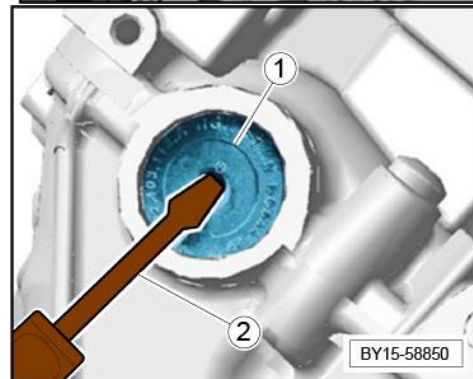
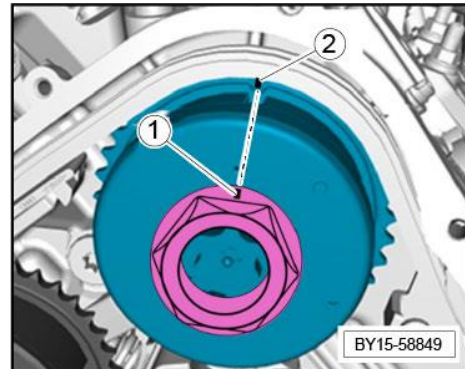

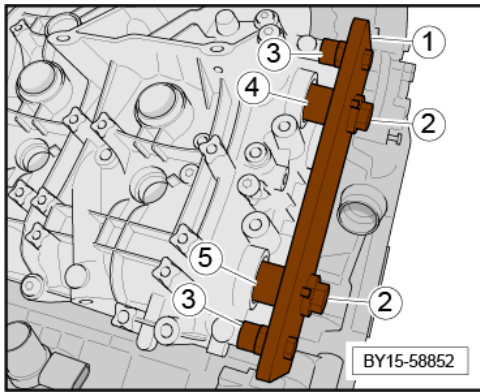

- 1 - -T40331/1- – The letter "A" must be facing you
- 2 - -T40331/9-
- 3 - -T40331/2-
- 4 - -T40331/4- – Outlet camshaft
- 5 - -T40331/6- – Intake camshaft

Cylinder bank 2:

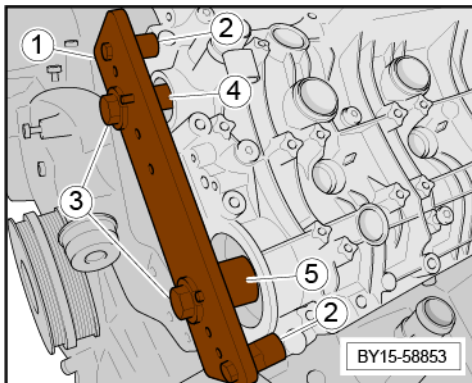

- 1 - -T40331/1- – The letter "B" must be facing you
- 2 - -T40331/9-
- 3 - -T40331/3-
- 4 - -T40331/10- – Outlet camshaft
- 5 - -T40331/8- – Intake camshaft

- Secure the crankshaft at the front of the engine using a suitable 6mm locking pin/drill bit.

 **Caution**

It may be necessary to rotate the crankshaft to fit the tool securing the crankshaft.

If the engine is turned over by hand using the crank damper bolt, it MUST be turned "clockwise" -arrowed- to avoid the possibility of loosening the bolt.

- Loosen and unscrew central valves -1-.
- Counterhold tool -T90001- -2- with Ring wrench insert, a/f 41 -VAS 261 001- -3- must be fitted on the actuators.
- Then loosen central valves -1- using Socket E24 -T90000-.

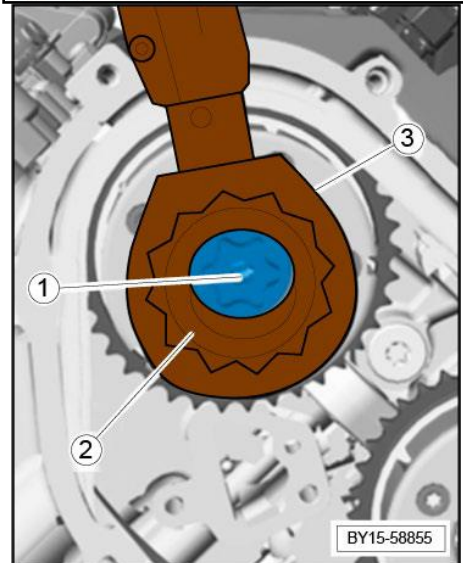
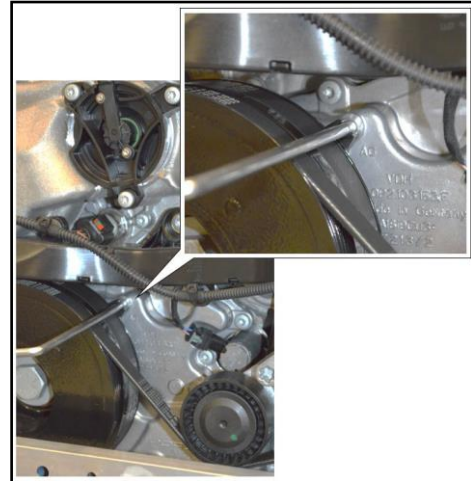

- Fix chain tensioner in place.
- Press the chain tensioner piston back fully. To do this, actuate the tensioning rail by hand.
- Fix the chain tensioner -1- in place using Locking pin - T03006- -3-.

 **WARNING**

If the tensioner pin is removed without chain guide lever in place, the piston & spring may fly out! (depending on version fitted).

- Unscrew central valves and remove actuators from camshafts and from the timing chain.

 **Caution**

Secure the timing chain to prevent it from falling down.

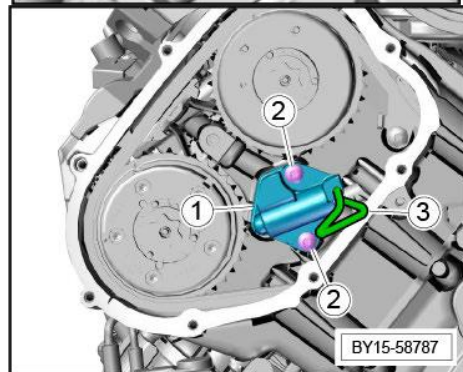

15. Remove cylinder head cover:

The following procedure covers both bank 1 and bank 2 camshaft covers.

Removal

i Note

The procedure for removing and installing is described for one side as an example. The procedure for the other side is practically identical, except where shown.

Bank 1

- Remove the fixings -arrows- (20 Nm).
- Remove the bracket -1-.

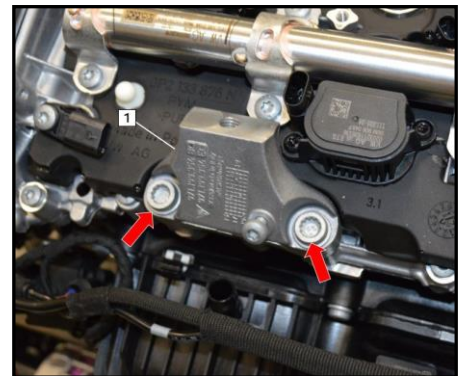

Continuation for both sides

- Remove cylinder head cover -1-.
- Unscrew screws -2- slowly and uniformly from the outside in.
- Remove cylinder head cover -1- (with camshaft clamp fitted) and set it down on a clean surface.

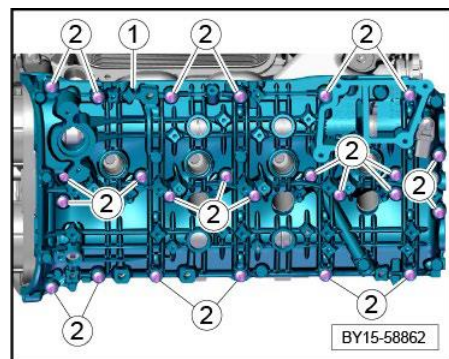

16. Remove valve lifters (hydraulic tappets):

Removal

– If you intend to re-use hydraulic tappets, safety clips and valve levers: Mark allocation of the components using a coloured marker.

- Remove hydraulic tappet -1- and valve lever -2-.
- Take hydraulic tappet -1- with valve lever -2- out of the cylinder head together.

 Note

If you intend to re-use hydraulic tappets and valve levers, check that the components are not damaged.

- Check component allocation and check that all components are fitted.
- Remove hydraulic tappet -2- from valve lever -3-.
- Open safety clip -1- carefully.
- Remove safety clip -1- and hydraulic tappet -2-.

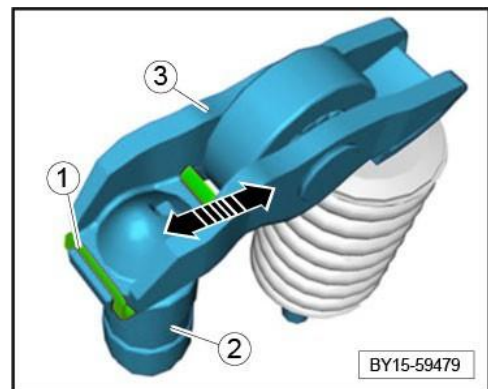
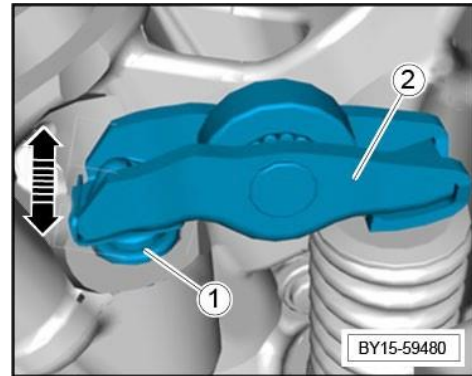

17. Remove spark plugs:

Special tools and workshop equipment required

Spark plug socket (14 mm) commercially available.

Removal



Note

Ensure the area around the spark plugs is free from dirt and debris.

- Using a suitable socket, remove the spark plugs.



Note

When spark plugs are removed, place a suitable clean cloth in the spark plug bore to prevent any dirt ingress.

18. Remove valve springs:

The following procedure is carried out with the engine and automatic transmission removed from the vehicle but with the cylinder installed.

Special tools and workshop equipment required

- ◆ Guide plate -VAS 5161A/38-
- ◆ Removal and installation device for valve keys -VAS 5161A-
- ◆ Valve stem seal puller -3364-
- ◆ Press-on tool -3365-

General information



Note



In the Guide plate -VAS 5161A/38- -1- there are four bore holes -a, b, c, d- for mounting on the cylinder head.

Depending on the installation situation, observe the use of the bores and secure the Guide plate -VAS 5161A/38- with the supplied screws, M5x40 -2-.

- ◆ -E- Intake side
- ◆ -A- Outlet side

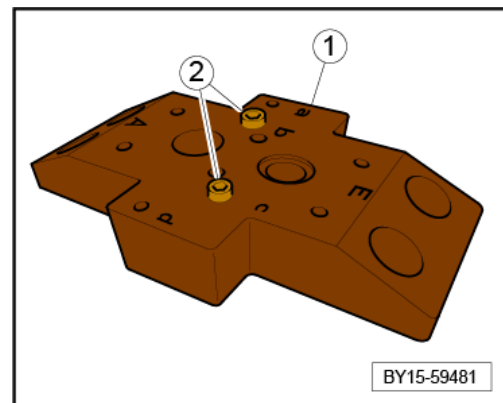

For (Bank 1)

- Using a suitable tool remove the “C-Clip” -1- that retains the “Waistgate actuator rod” to the turbocharger.
- Remove the two fixings -arrows- and remove the waistgate Actuator. This will allow greater access.



Before attempting to remove the valve keys (collets) firstly

Ensure that all galleries in the area being worked are suitably

Covered with lint free cloths, to ensure NO foreign bodies enter the engine .

– Guide plate -VAS 5161A/38- -1- must now be secured on the cylinder head.

Guide plate -VAS 5161A/38- -1- on the cylinder head must be aligned above the relevant combustion chamber. Observe markings "A – Outlet side / E – Intake side" while doing this.

– **It is imperative that all the sealant is removed from the mating faces of the cylinder heads before proceeding further.**

- Insert the two fixings -arrows-, then install two suitable M8 dowel bolts -2- finger tight ONLY.

(The engine cross brace fixings are suitable for this instance)

– Now tighten the fixings -arrows- to 9 Nm.
(for the two rear cylinders, only one securing fixing –arrow- can be used)

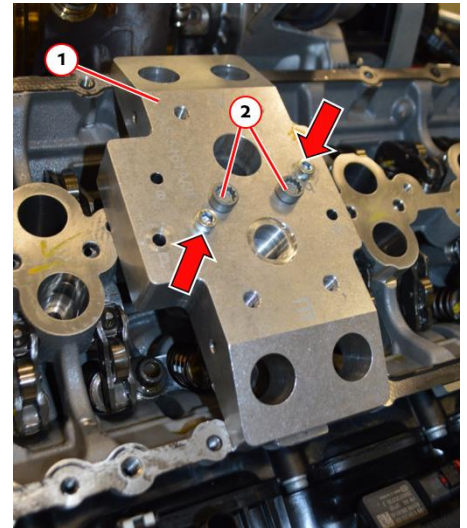

Fit punch -2- -VAS 5161/3A- -2- from tool set Removal

and installation device for valve keys -VAS 5161A- on

– the valve-spring plate and loosen any tight valve keys by tapping them with a plastic hammer.

- Disregard all other position

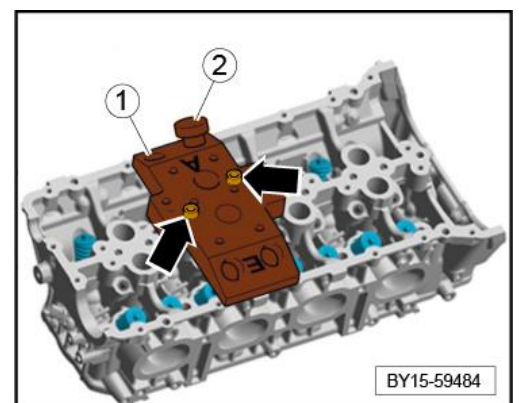

– Screw the sealing pin -VAS 5161/10- -2- from tool set

“Removal and installation device for valve keys” -VAS 5161A-

into the Guide plate -VAS 5161A/38-. Hand tight ONLY.

Screw the hose adapter -VAS 5161A/35- -1- hand-tight into the respective spark plug thread.

Connect compressed air to the hose adapter -VAS 5161A/35- -1-.

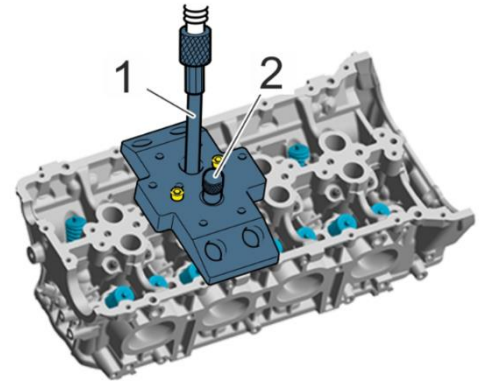

i Note

Minimum pressure: 6 bar

Remove the valve springs using "Removal and installation device for valve keys" -VAS 5161A-.

Screw the retainer -VAS 5161/6- -2- with guided fork and M8 threaded bolt -VAS 5161/5- -3- into the guide plate.

Insert assembly cartridge -VAS 5161/8A- -4- into the bore over the valve spring to be removed.

Engage pressure fork -VAS 5161/2- -1- in the retainer -VAS 5161/6- -2- and press assembly cartridge down.

At the same time, turn the knurled screw -arrow- on the assembly cartridge clockwise until the tips engage in the valve collets.

Turn the knurled screw -arrow- back and forth to press the valve collets apart and capture them in the assembly cartridge. The knurled screw slips in as far as it will go into the assembly cartridge.

Relieve tension on pressure fork -VAS 5161/2- -1- and remove assembly cartridge -VAS 5161/8A- -4-.

Remove valve keys from the assembly cartridge.

Remove valve spring with valve-spring plate and mark installation position. DISCARD spring.

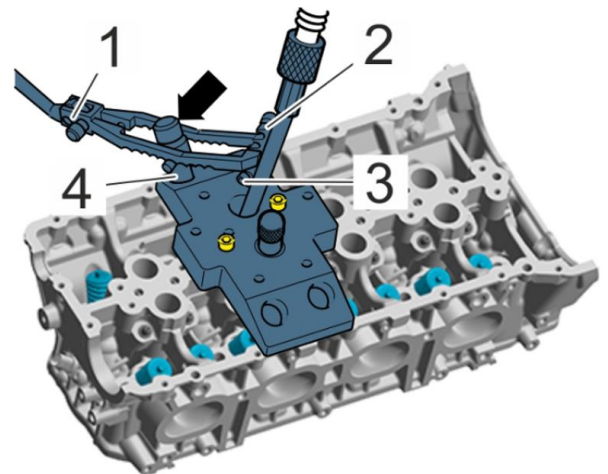

To remove the valve keys from the cartridge

-VAS 5161/8A-

-If the valve keys were removed from the assembly cartridge, they must first be inserted into the insertion device -VAS 5161/18- -1- from the tool

set "Removal and installation device for valve keys"

-VAS 5161A-

-Insert the valve keys into the insertion device -VAS 5161/18- -1- .

-The large diameter of the valve keys must be facing upwards.

-Press the assembly cartridge -VAS 5161/8A- onto the valve keys from above and pick up the valve keys from the insertion device -VAS 5161/18- -1-.

