

# ◀ IMPORTANT UPDATE ▶

*The attached Technical Instructions have been updated. Refer to the details below.*

DATE	TOPIC
January 6, 2022	This Limited Service Campaign has expired as of December 31, 2021

Please review this notification with your staff to assure that all relevant personnel have been briefed regarding this subject.

Thank you for your cooperation.

**TECHNICAL INSTRUCTIONS**  
**FOR**  
**LIMITED SERVICE CAMPAIGN 90K**  
**VVT-i OIL HOSE REPLACEMENT**  
**2008 HIGHLANDER**

The repair quality of covered vehicles is extremely important to Toyota. All dealership associates involved in the LSC process are required to successfully complete E-Learning course SC13A. To ensure that all vehicles have the repair performed correctly; technicians performing this LSC repair are required to currently hold at least one of the following certification levels:

- Certified Engine
- Expert Engine
- Master
- Master Diagnostic Technician

## I. OPERATION FLOW CHART

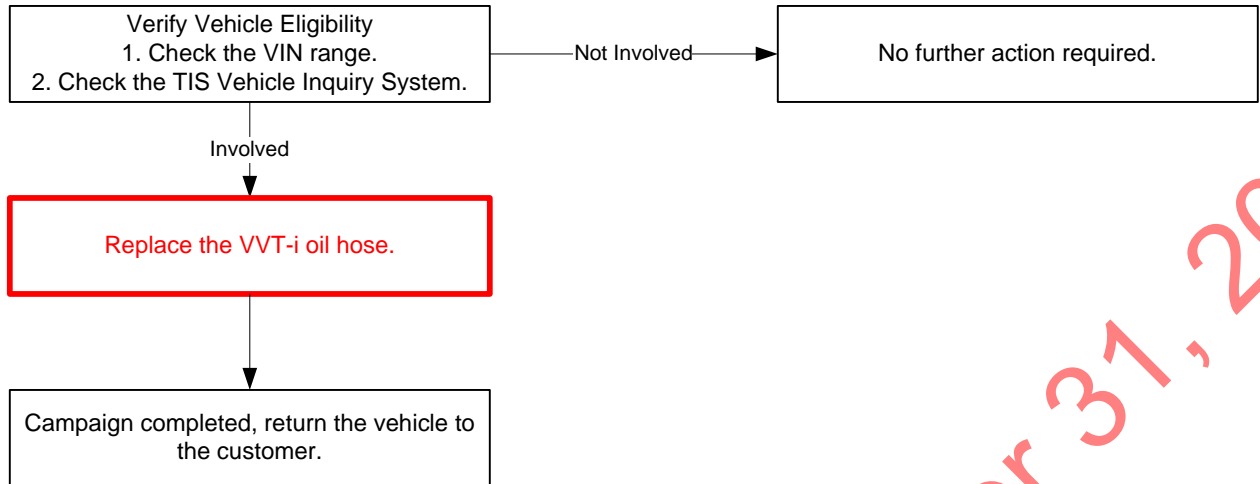

## II. IDENTIFICATION OF AFFECTED VEHICLES

### A. AFFECTED VIN RANGE

Model	WMI	Year	VIN Range	
			VDS	Range
HIGHLANDER	JTE	2008	DS41A	2000147 - 2048686
			DS42A	2000181 - 2048885
			DS43A	2000146 - 2049459
			DS44A	2000303 - 2048181
			ES41A	2000201 - 2084190
			ES42A	2000190 - 2082145
			ES43A	2000188 - 2083204

- Check the TIS Vehicle Inquiry System to confirm the VIN is involved in this LSC and that the campaign has not already been completed prior to dealer shipment or by another dealer.
- TMS warranty will not reimburse dealers for repairs conducted on vehicles that are not affected or were completed by another dealer.

## III. PREPARATION

### A. PARTS

Part Number	Part Description	Quantity
04009-33131	No.1 Oil Hose Kit	1

## B. TOOLS & EQUIPMENT

- Standard hand tools
- Torque wrench
- Angled long nose pliers\*
- Paper or shop towels
- Mirror

\* **NOTE: One angled long nose pliers will be included in the dealer package. Technicians may also utilize one of the following commercially available tools:**

1. Snap-On: 411BCP
2. Matco: PNG111B
3. Mac: P301733

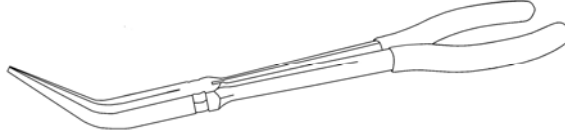

## IV. BACKGROUND

On certain vehicles equipped with a 2GR-FE engine, the rubber portion of the oil supply hose for the VVT-i actuator may degrade over time. This condition may cause oil to leak from the VVT-i oil hose producing abnormal engine noise and the oil pressure light to illuminate.

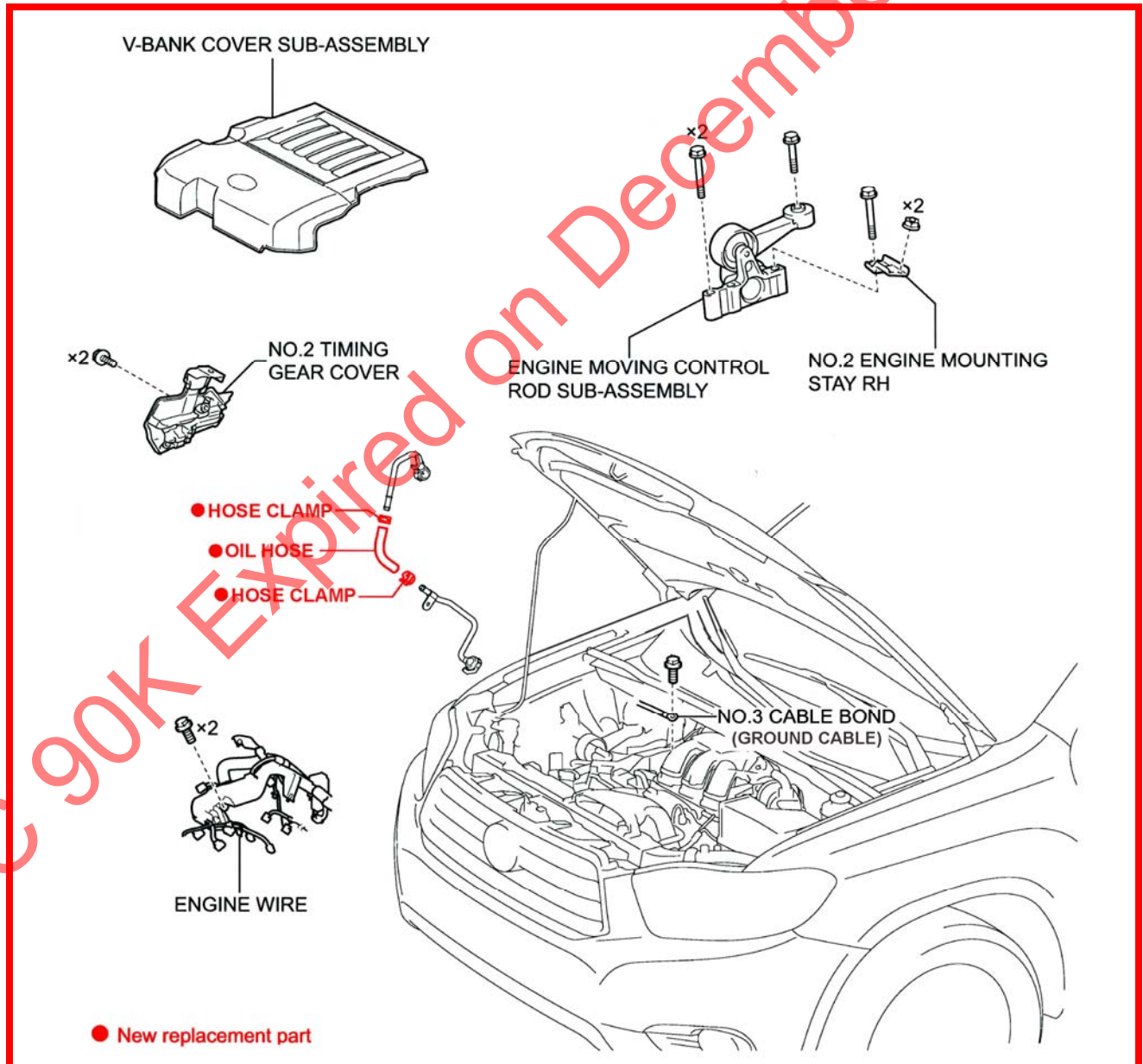

**V. WORK PROCEDURE**

**A. REMOVE OIL HOSE**

**1. CONFIRM IGNITION IS OFF**

- a) Clearly indicate that the engine must not be started during repairs.

■ Copy and place in a visible location when working.



**Supervisor:**

\_\_\_\_\_

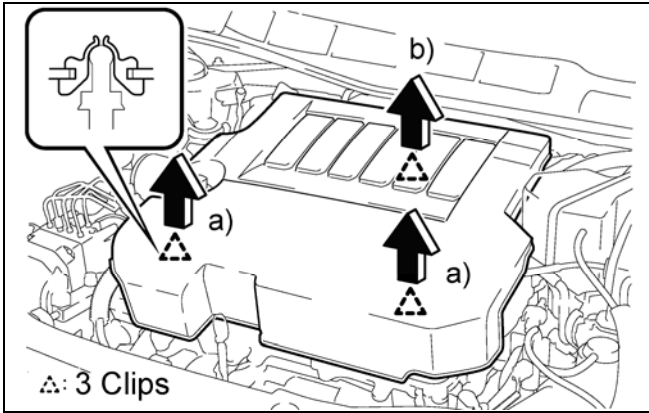

## 2. REMOVE THE V-BANK COVER SUB-ASSEMBLY

- a) Place both hands on the front side of the cover and lift up to disengage the 2 clips.
- b) Place both hands on the back side of the cover and lift up to disengage the rear clip.
- c) Remove the v-bank cover sub-assembly.

### NOTE:

Do not lift the cover's front and back end together; this may damage the clips.

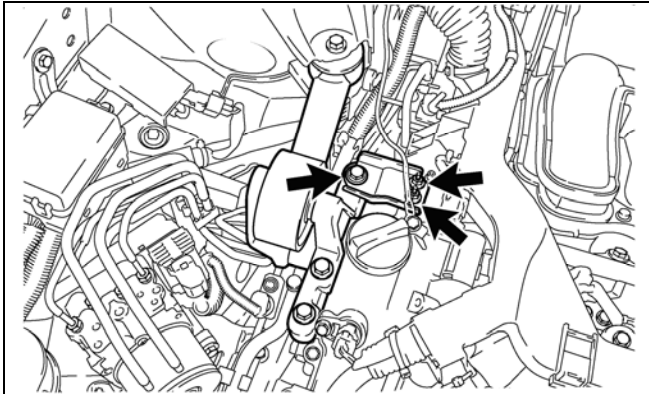

## 3. REMOVE THE NO. 2 ENGINE MOUNTING STAY RH

- a) Remove the bolt, 2 nuts and No. 2 engine mounting stay RH.

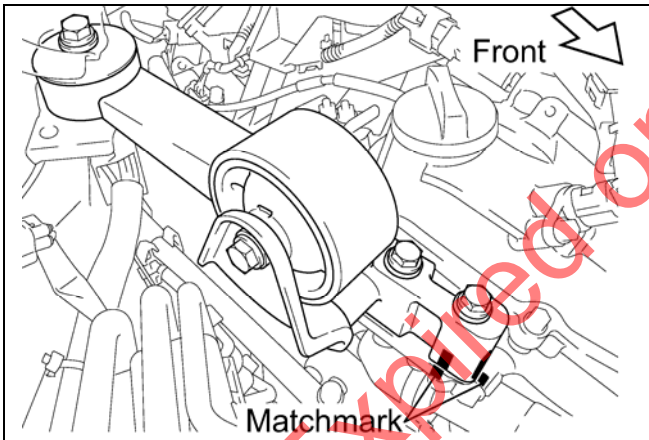

## 4. REMOVE THE ENGINE MOVING CONTROL ROD SUB ASSEMBLY

- a) Mark the sub-assembly as illustrated for reference during re-installation.

### NOTE:

Failure to reinstall the engine moving control rod in the same position from which it was removed may result in additional engine vibration.

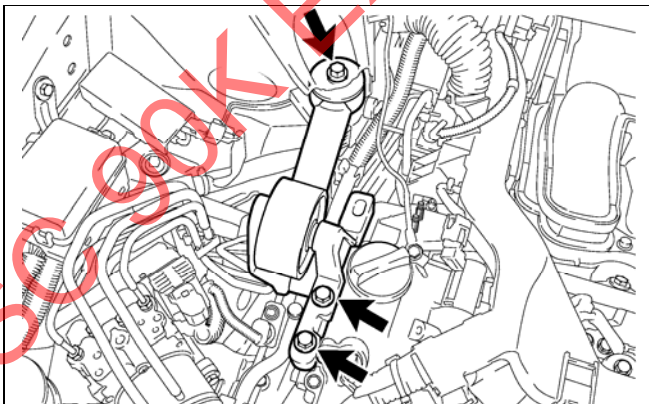

- b) Remove the 3 bolts and engine moving control rod sub-assembly.

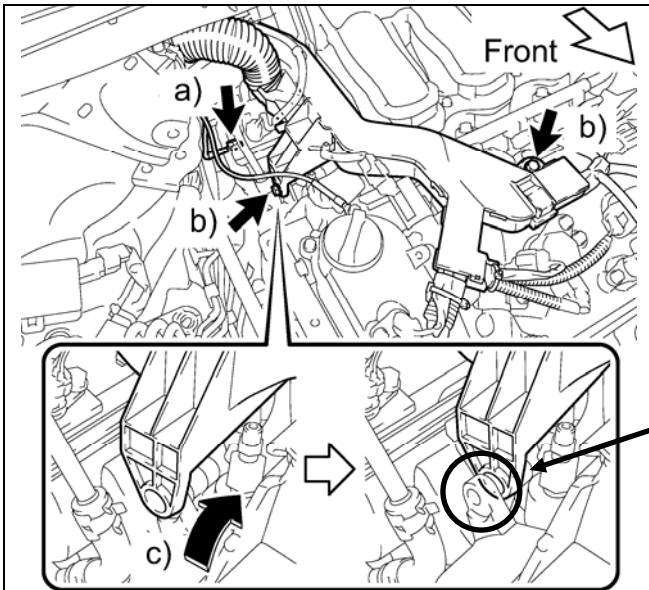

## 5. SEPARATE THE WIRE HARNESS

- a) Remove the bolt and separate the No.3 cable bond (ground cable).
- b) Remove the 2 wire harness protector hold-down bolts as illustrated.
- c) Temporarily reposition the wire harness protector to the opposite side of the mounting tab.

### NOTE:

Avoid damage to wire harness, harness clips and/or wiring. Use care when repositioning the harness for service.

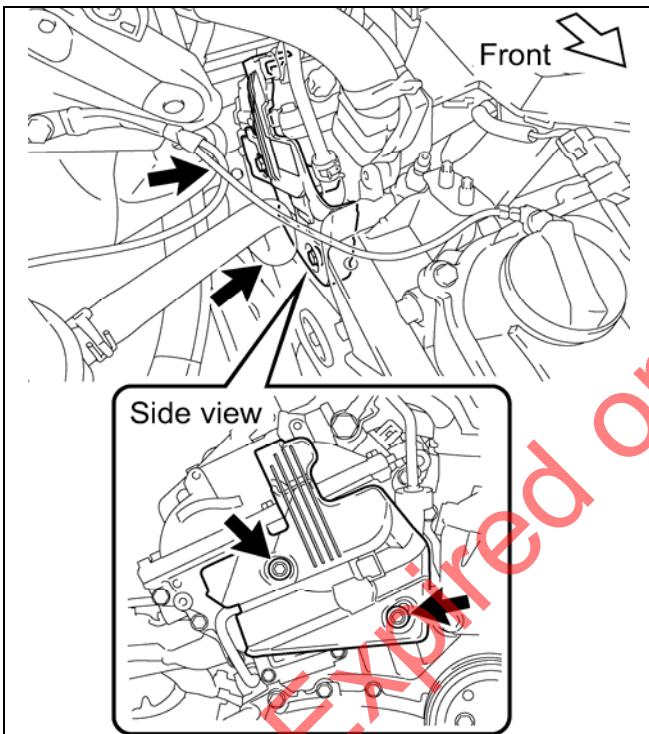

## 6. REMOVE THE NO.2 TIMING GEAR COVER

- a) Remove the 2 bolts.
- b) Remove the No. 2 timing gear cover.



Use care to avoid damage to the Power Steering hoses and VVT-i oil pipe when removing the oil hose.

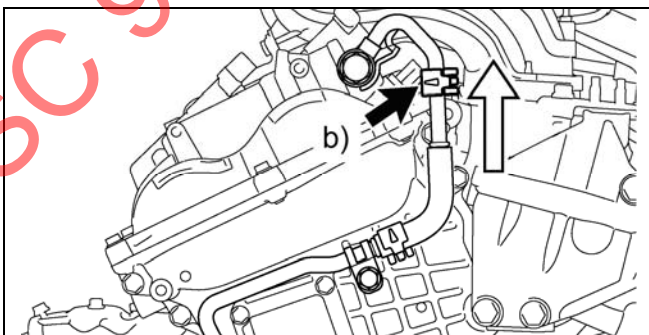

## 7. REMOVE THE OIL HOSE

- a) Place paper towels below the hose before removal to prevent engine oil from dripping onto vehicle components.
- b) Move the upper hose clamp to the upper section of the oil pipe.

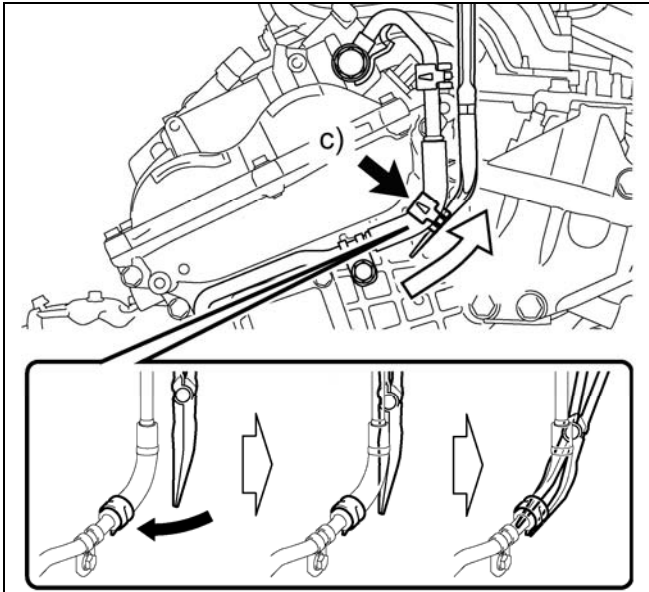

- c) Move the lower hose clamp to the center of the hose.
- d) Remove and dispose the oil hose and the two clamps in a manner by which they cannot be reused.

## B. INSTALL THE OIL HOSE



**Proper positioning of the oil hose is critical to ensure adequate oil flow to the VVT-i actuator and to prevent leakage. Follow instructions carefully!**

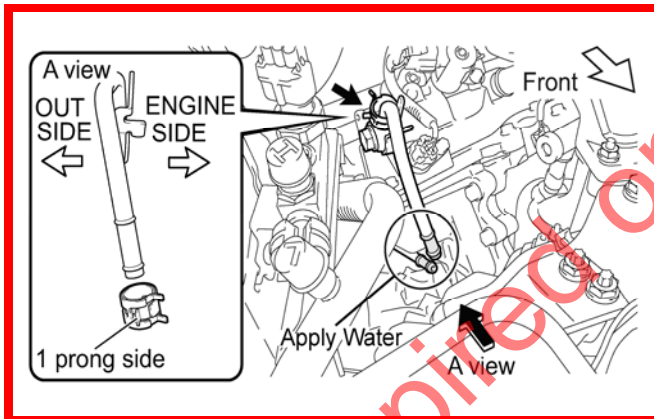

### 1. INSTALL THE OIL HOSE

- a) Place a **NEW** hose clamp on the upper oil pipe as shown.
- b) Clean both edges of the oil pipe with a shop towel and apply water as a lubricant to the oil pipe to assist with the oil hose attachment.

**NOTE:**

**Use only water as a lubricant. Do not apply oil or other lubricants to the oil pipe, this may cause oil leaks.**

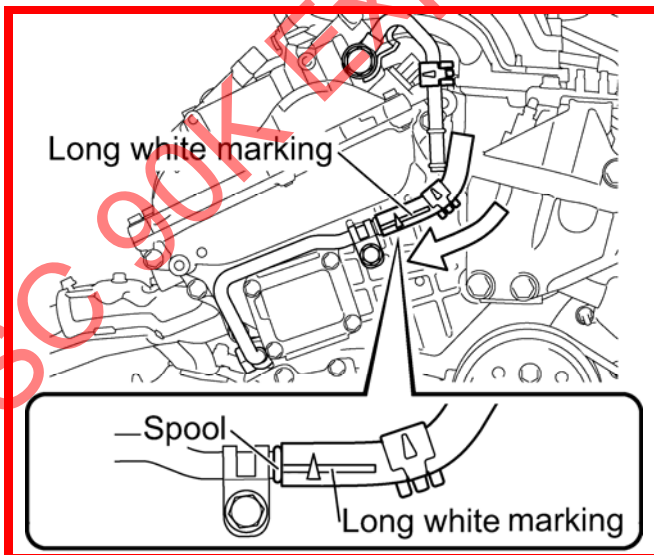

- c) Attach a **NEW** hose clamp on the **NEW** oil hose with the clamp's 2 prong side positioned on the same side as the hose's long white marking.
- d) Install the oil hose's long white marking (lower) side onto the lower pipe until it touches the spool.
- e) Position the long white marking facing away from the engine as illustrated.

**NOTE:**

**The long white marking should face away from the engine.**



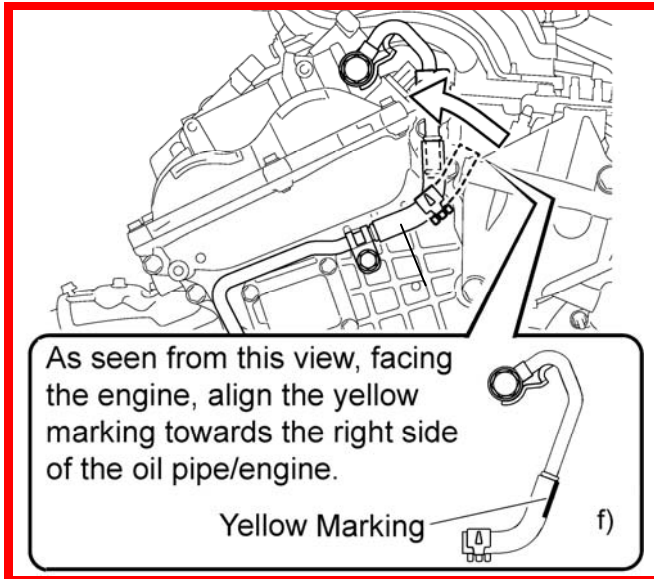

- f) Install the oil hose's yellow marking (upper) side onto the upper oil pipe until it touches the spool. Align the yellow marking as illustrated.

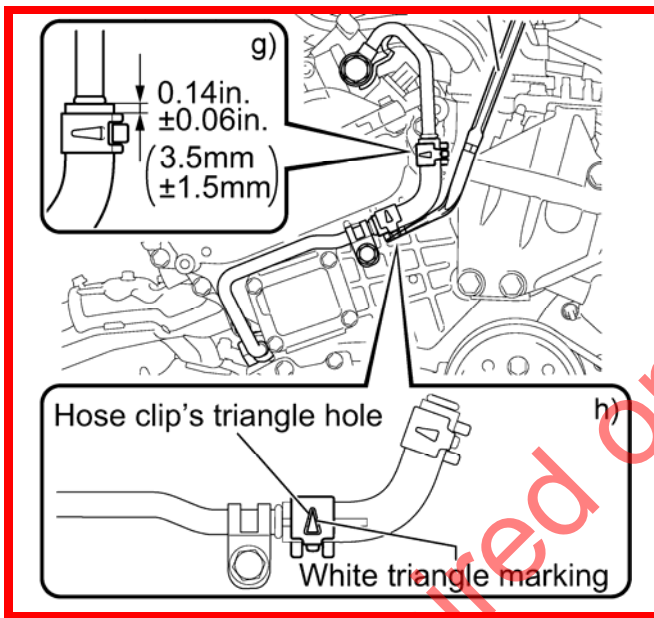

- g) Position the upper hose clamp on the hose as illustrated.
- h) Position and align the lower hose clamp's triangle hole to the white triangle marking on the lower portion of the hose.

**NOTE:**

- Position both upper and lower hose clamps 0.14 in. ± 0.06 in. (3.5mm ± 1.5mm) from the edge of the hose ends.
- Ensure there are no twists in the oil hose.

**Important:**

**Avoid comebacks, visually verify correct installation!**

- i) After verifying correct installation, remove the paper towels from the engine compartment.

## 2. REASSEMBLE ENGINE COMPONENTS BY REVERSING DISASSEMBLY INSTRUCTIONS

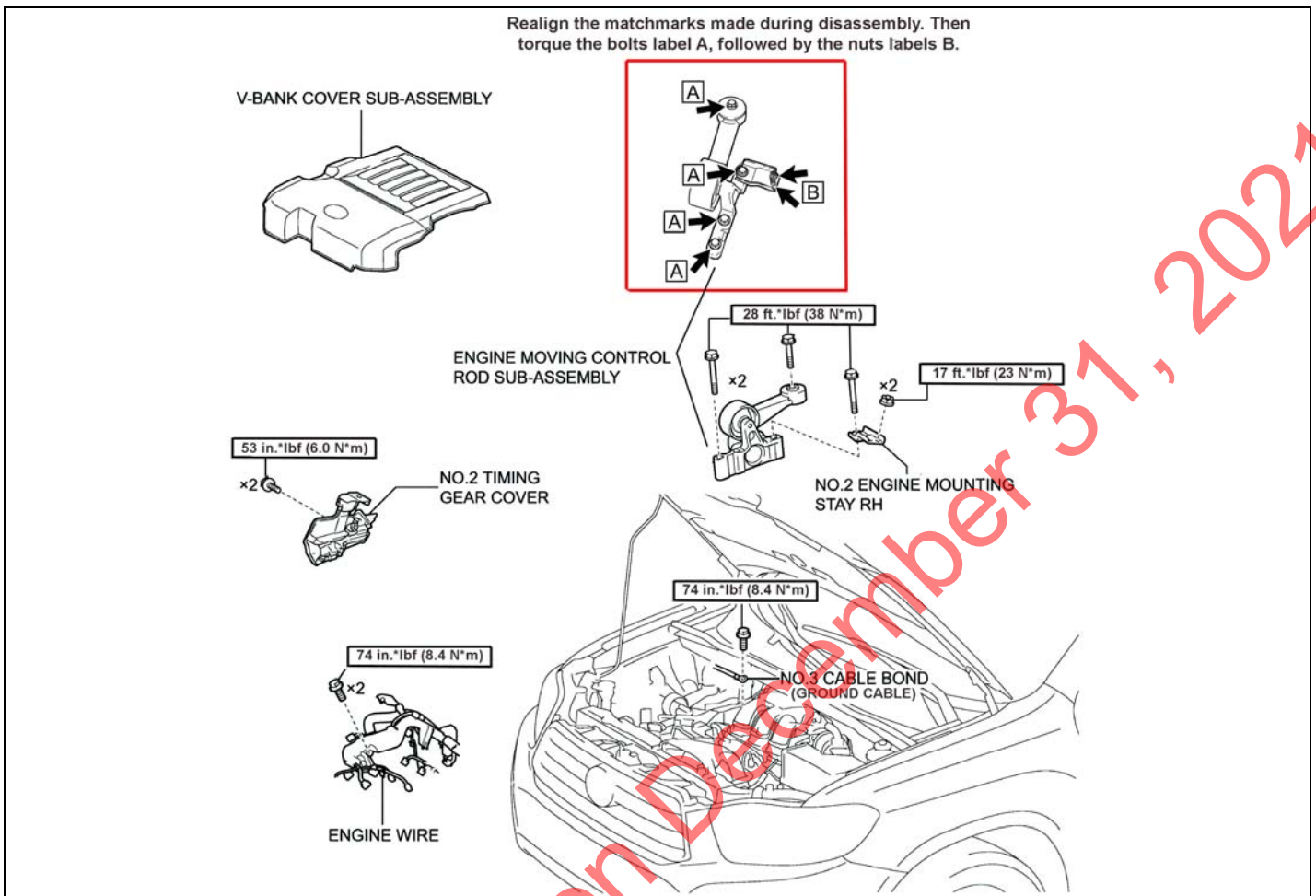

**NOTE:** All necessary torque specifications are located in the illustration above.

### 3. VERIFY THE CORRECT ENGINE OIL LEVEL

### 4. TEMPORARILY RUN THE ENGINE AT 3,000 RPM's, CONFIRM NO OIL LEAKS ARE PRESENT

## VI. APPENDIX

### A. PARTS KIT CONTENTS

Part Number	Part Name		
04009-33131	Kit ,Oil Hose, No.1		
The kit listed above includes the following parts:			
Part Number	Part Name	Q'ty	
15777-31020	Hose, Oil (Cooler)	1	
90466-16003	Clip, Hose (Clamp)	2	

### B. CAMPAIGN PARTS DISPOSAL

As required by Federal Regulations, please make sure all campaign parts (original parts) removed from the vehicle are disposed of in a manner in which they will not be reused.