

TIB 98-020: MY21B MX Tools

3/18/2022

 [Edit](#)  [Clone](#)

TIB 98-020

Section

Tools - 98

Subject

MY21B MX Tools

Whats New Abstract

Information Only – New Level 1 required tools are available to support MY21B MX engines.

Condition

Required tools are available to support MY21B MX engines

Chassis Affected

All MX-11 or MX-13 equipped models

Action

Information Only

These tool kits are Level 1 Required Tools.

Parts

Parts are available for order from PACCAR Parts.

The following are Level 1 Required tools:

Quantity	Part Number	Description
1	2163517PE*	MX-11 Common Rail HPV Service Bracket
1	2163519PE Or Heel Bar)	MY21B Fuel Injector Puller OR heel bar (equivalent to Snap-On 2050)
1	1961366-901PE*	Fuel Filter Module Outlet to Lift Pump Inlet Pressure/Flow Fuel Monitoring Hose
1	2203512PE	MX-13 EGR Outlet Sensor Boss Plug
1	2306435PE	MX-11 Engine Rotator Bracket Spacer Update
1	2154147PE**	NA Valve Spring Disassembly Tool
<p>*Tool included in 1961366PE. If 1961366PE was not purchased, it may be necessary to purchase 1961366-900PE kit as 1961366-901PE will not be available individually.</p> <p>**Tool is backward compatible with all MX engines EPA2013 and newer. This tool supersedes 1809922PE and applicable updates. If the dealer has 1809922PE on hand in working condition, it is not necessary to purchase 2154147PE. The current stock of 1809922PE will be sufficient in servicing MY21B MX engines.</p>		

Background

For the complete serviceability of MY21B MX vehicles, new tools are available.

[MX-11 common rail HPV service bracket 2163517PE](#) is available for purchase through PACCAR Parts. This tool is to be used in conjunction with 2124310PE for use on MY21B MX-11 engines. To attach, remove the 2 allen head bolts securing bracket head to bracket, and install bracket head 2163517PE using same 2 allen bolts.

2163517

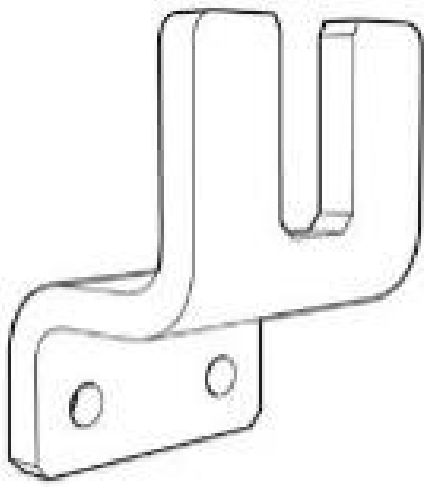

T06168

[MY21B fuel injector puller 2163519PE](#) is a level 1 required tool. A heel bar tool (equivalent to Snap-On 2050) can be used instead of 2163519PE when used carefully, to avoid damaging the body of the injector and avoid prying against internal engine components. See image below for proper heel bar placement for injector removal. If an injector is difficult to remove with heel bar, revert to 2163519PE tool to remove.

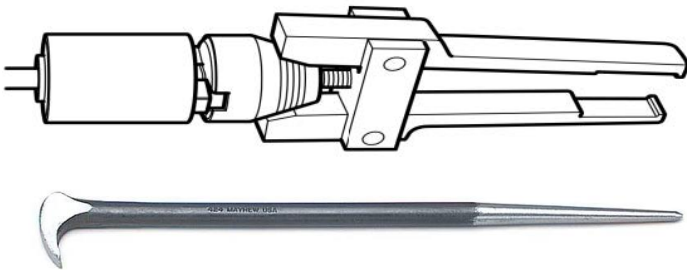

[Fuel filter module outlet to lift pump inlet pressure/flow fuel monitoring hose 1961366-901PE](#) is available for purchase through PACCAR Parts. (Note: 1961366-901PE will not be available as an individual part. If the master kit 1961366PE has not been purchased, it will be necessary to purchase kit 1961366-900PE). This part has been manufactured to have Poka-Yoked VOSS Fitting.



[EGR sensor boss plug 2203512PE](#) is available for purchase through PACCAR Parts. This plug is to be used with MY21B MX-13 engines when using tool 2124348PE due to interference between the EGR sensor and tool.

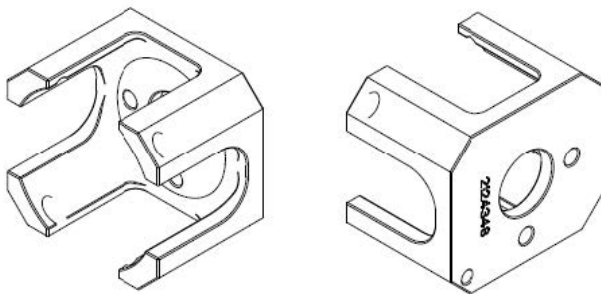
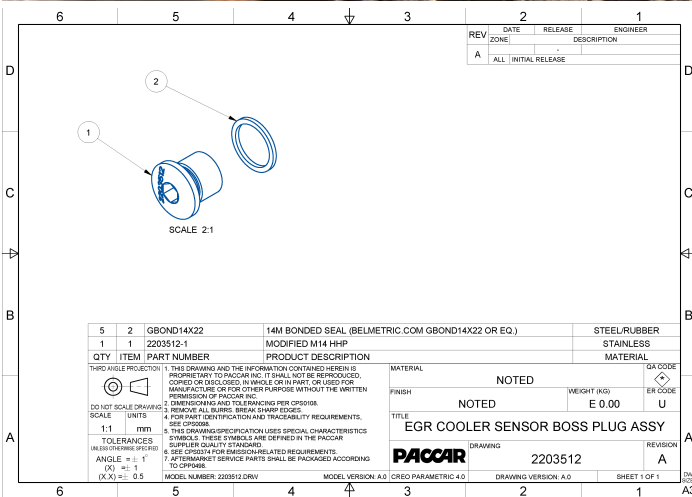

[MY21B MX-11 shim kit 2306435PE](#) is available for purchase through PACCAR Parts. This kit is to be used in conjunction with 1903046PE. When using, the long rectangular shim (red in image below) included in 1903046PE will not be used with the MY21B engines and will be replaced with the circular shim included in the 2306435PE kit. (Note: washers must be used with bolts to keep threads from bottoming out. Bolt thread

engagement must be 1.5X bolt thread diameter. These are 14mm, so thread engagement must be 21mm. Add or subtract washers to ensure proper engagement.)

NOTE: THIS KIT CONSISTS OF FASTENERS AND A SHIM TO BE USED IN CONJUNCTION WITH ENGINE ROTATOR ADAPTER 1050AMPE FOR PACCAR M7210 MX-11 APPLICATION. NOTE: THE RECTANGULAR SHIM DELIVERED WITH 180992PE IS NOT REQUIRED FOR THE M7210 MX-11 APPLICATION.

1	5	2206435-2	LABELLED MESH ZIPPER BAG (NOT PICTURED)	NYLON
1	4	2206435-1	M7210 MULTI-ROTOR SHIM	STEEL
2	4	BH14X1.5X70F/LW	M74X1.5 70MM CLASS 10.9 PHCS (BELMETRIC BH14X1.5X70F/LW)	STEEL
1	3	BH14X1.5X40F/LW	M74X1.5 40MM CLASS 10.9 PHCS (BELMETRIC BH14X1.5X40F/LW)	STEEL
1	2	BH14X1.5X46F/LW	M74X1.5 46MM CLASS 10.9 PHCS (BELMETRIC BH14X1.5X46F/LW)	STEEL
4	1	WPH14X1W	M14 HARDENED STEEL WASHER (BELMETRIC WPH14X1W)	STEEL

QTY: 1 PER UNIT
 PART NUMBER: 2206435-1
 PRODUCT DESCRIPTION: M7210 MULTI-ROTOR SHIM
 MATERIAL: STEEL
 FINISH: NOTED
 TOLERANCES: E 0.01 U
 DIMENSIONS: SEE DRAWING
 TITLE: MX ROTATOR ADAPTER SHIM KIT
 PACCAR PARTS 2306435
 SHEET 1 OF 1

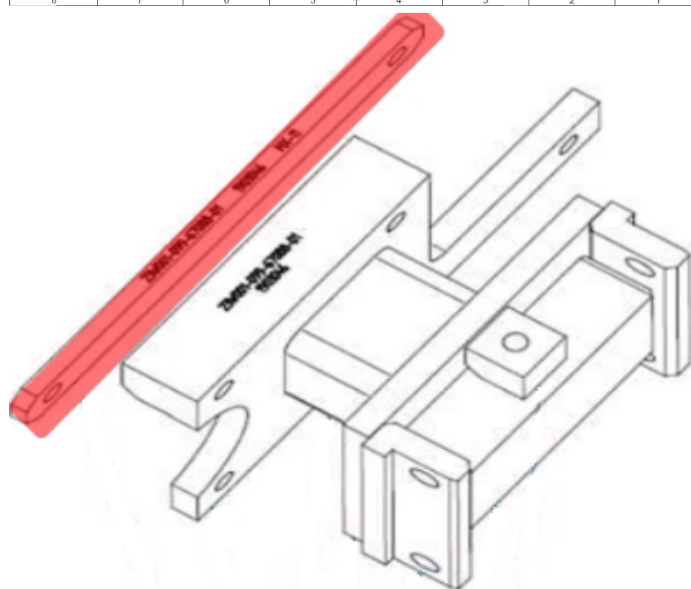

[NA valve spring disassembly tool 2154147PE](#) is available through PACCAR Parts and supersedes previous valve spring removal tools: 1809922PE, 2154145PE, 2154140PE, 1961372PE. This kit is compatible with all MX-11 and MX-13 engines EPA2013 and newer and is an improvement on the previous design by being more robust and safer to use.

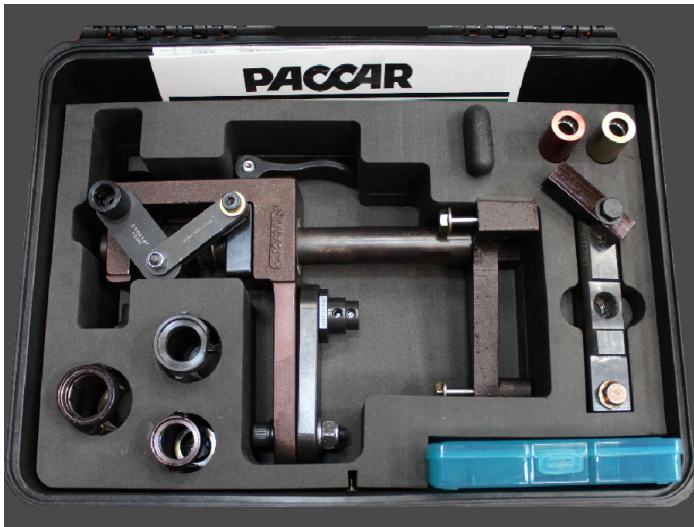

Procedure

1. Verify current inventory of tools listed above and order missing tools.