



# Volvo Chassis - Crankcase Ventilation ( CCV ) Oil Leaks - Technical Service Bulletin M-257 - 004, Technical Service Bulletin M-257 - 006 - US14 And US15 Emissions



> Internal Content

Should there be a report of this nature on a chassis built within the affected date range refer to [Technical Service Bulletin M-257 - 004](#) and [Technical Service Bulletin M-257 - 006](#) for more information.

 Tags [k58340423](#)

## Related links and attachments

[TSB 257-004 M](#)

[TSB 257-006 M](#)

 Live UI



## Feedback

[Give feedback](#)

to help improve the content of this article



## CCV Housing Inlet Tube, Replacement

M-257-004

August (2021)

### Valid for

Mack Trucks with an 11L engine built between 1/1/14 - 1/26/16

### Case description

Some trucks may experience oil leaks at the CCV housing inlet tube or at the split line between the upper and lower housings. The cause of this leak is the O-ring installed on the inlet tube. Follow the instruction in this document to properly fix this leak.



### Repair

To correct this issue, do not disassemble the CCV, replace the inlet tube. Clean the surrounding area to complete the repair. If it is determined that there is a leak at the housing other than the inlet O-ring, the complete CCV assembly will need to be replaced as this is a non-serviceable part. Do not attempt to tighten the split line screws on the housing or disassemble the assembly as seals and repair parts are no longer available for this component as they were on the older version of this component. If the collar on the CCV inlet is worn or broken at the locking lip, replace the complete CCV assembly. Additionally, Replace the CCV to cylinder block gasket any time the CCV assembly is removed.

### Parts

Part Number	Description	Quantity
22858729	Hose Assembly,	1

Copyright to this documentation belongs to the Volvo Group. No reproduction, copying, change, amendment or other similar disposal is entitled without prior written consent by the Volvo Group

The information contained herein is current at the time of its original distribution, but is subject to change. The reader is advised that printed copies are uncontrolled.

	CCV	
--	-----	--

## Procedure

---

You must read and understand the precautions and guidelines in Service Information, Function Group 20, Engine Safety Practices, before performing this procedure. If you are not properly trained and certified in this procedure, ask your supervisor for training before you perform it.

---

1. Secure the vehicle for service by parking it on a flat level surface, applying the parking brake, chocking the rear wheels, and placing the transmission in neutral or park.
2. Remove the quick connect fitting at the CCV.



3. Remove the formed rubber hose from the metal ventilation pipe coming from the valve cover.



4. Inspect the connection at the CCV for damage.
5. Connect the replacement hose to the CCV and position on metal ventilation pipe.
6. Tighten the clamp securing the rubber hose to the metal pipe to  $4 \pm 0.6$  Nm ( $35 \pm 5$  in-lb).

Note: If a leak still present and / or the ventilation pipe is cracked, replace the CCV.

Note: Replace the CCV to cylinder block gasket any time the CCV assembly is removed.

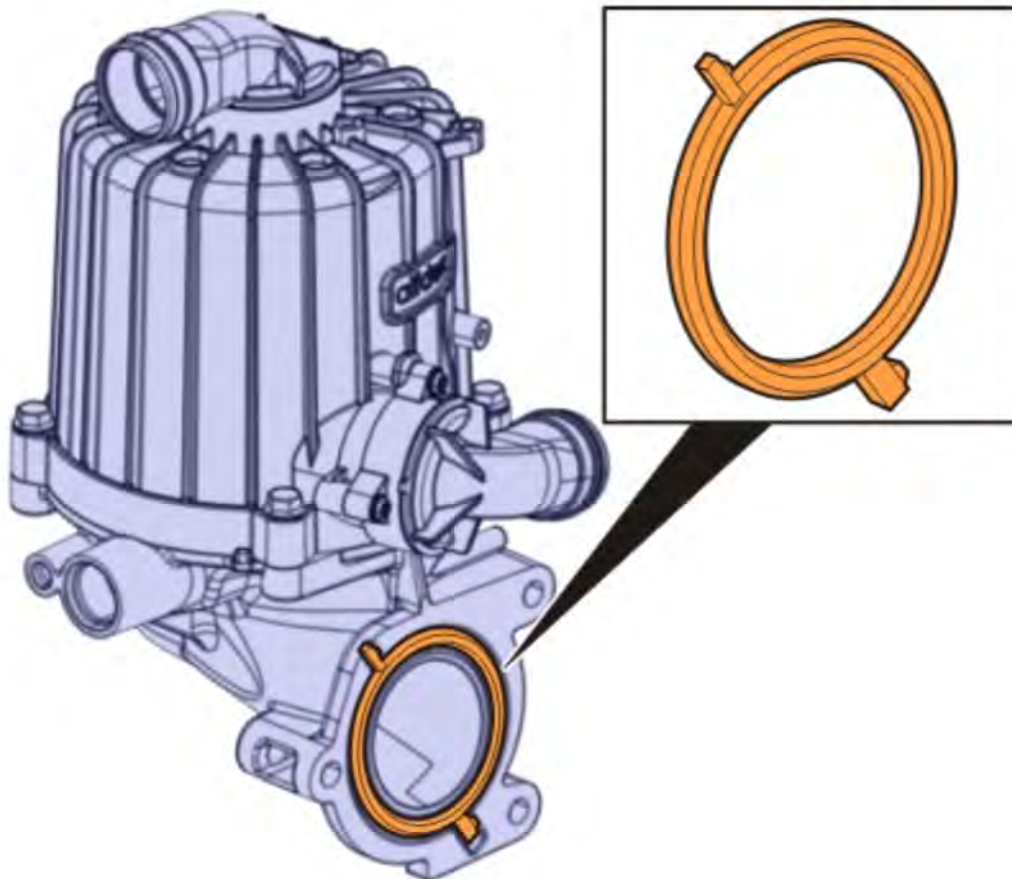



7. Remove the wheel chocks.

## Warranty information

### Reimbursement

This repair may be eligible for reimbursement if a product failure was experienced within time and mileage limits of the applicable Warranty coverage. Reimbursement is obtained via the normal claim handling process.	
Claim Type (used only when uploading from the Dealer Bus. Sys.)	W
Labor Code	
Primary Labor Code	2574-03-09-01 0.3 hrs.
Causal Part	21679517, 22011638

## Issued by

### Technical Service

Mack Trucks Inc. reserves the right to make any changes in design or to make additions to or upon its products without incurring any obligations to install the same on vehicles previously built.

# Crankcase Ventilation Separator Housing, Overhaul

M-257-006

August (2021)

## Valid for

Mack trucks with 11 Liter engines manufactured after 1/1/14.

## Case description

Some trucks may experience oil leaks at the CCV housing split line between the upper and lower housings. It has been determined that the O-rings installed on the rotor pack separator plate is the source of the leak.

## Parts

CCV Service Replacement Parts		
Description (Application)	Kit Part Number	Quantity
CCV Separator Kit	23077665	1
O-ring, Inlet Pipe 26.0 X 2.5	85148758	1
O-ring, Oil Supply Line 14.5 X 3.2	21541399	1

### All Applications

CCV Separator Kit	Quantity
131 x 3 mm O-rings for upper and lower rotor pack separator plate	2
33 x 3.5 mm O-ring for the outlet inner seal	1
30 x 2.5 mm O-ring for outlet outer seal	1
Screws for attaching separator housing to the base	4
CCV to cylinder block mounting gasket	1

## Repair

If a leak is found, replace all O-rings and clean the surrounding area to complete the repair. If the turbine is not free spinning and/or has bearing noise, replace the complete assembly. The oil jet should be inspected and cleaned of any debris. If the collar on the CCV inlet is worn or broken at the locking lip, replace the complete CCV assembly.

Additionally, Replace the CCV to cylinder block gasket any time the CCV assembly is removed.

## Procedure

---

You must read and understand the precautions and guidelines in Service Information, Function Group 20, Engine Safety Practices, before performing this procedure. If you are not properly trained and certified in this procedure, ask your supervisor for training before you perform it.

---

1. Remove the CCV assembly according to Impact instructions.
2. Inspect the inlet quick connect nipple for any signs of damage or wear that would contribute to any leaks in this area. If any damage is noted, replace the complete CCV assembly.

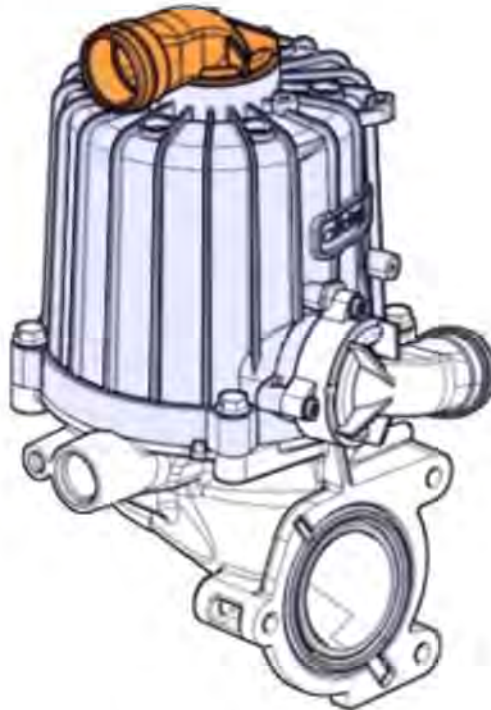

3. Replace the O-ring in the inlet quick coupler hose with a new one.
4. Reach into the flange opening and try spinning the turbine to see if it is free with no hard spots or bearing noise. It should spin freely. If not, replace the complete assembly.



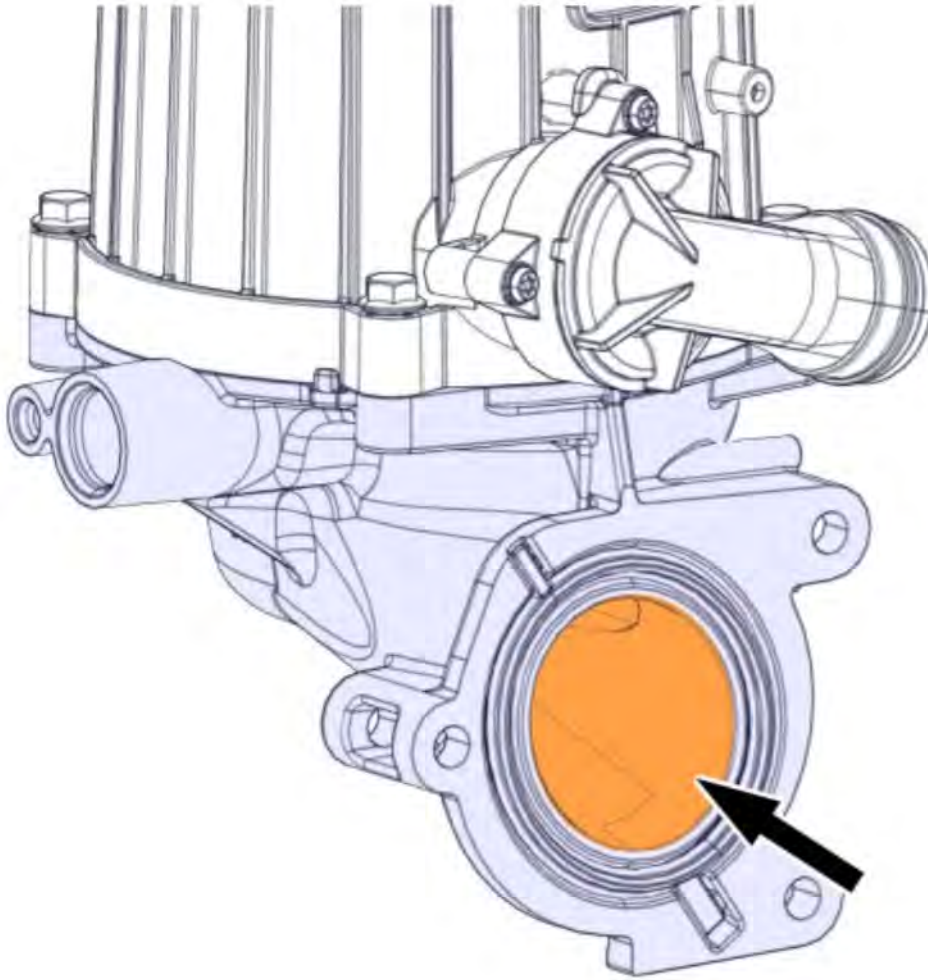

5. Remove the four screws and separate the lower housing from the separator housing.

Note: Discard the screws

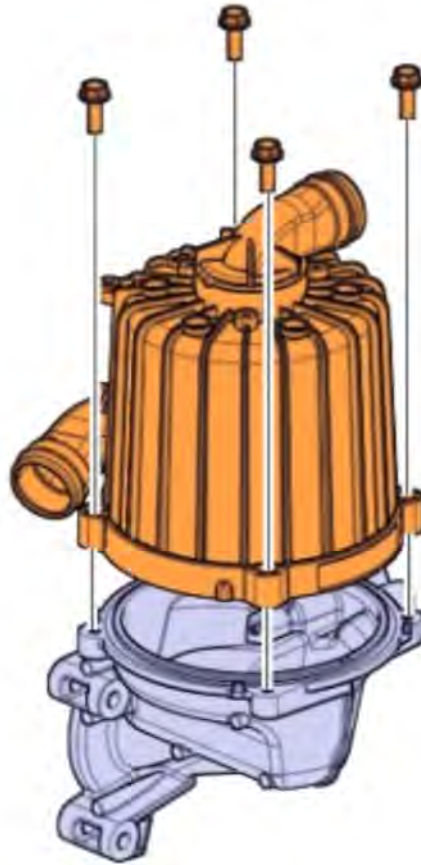

6. Inspect the oil jet for being loose in the lower housing and for any signs of debris or foreign objects that could restrict oil flow. Do not press on the oil jet.

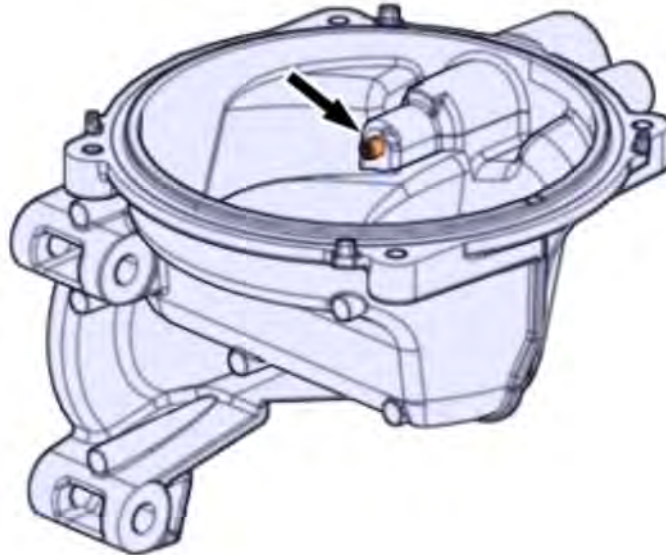

7. Remove the two screws and remove the valve/outlet nipple from the separator housing.

Note: Discard the O-rings.

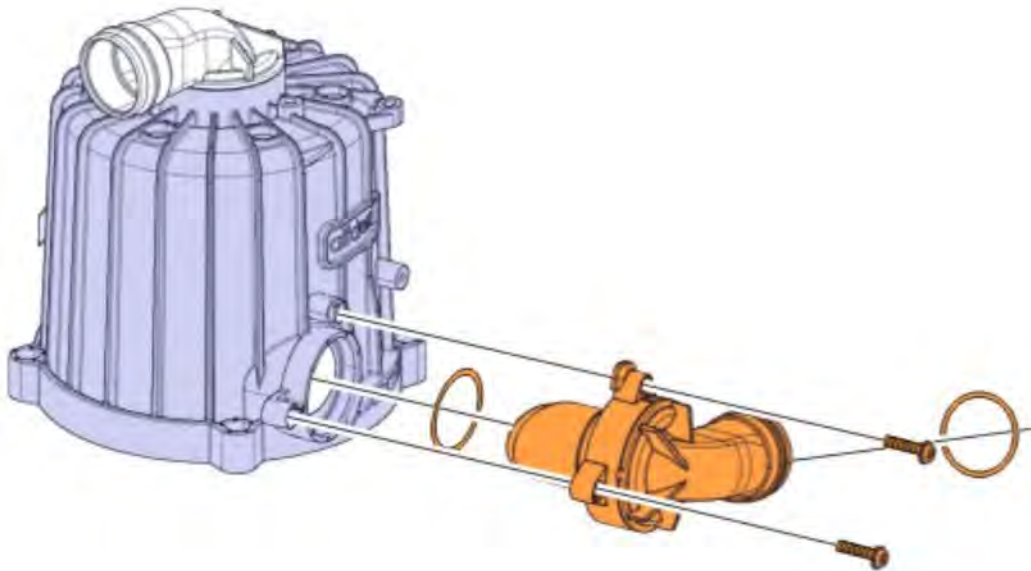

8. Use a small, stiff rod or similar tool [A small allen key used here] in the housing slot to gently pop out the rotor pack from the separator housing.

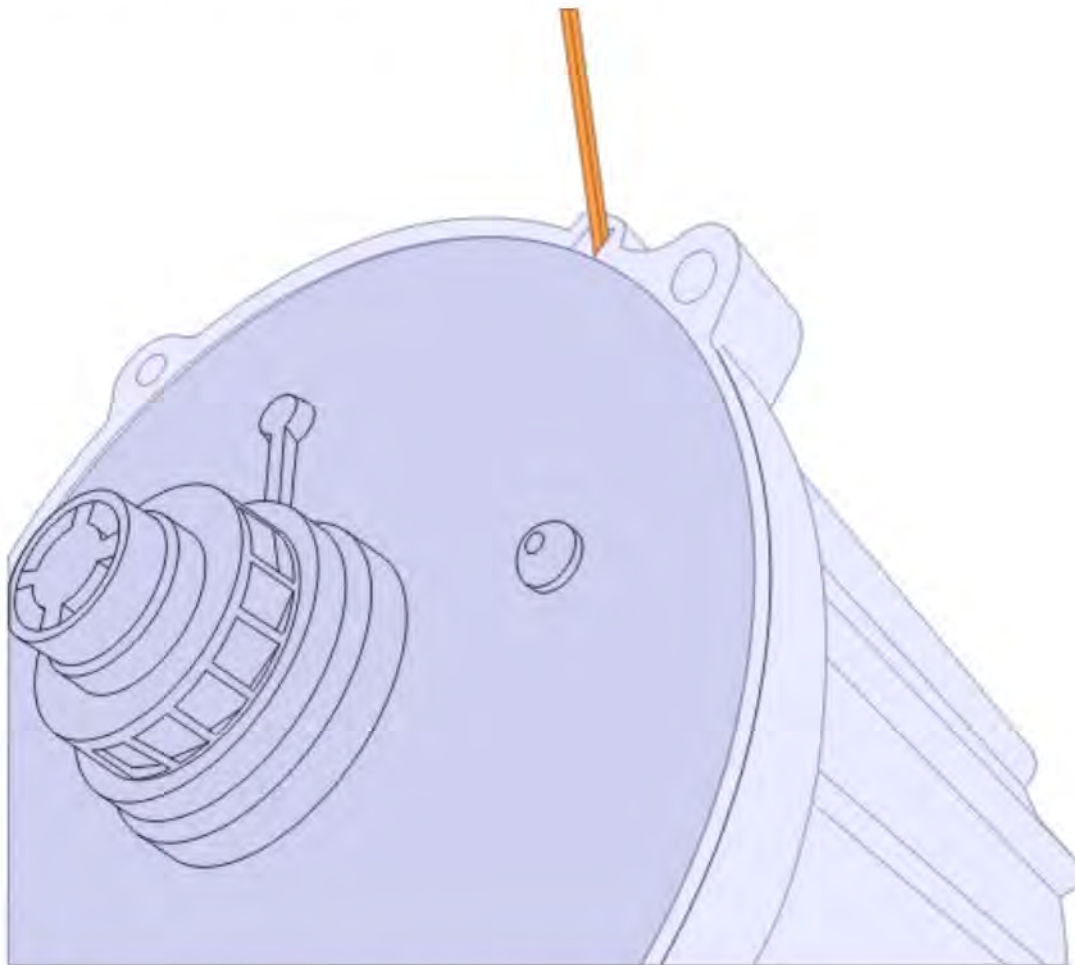

**Note:** Be careful to not damage the rotor assembly.



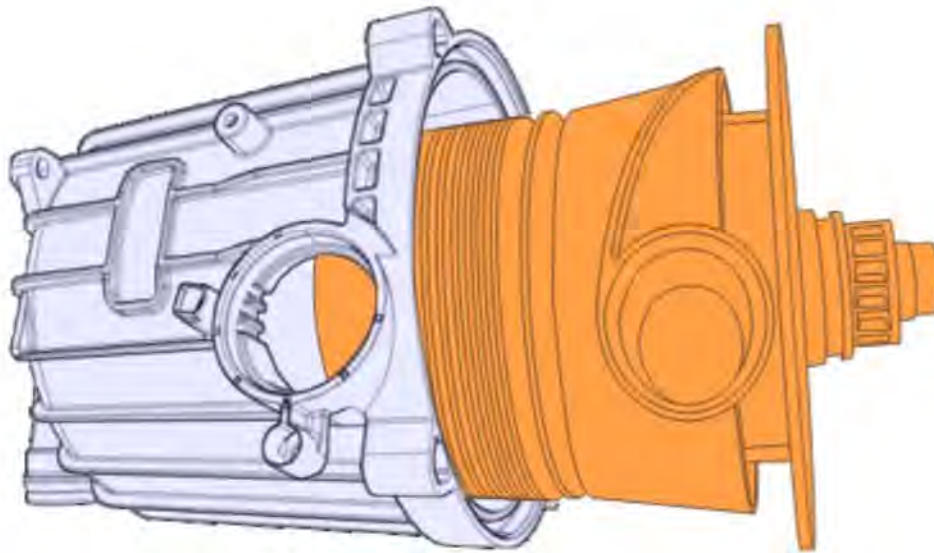

9. Inspect the upper bearing for smooth operation. If the bearing is not smooth, replace the complete assembly.
10. Clean off all the parts with a soft cloth in preparation for assembly. Do not use chemicals on the rotor unit.
11. Install a new O-Ring in the separator housing. Note the cut-away in the inner housing flange. This aligns the rotor pack to the housing.
12. Carefully align and install the rotor pack evenly into the separator housing making sure there is no binding in the upper bearing on assembly. Push in the lower plate starting at the opposite side of the housing slot and work the plate towards the slot. It should pop when completely installed. Test the impeller to make sure it spins freely.

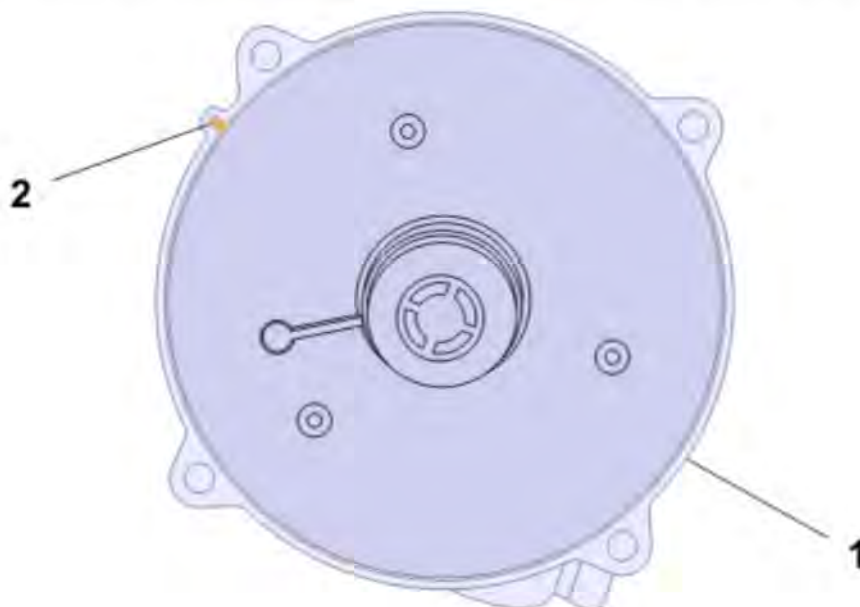

1. Start here
2. Housing slot

13. Install two O-rings on the valve/outlet nipple, carefully install the nipple into the separator housing and tighten the two retaining screws to 3.2 +/- 0.5 Nm.



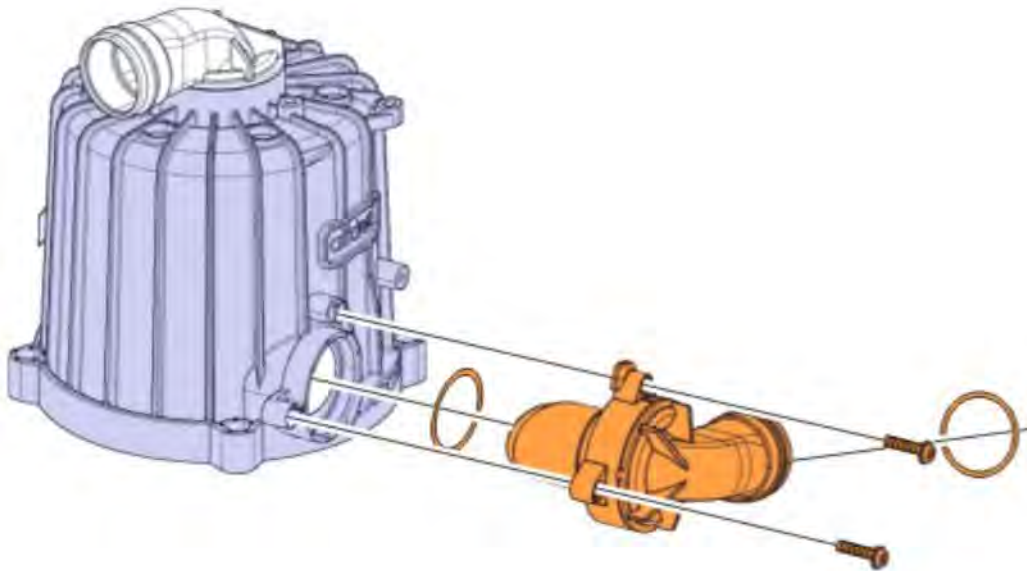

14. Install the second O-ring in the lower housing, align and install the separator housing the lower housing taking care to align it correctly.
15. Install the four new separator housing screws and torque them to 12 +/- 2 Nm.

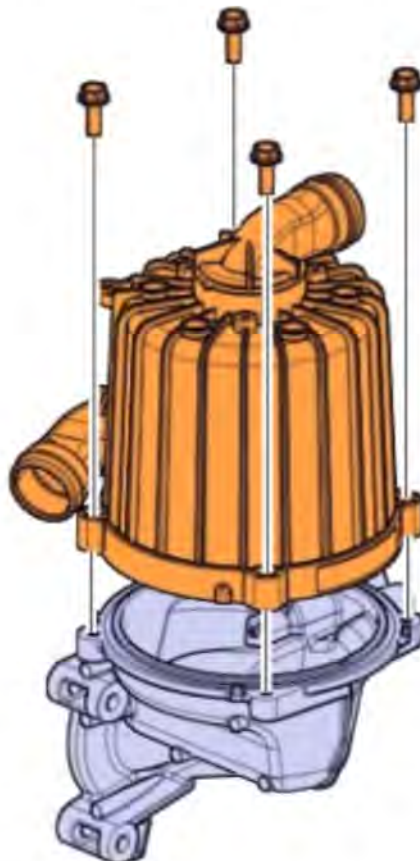

16. Replace the O-ring on the oil supply hose.
17. Install the new mounting gasket and install the CCV assembly according to Impact instructions.
18. Run up the engine to do a final check for leaks at the housing split line.

## Warranty information

### Reimbursement

This repair may be eligible for reimbursement if a product failure was experienced within time and mileage limits of the applicable Warranty coverage. Reimbursement is obtained via the normal claim handling process.	
Claim Type (used only when uploading from the Dealer Bus. Sys.)	W
Labor Code	
Primary Labor Code	2574-04-09-01 0.3 hrs.
Secondary Labor Code	2571-03-02-03 0.6 hrs
Causal Part	21679517

## Issued by

### Technical Service

Mack Trucks North America reserves the right to make any changes in design or to make additions to or upon its products without incurring any obligations to install the same on vehicles previously built.