

**WMG6 - Retrofitting Control Unit for Acoustic Simulator (Workshop Campaign)**

Important: **CRITICAL WARNING** -This campaign includes steps where control unit(s) in the vehicle will be programmed with the PIWIS Tester. The vehicle voltage must be maintained between 13.5 volts and 14.5 volts during this programming. Failure to maintain this voltage could result in damaged control unit(s). Damage caused by inadequate voltage during programming is not a warrantable defect. The technician must verify the actual vehicle voltage in the PIWIS Tester before starting the campaign and also document the actual voltage on the repair order.

Model Year: **2021**

Model Line: **Taycan (Y1A/Y1B)**

Concerns: **Control unit for acoustic simulator (i-Sound)**

Information: **Due to worldwide semiconductor shortages experienced by some suppliers, the affected vehicles were built without an acoustic simulator control unit.**  
As a result, sound enrichment in the passenger compartment is not available on these vehicles.

Action required: Retrofit control unit for acoustic simulator.

Affected Vehicles: Only vehicles assigned to the campaign (see also PCSS Vehicle Information).

Installation  
Position:

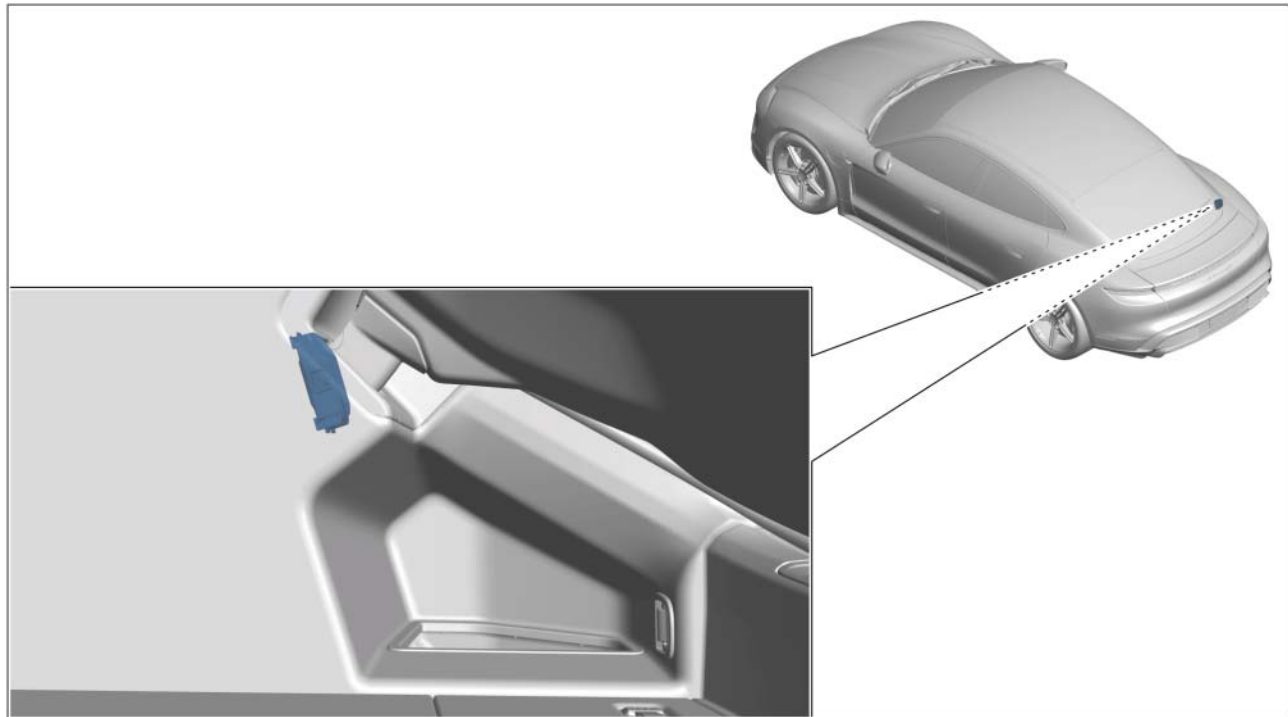

*Installation position of control unit for acoustic simulator (i-Sound)*

## Parts required

Parts Info:	Part No.	Designation	Number
	V04015001GM	⇒ i-Sound amplifier - Location	1 ea.
	N 10459202	⇒ Cheese head bolt - i-Sound amplifier	2 ea.
	N 98926102	⇒ Cheese head bolt - Seat belt mount to body, rear right	1 ea.

## Required tools

- Tool:
- Battery charger with a current rating of **at least 90 A** and - if required - **also with a current and voltage controlled charge map** for lithium starter batteries, e.g. **VAS 5908 90 A battery charger**
  - **9900 - PIWIS Tester 3**
  - Torque wrench, 2-10 Nm (1.5-7.4 ftlb.), e.g. **VAG 1783 torque wrench, 2-10 Nm (1.5-7.4 ftlb.)**
  - Torque wrench, 6-50 Nm (4.5-37 ftlb.) e.g. **V.A.G 1331A - torque wrench, 6-50 Nm (4.5-37 ftlb.)**

## Retrofitting Control unit for acoustic simulator



### Information

The affected acoustic simulator control unit for interior sound is located at the rear **right**. The acoustic simulator control unit for the exterior sound is located at the rear left and is **not relevant** for this campaign.

Please note therefore that the relevant components on the **right**-hand side of the vehicle must be removed in order to access the installation position of the affected control unit.

- Work Procedure: 1 Retrofit control unit for acoustic simulator for interior sound.  
 Also see ⇒ *Workshop Manual '260519 Removing and installing control unit for acoustic simulator'*
- 2 Teach control unit for acoustic simulator for interior sound.

### NOTICE

#### Voltage drop

- Risk of irreparable damage to control unit
  - Risk of damage to control unit
  - Fault entries in the control unit
  - Coding in the control unit is aborted
  - Malfunctions in control unit, even during programming
- ⇒ Before disconnecting the control unit, switch off ignition and remove ignition key.
- ⇒ Make sure that the power supply is not interrupted during programming.
- ⇒ Connect battery charger/power supply - Suitable for AGM Type batteries, recommended current rating of 90A fixed voltage 13.5V to 14.5V.



### Information

#### Ensure the consistency of a combination of hardware and software versions

After performing software updates, always make sure that the target software versions are also actually installed on the control units and that the system is therefore ensured.

This also applies in the case of hardware replacement.

See TI 9X00 Information on the software system for various control units in the vehicle (112/21)

**Information**

The **9900 - PIWIS Tester III** instructions take precedence since the description may be different with later Tester releases.

The procedure described here has been structured in general terms; different text or additions may appear on the **9900 - PIWIS Tester III**.

- 2.1 Connect a suitable battery charger, e.g. **Battery charger 90A**, to the jump-start terminals in the luggage compartment and switch it on.
- 2.2 Place original remote control in emergency start tray.
- 2.3 Connect the Tester to the vehicle and start it. Establish operational readiness on the vehicle.
- 2.4 Select the vehicle type if necessary.
- 2.5 In the **overview**, select the **interior acoustics control unit (i-Sound)**. Press •F12" to continue.
- 2.6 Select **Coding/programming**.
- 2.7 **Automatic programming** must now be selected. Press •F12" to continue.  
Once programming is completed successfully, the corresponding message is displayed on the PIWIS Tester.



*Emergency start tray*

- 3 Reading out and erasing fault memories.

**Information**

If there are faults in the control units, these must first be **localized** and **corrected**. This work **cannot** be invoiced under the workshop campaign number.

- 4 Disconnect the PIWIS Tester from the vehicle.
- 5 End operational readiness (switch off ignition).
- 6 Switch off and disconnect the battery charger.
- 7 Enter the campaign in the Guarantee and Maintenance booklet.

**Warranty processing**



**Information**

The specified working times were determined specifically for carrying out this campaign and include all required preliminary and subsequent work.

The working times may differ from the working times published in the Labor Operation List in PCSS.

Scope 1:

<b>Working time:</b>		
Retrofitting Control unit for acoustic simulator		Labor time: <b>170 TU</b>
Includes:	Connecting and disconnecting battery charger	
	Connecting and disconnecting PIWIS Tester	
	Teaching control unit for acoustic simulator for interior sound	
	Reading out and erasing fault memories	
<b>Required parts:</b>		
V04015001GM	i-Sound amplifier	1 ea.
N 10459202	Cheese head bolt	2 ea.
N 98926102	Cheese head bolt	1 ea.
⇒ <b>Damage code WKL6 066 000 1</b>		

**Important Notice:** Technical Bulletins issued by Porsche Cars North America, Inc. are intended only for use by professional automotive technicians who have attended Porsche service training courses. They are written to inform those technicians of conditions that may occur on some Porsche vehicles, or to provide information that could assist in the proper servicing of a vehicle. Porsche special tools may be necessary in order to perform certain operations identified in these bulletins. Use of tools and procedures other than those Porsche recommends in these bulletins may be detrimental to the safe operation of your vehicle, and may endanger the people working on it. Properly trained Porsche technicians have the equipment, tools, safety instructions, and know-how to do the job properly and safely. Part numbers listed in these bulletins are for reference only. The work procedures updated electronically in the Porsche PIWIS diagnostic and testing device take precedence and, in the event of a discrepancy, the work procedures in the PIWIS Tester are the ones that must be followed.

© 2022 Porsche Cars North America, Inc.