



Subject: INFOTAINMENT DOOR SPEAKER RATTLE NOISE	Service Alert No.: SA-025/22
	Last Issued : 04/27/2022

BULLETIN NOTES

APPLICABLE MODEL(S)/VINS

2019-2022 Mazda3

DESCRIPTION

Some customers may experience infotainment door rattle noise. Follow the repair procedure to help determine the cause.

REPAIR PROCEDURE

1. Verify the customer concern.
2. Document the following:
 - Infotainment Source
 - Radio, Bluetooth, Apple Carplay / Android Auto.....etc.
 - If song is playing,
 - Artist?
 - Name of song?
 - Infotainment volume level?
 - If volume is lowered, does rattle noise disappear?
 - Infotainment bass level?
 - If bass is lowered, does rattle noise disappear?
 - Vehicle parked or driving?
 - If driving, document vehicle speed, street or highway, concrete or asphalt?
 - If possible, record a video of the rattle noise.
3. Check applicable door speaker bolts for looseness:

	Front Door Speaker	Rear Door Speaker
--	---------------------------	--------------------------

CONSUMER NOTICE: The information and instructions in this bulletin are intended for use by skilled technicians. Mazda technicians utilize the proper tools/ equipment and take training to correctly and safely maintain Mazda vehicles. These instructions should not be performed by "do-it-yourselfers." Customers should not assume this bulletin applies to their vehicle or that their vehicle will develop the described concern. To determine if the information applies, customers should contact their nearest authorized Mazda dealership. Mazda North American Operations reserves the right to alter the specifications and contents of this bulletin without obligation or advance notice. All rights reserved. No part of this bulletin may be reproduced in any form or by any means, electronic or mechanical---including photocopying and recording and the use of any kind of information storage and retrieval system ---without permission in writing.

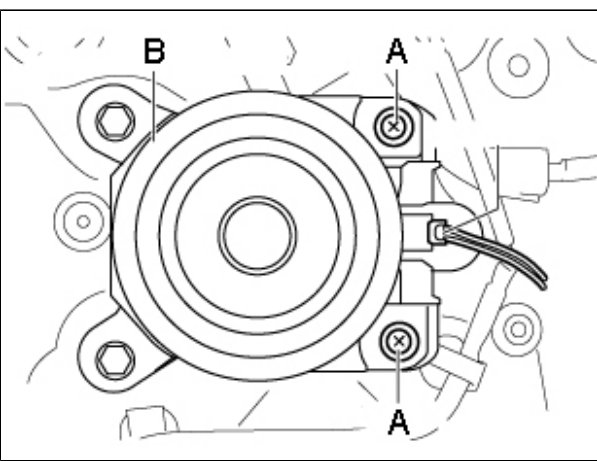
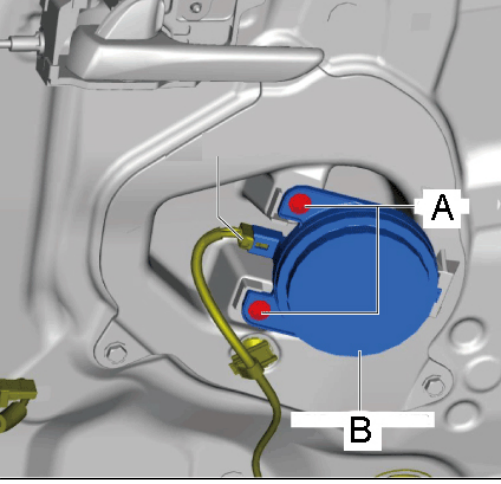
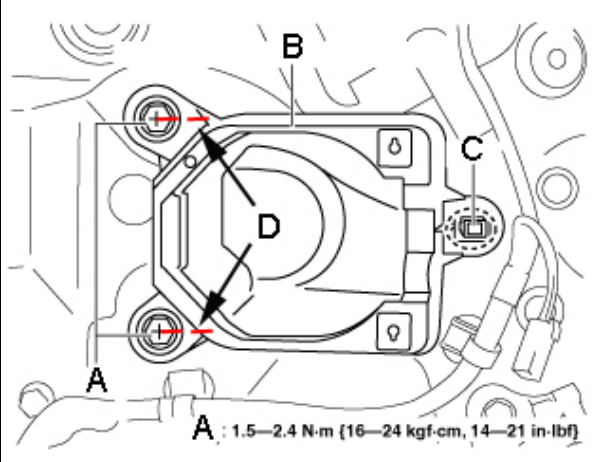
<p>a. Check the speaker bolts (A) for looseness by hand (DO NOT use tools). Document if bolts are loose by hand.</p>	 <p>A: Bolts B: Speaker</p>	 <p>A: Bolts B: Speaker</p>
<p>b. Apply paint mark to front door speaker bracket bolts (A) and bracket (B). c. Set torque wrench to 14 in- lbs. d. Turn torque wrench clockwise and document if clicker engages or bolt moves.</p> <ul style="list-style-type: none"> • If the clicker engages and bolt does not move, the bolt torque is good. • If the bolt paint mark moves clockwise, the bolt is loose. 	 <p>A: Bolts B: Speaker bracket C: Connector D: Paint Mark (red marks are shown as an example)</p>	<p>---</p>

4. Contact Hotline and provide results.

CONSUMER NOTICE: The information and instructions in this bulletin are intended for use by skilled technicians. Mazda technicians utilize the proper tools/ equipment and take training to correctly and safely maintain Mazda vehicles. These instructions should not be performed by "do-it-yourselfers." Customers should not assume this bulletin applies to their vehicle or that their vehicle will develop the described concern. To determine if the information applies, customers should contact their nearest authorized Mazda dealership. Mazda North American Operations reserves the right to alter the specifications and contents of this bulletin without obligation or advance notice. All rights reserved. No part of this bulletin may be reproduced in any form or by any means, electronic or mechanical--including photocopying and recording and the use of any kind of information storage and retrieval system ---without permission in writing.