

March 1, 2022

Version 2

MIL Comes On with DTC P2422

Supersedes 20-056, dated August 5, 2020, to revise the information highlighted in yellow.

AFFECTED VEHICLES

Year	Model	Trim Level	VIN Range
2016–20	Pilot	ALL	ALL

REVISION SUMMARY

- Under AFFECTED VEHICLES, the year was updated.
- Under PARTS INFORMATION – REPAIR PROCEDURE A and B, the part number for the Canister Set (2020) was added.
- Under WARRANTY CLAIM INFORMATION, the failed part number was updated.

SYMPTOM

The MIL comes on with DTC P2422 (EVAP canister vent shut valve stuck closed malfunction).

PROBABLE CAUSE

Dirt may be clogging the EVAP canister vent tube.

CORRECTIVE ACTION

Inspect the canister vent tube. If necessary, replace the canister assembly and install a canister drain kit. This includes a canister filter box.

PARTS INFORMATION – REPAIR PROCEDURE A

Part Name	Part Number	Quantity
Canister Drain Kit	06171-TG7-305	1
Canister Set (2016–2019)	17011-TZ5-A01	1
Canister Set (2020)	17011-TG7-A11	1
Retainer	17711-SNA-A01	1

CUSTOMER INFORMATION: The information in this bulletin is intended for use only by skilled technicians who have the proper tools, equipment, and training to correctly and safely maintain your vehicle. These procedures should not be attempted by “do-it-yourselfers,” and you should not assume this bulletin applies to your vehicle, or that your vehicle has the condition described. To determine whether this information applies, contact an authorized Honda automobile dealer.

PARTS INFORMATION – REPAIR PROCEDURE B

Part Name	Part Number	Quantity
Canister Drain Kit	06171-TG7-305	1
Canister Set (2016–2019)	17011-TZ5-A01	1
Canister Set (2020)	17011-TG7-A11	1
Retainer	17711-SNA-A01	1
Pre Chamber Gasket (Exhaust)	18393-SDB-A00	1
Self-Lock Nut	90212-SA5-003	3
Rear Differential Bracket Flange Bolt (10 x 25 mm)	90167-SAA-010	4
Rear Differential Mount Flange Bolt (14 x 85 mm)	90160-TZ6-A00	2
Propeller Shaft 12-point Bolt (8 x 21 mm)	90113-S10-000	4

NOTE: A canister filter box is included in the canister drain kit. Order a replacement canister filter box only when you need to replace it.

PARTS INFORMATION – REPAIR PROCEDURE C

Part Name	Part Number	Quantity
Replacement Canister Filter Box	17315-TM8-L01	1

WARRANTY CLAIM INFORMATION

The normal warranty applies.

Operation Number	Description	Flat Rate Time	Defect Code	Symptom Code	Template ID	Failed Part Number
1201Q6	Repair Procedure A - 2WD vehicles only. Inspect and replace the canister assembly, and install a canister drain kit (includes canister filter box).	1.0 hr	03214	03217	A20056A	17011-TG7-A11
1201Q7	Repair Procedure B - AWD vehicles only. Inspect and replace the canister assembly, and install a canister drain kit (includes canister filter box).	1.6 hr	03214	03217	A20056B	17011-TG7-A11
1205A5	Repair Procedure C - Inspect and replace the canister filter box.	0.3 hr	03214	03217	A20056C	17011-TG7-A11

Skill Level: Repair Technician

INSPECTION

Without Canister Filter Box

1. Disconnect the drain tube from the EVAP canister.

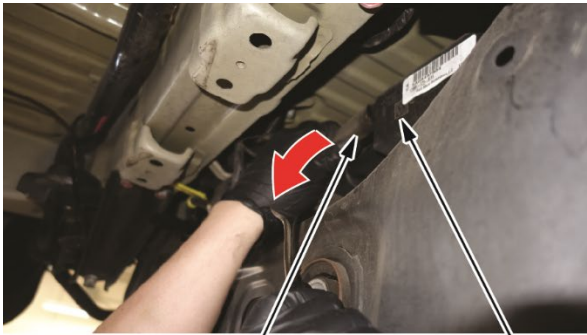

Disconnect the drain tube.

EVAP CANISTER



Inspect for dirt or dust.

2. Check if there is any dust or dirt in the tube by visually inspecting and tapping/shaking it.
 - *2WD models:* If the drain tube has any dust or dirt inside it, go to REPAIR PROCEDURE A.
 - *AWD models:* If the drain tube has any dust or dirt inside it, go to REPAIR PROCEDURE B.
 - If there is no dust or dirt inside the drain tube, this bulletin does not apply. Continue with normal system troubleshooting.

With Canister Filter Box

1. Disconnect drain tube C from the canister filter box.

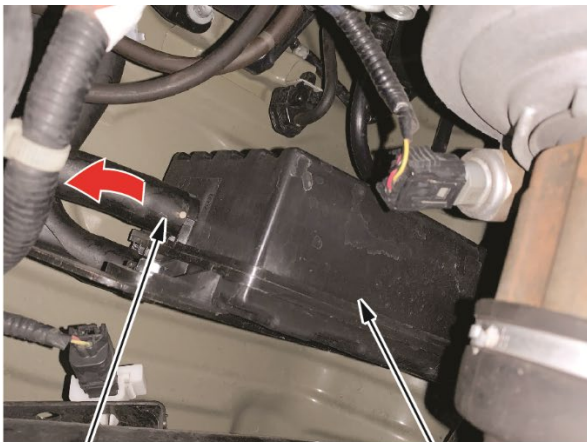

Disconnect the drain tube.

CANISTER FILTER BOX



Inspect for dirt or dust.

2. Check if there is any dust or dirt in the tube by visually inspecting and tapping/shaking it.
 - *All models:* If there is dust or dirt inside the drain tube, go to REPAIR PROCEDURE C.
 - If there is no dust or dirt inside the drain tube, this bulletin does not apply. Continue with normal system troubleshooting.

REPAIR PROCEDURE A

1. Using the appropriate tools in the vehicle, lower the spare tire all the way to the ground, and remove it from the hoist cable.

NOTE: **Do not** use power tools.

2. Disconnect the quick-connect fitting, hoses, and connectors from the EVAP canister.

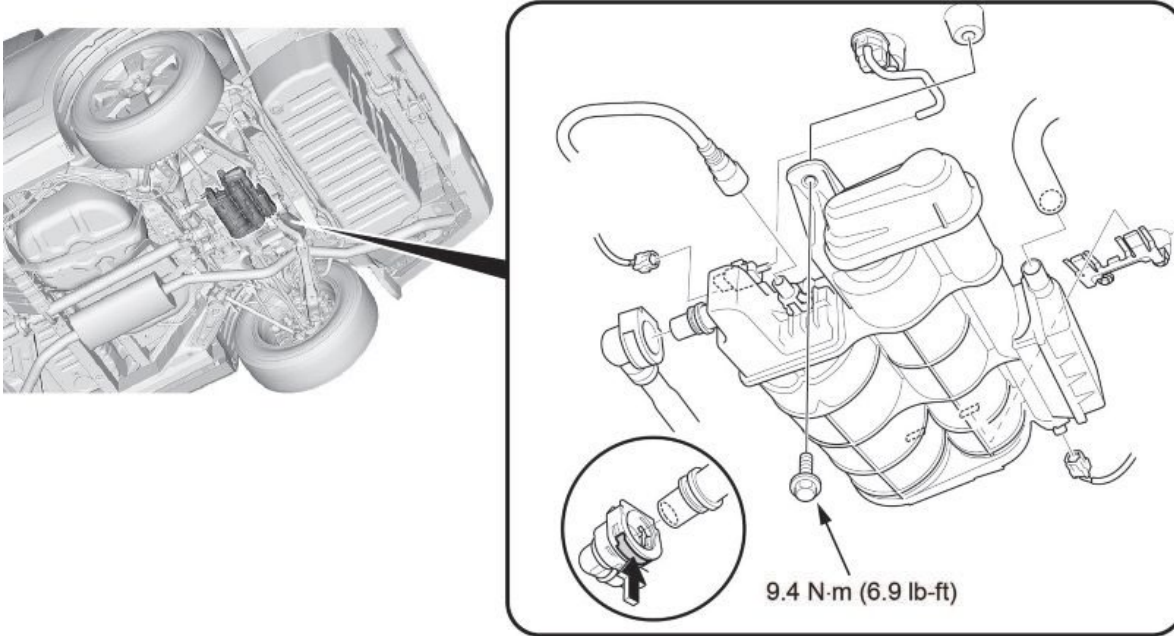

3. Remove and reuse the EVAP canister bolt on the driver's side, then slide the canister toward the driver's side to remove it from the vehicle.
4. Remove the crossmember center brace and flange bolts. Do not reuse them. Replacement parts and hardware are included in the canister drain kit.

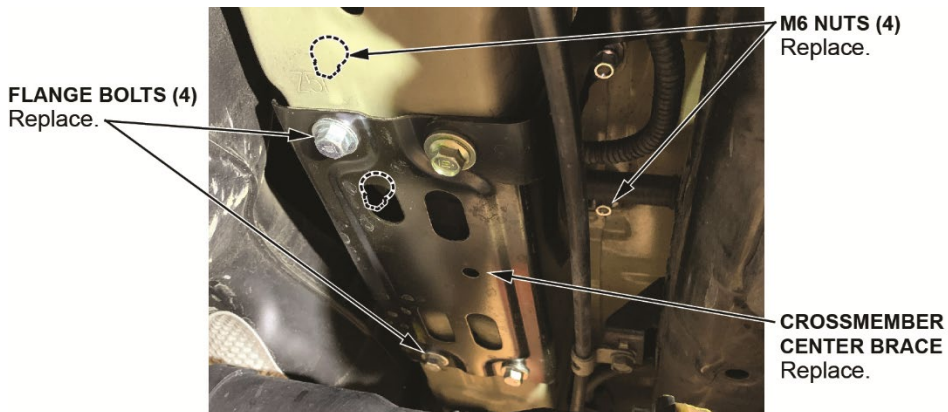

5. Remove the rear left subframe stay and flange bolts. Do not reuse them. Replacement parts and hardware are included in the canister drain kit.

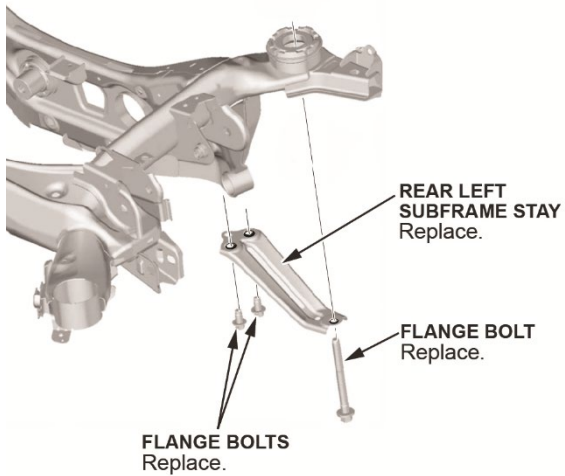

6. Remove the drain tube and drain tube joint connected to the frame rail. Do not reuse the drain tube or drain tube joint.

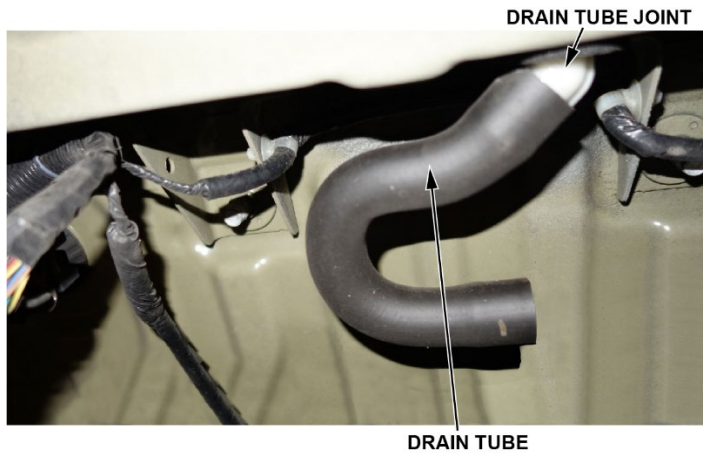

7. Disconnect the rear subframe harness from the crossmember.



REAR SUBFRAME HARNESS
Disconnect.

8. Clean the surrounding area with isopropyl alcohol and cover the hole with the 30 mm door hole seal (P/N 91619-SE0-000) included in the canister drain kit.

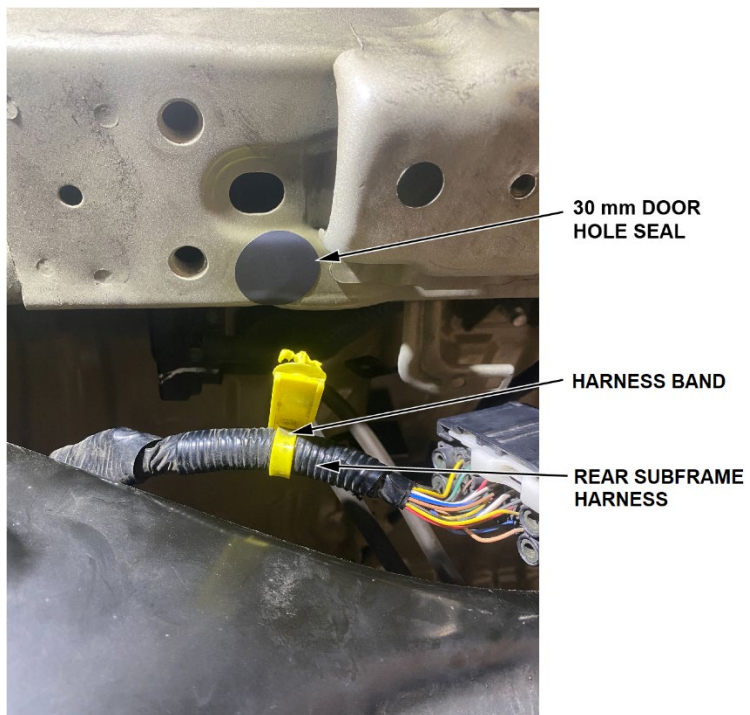

9. Cut the yellow harness band off the rear subframe harness. Make sure you do not damage the harness.

10. Loosely install the new crossmember center brace (P/N 75647-TZ5-A01) and canister filter bracket A (P/N 17316-TG7-A30) as shown. Make sure canister filter bracket A is between the 8 x 22 mm bolt (P/N 90162-S09-000) and the crossmember center brace. Use the 8 x 23.5 mm bolts (P/N 90101-SE3-003) and paint cutting M6 nuts (P/N 90361-TZ5-A00) included in the canister drain kit.

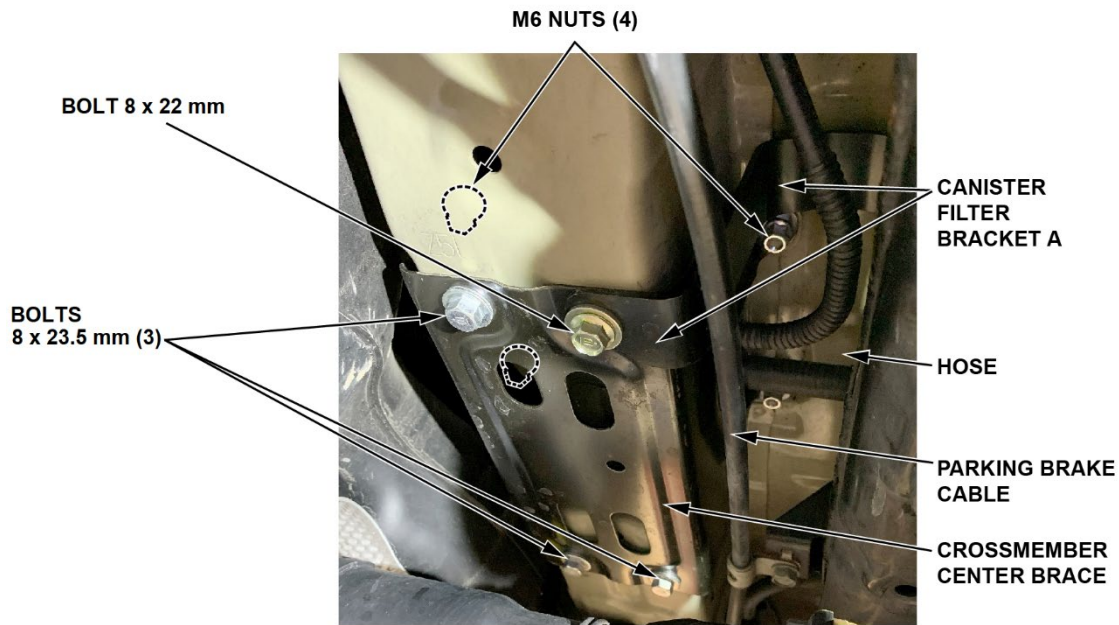

NOTE:

- Tighten the hardware by hand. You will torque them to specification in a later step.
- Make sure canister filter bracket A is routed above the hoses.
- Attach canister bracket A as shown.

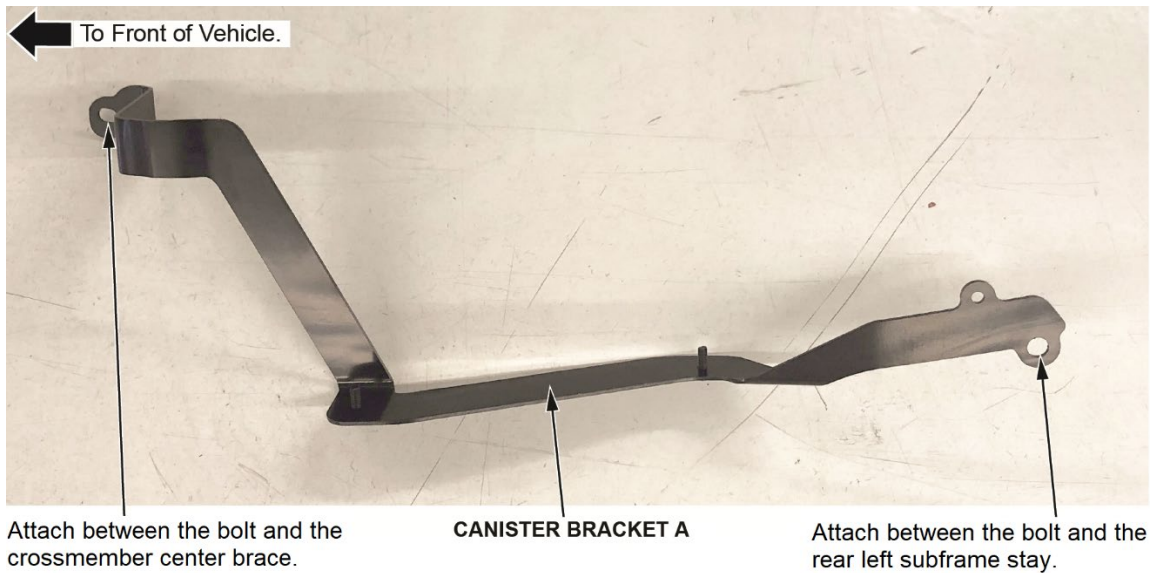

11. Loosely install the new rear left subframe stay (P/N 50378-TG7-A02). Make sure canister filter bracket A is between the flange bolt (P/N 90161-SHK-A00) and rear left subframe stay as shown.

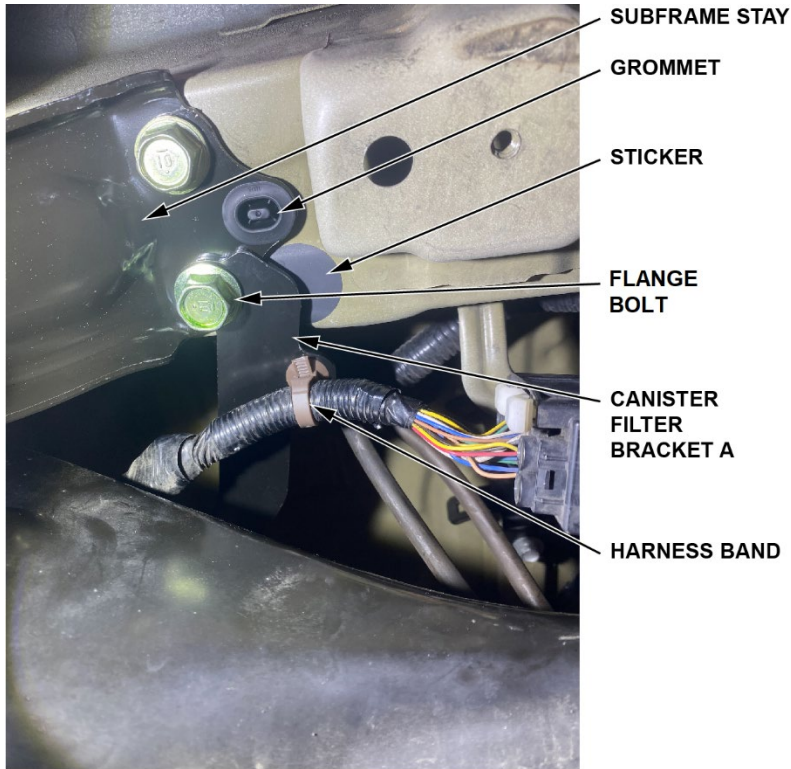

12. Install a new harness band (P/N 91507-SNA-003) included in the canister drain kit, and attach it to the rear left subframe stay as shown.
13. Install a new grommet (P/N 91603-TG7-A02) included in the canister drain kit as shown.
14. Tighten the new flange bolts to the specified torque:
- Torque the 14 x 144 mm bolt (P/N 90161-S3N-000) to **132 N·m (97 lb-ft)**.
 - Torque the 12 x 30 mm bolts (P/N 90161-SHJ-A00) to **64 N·m (47 lb-ft)**.

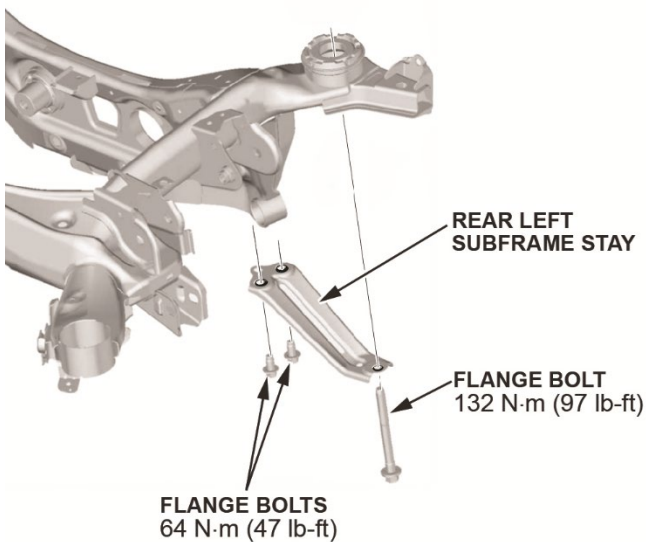

15. Torque the crossmember center brace bolts to **19-25 N•m (14-18.4 lb-ft)**, and torque the nuts to **6.9-12 N•m (5.1-8.9 lb-ft)**.

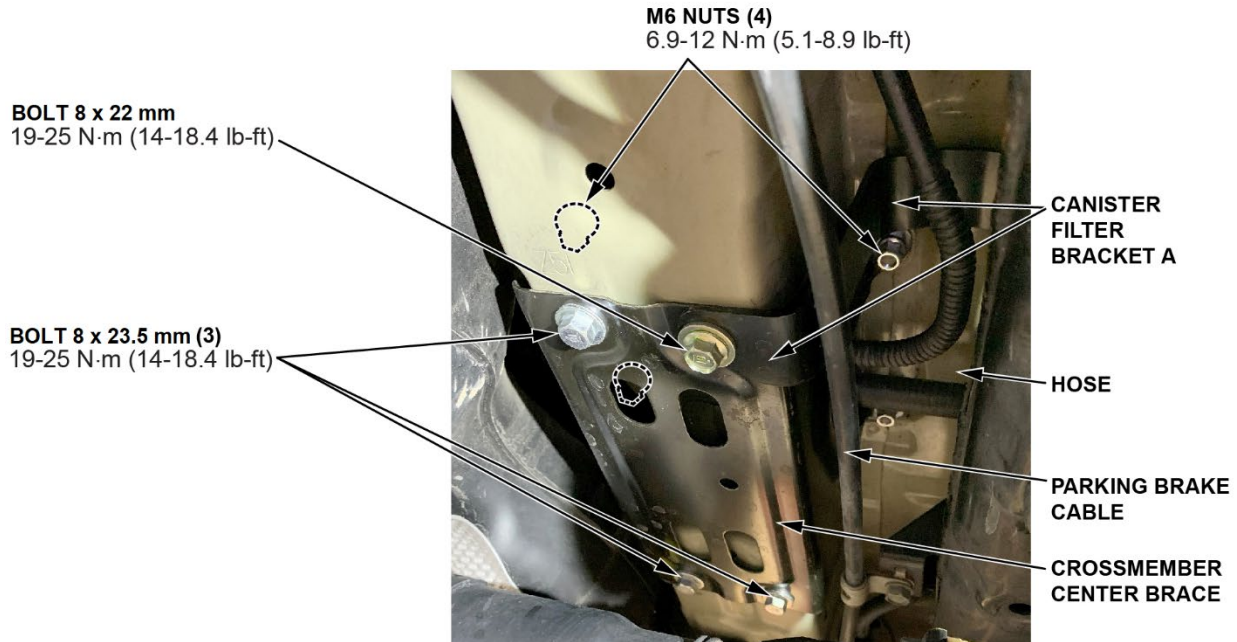

16. Unclip the rear subframe subharness, and install the spring nut (P/N 74103-TZ5-A01) included in the canister drain kit.

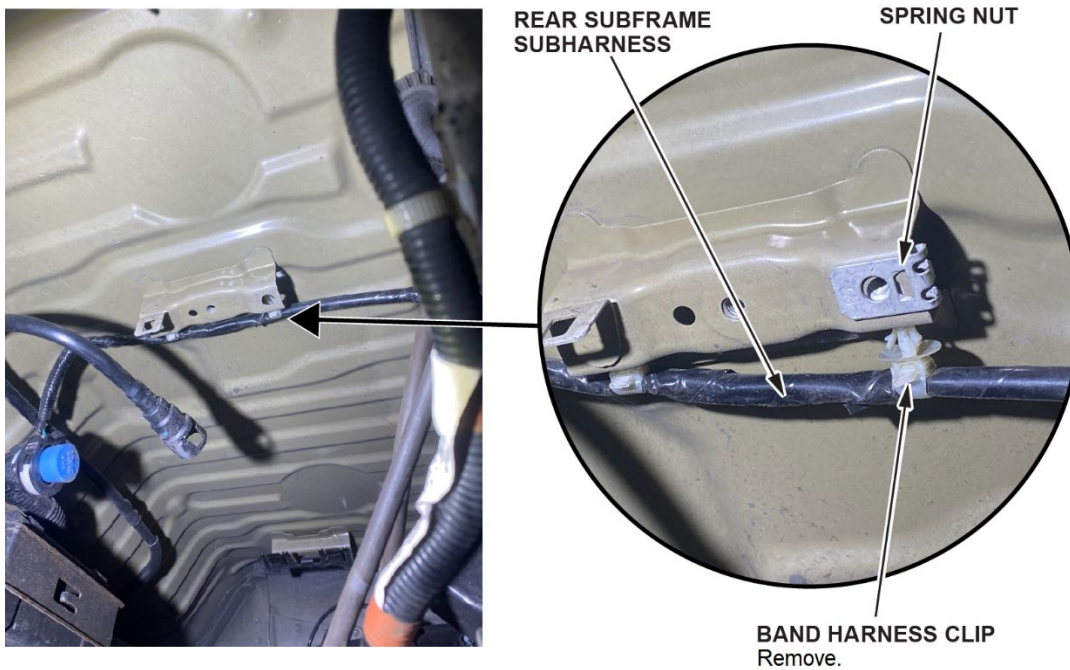

17. Cut the subharness band clip off the harness. Make sure you do not damage the harness.

18. Loosely install the new subharness band clip on the subharness as shown.



SUBHARNESS BAND CLIP

SUBHARNESS

19. Loosely install canister filter bracket B (P/N 17317-TG7-A30) using the 6 mm bolt (P/N 93405-0602004) included in the kit, and attach the subharness band clip as shown.

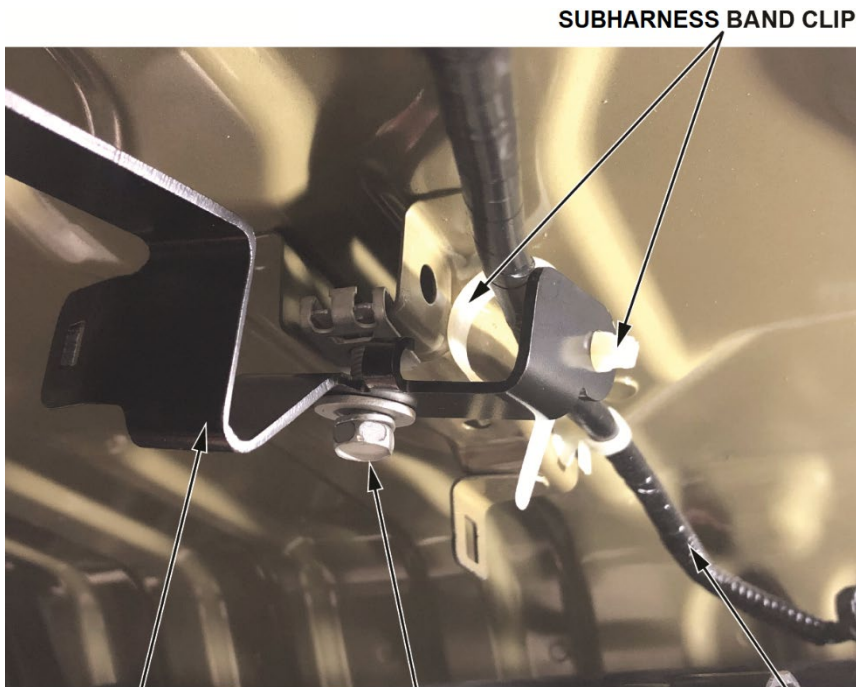

SUBHARNESS BAND CLIP

CANISTER BRACKET B

6 mm BOLT

SUBHARNESS

20. Torque the 6 mm bolt to **9.4 N•m (6.9 lb-ft)**. Tighten the subharness band clip and cut off the excess band.

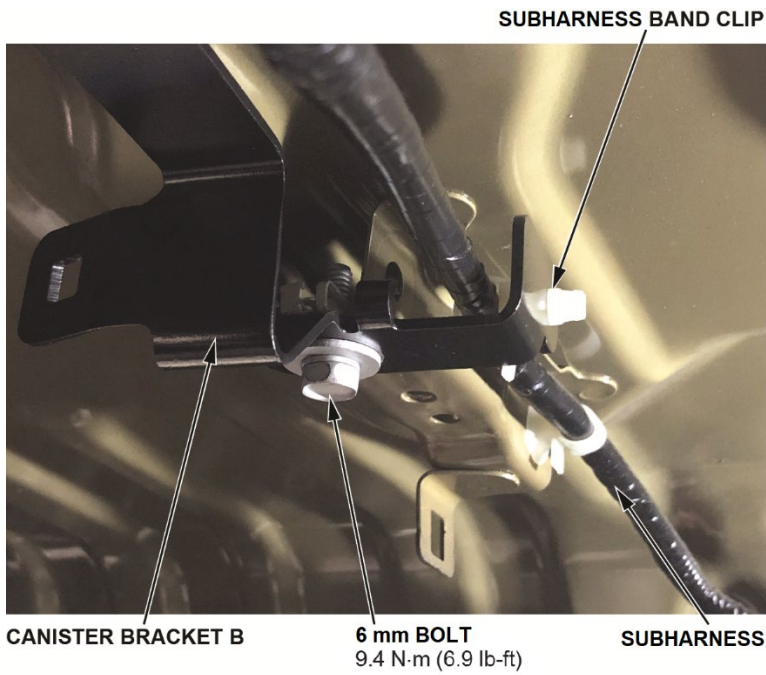

21. Transfer the original EVAP canister vent shut valve and vent pressure sensor to the new EVAP canister.
NOTE: Do not reuse the original O-rings and quick-connect retainer.

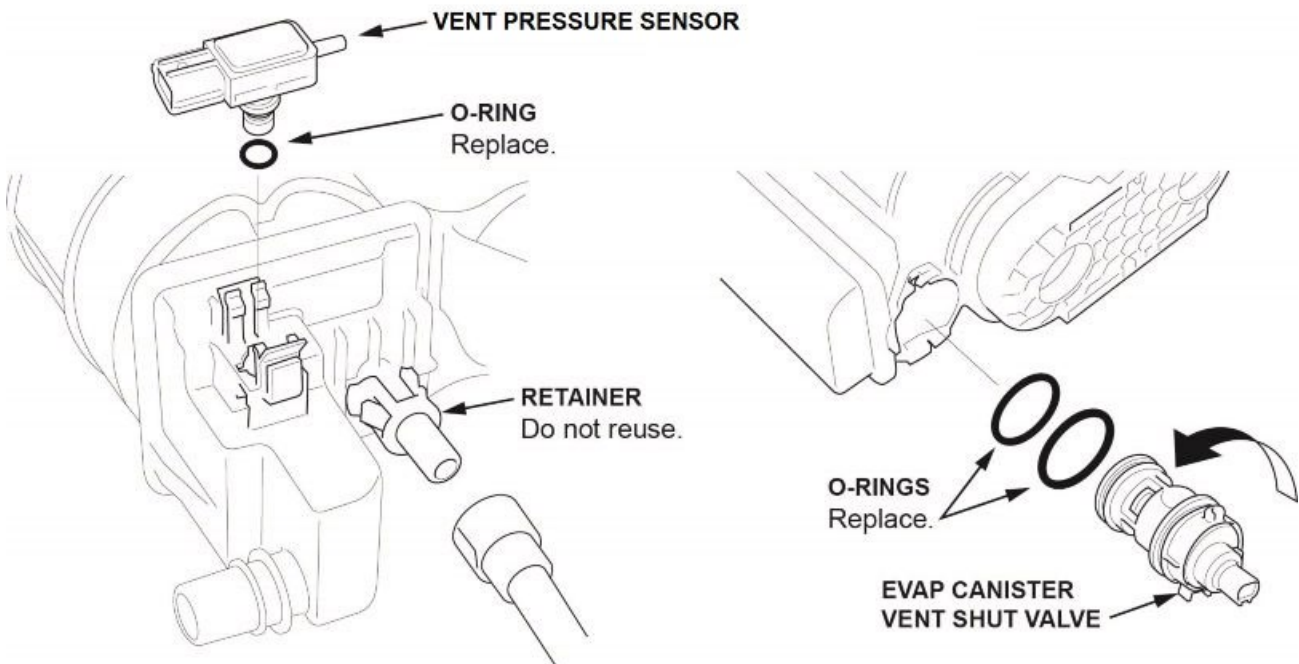

22. Install the new EVAP canister. Torque the bolt to **9.4 N•m (6.9 lb-ft)**.

23. Connect the quick-connect fitting, hoses, and connectors to the EVAP canister.

24. Attach the drain tube joint (P/N 17742-SWA-A01) to drain tube C (P/N 17745-TG7-A30) included in the canister drain kit as shown.



Attach to canister filter box.

DRAIN TUBE C
Note direction.

DRAIN TUBE JOINT
Attach to original location in frame rail.

Make sure the paint dot on drain tube C is lined up with the tab on the drain tube joint as shown.

RUBBER DRAIN TUBE C

PAINTED DOT

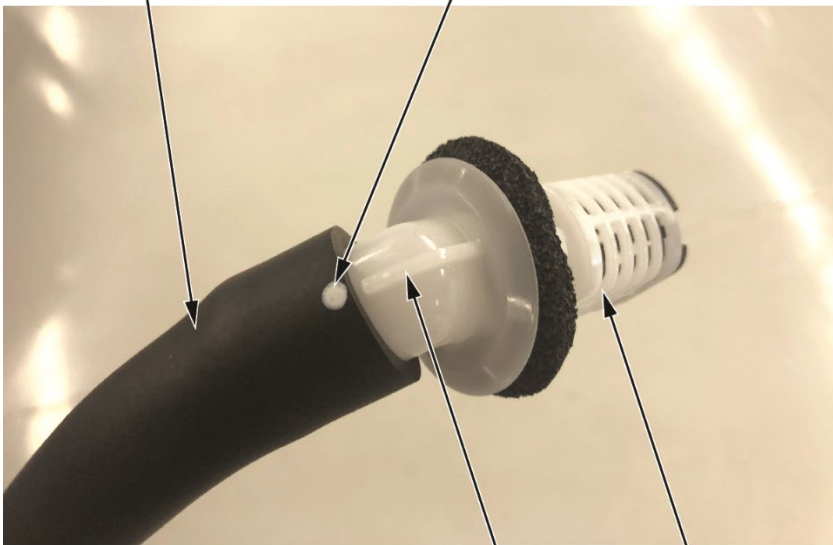

TAB

DRAIN TUBE JOINT

25. Connect the drain tube and drain tube joint assembly to its original location in the frame rail.

26. Connect drain tube A (P/N 17743-TG7-A30) to the EVAP canister. Make sure the paint dot on the drain tube is lined up with the tab on the evap canister.

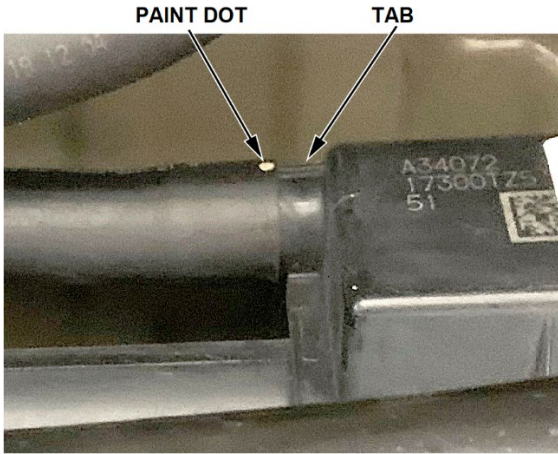

27. Install the new canister filter box to canister bracket A. Use two 6 mm flange nuts (P/N 94050-06040) included in the canister kit, and torque them to **9.4 N·m (6.9 lb-ft)**.

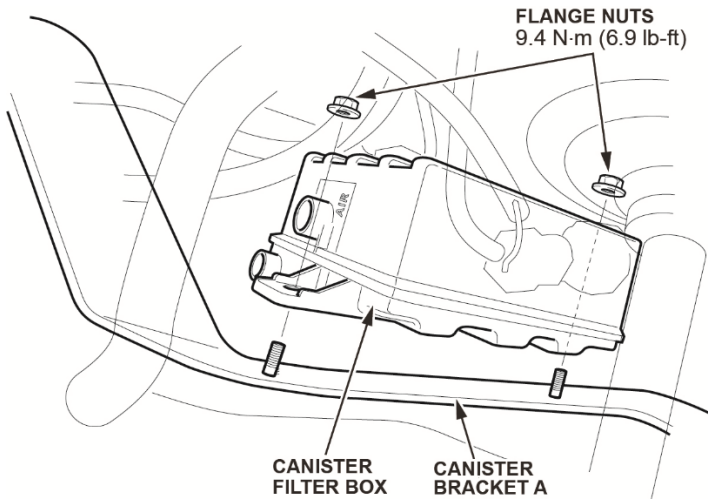

28. Connect drain tube A to the port labeled **CANISTER** on the canister filter box. Connect drain tube C to the port labeled **AIR** on the canister filter box.

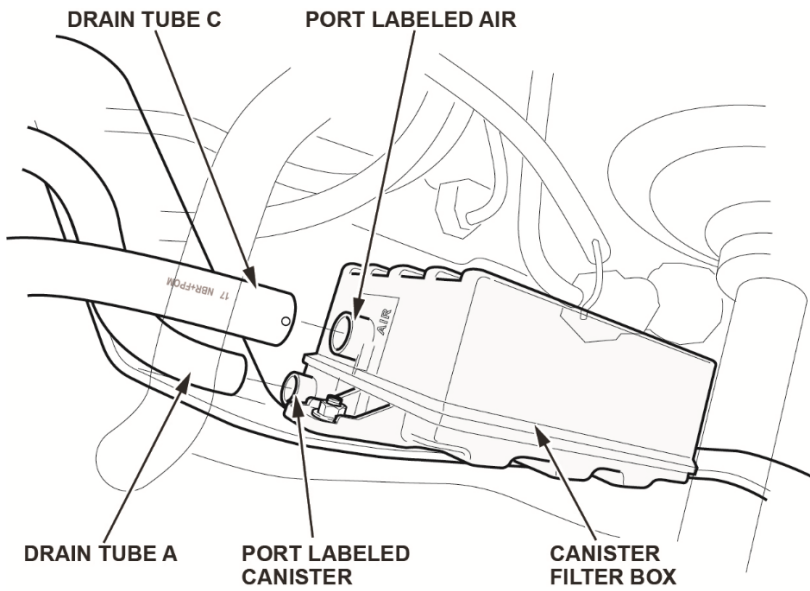

Make sure the paint dot is lined up with the tab on the canister filter box.

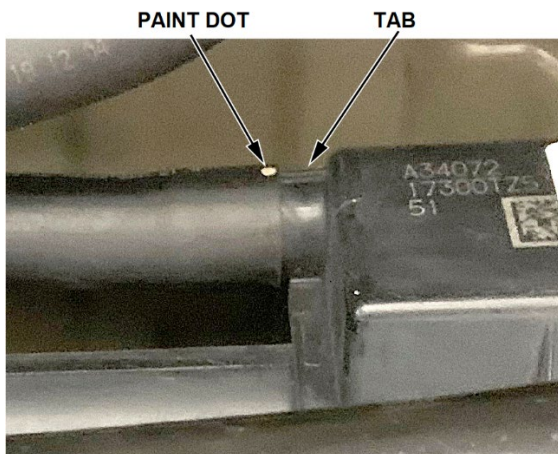

29. Attach drain tube clips (P/N 91595-SCV-A01) included in the canister filter kit to canister bracket B as shown. Then, attach drain tubes A and C to the drain tube clips.

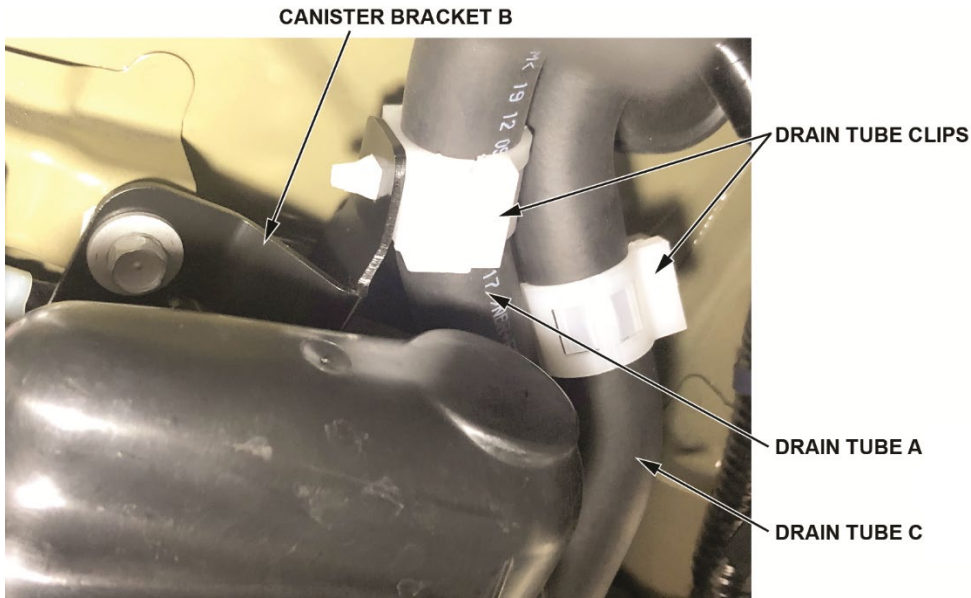

30. Attach drain tube C to drain tube A with the new drain tube clip as shown.

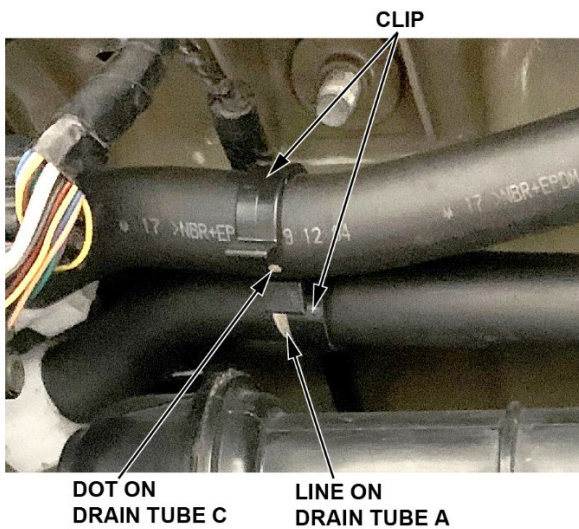

NOTE:

- The clip should line up with the painted line on drain tube A.
- The paint dot on drain tube C should be visible and centered inside the clip.

31. Lower the vehicle to the ground.
32. Before raising the spare tire back into the vehicle, make sure the spare tire hoist bracket is centered in the hub opening of the wheel.
33. Raise the spare tire. If the bracket is correctly positioned, the spare tire will be close to level as it is raised. If the bracket is not correctly positioned, the spare tire will not be level as it is raised and will not seat flush under the vehicle.

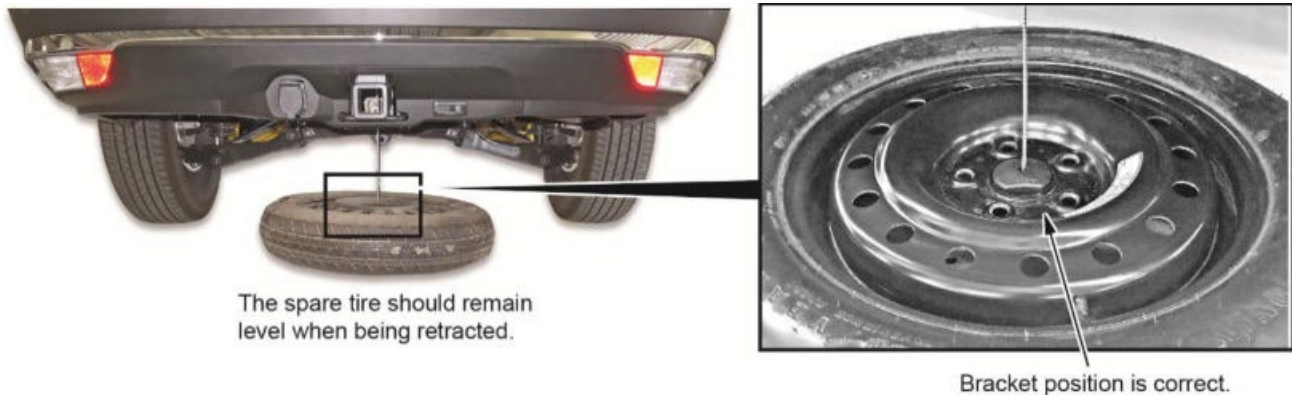

34. Using the appropriate tools in the vehicle, tighten the spare tire hoist until it clicks. Failure to do this can result in noise and/or damage to the hoist cable.

NOTE: **Do not** use power tools.

35. Return the tools to their correct storage areas in the vehicle.
36. Connect the i-HDS to the vehicle. Clear any associated DTCs, then do the EVAP function test.
 - If the EVAP function test passes, the repair is complete.
 - If the EVAP function test fails, continue with normal system troubleshooting.

REPAIR PROCEDURE B

1. Using the appropriate tools in the vehicle, lower the spare tire all the way to the ground, and remove it from the hoist cable.

NOTE: **Do not** use power tools.

2. Remove the exhaust pipe and muffler. Refer to the service information.

NOTE: Do not reuse the exhaust nuts or gasket.

3. Disconnect the propeller shaft from the rear differential.

NOTE:

- Do not reuse the propeller shaft bolts.
- Do not allow the propeller shaft to hang from the center support bearing alone. Hang the propeller shaft from the rear subframe using a bungee cord or something similar.

4. Support the rear differential with a transmission jack, and remove the four rear differential front mounting bracket flange bolts and the two rear differential rear mount flange bolts.

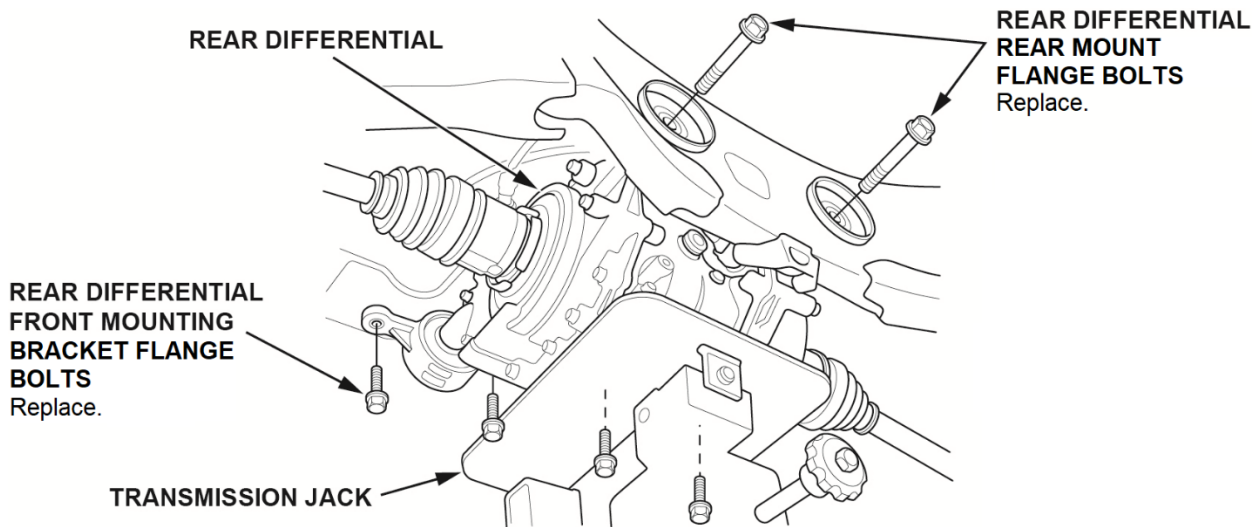

NOTE: Do not reuse the differential mounting flangebolts.

5. Lower the rear differential about **3 in (76.2 mm)**.

NOTE: Make sure you do not stretch the rear differential wiring harness.

6. Disconnect the quick-connect fitting, hoses, and connectors from the EVAP canister.

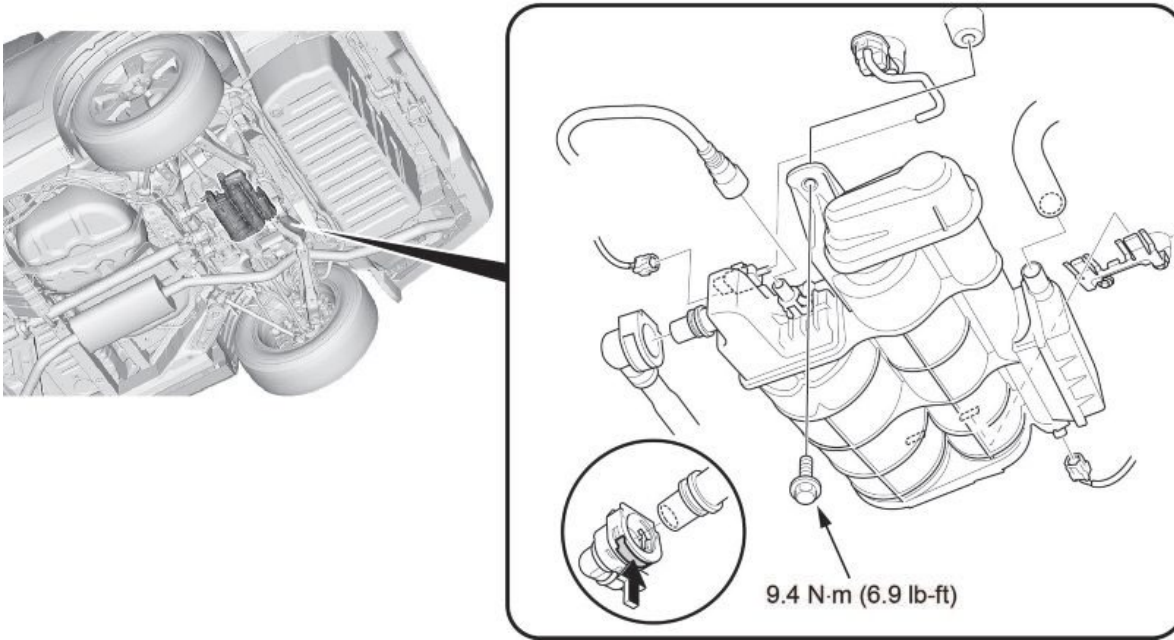

7. Remove and reuse the EVAP canister bolt on the driver's side, then slide the canister toward the driver's side to remove it from the vehicle.
8. Remove the crossmember center brace and flange bolts. Do not reuse them. Replacement parts and hardware are included in the canister drain kit.

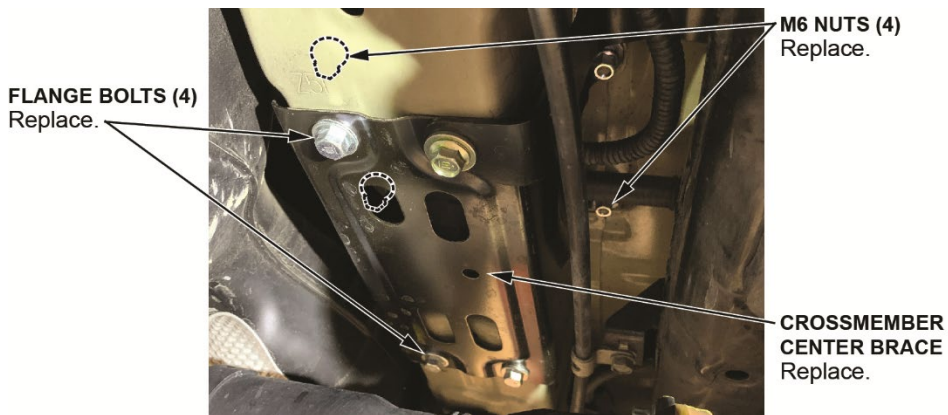

9. Remove the rear left subframe stay and flange bolts. Do not reuse them. Replacement parts and hardware are included in the canister drain kit.

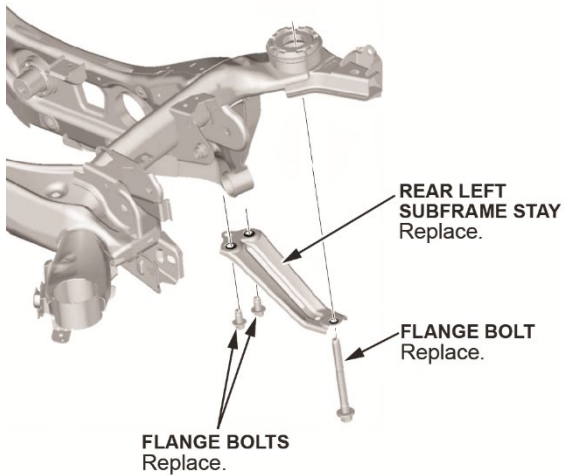

10. Remove the drain tube and drain tube joint connected to the frame rail. Do not reuse the drain tube or drain tube joint.

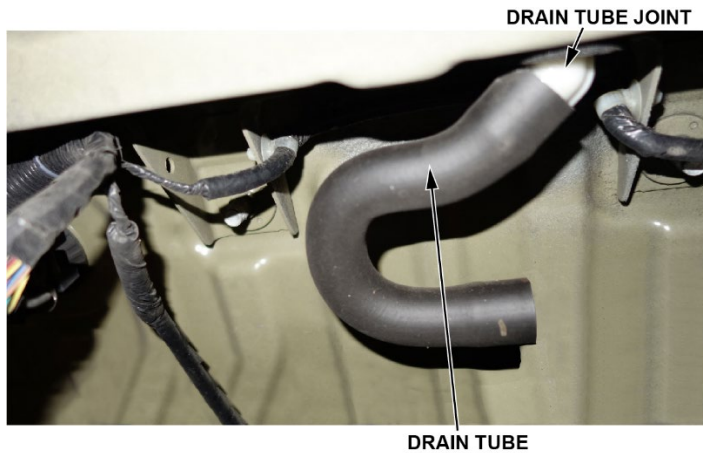

11. Disconnect the rear subframe harness from the crossmember.



REAR SUBFRAME HARNESS
Disconnect.

12. Clean the surrounding area with isopropyl alcohol and cover the hole with the 30 mm door hole seal (P/N 91619-SE0-000) included in the canister drain kit.

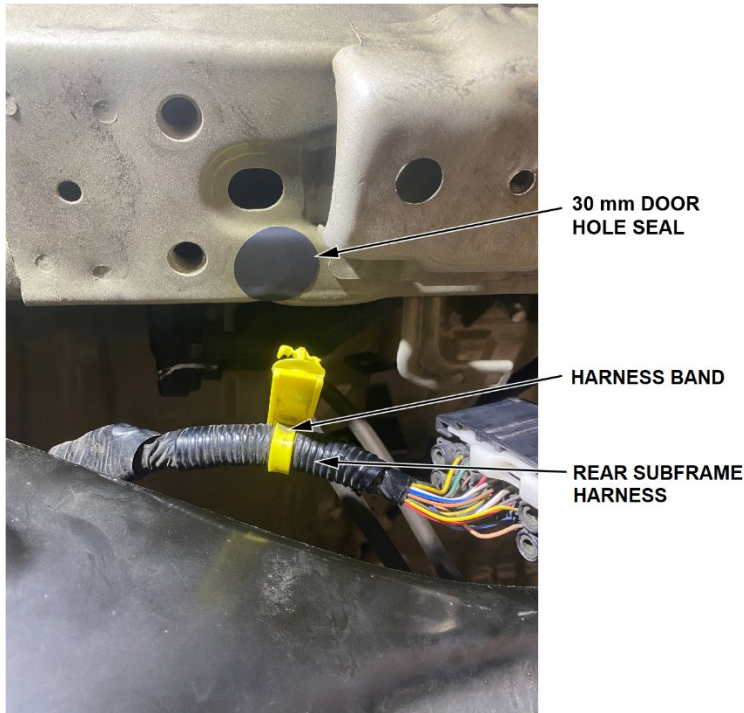

13. Cut the yellow harness band off the rear subframe harness. Make sure you do not damage the harness.
14. Loosely install the new crossmember center brace (P/N 75647-TZ5-A01) and canister filter bracket A (P/N 17316-TG7-A30) as shown. Make sure canister filter bracket A is between the 8 x 22 mm bolt (P/N 90162-S09-000) and the crossmember center brace. Use the 8 x 23.5 mm bolts (P/N 90101-SE3-003) and paint cutting M6 nuts (P/N 90361-TZ5-A00) included in the canister drain kit.

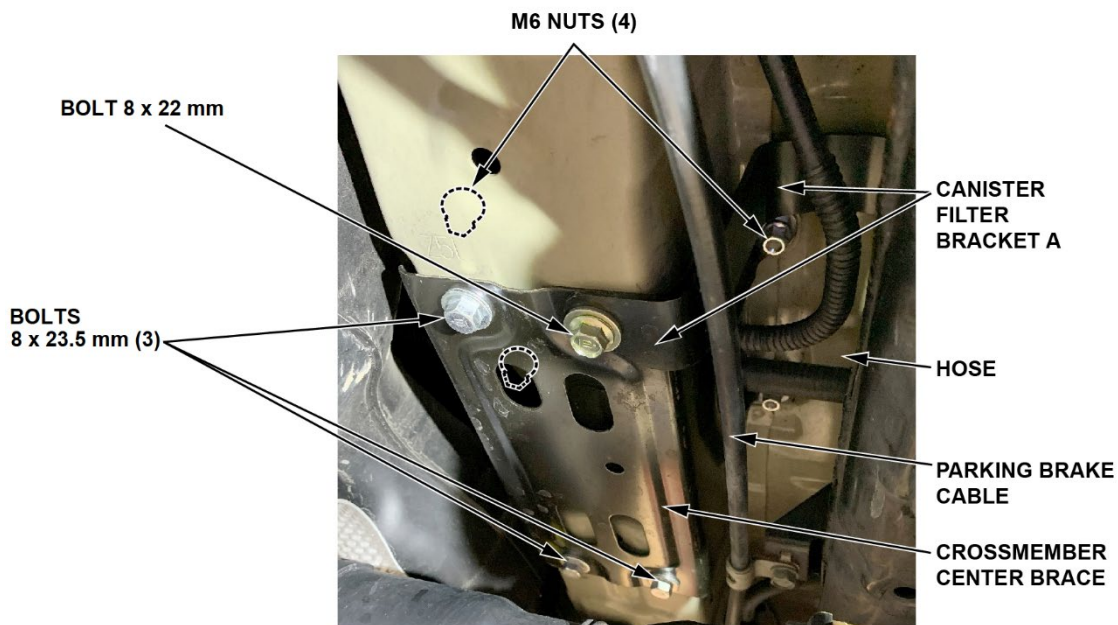

NOTE:

- Tighten the hardware by hand. You will torque them to specification in a later step.
- Make sure canister filter bracket A is routed above the hoses.
- Attach canister bracket A as shown.

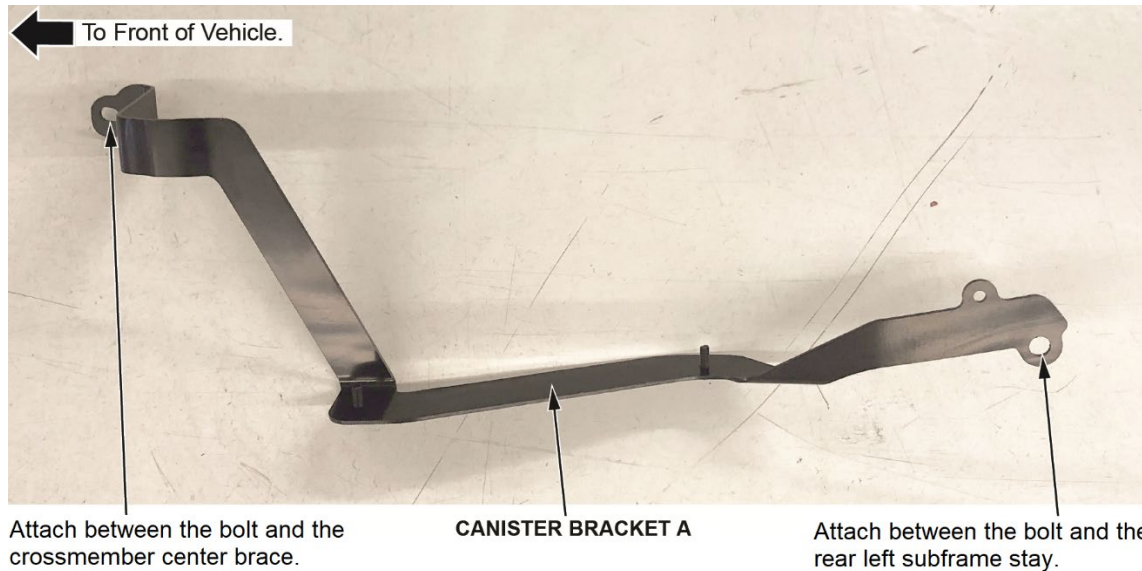

15. Loosely install the new rear left subframe stay (P/N 50378-TG7-A02). Make sure canister filter bracket A is between the flange bolt (P/N 90161-SHK-A00) and rear left subframe stay as shown.

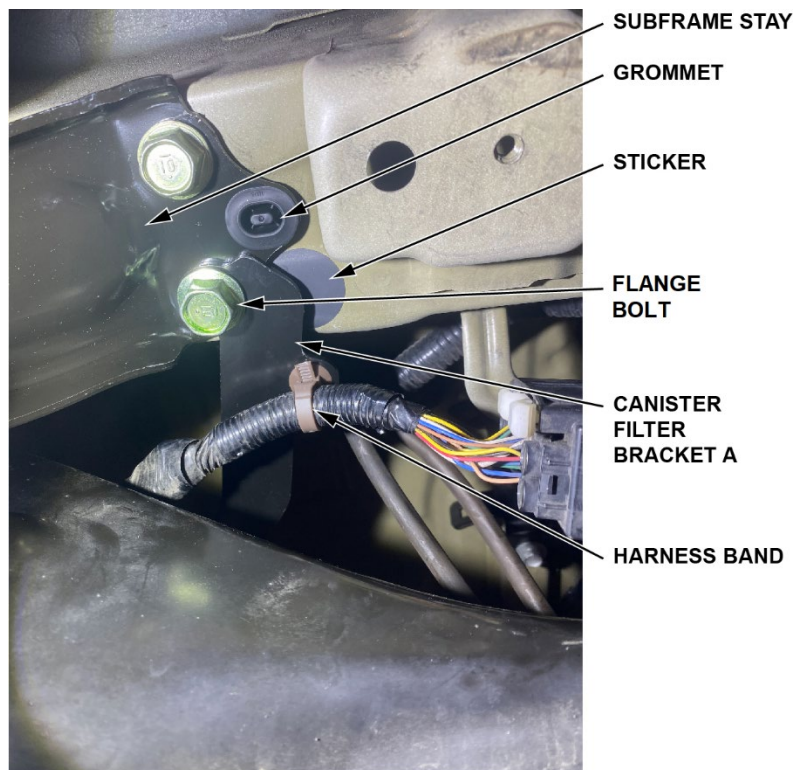

16. Install a new harness band (P/N 91507-SNA-003) included in the canister drain kit, and attach it to the rear left subframe stay as shown.
17. Install a new grommet (P/N 91603-TG7-A02) included in the canister drain kit as shown.

18. Tighten the new flange bolts to the specified torque:

- Torque the 14 x 144 mm bolt (P/N 90161-S3N-000) to **132 N•m (97 lb-ft)**.
- Torque the 12 x 30 mm bolts (P/N 90161-SHJ-A00) to **64 N•m (47 lb-ft)**.

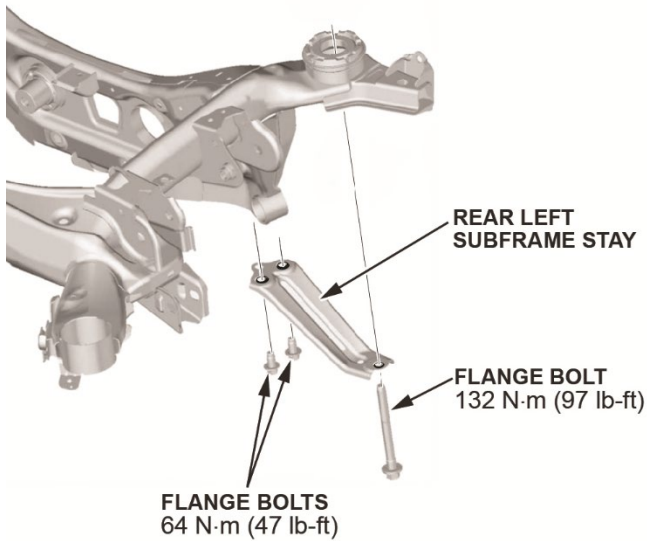

19. Torque the crossmember center brace bolts to **19-25 N•m (14-18.4 lb-ft)**, and torque the nuts to **6.9-12 N•m (5.1-8.9 lb-ft)**.

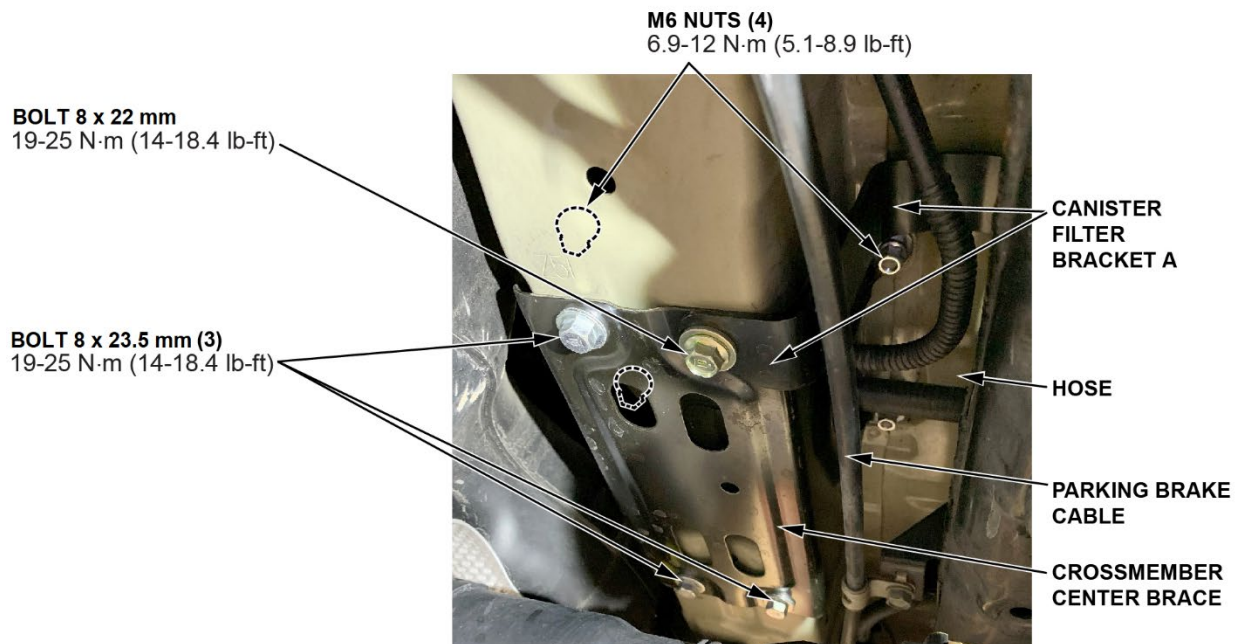

20. Unclip the rear subframe subharness, and install the spring nut (P/N 74103-TZ5-A01) included in the canister drain kit.

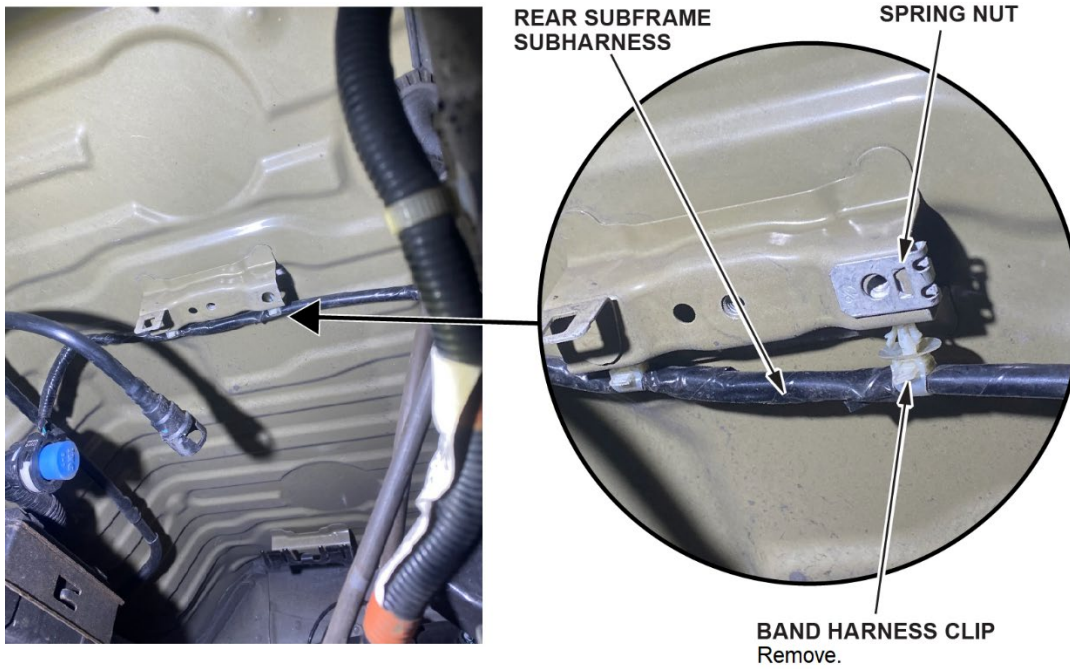

21. Cut the subharness band clip off the harness. Make sure you do not damage the harness.

22. Loosely install the new subharness band clip on the subharness as shown.

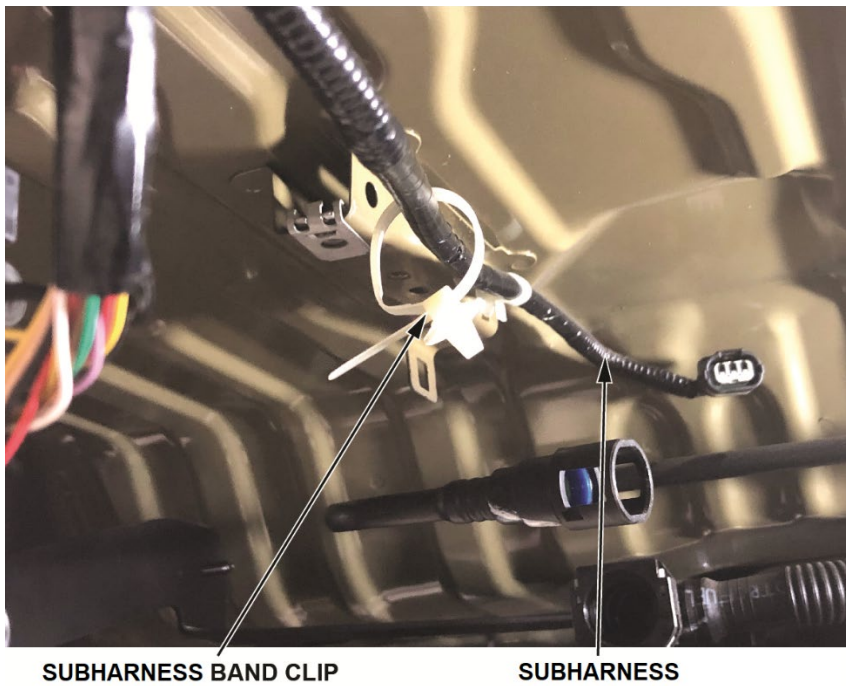

23. Loosely install canister filter bracket B (P/N 17317-TG7-A30) using the 6 mm bolt (P/N 93405-0602004) included in the kit, and attach the subharness band clip as shown.

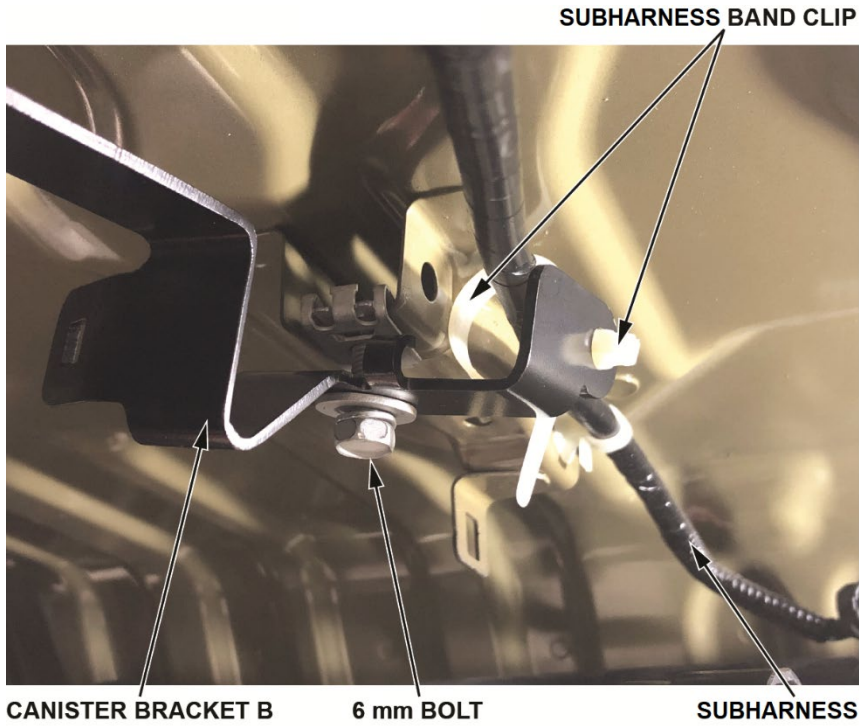

24. Torque the 6 mm bolt to **9.4 N·m (6.9 lb-ft)**. Tighten the subharness band clip and cut off the excess band.

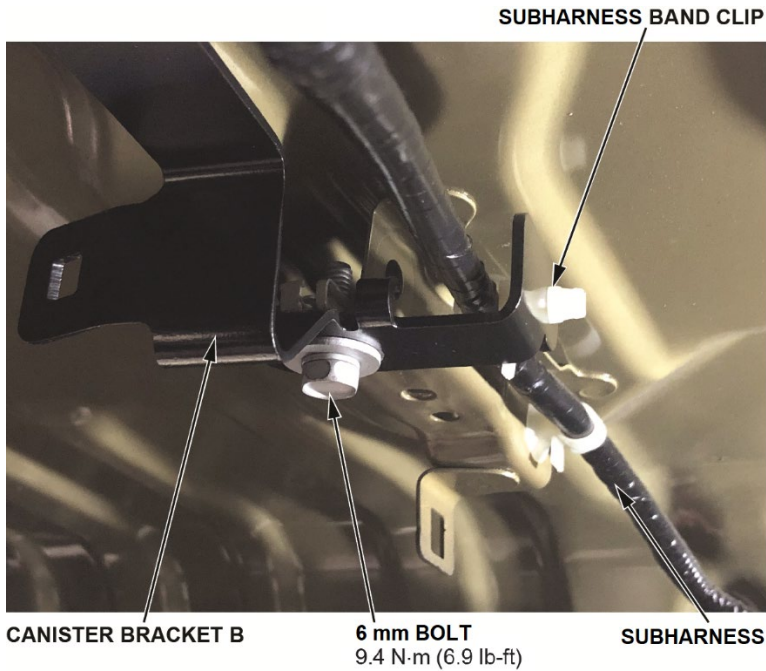

25. Transfer the original EVAP canister vent shut valve and vent pressure sensor to the new EVAP canister.

NOTE: Do not reuse the original O-rings and quick-connect retainer.

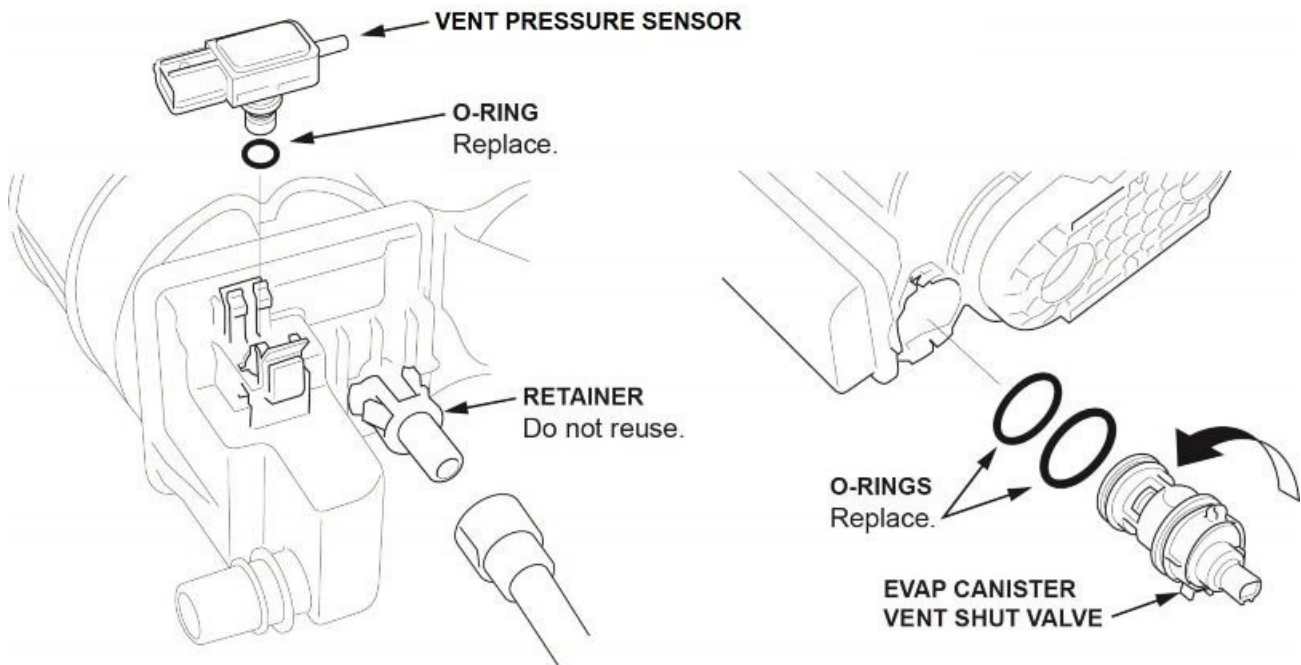

26. Install the new EVAP canister. Torque the bolt to **9.4 N•m (6.9 lb-ft)**.

27. Connect the quick-connect fitting, hoses, and connectors to the EVAP canister.

28. Attach the drain tube joint (P/N 17742-SWA-A01) to drain tube C (P/N 17745-TG7-A30) included in the canister drain kit as shown.



Make sure the paint dot on drain tube C is lined up with the tab on the drain tube joint as shown.

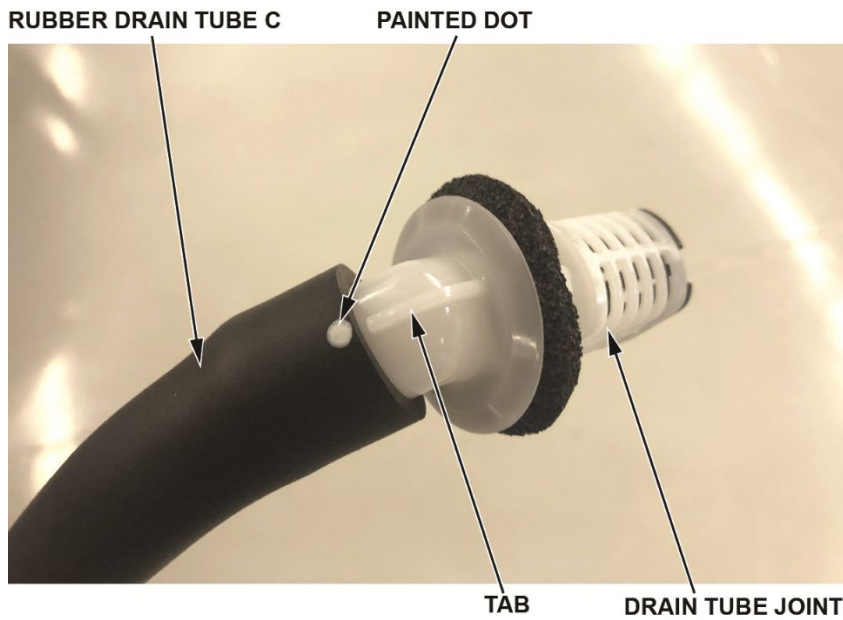

- 29. Connect the drain tube and drain tube joint assembly to its original location in the frame rail.
- 30. Connect drain tube A (P/N 17743-TG7-A30) to the EVAP canister. Make sure the paint dot on the drain tube is lined up with the tab on the evap canister.

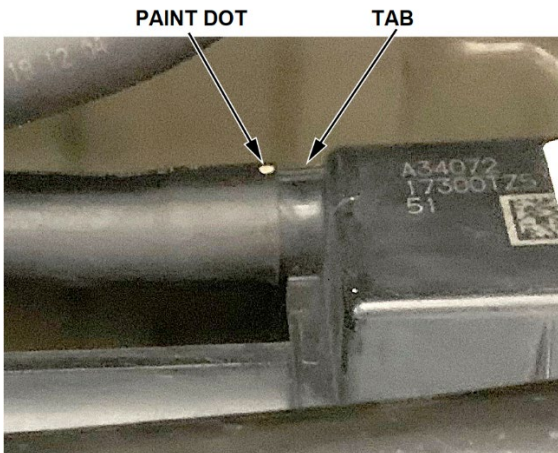

- 31. Install the new canister filter box to canister bracket A. Use two 6 mm flange nuts (P/N 94050-06040) included in the canister kit, and torque them to **9.4 N•m (6.9 lb-ft)**.

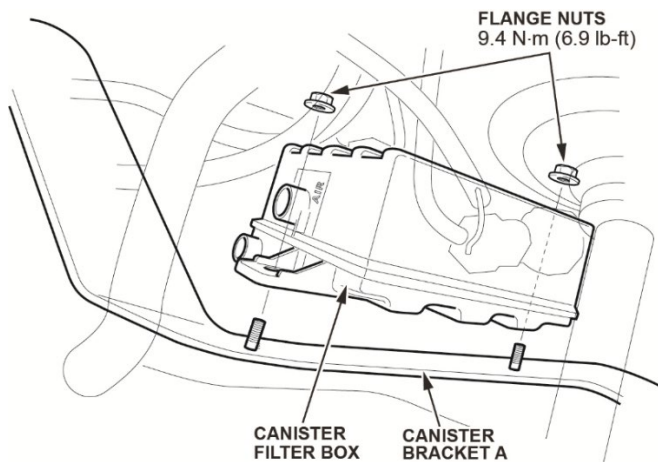

32. Connect drain tube A to the port labeled **CANISTER** on the canister filter box. Connect drain tube C to the port labeled **AIR** on the canister filter box.

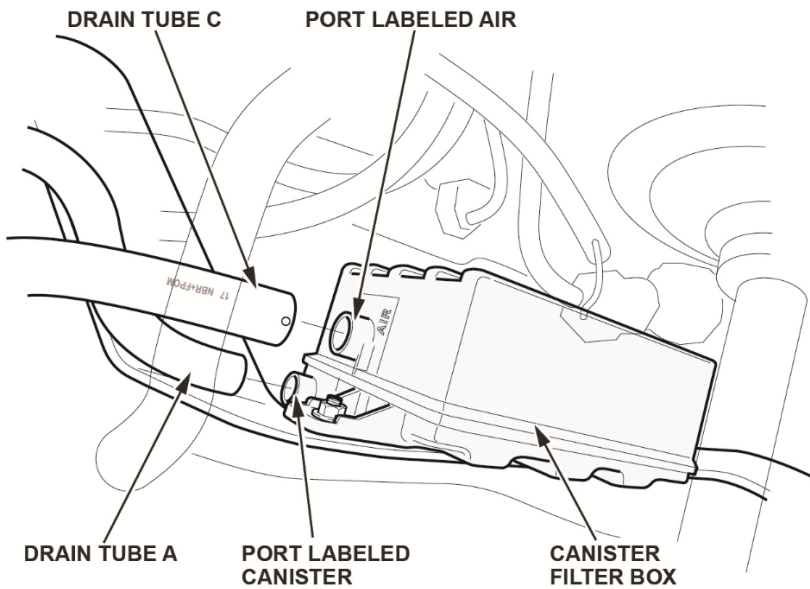

Make sure the paint dot is lined up with the tab on the canister filter box.

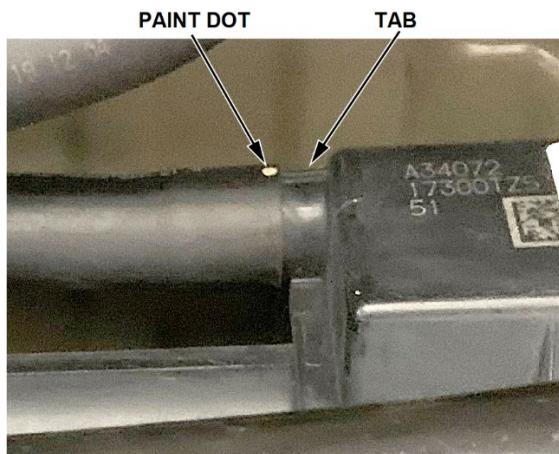

33. Attach drain tube clips (P/N 91595-SCV-A01) included in the canister filter kit to canister bracket B as shown. Then, attach drain tubes A and C to the drain tube clips.

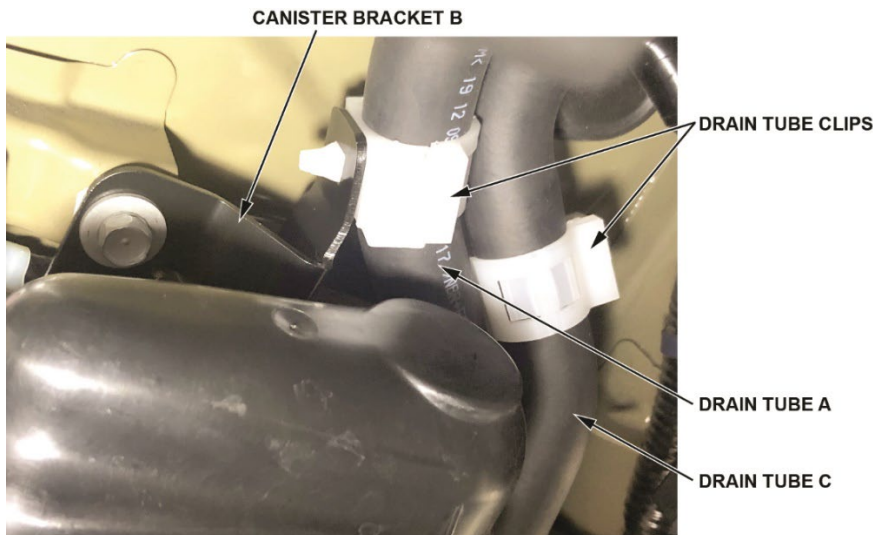

34. Attach drain tube C to drain tube A with the new drain tube clip as shown.

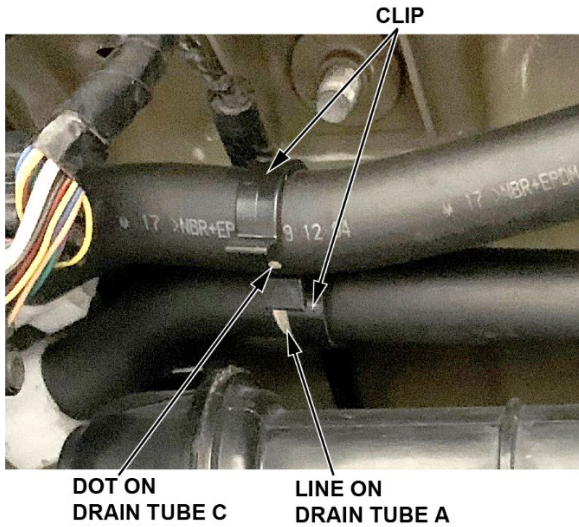

NOTE:

- The clip should line up with the painted line on drain tube A.
- The paint dot on drain tube C should be visible and centered inside the clip.

35. Install the rear differential in the reverse order of removal. Torque the new front bracket flange bolts to **49 N·m (36 lb-ft)**. Torque the new rear mount flange bolts to **69 N·m (51 lb-ft)**.

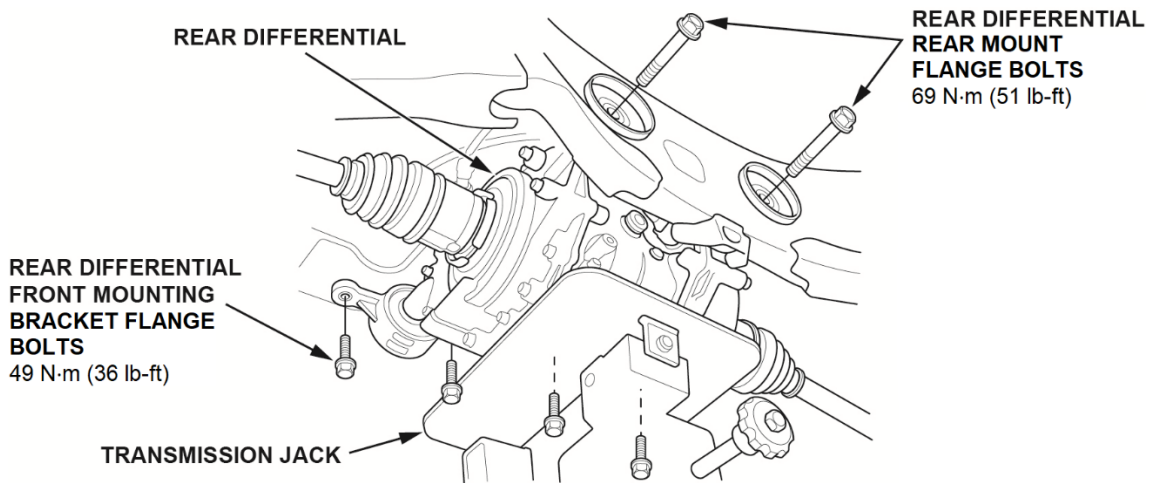

36. Connect the propeller shaft to the rear differential. Torque the new propeller shaft bolts to **32 N•m (24 lb-ft)**.

NOTE:

- Remove the bungee cord securing the propeller shaft before connecting it to the rear differential.
- Make sure you line up the factory reference yellow marks on the propeller shaft and the rear differential input flange.

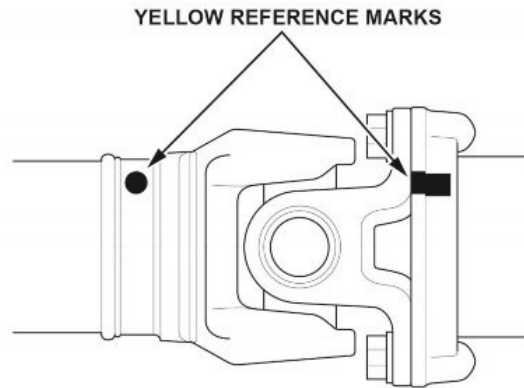
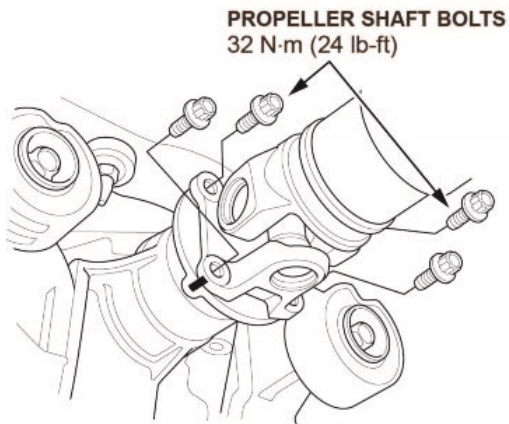

37. Install the exhaust pipe and muffler. Refer to the service information.

NOTE: Do not reuse the exhaust gasket and flange nuts.

38. Lower the vehicle to the ground.

39. Before raising the spare tire back into the vehicle, make sure the spare tire hoist bracket is centered in the hub opening of the wheel.

40. Raise the spare tire. If the bracket is correctly positioned, the spare tire will be close to level as it is raised. If the bracket is not correctly positioned, the spare tire will not be level as it is raised and will not seat flush under the vehicle.



The spare tire should remain level when being retracted.

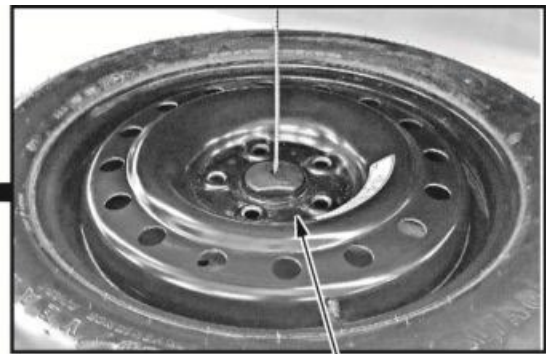

Bracket position is correct.

41. Using the appropriate tools in the vehicle, tighten the spare tire hoist until it clicks. Failure to do this can result in noise and/or damage to the hoist cable.

NOTE: **Do not** use power tools.

42. Return the tools to their correct storage areas in the vehicle.

43. Connect the i-HDS to the vehicle. Clear any associated DTCs, then do the EVAP function test.

- If the EVAP function test passes, the repair is complete.
- *If the EVAP function test fails*, continue with normal system troubleshooting.

REPAIR PROCEDURE C

NOTE:

- Do this procedure only if the canister filter box has already been installed and needs to be replaced because of dust or dirt contamination.
- If the dots are no longer visible on the tubes, mark them with a paint dot to make sure they are installed correctly on the new canister filter box.

1. Disconnect drain tube A from the canister filter box.

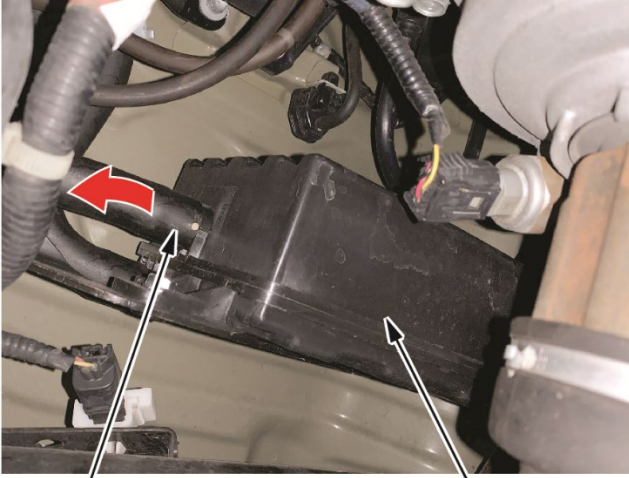

Disconnect the drain tube.

CANISTER FILTER BOX

2. Remove and replace the canister filter box (P/N 17315-TM8-L01). Reuse the two flange nuts, and torque them to **9.4 N•m (6.9 lb-ft)**.

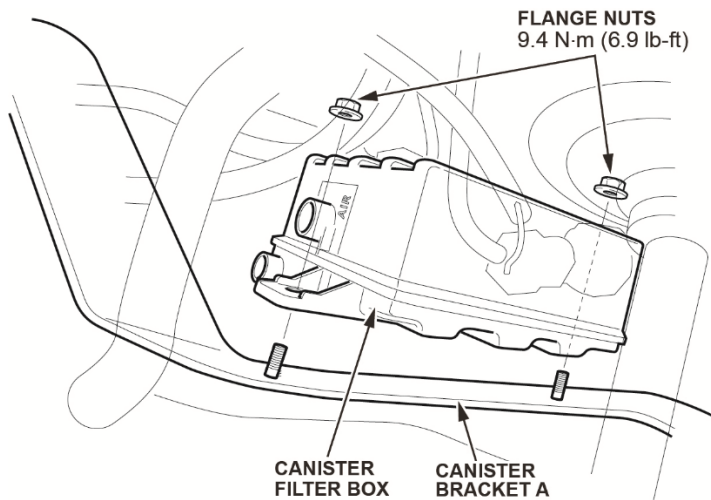

3. Connect drain tube A to the port labeled **CANISTER** on the canister filter box. Connect drain tube C to the port labeled **AIR** on the canister filter box.

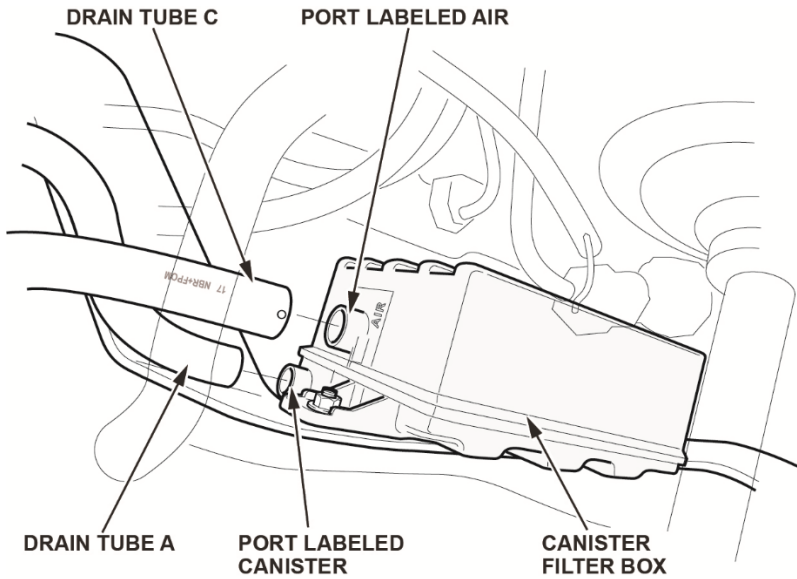

Make sure the paint dot is lined up with the tab on the canister filter box.

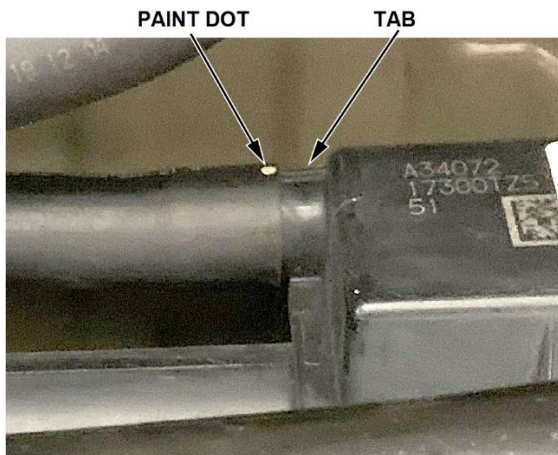

4. Connect the i-HDS to the vehicle. Clear any associated DTCs, then do the EVAP function test.
 - *If the EVAP function test passes, the repair is complete.*
 - *If the EVAP function test fails, continue with normal system troubleshooting.*

END