



RECREATIONAL VEHICLE CUSTOMER SATISFACTION

May 5, 2022

Customer Satisfaction Campaign: 22-425

CUSTOMER SATISFACTION CAMPAIGN

Dear Cougar Customer:

We strive to provide the very best ownership experience in the industry. With this in mind, we are conducting a Customer Satisfaction Campaign at no charge to you for your 2021 - 2022 Cougar Travel Trailers and Fifth Wheels. With some models and features, the Display Commander (LCD screen) for the In-Command system, may exhibit erratic readings on HVAC and/or lose communication with components. This is caused because Keystone may not have installed an End of Line (EOL) Resistor in the "Gateway" located in the Roof A/C. This resistor is installed in the last component in the line of components that communicate with the In-Command system. We apologize if you have experienced this issue; however your continued satisfaction is of the utmost importance to us.

Why are you receiving this notice?

If you are experiencing the following symptoms on your Cougar, the EOL resistor may not be installed and further action is needed:

- -F° temperature readings on LCD display.
- Freezing or lagging functions on the LCD display.
- No communication with components linked to LCD display.

A reset of the In-Command system may provide temporary relief, but some or all of these symptoms may return until the EOL resistor is properly installed.

What will we do?

We have included the EOL resistor with this letter and the instructions for installation are included below. However, if you are not comfortable in any way addressing this yourself, at your earliest convenience, please make arrangements for your Keystone dealer to remedy this for you at no charge to you.

If you have questions

If your dealer is unable to assist or if you take your RV to your dealer on the agreed service date, and the dealer does not remedy the condition within a reasonable amount of time, or without charge to you, please contact Keystone Customer Service by calling 1-866-425-4369.

Thank you for your attention and cooperation in this matter.

Sincerely,
KEYSTONE RV COMPANY

Remedy Overview

The remedy is to turn off the Roof Air Conditioner(s) (A/C), remove the return air grill, locate the Gateway and inspect for the End of Line (EOL) Resistor. The Gateway is a device that allows components to communicate with the In-Command system in order to operate. The resistor must be installed in the last component in the system so In-Command knows there are no other components in the line. Without the EOL resistor, In-Command will continue to search for the last component which leads to intermittent operation and the errors previously described.

Figure 1-Shows a Gateway, the communication cable from In-Command system and the EOL resistor as it should be for proper operation.

We have identified 3 possible scenarios:

PO Box 2000 Goshen, IN 46527-2000
Phone: (574) 535-2100 – Fax: (574) 535-2199
www.keystonerv.com

1. System with one Roof A/C. Turn off the A/C, remove the return air grill, and locate the Gateway (See Figure 2). If there is an open port as seen in Figure 2 & 3, corrective action is needed. Upon completion, the wiring should be as seen in Figure 1.
2. System with two Roof A/C's. Turn off the A/C's, remove the return air grill, and locate the Gateway's. The EOL will need to be installed on the 2nd A/C's Gateway. The first A/C Gateway (typically the middle of the unit) will have two communication cables plugged in (See Figure 4). One cable from In-Command to the 1st A/C, one cable from the 1st A/C to the 2nd A/C. The second A/C Gateway should look like Figure 1, if not, take corrective action.
3. System with one Roof A/C and Pre-Wired for 2nd A/C. If Pre-Wired for 2nd A/C, the 1st A/C Gateway may have two communication cables plugged in, See figure 4. One cable from In-Command to the 1st A/C, one cable from the 1st A/C to the 2nd A/C. The 2nd A/C communication cable will need to be unplugged and the EOL Resistor will need to be plugged in to that port. See Figure 1. The 2nd communication cable can be left protected and unplugged. To determine which communication cable is "live" unplug one cable at a time and operate the A/C functions at the In-Command panel.
4. Note: When a 2nd A/C is installed later, unplug the EOL resistor from the 1st Roof A/C Gateway, reinstall the 2nd A/C communication cable. Install the Pre-wired Communication cable and the EOL resistor into the 2nd A/C Gateway as seen in Figure 1.

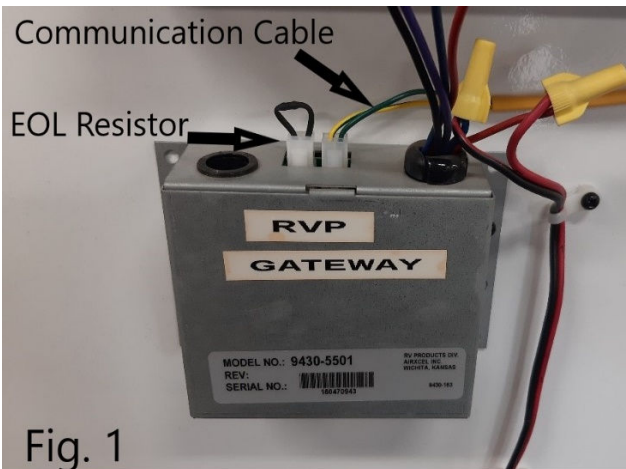

Fig. 1

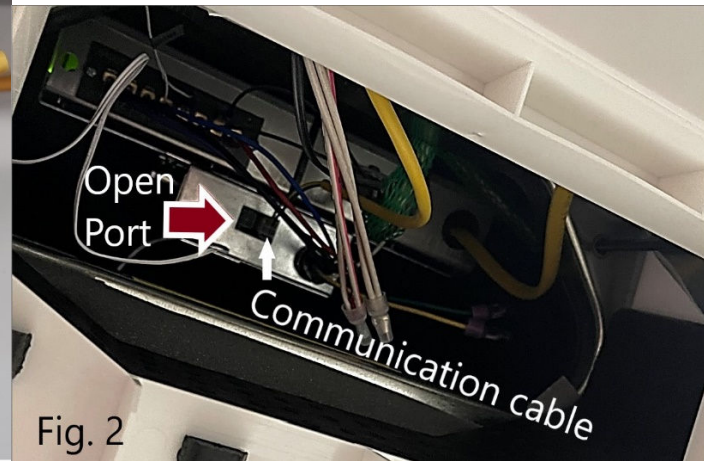

Fig. 2

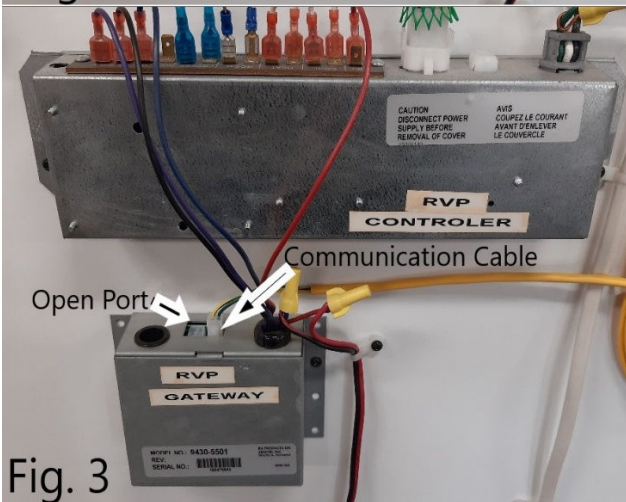

Fig. 3

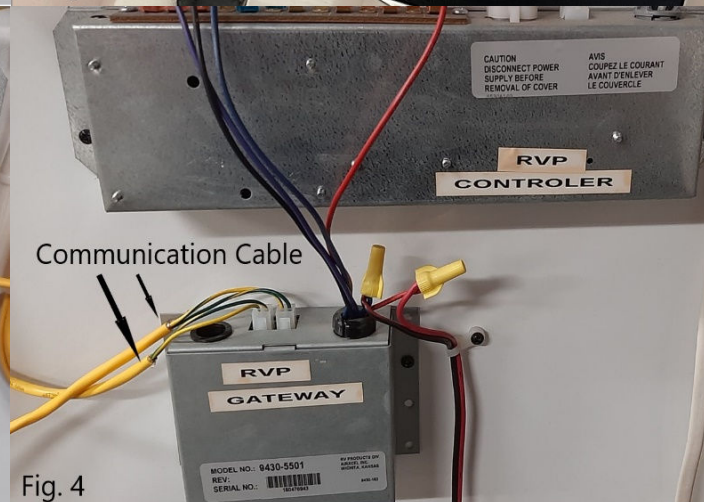

Fig. 4