



Preliminary Information

PIT5287H Diagnostic Tip - Front Shock Terminal Removal

Models

Brand:	Model:	Model Years:	VIN:		Engine:	Transmissions:
			from	to		
Cadillac	Escalade Models	2015 - 2020	All	All	All	All
Chevrolet	Corvette	2020 - 2022	All	All	All	All
Chevrolet	Silverado	2015 - 2018	All	All	All	All
Chevrolet	Silverado LD	2019	All	All	All	All
Chevrolet	Suburban	2015 - 2020	All	All	All	All
Chevrolet	Tahoe	2015 - 2020	All	All	All	All
GMC	Sierra	2015 - 2018	All	All	All	All
GMC	Sierra Limited	2019	All	All	All	All
GMC	Yukon Models	2015 - 2020	All	All	All	All

With Magnetic Ride Suspension Package (RPO Z95)

Supersession Statement

This PI was superseded to update the Recommendation and Models. Please discard PIT5287G.

The following diagnosis might be helpful if the vehicle exhibits the symptom(s) described in this PI.

Condition / Concern

Certain repairs to the front suspension require the removal of the front shock electrical connector terminals. Because the terminals are positioned deep into the connector body, it may be difficult to remove the terminals.

Note: If the shock is being replaced under warranty, do NOT cut the connector off. The wiring needs to stay intact when the shock is returned to engineering for testing.

Recommendations / Instructions

Note: If the shock is being replaced under warranty, do NOT cut the connector off. The wiring needs to stay intact when the shock is returned to engineering for testing.

Use terminal release tool J-38125-554 (Delphi # 12152110), shown below.



To release the terminals perform the following:

1. While looking down into the connector body at the terminals, there is a purple TPA. Slide the TPA over to expose the terminal release hole openings, as shown below in callouts 1 and 2.

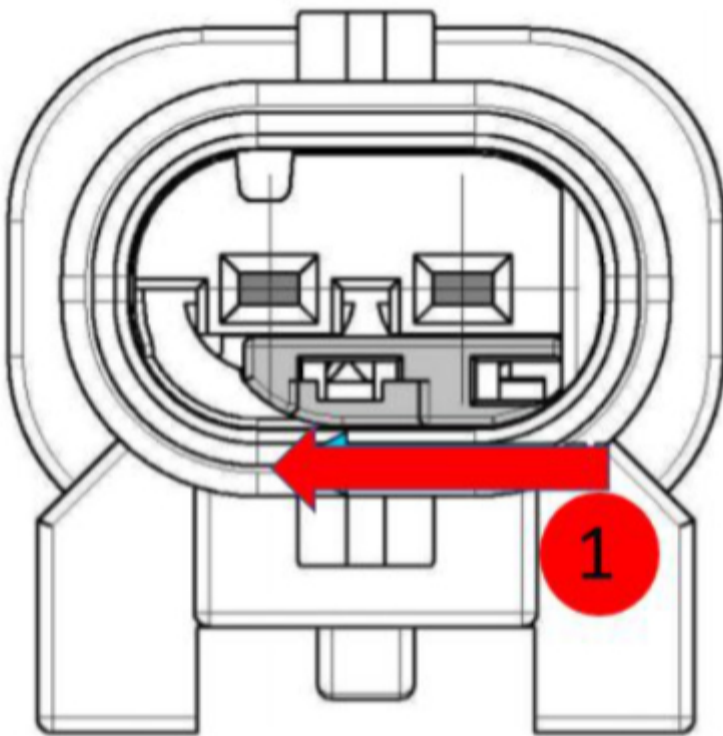

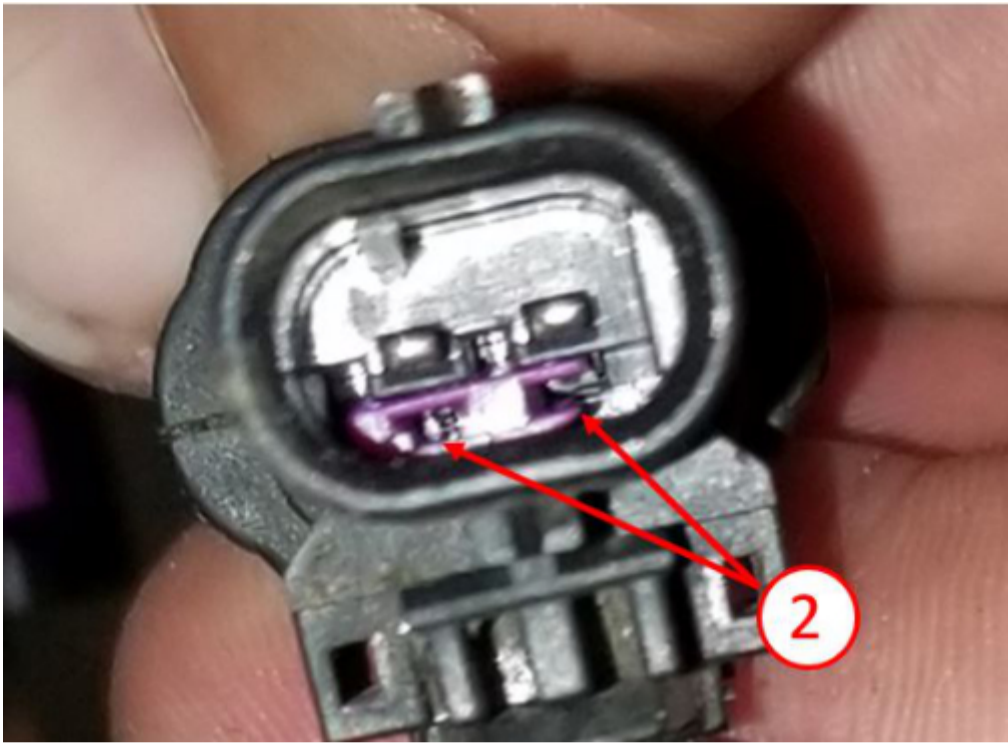

NOTE: While performing step 2, if the wire is slightly pushed into the connector body, it will relieve some of the pressure from the terminal's locking tab and make it easier to release the terminal.

2. Next, insert the terminal release tool J-38125-554 (Delphi # 12152110) into one of the terminal release holes. Then, tilt the release tool so that it will push in on the terminal's release tab, as shown below in callout 3. The heavy black line in the photo below represents the release tool.

3. Once the terminal's release tab is pushed in, then pull the wire and terminal out the rear of the connector body.

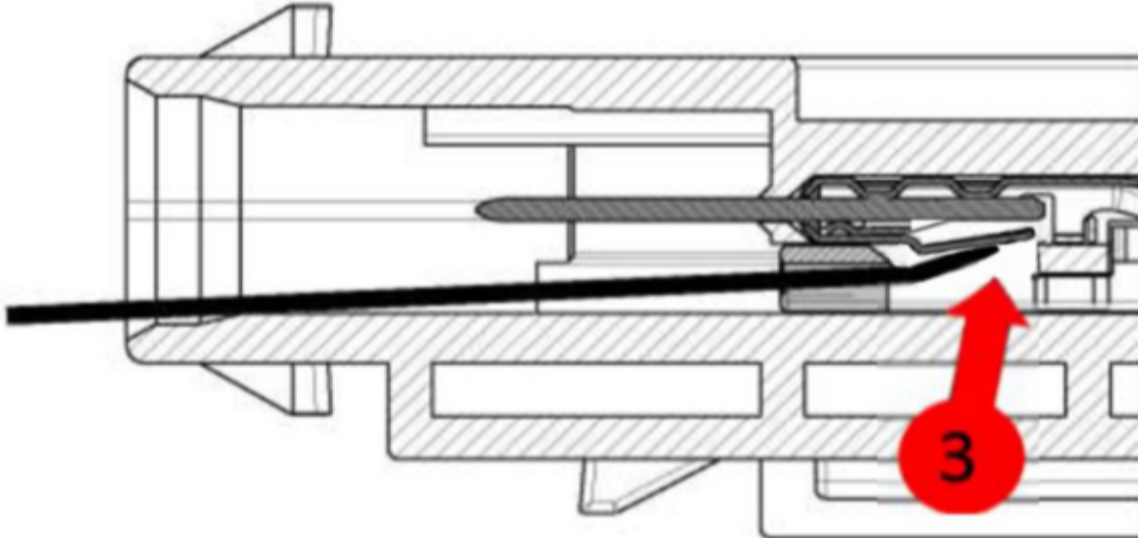

Please follow this diagnostic or repair process thoroughly and complete each step. If the condition exhibited is resolved without completing every step, the remaining steps do not need to be performed.



GENERAL MOTORS

© 2022 General Motors. All Rights Reserved.