

WNA6 - Reworking Fastening Bolts on the Underbody (Workshop Campaign)

Model Line: **Cayenne (9YA/9YB)**

Model Year: **2022**

Concerns: **Fastening bolts on underbody**

Information: **Due to an error during the production process, fastening bolts that do not meet the required specifications were installed on the affected vehicles.**

If, therefore, the tolerances in the body structure are unfavorable, there is a possibility that contact could occur between the fuel tank and fastening bolt while driving and this could result in a fuel tank leak over the service life of the vehicle.

Action required: Remove fastening bolts on underbody. The fuel tank must also be checked for damage and replaced if necessary.

Affected Vehicles: Only vehicles assigned to the campaign (see also PCSS Vehicle Information).

Installation
Position:

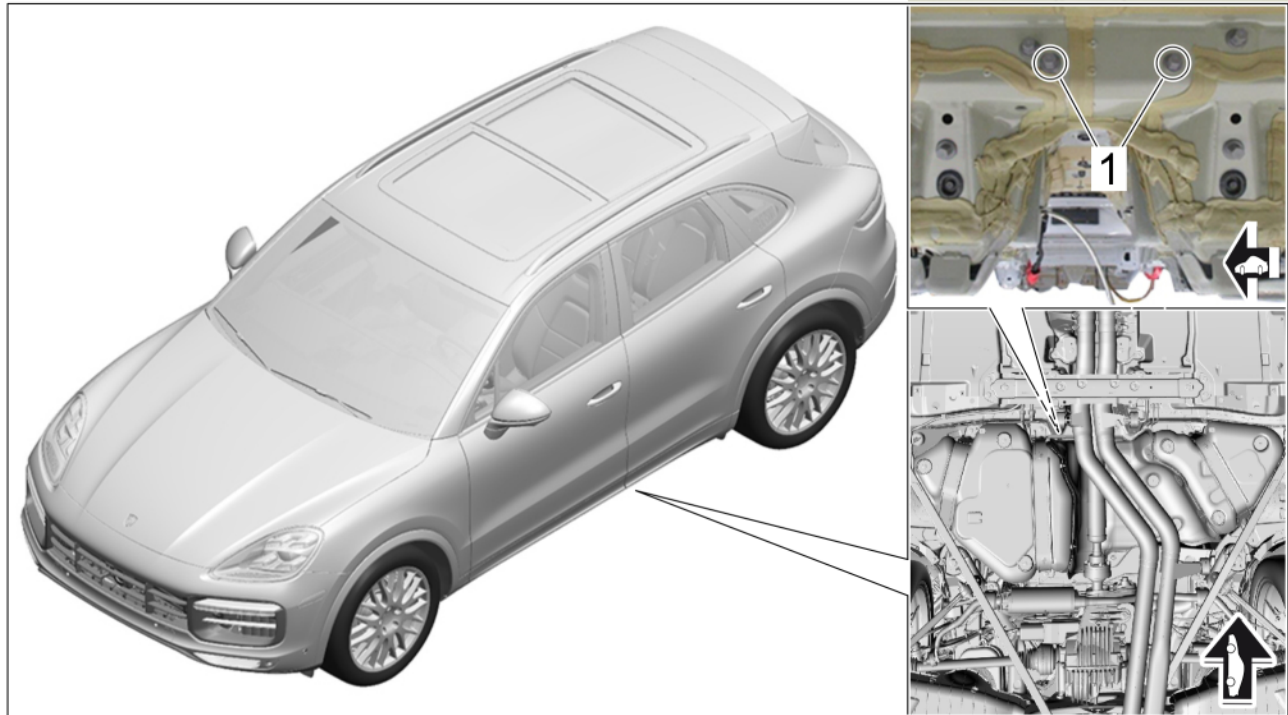

Installation position of fastening bolts

1 – Fastening bolts (removal)

Required parts and materials

Materials:

Part No.	Designation	Quantity
...	Corrosion protection (usually already available at the Porsche dealer)	approx. 2 grams/ 0.07 oz*
Additional parts and materials required, only if floor pan is damaged :		
PAB804535	Seal	up to 2 units (Only if required)

* For guarantee invoicing for Part No. WNA60000001, enter "expendable items" designation as **third-party item**.

Required tools

- Tool:
- Torque wrench, 2-10 Nm (1.5-7.4 ftlbs.), e.g. **VAG 1783 torque wrench, 2-10 Nm (1.5-7.4 ftlbs.)**
 - Torque wrench, 6-50 Nm (4.5-37 ftlb.) e.g. **V.A.G 1331A - torque wrench, 6-50 Nm (4.5-37 ftlb.)**
 - Transmission and aggregate jack, e.g. **VAS 6931 - transmission and aggregate jack**
 - Chisel
 - Hammer
 - Flashlight
 - Mirrors

Removing fastening bolts on underbody

Work Procedure: 1 Raise the vehicle. ⇒ *Workshop Manual '4X00IN Raising the vehicle'*



Information

- The number of screws, clips, electric plug connections, holders and trim panels can vary depending on equipment.
- The illustrations for removing and installing are shown only on one equipment variant and can differ from the actual equipment variant.
- Some steps must be carried out automatically.

2 Remove rear center underbody cover ⇒ *Rear centre underbody cover -3-*.

2.1 Unscrew nut ⇒ *Rear centre underbody cover -2-*.

2.2 Remove expanding rivets ⇒ *Rear centre underbody cover -1-*.

2.3 Unscrew screws ⇒ *Rear centre underbody cover -4-*.

2.4 Remove rear underbody cover at the center ⇒ *Rear centre underbody cover -3-*.

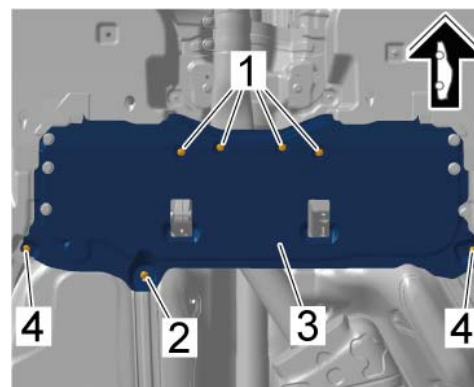

Rear centre underbody cover

- 3 Remove rear underbody cover left and right.
 - 3.1 Unscrew screws ⇒ *Screws on rear underbody cover, left -2-*.
 - 3.2 Remove expanding rivets ⇒ *Screws on rear underbody cover, left -1-*.
 - 3.3 Remove rear left underbody cover ⇒ *Screws on rear underbody cover, left -3-*.

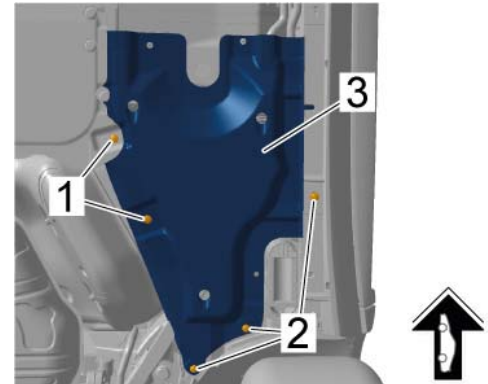

Screws on rear underbody cover, left

- 4 Support the fuel tank ⇒ *Fuel tank on transmission jack (shown as an example) -1-* on a suitable base ⇒ *Fuel tank on transmission jack (shown as an example) -2-* and transmission and gearbox jack ⇒ *Fuel tank on transmission jack (shown as an example) -3-*.

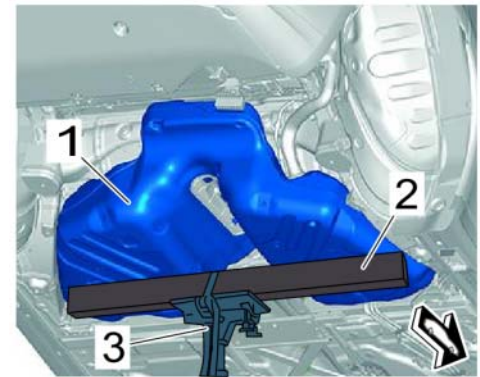

Fuel tank on transmission jack (shown as an example)

- 5 Loosen the fuel tank ⇒ *Fastening the fuel tank -1-*.
 - 5.1 Loosen fastening screws on ⇒ *Fastening the fuel tank -3-* the fuel tank fastening straps as ⇒ *Fastening the fuel tank -4-* far as required until the fastening straps can be moved freely. Do **not** unscrew the fastening screws completely.
 - 5.2 Loosen and unscrew two fastening screws securing the ⇒ *Fastening the fuel tank -2-* fuel tank to the body.

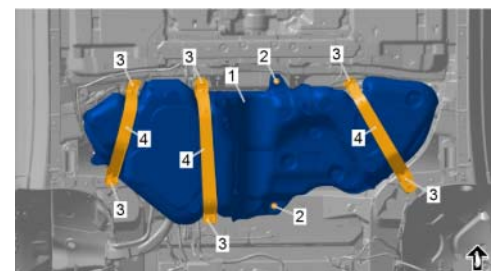

Fastening the fuel tank

- 6 Move fuel tank as far as possible towards the rear axle. To do this, lower the transmission and gearbox jack with the supported fuel tank slightly if necessary.

- 7 Carefully tap off the two fastening bolts (threaded bolts) ⇒ *Removing fastening bolts -1 and 2-* at the welding point using a chisel and hammer. Make sure that the bolts nearby are left ⇒ *Removing fastening bolts -3 and 4-* in the vehicle and are **not** to be tapped.
- 8 Clean the two areas thoroughly with a worn-off bolt using cleaning solution and leave to dry off.
- 9 Then check the two positions using a torch or hand lamp and a mirror ⇒ *Checking floor pan:*
 - **Fastening bolts were tapped off correctly and exactly at the welded points:** Apply corrosion protection to the relevant two areas. Continue with Step 10 (vehicles with Scope 1: Continue with Step 11).
 - **Fastening bolts are worn off and the floor pan was also damaged:** First, seal the damaged area with corrosion protection and leave it to dry off. Then finish with an aluminium butyl. Continue with Step 10 (vehicles with Scope 1: Continue with Step 11).



Removing fastening bolts

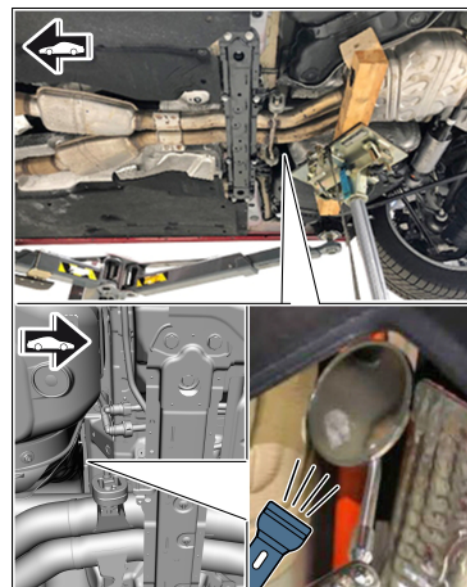

Checking floor pan

- 10 **Only valid for vehicles with Scope 2:** On vehicles with fastening bolts **without** protection caps check the fuel tank for damage.
To do this, check the fuel tank for damage using a pocket torch or hand lamp and a mirror close to the fastening bolts you removed earlier.

- **The fuel tank is damaged by the fastening bolts:** The fuel tank **must be replaced**. To do so, proceed with ⇒ *Workshop Manual '201019 Removing and installing fuel tanks'*. The incurred labor costs and the additional cost of parts required over and above this must then be invoiced using a **reimbursement claim** for the original campaign claim for this campaign. In this case, **photographic documentation is absolutely essential**.
- **Fuel tank is completely undamaged:** Continue with Step 11.

- 11 Move fuel tank into the correct position and tighten the fastening straps again. Tighten screws in the tightening sequence ⇒ *Tightening sequence for tank fastening strap -1 to 4-*.

Tightening torque 20 Nm (14.8 ftlb.)

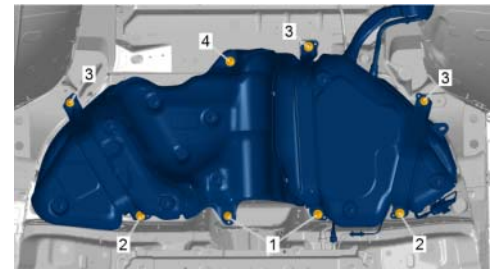

Tightening sequence for tank fastening strap

- 12 Install cover for rear underbody on left and right.
- 12.1 Position rear underbody cover on the left ⇒ *Screws on rear underbody cover, left -3-*.
- 12.2 Install expanding rivets ⇒ *Screws on rear underbody cover, left -1-*.
- 12.3 Tighten screws ⇒ *Screws on rear underbody cover, left -2-*.

Tightening torque 2 Nm (1.5 ftlb.)

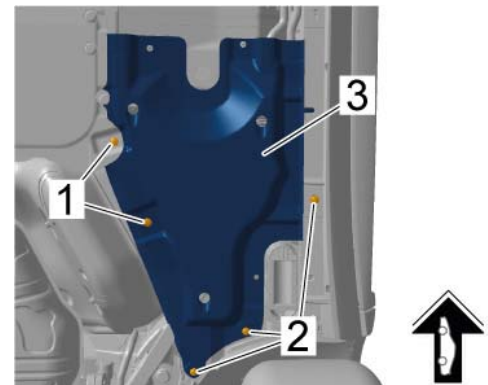

Screws on rear underbody cover, left

- 13 Install rear center underbody cover ⇒ *Rear centre underbody cover -3-*.
- 13.1 Position rear center underbody cover ⇒ *Rear centre underbody cover -3-*.
- 13.2 Screw in and tighten screws. ⇒ *Rear centre underbody cover -4-*

Tightening torque 3 Nm (2.2 ftlb.)

- 13.3 Install expanding rivets ⇒ *Rear centre underbody cover -1-*.
- 13.4 Screw in and tighten nut ⇒ *Rear centre underbody cover -2-*.

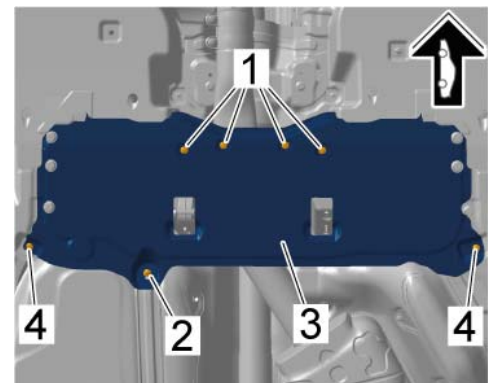

Rear centre underbody cover

Tightening torque 2 Nm (1.5 ftlb.)

- 14 Lower the vehicle and remove it from the lifting platform.
- 15 Enter the campaign in the Guarantee and Maintenance booklet.

Warranty processing



Information

The specified working times were determined specifically for carrying out this campaign and include all required preliminary and subsequent work.
The working times may differ from the working times published in the Labor Operation List in PCSS.

Scope 1: Removing fastening bolts on underbody

Labor time:

Removing fastening bolts on underbody	Labor time: 133 TU
Includes:	
Removing and installing cover for rear center underbody	
Removing and installing cover for rear underbody on left and right	
Loosening and fastening fuel tank	
Required parts and materials	
PAB804535 Seal	up to 2 units (Only if required)
WNA60000001* Expendable items	1 unit*

* For guarantee invoicing for Part No. WNA60000001, enter "expendable items" designation as **third-party part**, amount \$0.63.

⇒ **Damage code WNA6 066 000 1**

Scope 2: Removing fastening bolts on the underbody and checking the fuel tank for damage



Information

If the fuel tank is damaged and has to be replaced, the incurred labor costs and the additional cost of parts required over and above this must then be invoiced using a **reimbursement claim** for the original campaign claim for this campaign. In this case, **photographic documentation is absolutely essential**.

Labor time:

Removing fastening bolts on the underbody and checking the fuel tank for damage Labor time: **136 TU**

Includes: Removing and installing cover for rear center underbody
Removing and installing cover for rear underbody on left and right
Loosening and fastening fuel tank

Required parts and materials

PAB804535	Seal	up to 2 units (Only if required)
-----------	------	-------------------------------------

WNA60000001*	Expendable items	1 unit*
--------------	------------------	---------

* For guarantee invoicing for Part No. WNA60000001, enter "expendable items" designation as **third-party part**, amount \$0.63.

⇒ **Damage code WNA6 066 000 1**

Important Notice: Technical Bulletins issued by Porsche Cars North America, Inc. are intended only for use by professional automotive technicians who have attended Porsche service training courses. They are written to inform those technicians of conditions that may occur on some Porsche vehicles, or to provide information that could assist in the proper servicing of a vehicle. Porsche special tools may be necessary in order to perform certain operations identified in these bulletins. Use of tools and procedures other than those Porsche recommends in these bulletins may be detrimental to the safe operation of your vehicle, and may endanger the people working on it. Properly trained Porsche technicians have the equipment, tools, safety instructions, and know-how to do the job properly and safely. Part numbers listed in these bulletins are for reference only. The work procedures updated electronically in the Porsche PIWIS diagnostic and testing device take precedence and, in the event of a discrepancy, the work procedures in the PIWIS Tester are the ones that must be followed.

© 2022 Porsche Cars North America, Inc.