



Service Bulletin

Bulletin No.: 21-NA-284

Date: January, 2022

TECHNICAL

Subject: 60% Rear Seat Will Not Fold Down

Brand:	Model:	Model Year:		Date Breakpoints:		Engine:	Transmission:
		from	to	from	to		
Cadillac	Escalade Models	2021	2022			All	All
Chevrolet	Suburban						
	Tahoe						
GMC	Yukon Models						

Involved Region or Country	North America, Middle East, Iraq, Israel, Palestine
Additional Options (RPOs)	
Condition	Some customers may comment that the 60% rear seat will not fold down.
Cause	The cause of the condition may be that the seat cable running to the white outboard seat release lever may have become detached.
Correction	Fully detach, then reattach the 60% rear seat cable, and install a reinforcement retainer, following the steps in the Service Procedure below.

Service Procedure



5932659

1. Remove the rear seat adjuster and recliner handles (1), and the rear seat recliner outer finish cover (2). Refer to *Rear Seat Hinge Finish Cover Replacement - Outboard*, in SI.

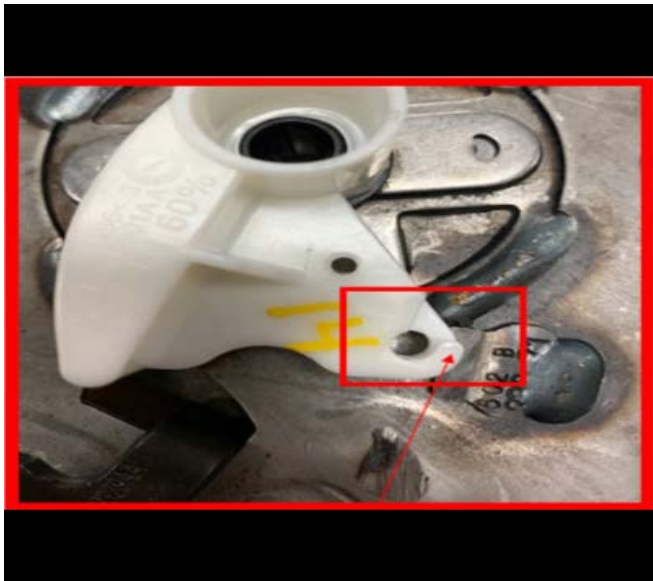

5932660

Note: Inspect outboard white release lever for damage or missing material (1). If damage is found, the entire structure must be replaced.



5932661

2. Verify cable is disconnected from the outboard white release lever.
3. Disconnect the outboard cable fitting:

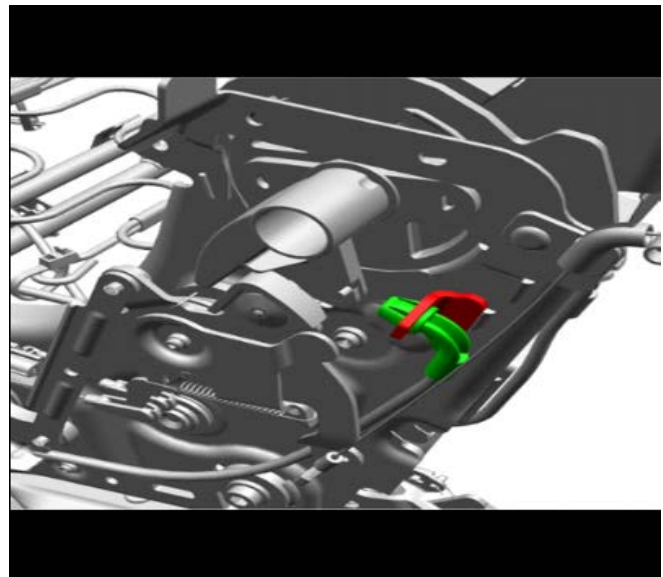

5932662

- 3.1. Remove green cable end fitting from the red bracket.



5932663

- 3.2. Use tool to remove plastic cable end fitting from bracket, by pinching snap fingers and pulling out.

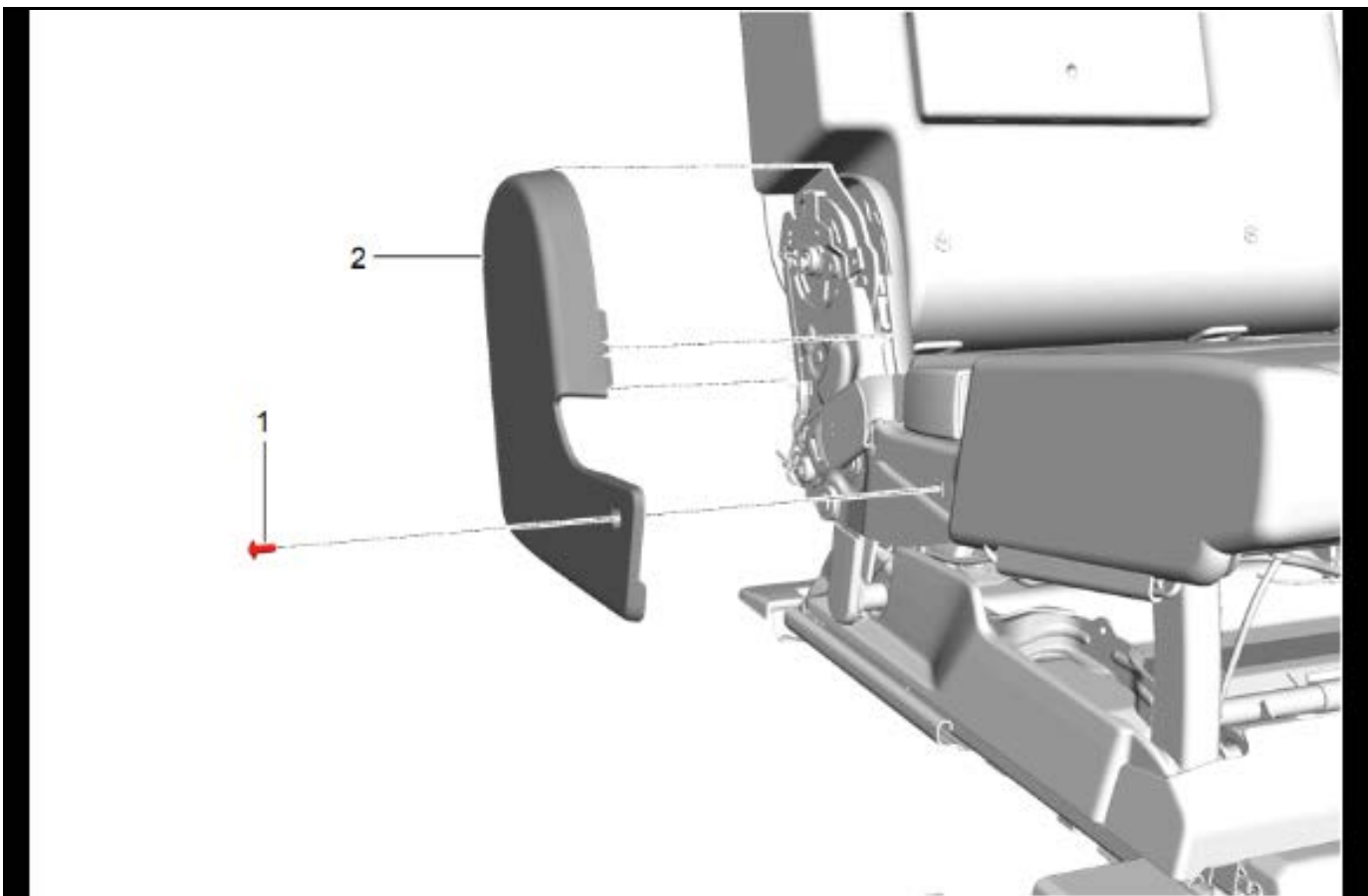

5608391

4. Remove the inboard rear seat hinge finish cover. Refer to *Rear Seat Hinge Finish Cover Replacement - Inboard (Bench)* in SI.
5. Disconnect the inboard lower cable attachment:

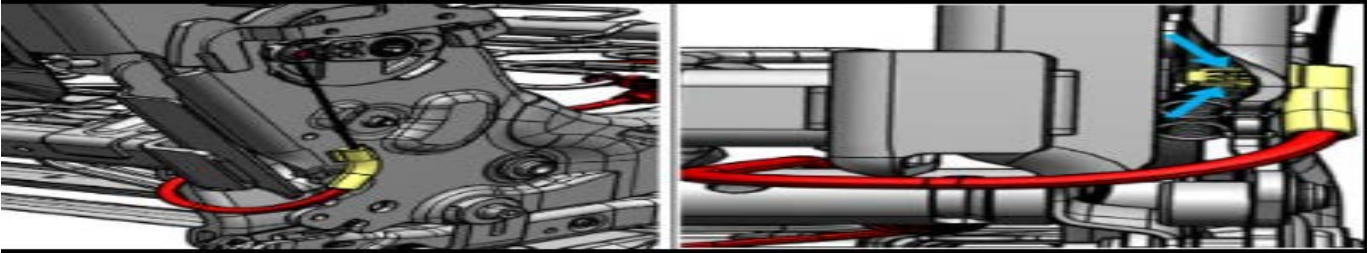

5932664

- 5.1. Using care to **NOT** disconnect the internal latch springs (at blue arrows), remove the yellow cable end fitting.



5932665

- 5.2. Remove fitting by pinching snap fingers and pulling fitting outward.

Note: If the metal cable strand is frayed or kinked, the cable must be replaced.

6. Re-connect the outboard cable fitting:

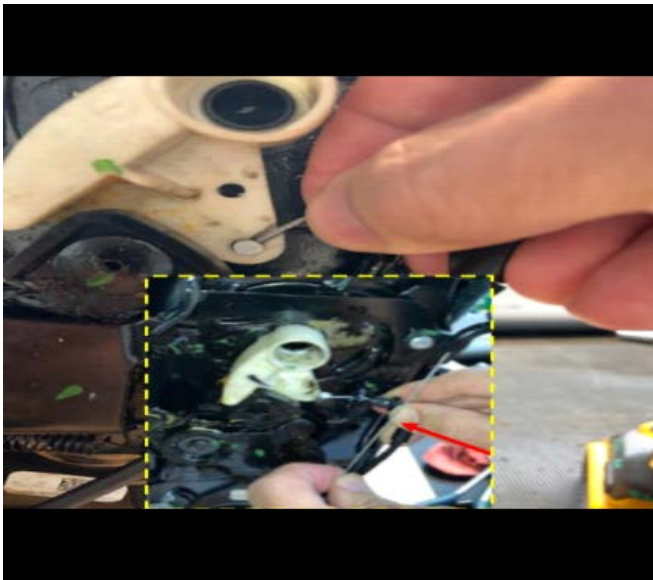

5932666

Note: Ensure you route the cable inside of pull strap cable.

- 6.1. Insert end of cable into lower hole in lever and align cable in slot.

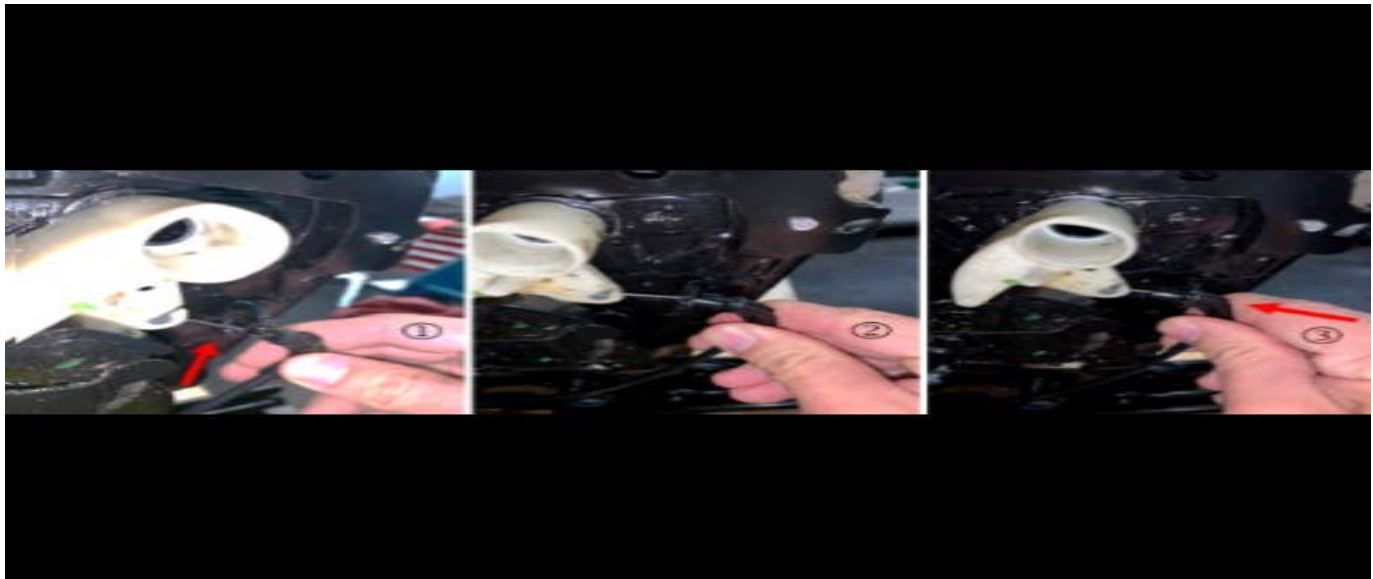

5932667

- 6.2. Rotate cable down and allow metal cable to pass through slot in bracket (1).
 - 6.3. Align fitting with the bracket (2).
 - 6.4. Push fitting forward to snap into bracket (3).
7. Re-connect inboard lower cable attachment:

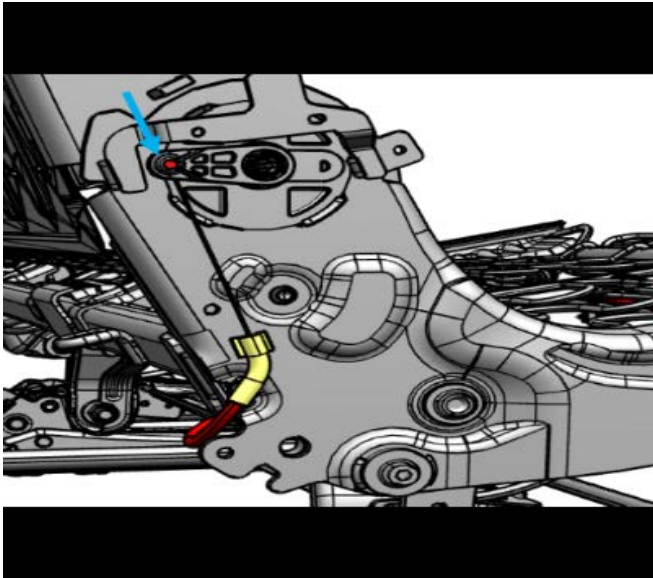

5932668

- 7.1. Make sure red die cast fitting is still attached to the lever.

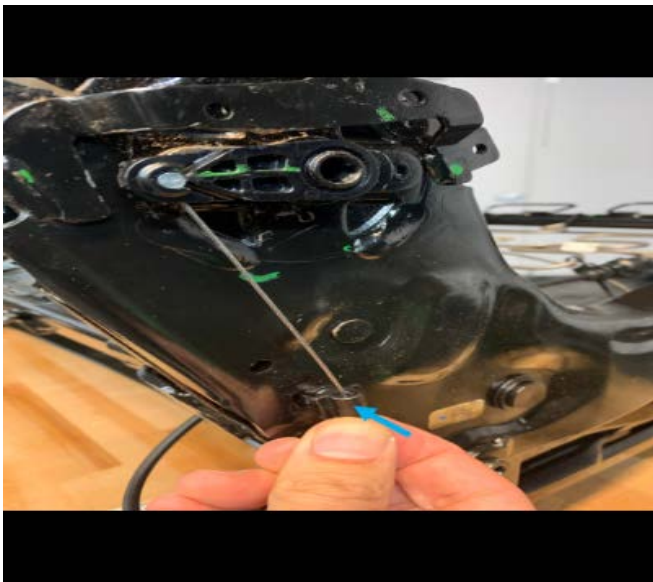

5932669

- 7.2. Pull fitting down and attach in keyhole in bracket.
- 7.3. Push fitting into bracket to make sure snap fingers engage.
- 7.4. Pull outboard to make sure fitting is fully attached to bracket and does not come out.

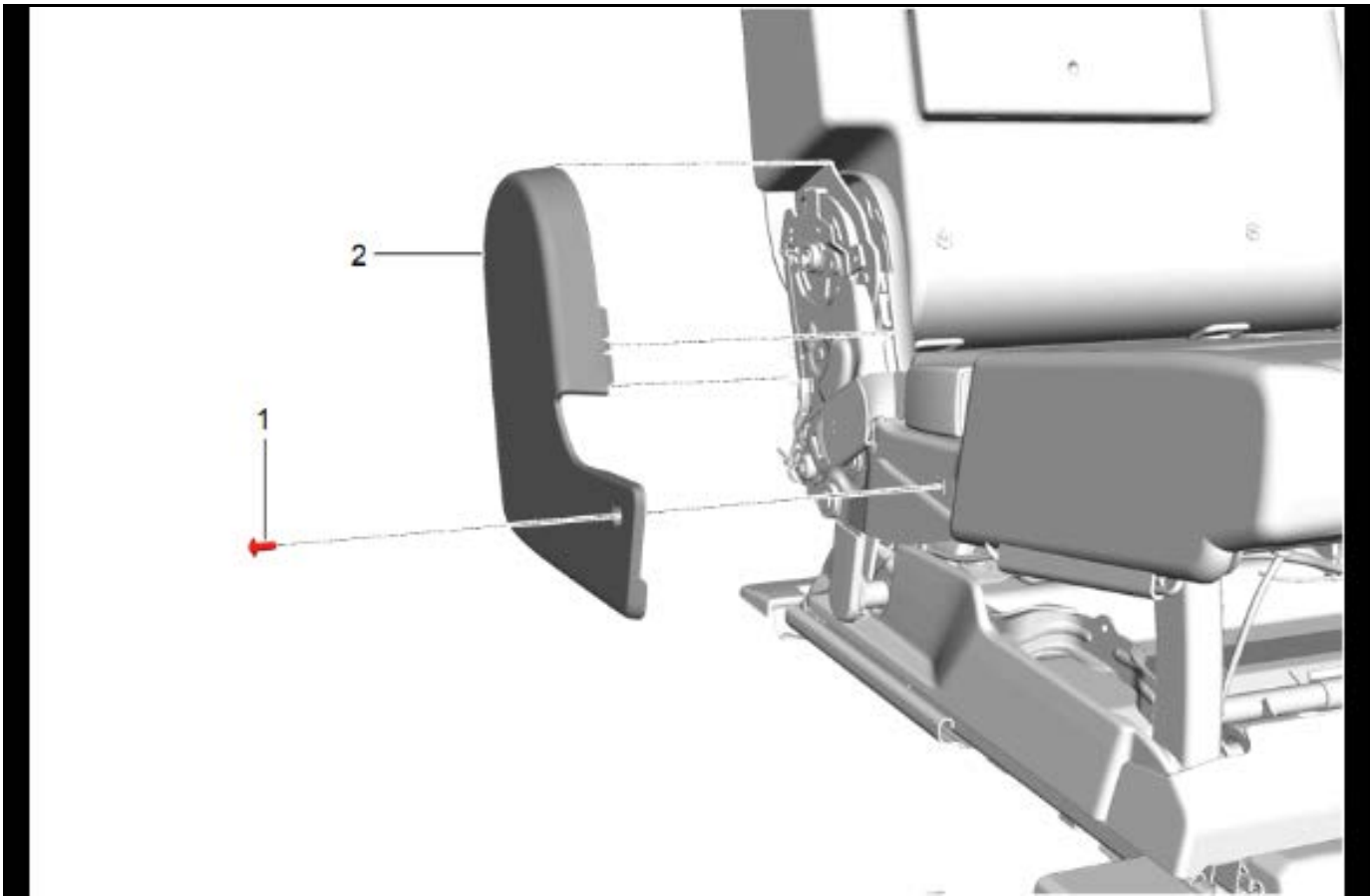

5608391

- 8. Reinstall the inboard rear seat hinge finish cover. Refer to *Rear Seat Hinge Finish Cover Replacement - Inboard (Bench)* in SI.
- 9. Locating reinforcement retainer:

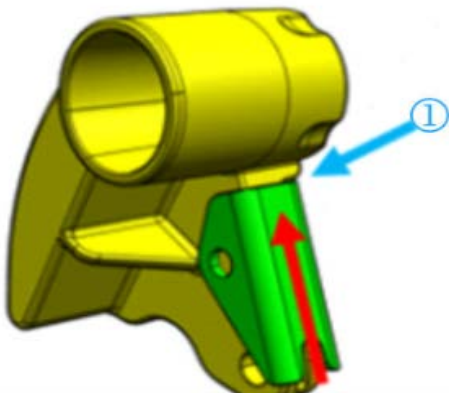

5932670

Note: Bottoming out the retainer against the edge of the white release lever (1) will get the retainer in the correct position.

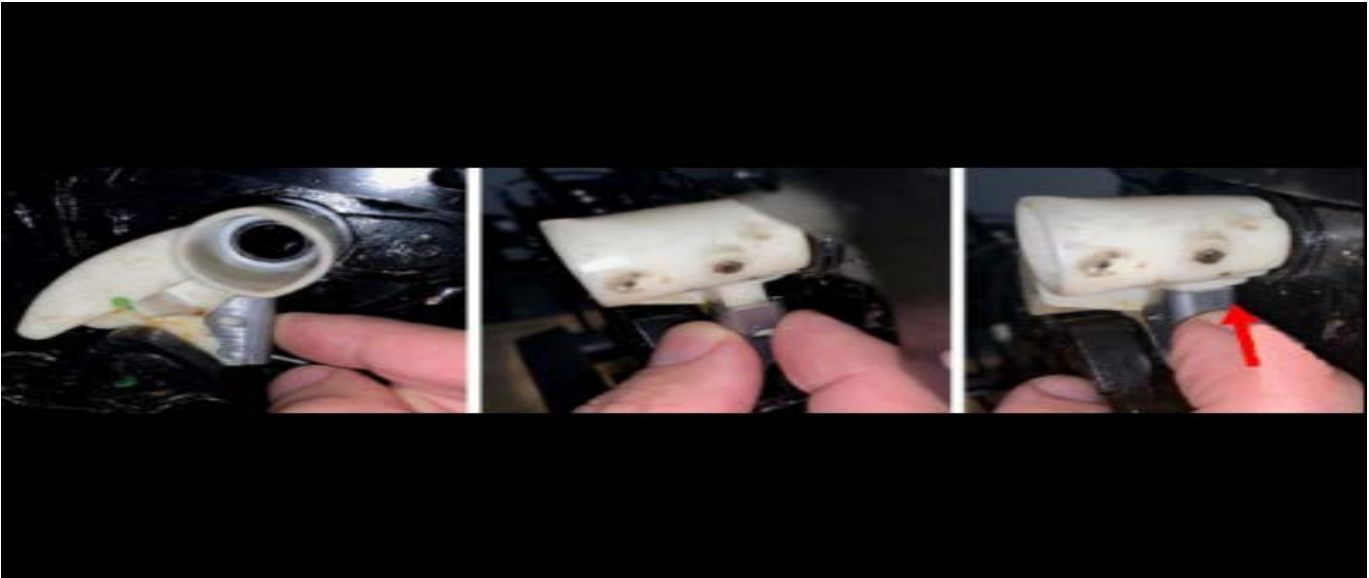

5932671

- 9.1. Place reinforcement retainer over white release lever.
- 9.2. Pushing the retainer UP to locate on edge of white release lever, .

10. Drill a hole in the white release lever:
 - 10.1. While holding retainer in up position, and using a 5/32 drill bit, drill a hole in the white release lever.



5932672



5932673

Note: Use the retainer as a template for proper location of the hole being drilled.

- 10.2. Remove any debris after drilling.



5932674

11. Attach retainer with rivet:

- 11.1. Insert 5/32 (4 mm) rivet from service kit fully into hole in retainer and then through white lever.



5932675

Note: Ensure rivet shank does not fall into seat mechanism.

- 11.2. Attach retainer to lever with pop rivet gun.
- 12. Verify correct installation and seat function:

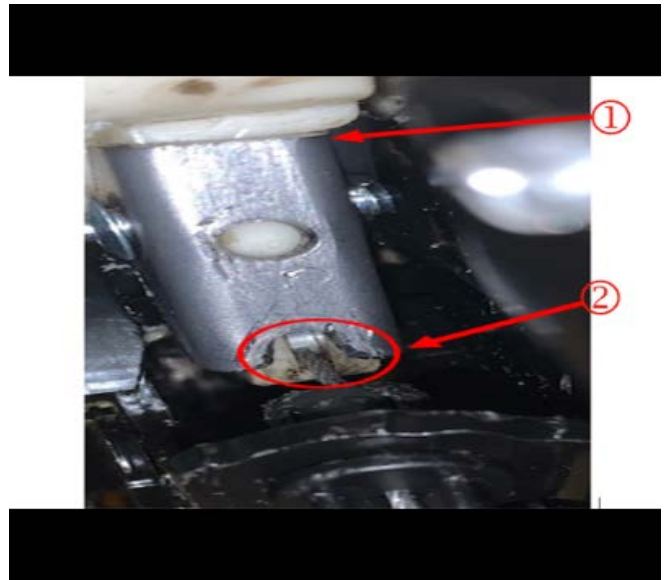

5932676

- 12.1. Retainer should bottom out at (1).
- 12.2. Verify edge of retainer is not contacting metal cable strand (2).

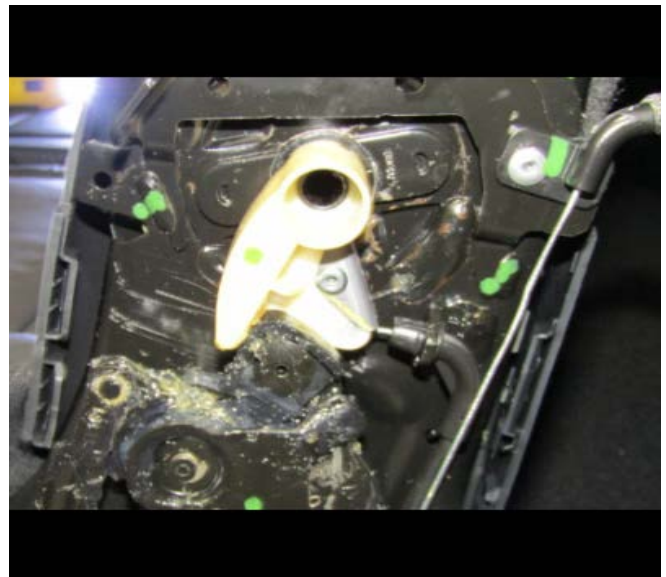

5932677

- 12.3. Verify seat folds several times after service retainer is added.

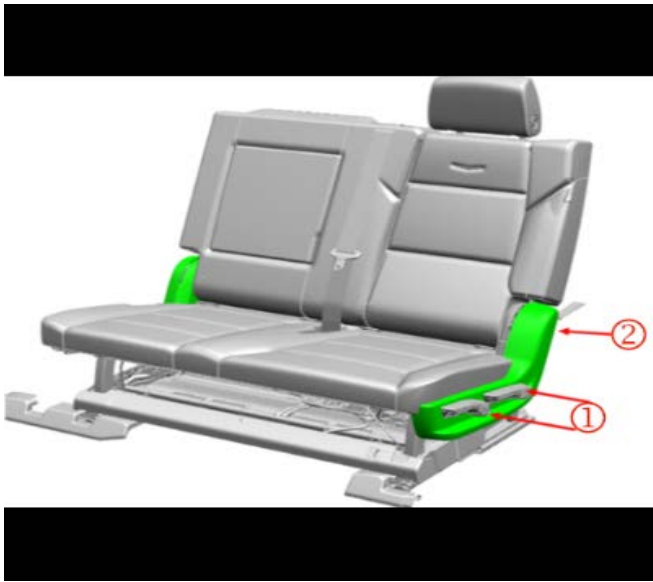

5932659

13. Reinstall the rear seat recliner outer finish cover (2) and the rear seat adjuster and recliner handles (1). Refer to *Rear Seat Hinge Finish Cover Replacement - Outboard*, in SI.

Parts Information

Causal Part	Description	Part Number	Qty
N/A	Reinforcement Retainer	86826430	1
	Rivet	23413599	1

Warranty Information

For vehicles repaired under the Bumper-to-Bumper coverage (Canada Base Warranty coverage), use the following labor operation. Reference the Applicable Warranties section of Investigate Vehicle History (IVH) for coverage information.

Labor Operation	Description	Labor Time
7086388*	Detach and Reattach 60 % Rear Seat Cable, Install Reinforcement Retainer	0.6 hr

*This is a unique Labor Operation for Bulletin use only.

Version	1
Modified	Released January 21, 2021

