



Technical Service Bulletin

40 Creaking noises from front of the vehicle when driving - Q7, Q8, A8

40 22 41 2058489/5 June 8, 2022. Supersedes Technical Service Bulletin Group 40 number 22-40 dated April 26, 2022, for reasons listed below.

Model(s)	Year	VIN Range	Vehicle-Specific Equipment
Q7	2017 – 2019	All	Not Applicable
A8	2019 – 2020	All	
Q8	2019	All	
A8 e quattro and S8	2020	All	
Q7 and SQ7	2020	000001 – 008523	
Q8, SQ8, and RS Q8	2020	000001 – 011971	

Condition

REVISION HISTORY		
Revision	Date	Purpose
5	-	Revised <i>Service</i> (Updated Procedure)
4	04/26/2022	Revised <i>header</i> (Updated Models)
3	08/17/2021	Revised <i>Warranty</i> (Updated Labor Operations)

Customer states:



Technical Service Bulletin

- They can hear squeaking, creaking, or similar noises from the front end when driving on uneven roads. The noises can possibly be heard and felt in the footwell or behind the dash panel.

Workshop findings:

The noises can be reproduced.

Technical Background

The noises can be generated on the lower-left guide in the area of the hydro-bushing. (Figure 1, Positions 7 and 8).

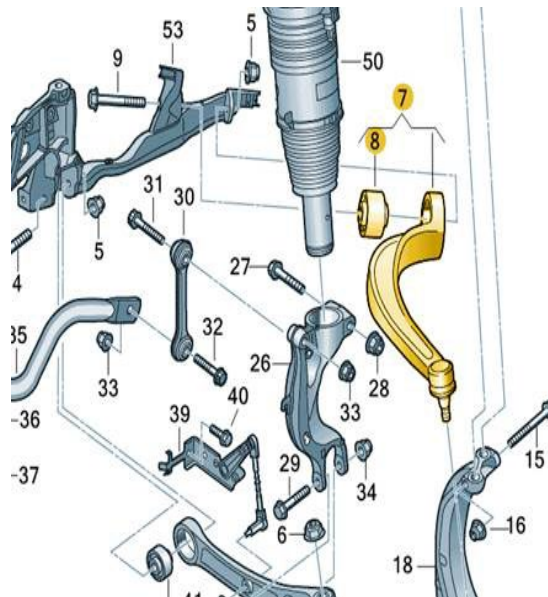

Figure 1. Hydro-bush.



Technical Service Bulletin

Parts such as the coupling rod (Figure 2, Position 30) are usually replaced by mistake, presenting no problems.

The noises from the guide link can be transmitted into the vehicle interior by the connection of the subframe on the body and are noticeable in the footwell.

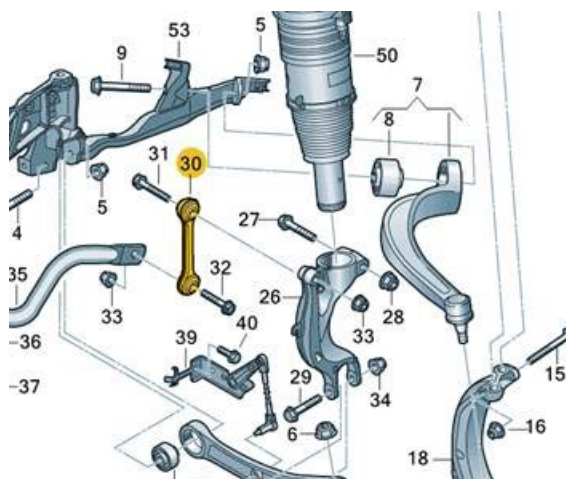

Figure 2. Coupling rod.

Production Solution

Required.

Service

1. Replace the hydro-bushing on the guide link in pairs (Figure 1, Position 8) according to the instructions in the ELSA Repair Manual at *Chassis >> Suspension >> Wheels, Steering >> 40 Front Axles >> Lower Control Arm and Ball Joint >> Guide link bonder rubber bushing, Removing and Installing*.
2. If repeat repairs are necessary and the hydro-bushing has already been replaced (pressed out/in), the complete guide link has to be replaced (Figure 1, Position 7). Refer to the instructions in the ELSA Repair Manual at *Chassis >> Suspension >> Wheels, Steering >> 40 Front Axles >> Lower Control Arm and Ball Joint >> Guide link, Removing and Installing*.



Tip:



Technical Service Bulletin

- Please precisely locate the source of the noise with acoustic testers.
- Check the repair history for repeat repairs.

Warranty

Claim Type:	<ul style="list-style-type: none">• 110 up to 48 months/50,000 miles.• G10 for CPO Covered vehicles – Verified Owner.• If the vehicle is outside any warranty, this Technical Bulletin is informational only.		
Service Number:	4012		
Damage Code:	0020		
	2 Lower guide links remove + reinstall	4016 2050	See SRT with associated operations
	Replace 2 guide link mounting	4012 5650	See SRT with associated operations
Diagnostic Time:	GFF	No allowance	0 TU
	Road test prior to the service procedure	0121 0002	10 TU
	Road test after the service procedure	0121 0004	10 TU
Claim Comment:	As per TSB 2058489/5		

All warranty claims submitted for payment must be in accordance with the *Audi Warranty Policies and Procedures Manual*. Claims are subject to review or audit by Audi Warranty.



Technical Service Bulletin

Required Parts and Tools

Always check with your Parts Department and/or ETKA for the latest information and parts bulletins.		
Part Number	Part Description	Quantity
4M0407183B	Hydro-Bushing	02
See ETKA	Guide Link (only if Hydro-Bushing has been replaced previously)	02
See ETKA	Fasteners, Bolts, Nuts, and Screws as needed per the Repair Manual	See ETKA/ELSA

Additional Information

All parts and service references provided in this TSB (**2058489**) are subject to change and/or removal.

©2022 Audi of America, Inc. All rights reserved. The information contained in this document is based on the latest information available at the time of printing and is subject to the copyright and other intellectual property rights of Audi of America, Inc., its affiliated companies, and its licensors. All rights are reserved to make changes at any time without notice. No part of this document may be reproduced, stored in a retrieval system, or transmitted in any form or by any means, electronic, mechanical, photocopying, recording, or otherwise, nor may these materials be modified or reposted to other sites without the prior expressed written permission of the publisher.