



DEF Level (UQLS) Sensor Troubleshooting Guide - US17+OBD16 Emissions and Newer



> Internal Content

Overview

The Urea Quality Level Sensor (UQLS) is a smart sensor that is located in the top of the Urea (DEF) Tank, commonly referred to as the DEF Level Sensor or Combined Tank Unit. This smart sensor has Urea Quality, Level, and Temperature all integrated into it as one unit and reports on the DL7 (J1939-7) Datalink. This sensor is responsible for sending all the urea information to the Aftertreatment Control Module (ACM) and Engine Control Module (ECM).

Diagnosis and Repair

Perform a DTC Readout and Review Codes

If any of the codes in yellow below appear on the Readout in Active or Confirmed status: Continue to the diagnostic steps in the following section.

DTC	DTC Description
P205B64	Reductant Tank Temperature Sensor, Circuit Range/Performance
P203A13	Reductant Level Sensor "A", Open Circuit
P203C00	Aftertreatment Reagent Level, Short Circuit Low
P206A13	Reductant Quality Sensor, Open Circuit
P206C00	Reductant Quality Sensor, Short Circuit Low
P206B64	Reductant Quality Sensor Range/Performance
P205A13	Reductant Tank Temperature Sensor, Open Circuit
P205C00	Aftertreatment Reagent Tank Temperature, Short Circuit Low

DO NOT REPLACE the DEF Level Sensor for any of the codes

in green below: DO NOT proceed with the diagnostics steps in this solution. None of these codes immediately indicate a failed DEF Level Sensor. Use the table in conjunction with PTT's Guided Diagnostics to find the root cause.



DTC Description	Probable Source
Reductant Level	Commonly low DEF quantity or

	Reductant Level	Commonly low DEF quality or
P203F00	Low	level sensor float in DEF tank stuck
P203B00	Aftertreatment Reagent Level Warning	System fault. Follow Guided Diagnostics.
U02A200	Lost Communication with Reductant Quality Module	Commonly a wiring harness or connection issue.
P24FF00	Reductant Temperature Too High	DEF tank temp above 70°C (160°F). Commonly the coolant lines to the DEF tank are swapped.
P207F00	Reductant Quality	DEF quality low and SCR efficiency low. Commonly a DEF quality issue.

Diagnostic Steps For Yellow Codes

1. Check the sensor wiring harness connection.

- Disconnect the harness and make sure there is no damage to the wires or pins, corrosion, or water ingress in either of the connectors. If damage is found replace in accordance with Technical Service Bulletin 258-040 - Aftertreatment Diesel Exhaust Fluid (DEF) Tank, Level Sensor, Replacement. Located in Impact.

1. Navigate to the Service tab.

2. In the Info Type box, make sure Technical Service Bulletins is selected.

3. In the Additional search values box select Keyword

4. Enter [258-040](#) into the text entry box, press the Search button.

5. A link for the article will be shown in the results. Click on the title, then choose one of the options from the window that opens.



2. Verify the DEF quality is at an acceptable value.

- Use refractometer part number 88890105 to verify the DEF quality. See illustration below.

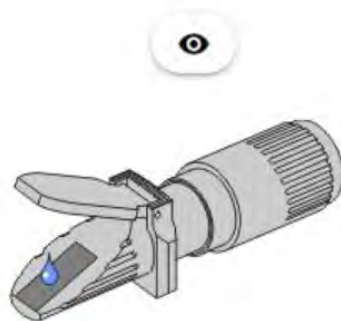
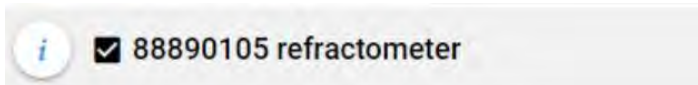

3. Verify that the DEF tank is not frozen.

4. Ensure that the DEF tank is adequately filled.

5. Clear the Fault Codes.

Live UI t the engine. Run the engine on high idle for 2 minutes at 1000 rpm or higher.

- 7. Turn the Engine Off, Key Off for 15 seconds.
- 8. Start the engine. Run the engine on high idle for 2 minutes a second time.

Evaluate the Results

If any of the faults shown in the yellow chart above return active:
 Replace the DEF Level Sensor in accordance with Impact instructions and the wires routed as shown in Technical Service Bulletin 258-040.

If none of the faults in the yellow chart above return: No troubleshooting or replacement of the DEF Level Sensor is necessary.

Rules for Replacement

- Warranty will only cover replacement of the UQLS if one of the codes in Yellow section above is present. If the UQLS is suspected to have failed with no codes present, an eService case is required for further evaluation.
- Standard Diagnostic Time for a DEF Level Sensor is 0.6 hrs.

Review the applicable video link below.

MACK	DEF LEVEL SENSOR
VOLVO	DEF LEVEL SENSOR

[mack](#) [volvo](#) [p205b64](#) [def level sensor](#) [uqls](#)

[def quality](#) [p206b64](#) [u02a200](#) [p203a13](#)

[p206c00](#) [p203b00](#) [p24ff00](#) [p207f00](#)

[p203c00](#) [p206a13](#) [p205a13](#) [p205c00](#)

[p203f00](#) [unlocking uptime](#)

Related links and attachments

[FSB 258-040](#)



Feedback

[Give feedback](#)

to help improve the content of this article

25068-9 FSB 258-040, Aftertreatment Diesel Exhaust Fluid (DEF) Tank, Level Sensor, Replacement

(May 2021)

On certain Volvo Truck models built before October 21, 2019, equipped with Diesel Exhaust Fluid (DEF) tank, the vehicle may experience water intrusion into the level sensor protection tubing. This may be due, in part, to kinking of electrical routing protective tubes. The solution is to replace the existing level sensor assembly with new level sensor assembly and follow improved electrical routing.

For removal and replacement of the DEF Tank, Level Sensor Follow Impact Operation 2589-03-02-05. During Installation follow electrical routing and clipping guide lines contained in the service bulletin per vehicle configuration.

Required parts			
Description		Old part	New Part
Frame Rail-Mounted Tank	DEF tank, 70-liter Capacity	23045836	23539939
	DEF tank, 45-liter Capacity	23045833	23539937
	DEF tank, 70-liter Capacity (Cummins Only)	23045847	23634011
Combination Mounted Tank	DEF tank 25/33-Liter Capacity	23045822	23539923
	DEF tank 25/33-Liter Capacity	23045830	23539935
	DEF tank 25-Liter Capacity (Cummins Only)	23045843	23634004

Frame-mounted DEF tank with Volvo engine

1. Maintain minimum 40 mm bend radius of UQLS (Urea Quality and Level Sensor) control module routing (A) at sensor head.

Note: Do not kink the UQLS control module routing.

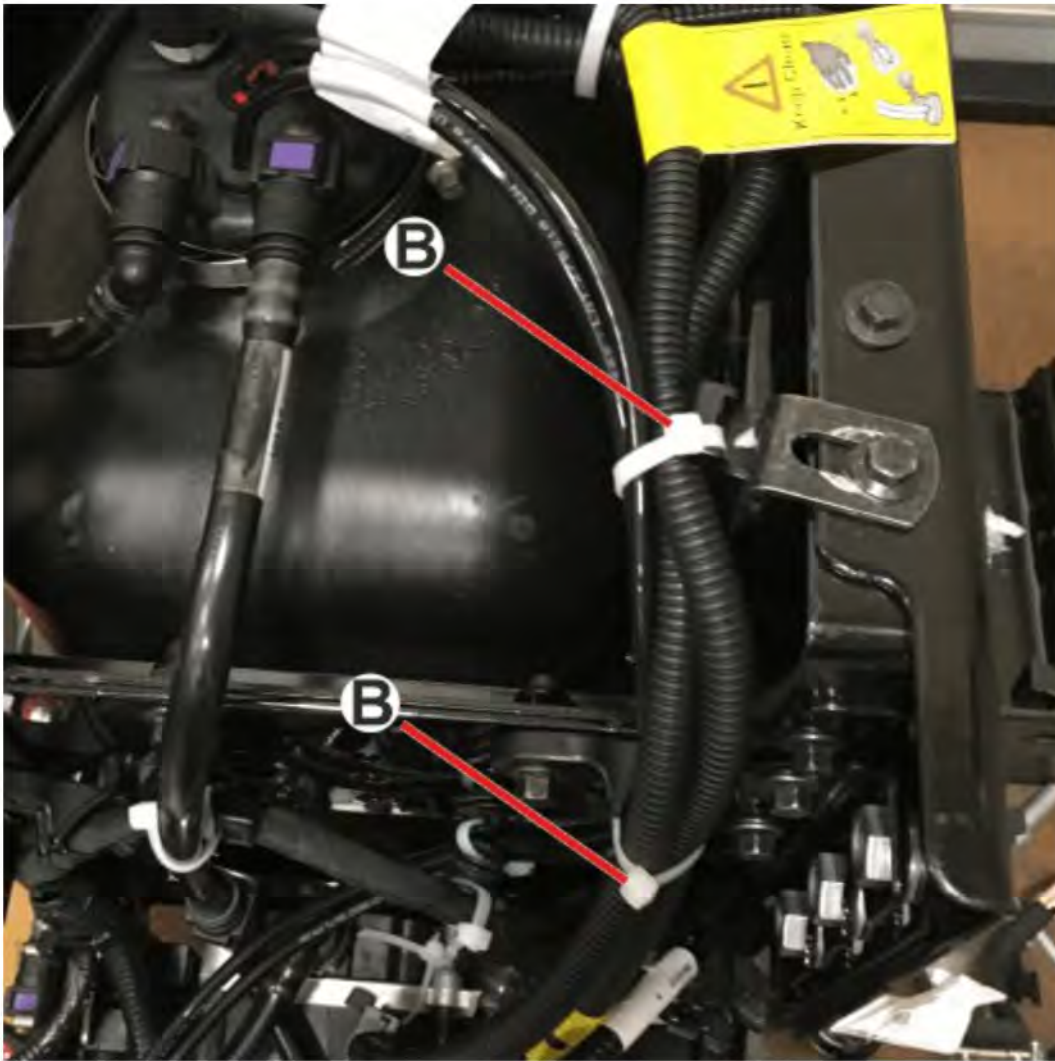

2. Route and tie the UQLS control module routing with the urea harness.

Note: Use regular cable tie (B).

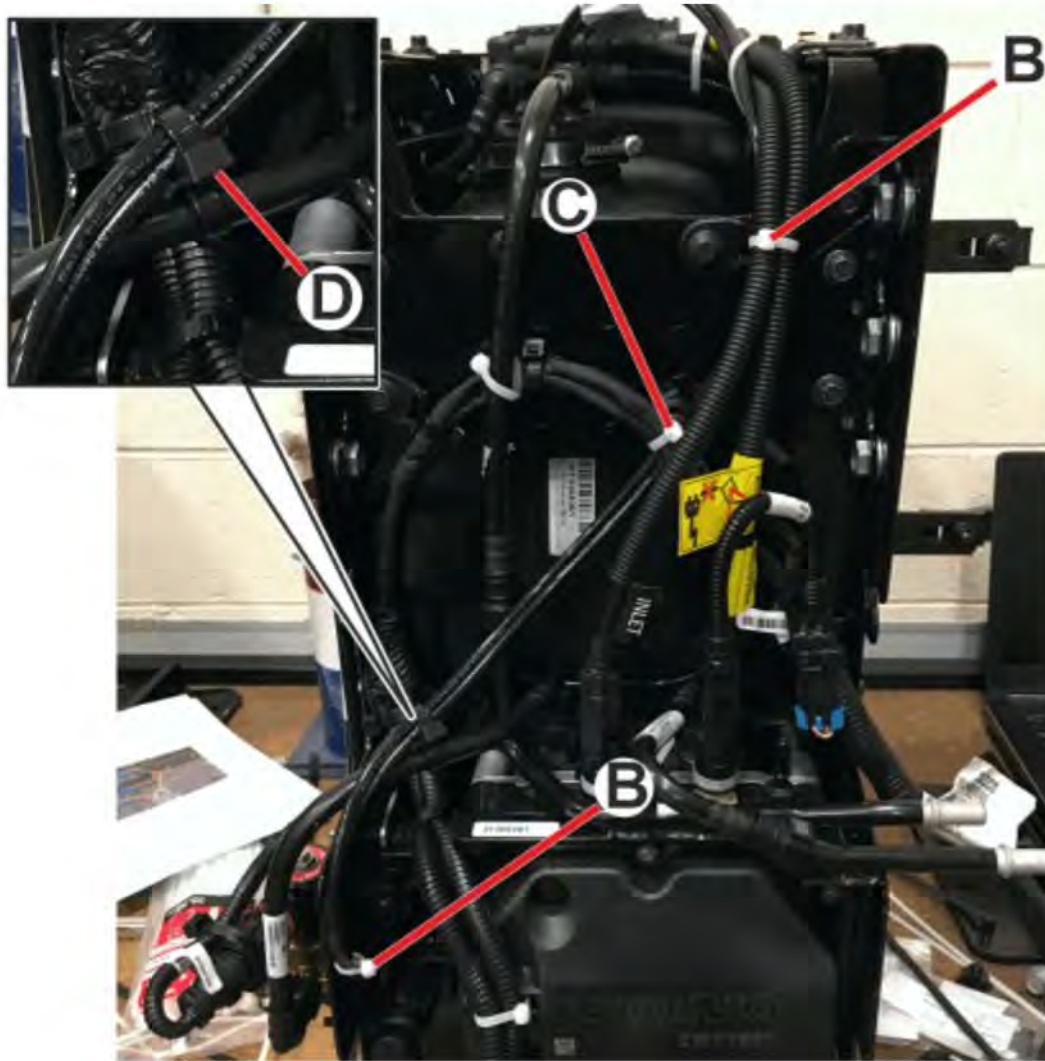

3. Route and tie the UQLS control module routing with the electrical harness.

Note: Use helicopter cable tie (C).

4. Route and tie UQLS control module routing with the coolant lines.

Note: Use double head cable tie (D).

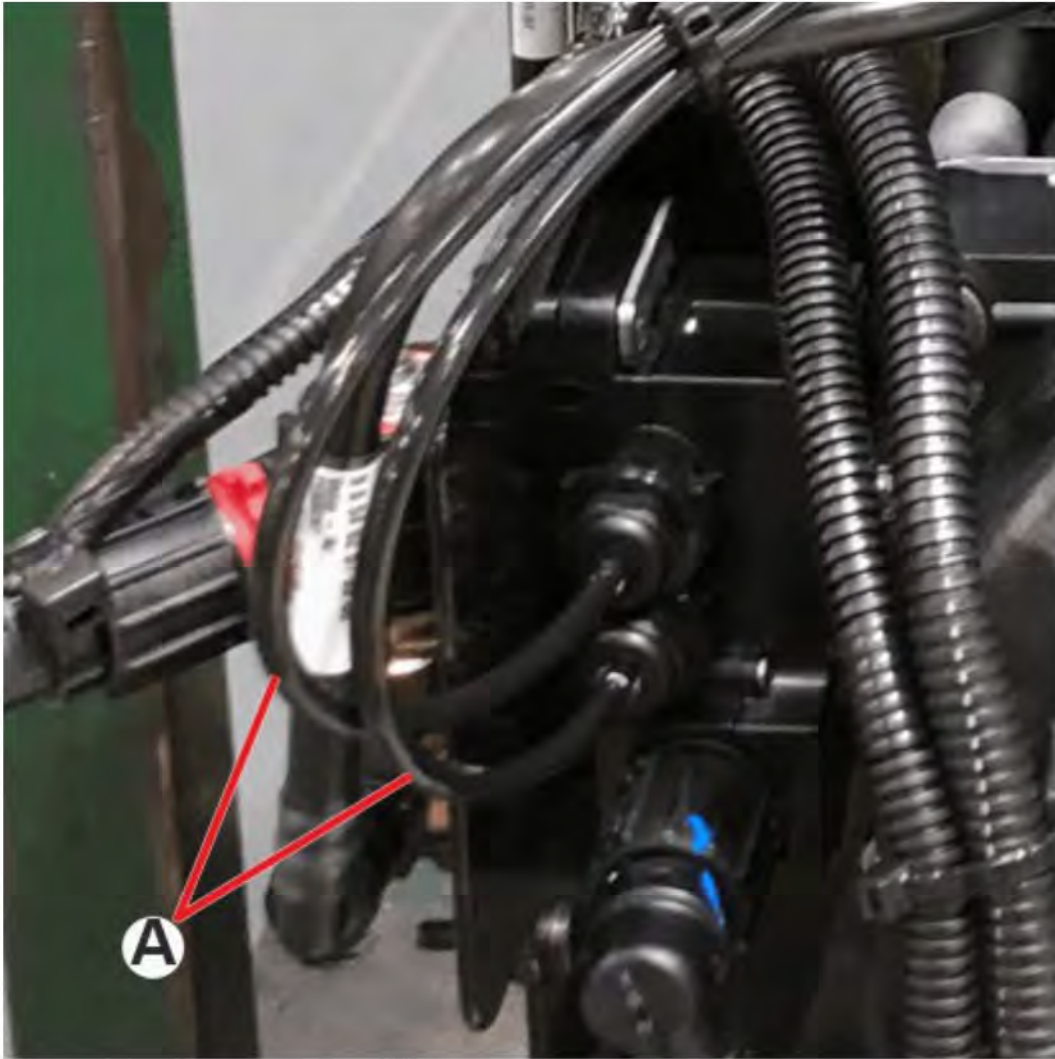

5. Maintain minimum 40 mm bend radius of UQLS control module routing(A) at electrical junction box.

Note: Do not kink the UQLS control module routing.

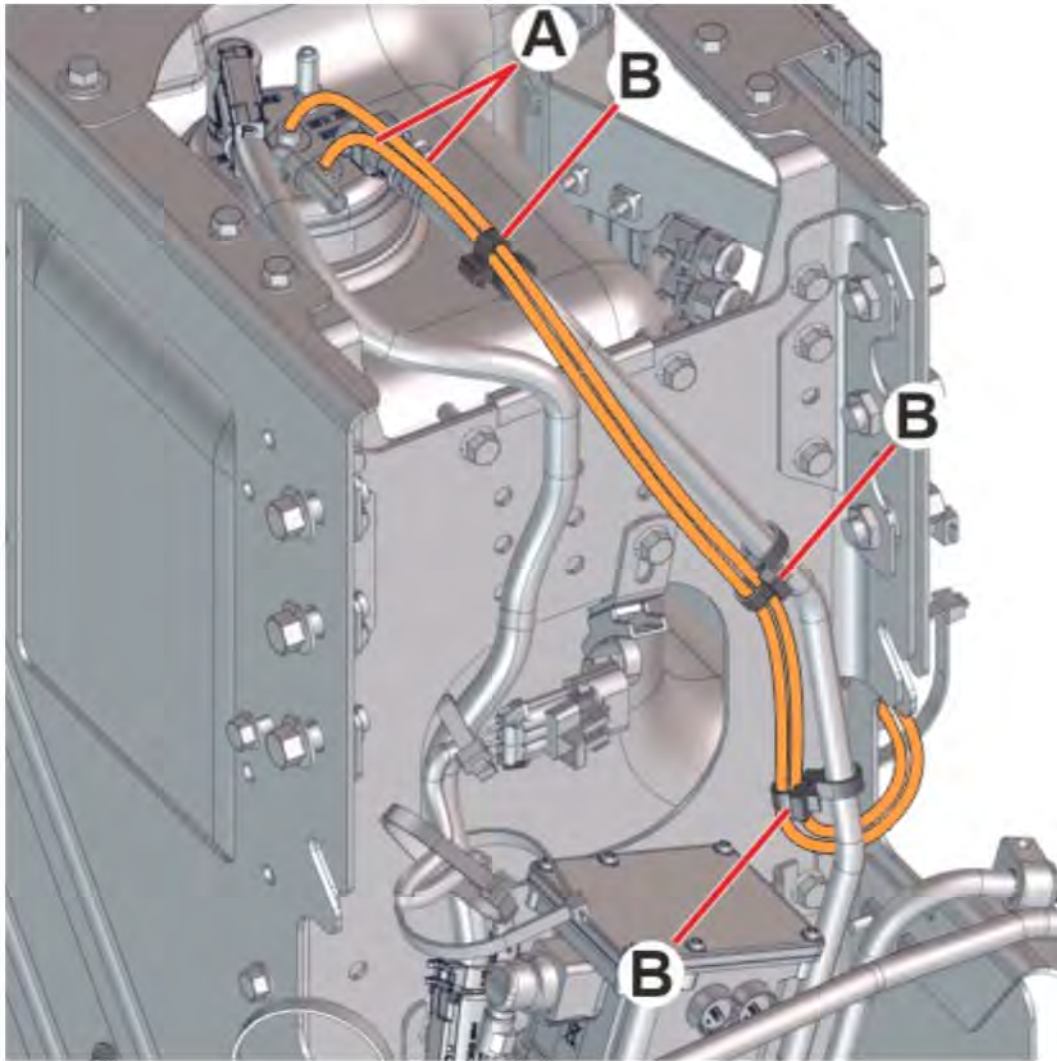

Frame-mounted DEF tank with Cummins engine

1. Maintain minimum 40 mm bend radius of UQLS (Urea Quality and Level Sensor) control module routing (A) at sensor head.

Note: Do not kink the UQLS control module routing.

2. Route and tie the UQLS (Urea Quality and Level Sensor) control module routing with the coolant pipe.

Note: Use double head tie (B).

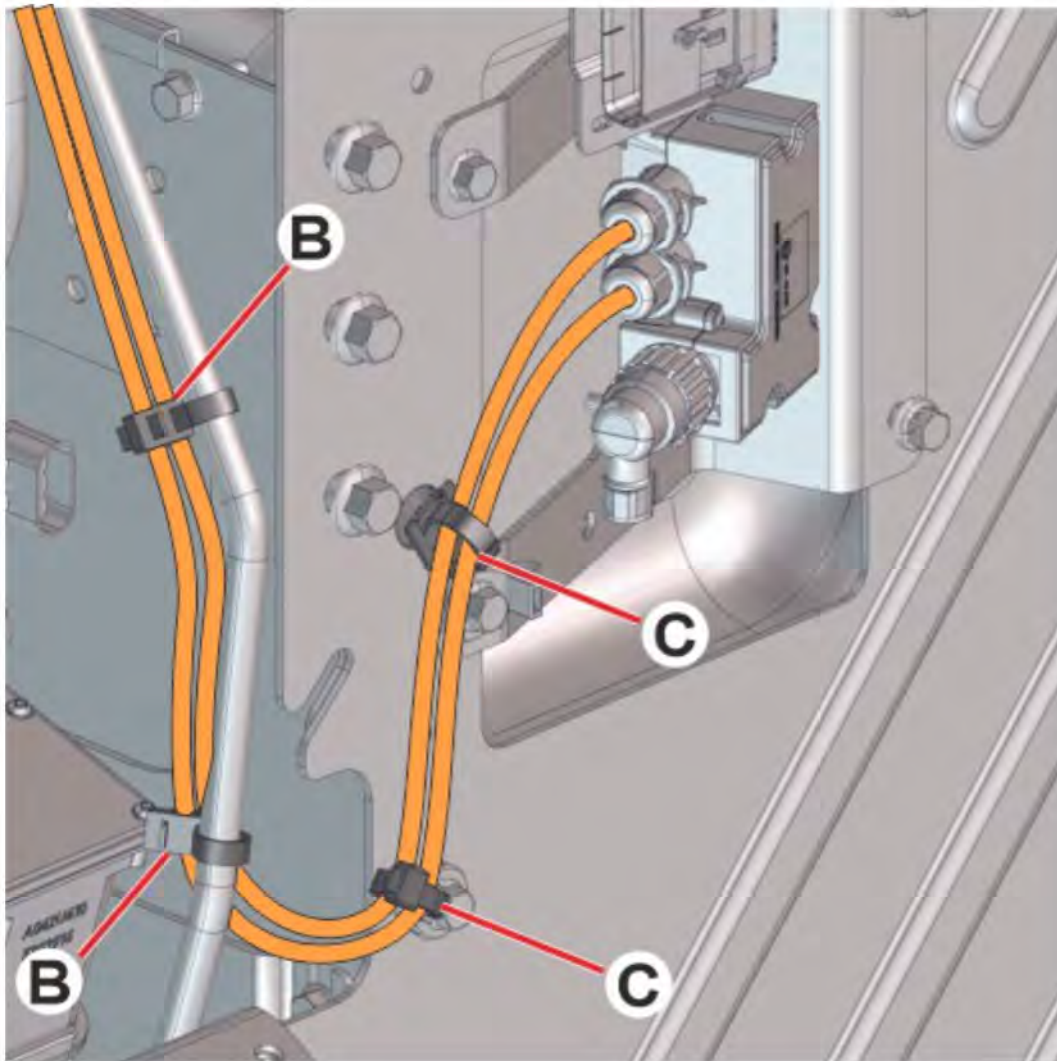

3. Route and tie the UQLS control module routing with the bracket.

Note: Use cable tie (C).

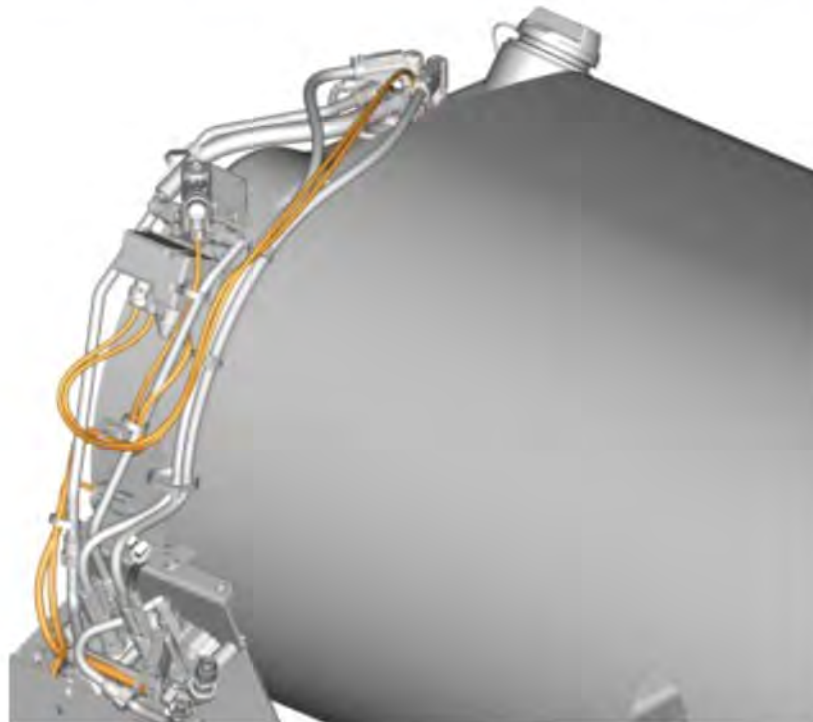
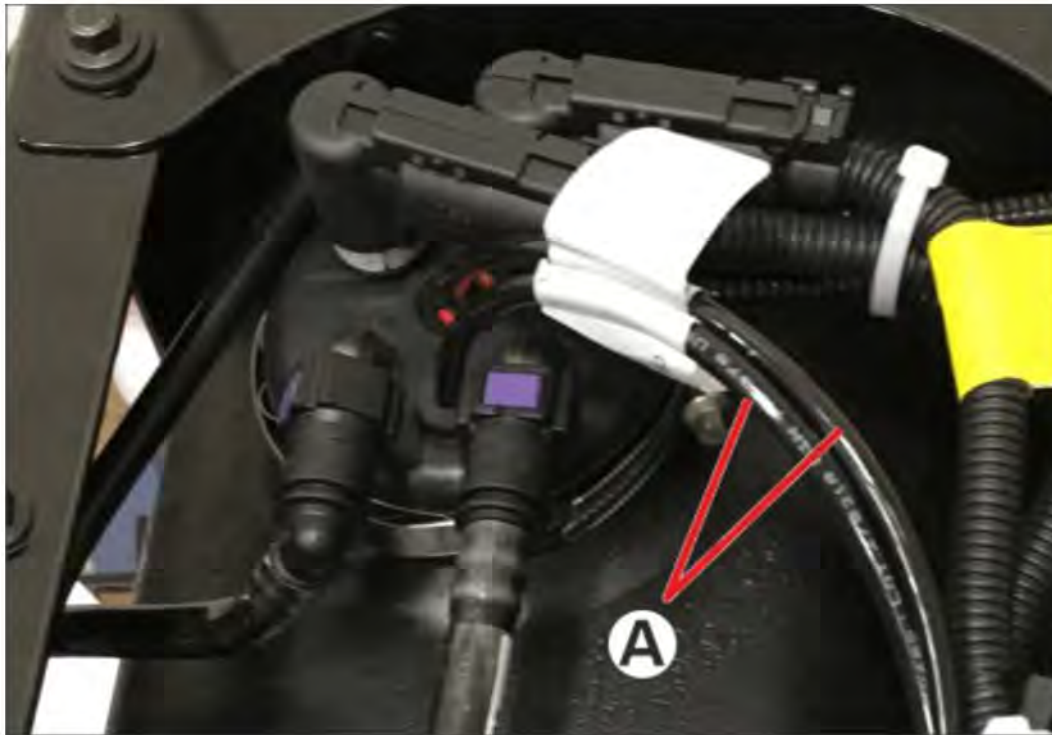

Reimbursement

This repair may be eligible for reimbursement if a product failure was experienced within time and mileage limits of the applicable Warranty coverage. Reimbursement is obtained via the normal claim handling process.

Claim Type (used only when uploading from the Dealer Bus. Sys.)	01
---	----

Labour Code	
Primary Labour Code Level sensor, tank, replace (includes harnesses routing)	2589-03-02-05 0.2 –2.0 hrs (Time varies per model)
Causal Part	23539939, 23045833, 23045847

VOLVO Trucks North America reserves the right to make any changes in design or to make additions to or upon its products without incurring any obligations to install the same on vehicles previously built.