

July 19, 2022

Version 12

Warranty Extension: MIL Comes On with DTCs P0301 Thru P0304

Supersedes 13-082, dated December 20, 2018, to revise the information highlighted in **yellow**.

AFFECTED VEHICLES

Year	Model	Trim	VIN Range
2009-13	Pilot	ALL	Check the iN VIN status for eligibility.

REVISION SUMMARY

Under **TOOL INFORMATION - REPAIR PROCEDURE B**, the part number was updated.

CORRECTIVE ACTION

2009-11 Models: Complete the diagnosis procedure and if necessary, update the PCM software and replace the affected spark plugs. If the vehicle returns after the updated PCM software and spark plug replacement have been installed, clean pistons and replace the piston rings along with the spark plugs (**Procedure B**).

NOTE:

- Make sure the software update has been completed, spark plugs replaced (Procedure A), and the vehicle returned to the customer before making any additional repairs. **Failure to do so will result in claim review by your DPSM and possible debit.**
- 2012-13 Models: Complete the diagnosis procedure and if necessary, clean the pistons and replace the piston rings along with the spark plugs (**Procedure B**).

BACKGROUND

American Honda is announcing a powertrain warranty extension as a result of a settlement of a class action captioned, *Soto et al. v. American Honda Motor Co., Inc.*, Case No. 3:12-cv-1377-SI (N.D. Cal.).

The piston rings on certain cylinders may rotate and align, which can lead to spark plug fouling. This can set DTCs P0301 No. 1 cylinder misfire detected, P0302 No. 2 cylinder misfire detected, P0303 No. 3 cylinder misfire detected, P0304 No. 4 cylinder misfire detected, and cause the MIL to come on.

American Honda is extending the powertrain warranty to cover repairs related to engine misfire (that triggers DTCs P0301 through P0304) to 8 years with unlimited mileage from the original date of purchase and has settled a class action based on this remedial measure.

This warranty extension does not apply to any vehicle that has ever been declared a total loss or sold for salvage by a financial institution or insurer, or has a branded or similar title under any state's law.

Additionally, the following videos are available to help with this bulletin:

- Tech2Tech [How to Clean Piston Ring Grooves](#)
- Tech2Tech [Let's Talk Spring Compressors](#)

CUSTOMER INFORMATION: The information in this bulletin is intended for use only by skilled technicians who have the proper tools, equipment, and training to correctly and safely maintain your vehicle. These procedures should not be attempted by "do-it-yourselfers," and you should not assume this bulletin applies to your vehicle, or that your vehicle has the condition described. To determine whether this information applies, contact an authorized Honda automobile dealer.

- Tech2Tech Cylinder Wall Inspection Tool

CUSTOMER NOTIFICATION

Owners of affected vehicles were sent a class action settlement notice regarding this warranty extension starting in October 2013.

Before doing work on a vehicle, verify its eligibility by doing an iN VIN status inquiry.

Refer customers seeking information about settlement benefits to www.enginemisfiresettlement.com, or instruct them to call **888-888-3082**.

DIAGNOSIS

1. Connect the HDS and check for the following DTCs: P0301 No. 1 Cylinder Misfire Detected, P0302 No. 2 Cylinder Misfire Detected, P0303 No. 3 Cylinder Misfire Detected, P0304 No. 4 Cylinder Misfire Detected.

Are any of these DTCs stored?

YES – Go to step 2.

NO – Stop. This bulletin does not apply. Continue with normal troubleshooting.

2. Remove and check the spark plug(s) on the affected cylinders (example: if P0301 is stored, check the spark plug on cylinder No. 1).

Are the spark plug(s) fouled?

YES – Proceed to Step 3.

NO – Stop. This bulletin does not apply. Continue with normal troubleshooting.

GOOD



NO GOOD



3. Check the PCM software version P/N located above the PGM FI Data List.

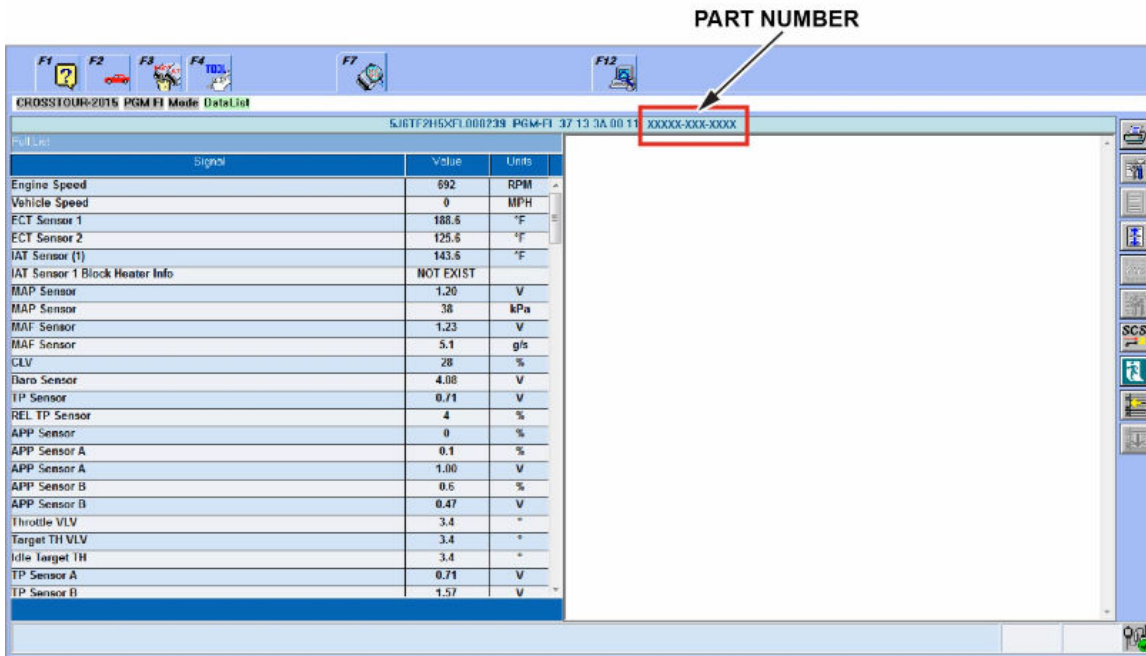

Year/Model	Program ID (or later)	Program P/N (or later)
2009–10 Pilot (2WD))	N0A570	37805-RN0-A57
2009–10 Pilot (4WD)	N0A570	37805-RN0-A77
2011 Pilot (2WD)	N0A630	37805-RN0-A63
2011 Pilot (4WD)	N0A830	37805-RN0-A83
2012–13 Pilot (ALL)	Software Updated from Factory	

Is the PCM Program ID and/or Program P/N the same or newer than what is listed above, 2009-11 model years only?

NO– The PCM software needs to be updated. Go to REPAIR PROCEDURE A.

YES – The correct software is installed. The piston rings on select cylinders need to be replaced. Go to step 4.

NOTICE

The PCM software must first be updated with the correct version, replace spark plugs and the vehicle returned to the customer. Piston cleaning and piston ring replacement, as described below, should only be done after the customer has returned with a second failure or if the vehicle's software is the correct version. **Failure to follow this process correctly may result in a full debit of the warranty claim to your dealer.**

4. Note which DTCs are stored in the vehicle.

Does the vehicle have DTC P0304 stored? (Any combination of DTCs P0301, P0302, P0303, P0304 may also be stored.)

YES – Go to REPAIR PROCEDURE B for the cylinders listed, Cylinders 1–4: Clean the pistons, replace the piston rings, and replace the spark plugs.

NO – Go to REPAIR PROCEDURE B for the cylinders listed below:

- Cylinder 1–3: Clean the pistons and replace the piston rings.
- Cylinder 1–4: Replace the spark plugs.

WARRANTY CLAIM INFORMATION

2009–11 Models: Confirm PCM Software is or has been updated with the correct version, spark plugs 1–4 have been replaced and the vehicle returned to the customer (**Procedure A**). Piston cleaning and piston ring replacement along with the spark plugs, should be only be done after the customer has returned with a second failure or if the vehicles software is the correct version (**Procedure B**). **Failure to follow this process correctly may result in a full debit of the warranty claim to your dealer.**

2012–13 Models: Are equipped with updated software from the factory, no software updated is needed. Piston cleaning and piston ring replacement along with the spark plugs should be done (**Procedure B**).

FLAT RATE NOTE: The procedure in this bulletin is different than the service manual. This procedure does not require the complete removal of the power steering pump, catalytic converter(s), engine and transmission, or the crankshaft. As a result, the operation number is unique and the FRT is reduced (**Procedure B**).

2009–11 Pilot

Operation Number	Description	Flat Rate Time	Defect Code	Symptom Code	Template ID	Failed Part Number
1171G9	2009–11 Pilot: Procedure A Update the PCM and replace spark plugs 1–4 (includes diagnosis).	0.5 hr	5V500	JC000	13-082A	13011–R70–A02
1171H0	2009–11 Pilot: Procedure B Replace piston rings 1–3 and replace spark plugs 1–4 (includes diagnosis).	9.1 hrs	5V500	JC000	13011–R70–A02	
1171H0B	2009–11 Pilot: Add if replacing piston rings on cylinder 4.	1.9 hrs	5V500	JC000	13011–R70–A02	

2012–13 Pilot

1171H0	2012–13 Pilot: Replace piston rings 1–3 and replace spark plugs 1–4 (includes diagnosis).	9.1 hrs	5V500	JC000	13011–5G0–A01	
1171H0B	2012–13 Pilot: Add if replacing piston rings on cylinder 4.	1.9 hrs	5V500	JC000	13011–5G0–A01	

Skill Level: Repair Technician

PARTS INFORMATION

NOTE: Do the DIAGNOSIS first to determine which cylinders you will need to repair.

PARTS INFORMATION A – SOFTWARE UPDATE AND CYLINDERS 1–4 SPARK PLUG REPLACEMENT

Part Name	Part Number	Quantity
Spark Plugs (2009–11 All)	12290-R70-A01	4
Spark plugs (2012–13 All)	12290-R71-L01	4

PARTS INFORMATION - PISTON CLEANING AND RING REPLACEMENT

Part Name	Part Number	Cyl 1-3	Cyl 1-4
Cyl. Gasket (Fr)	12251-R70-A01		1
Cyl. Gasket (Rr)	12261-R70-A01	1	1
Drain Washer 14 mm	94109-14000	1	1
EGR Pipe Gasket A	18716-R70-A01	1	1
EGR Pipe Gasket B	18719-R70-A01	1	1
Ex. Chamber Gasket	18115-R70-A01	1	2
Ex. Pipe Gasket	18212-SA7-003	2	2
Head Gasket Fr. (Valve Cover)	12030-R70-A00		1
Head Gasket Rr. (Valve Cover)	12050-R70-A00	1	1
In. Manifold Gasket (Intake Top Cover)	17146-R70-A01	1	1
In. Manifold Gasket (In. Manifold to Base) (2009–10 2WD)	17105-RCA-A01	1	1
In. Manifold Gasket (In. Manifold to Base) (2009–13 4WD & 2011–13 2WD)	17105-RCJ-A01	1	1
Oil Filter	15400-PLM-A02	1	1
O-ring (7.47 mm x 3.6 mm)	91301-PLC-000	2	2
O-ring (31.2 mm x 4.1 mm)	91314-PH7-003	2	2
Piston Ring Set	13011-R70-A12	3	4
Pre-chamber Gasket	18393-SDB-A00	1	1
Self-locking Nut (8 mm)	90212-RCA-A01	4	8
Self-locking Nut (10 mm)	90212-SA5-003	9	9
Spark Plug (2009–11 All)	12290-R70-A01	4	4
Spark plug (2012–13 All)	12290-R71-L01	4	4
Strainer O-ring	15221-RYE-A01	1	1
Timing Belt Bolt	14551-RCA-A01	1	1

Part Name	Part Number	Cyl 1-3	Cyl 1-4
Water Gasket Fr.	19411-P8A-A03	1	1
Water Gasket Rr.	19412-P8A-A02	1	1

Replace Parts as Needed for Repair Procedure B

Part Name	Part Number	Cyl 1-3	Cyl 1-4
Connecting Rod Bolt (may require up to 2 bolts per connecting rod)	13204-P8A-A01	6	8
Washer-Bolt (12 x 163) (may require up to 8 bolts per cylinder head)	90005-PAA-A01	8	16

REQUIRED MATERIALS - REPAIR PROCEDURE B

Material Description	Part Number	Quantity
Honda Long-Life Antifreeze/Coolant Type 2	0L999-9011	3 gallons
Full Synthetic Engine Oil 0W-20 Oil	08798-9063	6 quarts
Genuine Honda Motor Oil 5W-20 (If requested 2009-11)	08798-9032	6 quarts
Hondabond HT (1 Tube Repairs 5 Vehicles)	08718-0004	1 tube
Genuine Honda Throttle Plate Cleaner	08700-9204	
Nylon Parts Cleaning Brush	(commercially available)	
5/16 ID Flexible Hose	(commercially available)	

TOOL INFORMATION - REPAIR PROCEDURE B

Part Name	Part Number	Quantity
Piston Ring Groove Cleaner	07AAZ-TA5A100	1
Cylinder Wall Inspection Tool	07AAJR70A300	1
Gasket Remover/Pan Separator	LIL50190	1
Piston Ring Expander	Snap-On PRS8 or equivalent	1
Piston Ring Compressor	SCP1289 or equivalent	1

NOTE: Each dealer was sent one cylinder wall inspection tool.

REPAIR PROCEDURE A - SOFTWARE UPDATE AND CYLINDERS 1-4 SPARK PLUG REPLACEMENT

1. For 2009-11 models only, update the PCM software. Refer to Service Bulletin 01-023, *Updating Control Units/Modules*.
2. Replace spark plugs on cylinders 1-4, then return the vehicle to the customer.

REPAIR PROCEDURE B - PISTON CLEANING AND RING REPLACEMENT

2009–11 Models: Confirm PCM software is or has been updated with the correct version, spark plugs 1–4 have been replaced and the vehicle returned to the customer (**Procedure A**). Piston cleaning and piston ring replacement along with the spark plugs should only be done after the customer has returned with a second failure or if the vehicle's software is the correct version (**Procedure B**). **Failure to follow this process correctly may result in a full debit of the warranty claim to your dealer.**

2012–13 Models: Are equipped with the updated software from the factory, no software update is needed. Piston cleaning and piston ring replacement along with the spark plugs should only be done after the diagnosis of the spark plugs has concluded that (**Procedure B**) is required.

The following service information procedures have been used in full or in part within this service bulletin. For more detail on these procedures, and torque specifications for some components, refer to the service information.

- Battery Terminal Disconnection and Reconnection
- Fuel Pressure Relieving
- Fuel Line/Quick-Connect Fitting Removal
- Air Cleaner Removal/Installation
- Splash Shield Replacement
- Drive Belt Removal/Installation
- Engine Oil Replacement
- Coolant Replacement
- Hydraulic Power Steering Fluid Check/Replacement
- Intake Manifold Removal and Installation
- Timing Belt Removal and Installation
- Warm Up-TWC Removal/Installation
- Cylinder Head Cover Removal
- Cylinder Head Removal and Installation
- Piston Ring Replacement
- PCM Idle Learn Procedure
- Valve Adjustment

Piston Removal Procedure

- Use fender covers to avoid damaging painted surfaces.
- To avoid damaging any wires and terminals, unplug the circuit connectors carefully while holding the connector portion.
- Mark all the circuits and hoses to avoid misconnection. Make sure they do not contact other circuit wiring, hoses, or interfere with other parts.

1. Relieve the fuel pressure.
2. Remove both front wheels so you can fully lower the vehicle.
3. Do the battery removal procedure.
4. Disconnect the fuel feed hose line at the bulkhead.

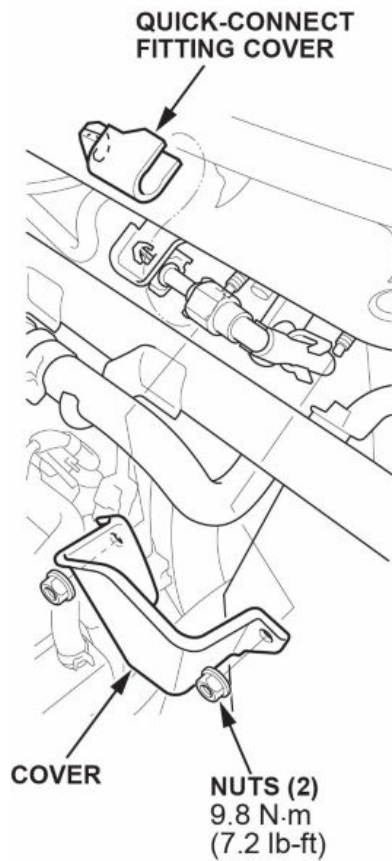

5. Remove the engine cover.

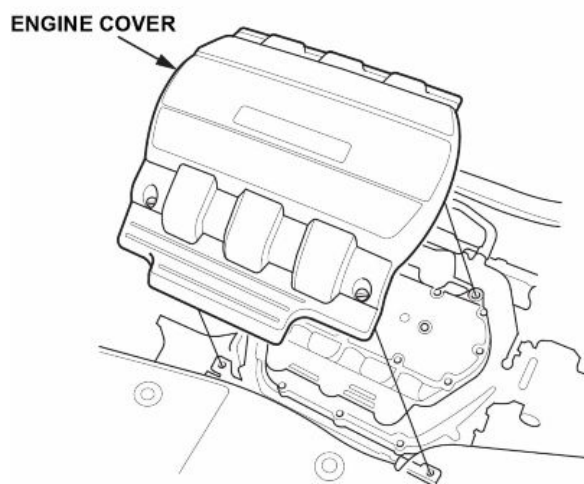

6. Remove the radiator cap.
7. Raise the vehicle.

8. Remove the front splash shield.

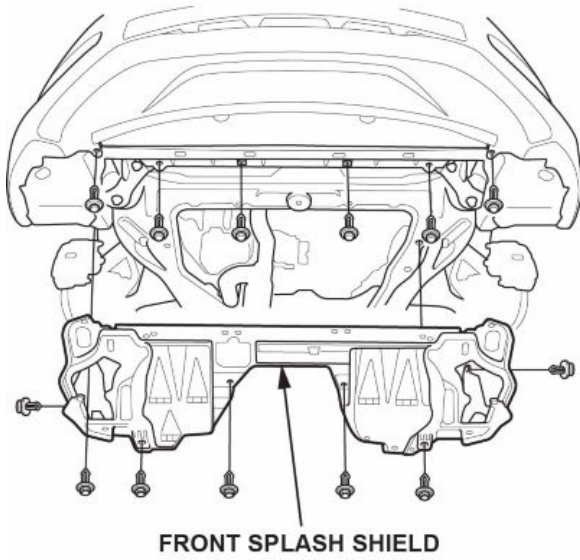

9. Drain the engine oil.
10. Loosen the drain plug on the radiator, and drain the coolant.

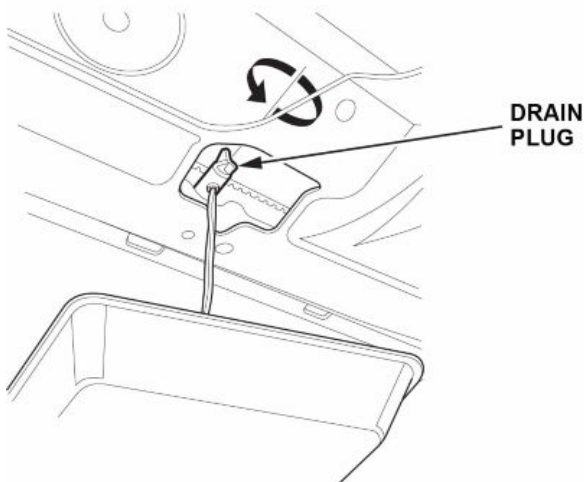

11. Install a 5/16th inner diameter rubber hose on the drain bolt located at the rear of the engine block, loosen the drain bolt, and drain all remaining coolant. Then disconnect the oil pressure switch connector.

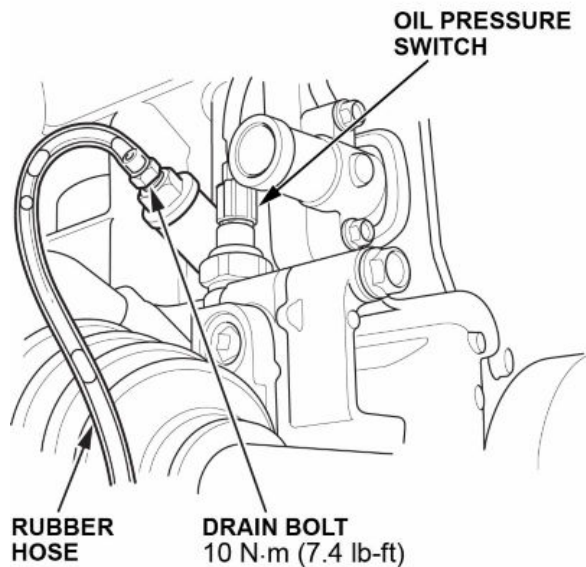

12. Remove the subframe stiffener.

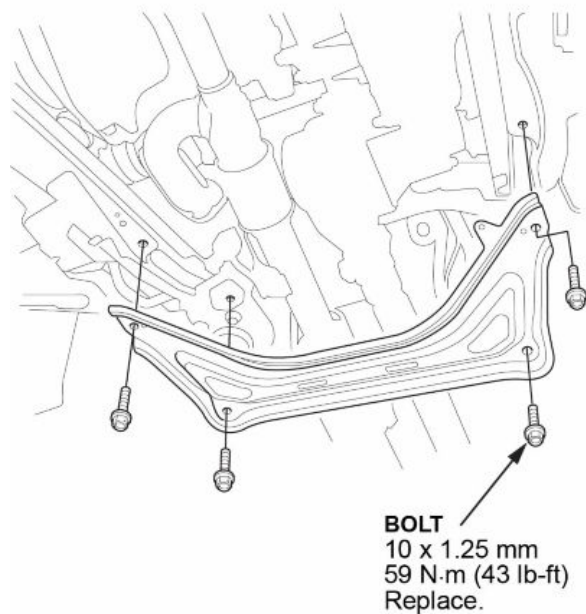

13. Remove exhaust pipe A.

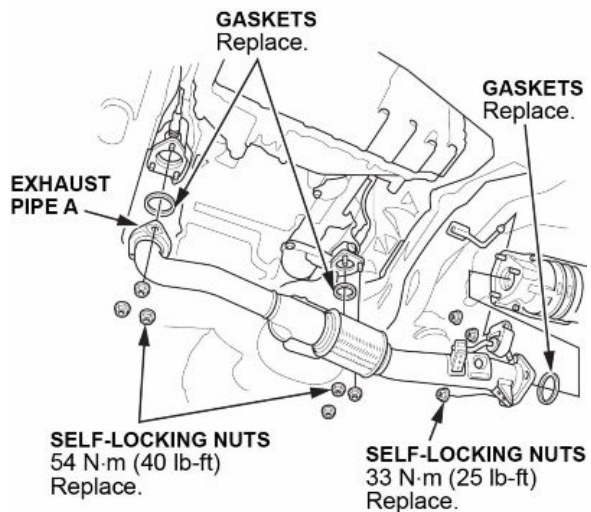

14. Depending on the diagnosis, remove the appropriate WU-TWC support bracket bolts.

15. Remove the EGR lower pipe nuts.

16. Remove the crankshaft pulley bolt but not the pulley.

NOTE: Make sure to apply new oil to the bolt flange and threads before reinstallation.

X : Remove any oil

O : Clean

● : Lubricate with new engine oil

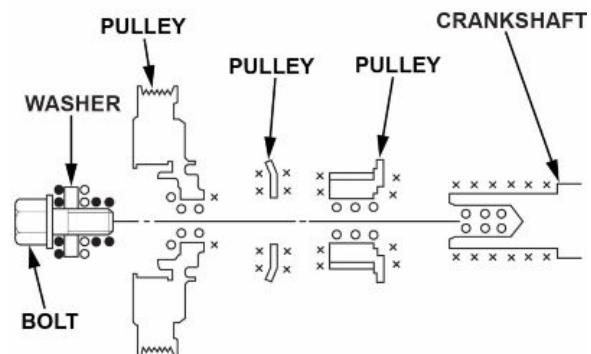

17. Lower the vehicle.

18. Disconnect the MAP sensor connector and the breather pipe, then remove the intake air duct.

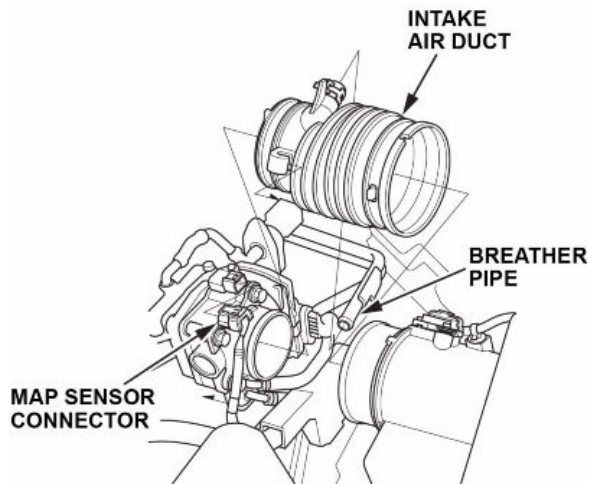

19. Disconnect the throttle body connector, the EVAP canister purge valve connector, the EVAP hose, the brake booster vacuum hose, and the vacuum hose.

20. Disconnect and plug the water bypass hoses.

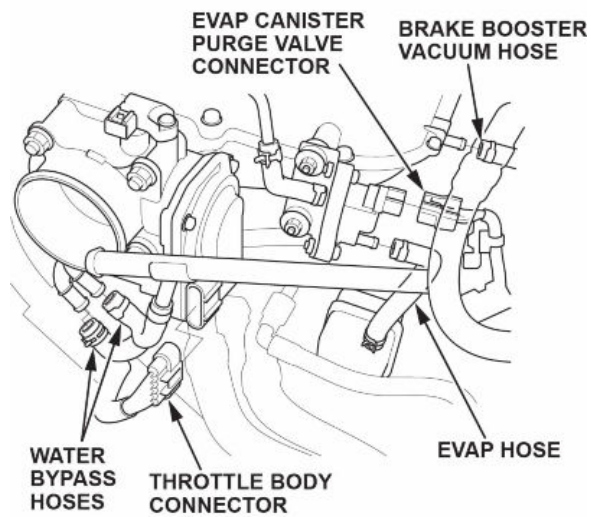

21. Remove the drive belt.
 22. Remove the drive belt auto-tensioner.
 23. Remove the power steering pump bolts, the power steering bracket then secure the power steering pump out of the way.
- NOTE: Do not remove any of the hoses.

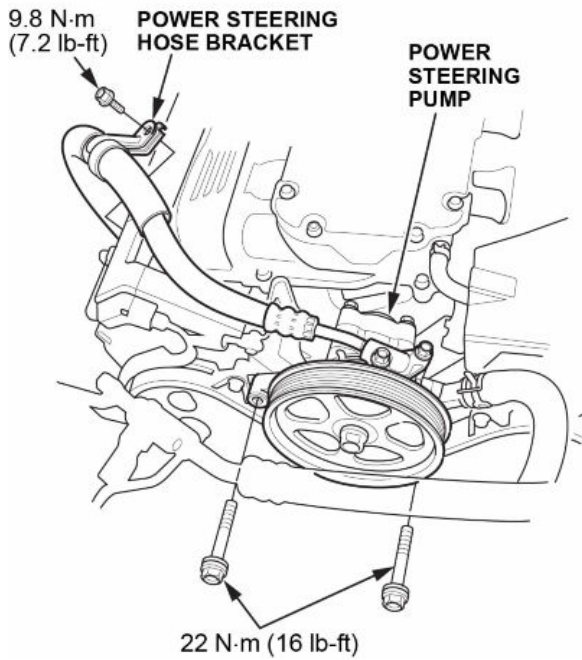

24. Remove the engine harness holder bolt on the side engine mount.
25. Set the engine to TDC cylinder one.
26. Remove the crankshaft pulley.
27. Remove the timing belt.
28. Remove the timing belt idler pulley.
29. Remove the engine intake upper cover and PCV hose.

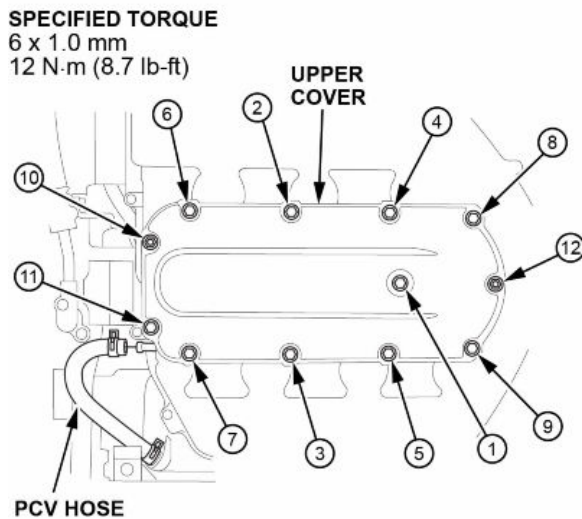

30. Remove the intake manifold bolts and nuts in three steps, then remove the intake manifold.

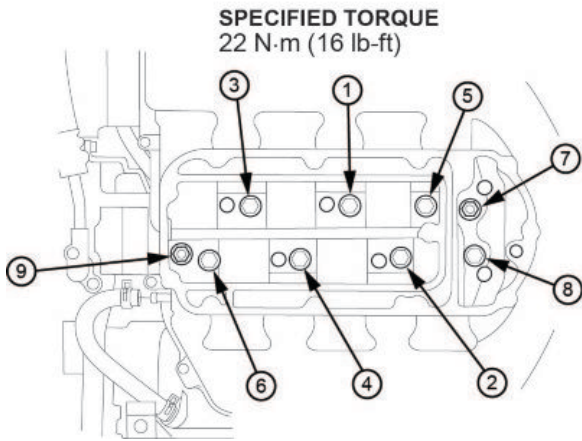

31. Remove the PCM cover.

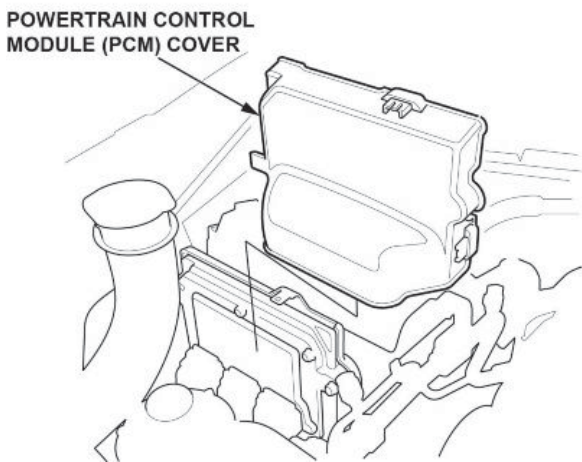

32. Remove the PCM connectors and harness clamps. Remove the battery cables from the underhood fuse box.

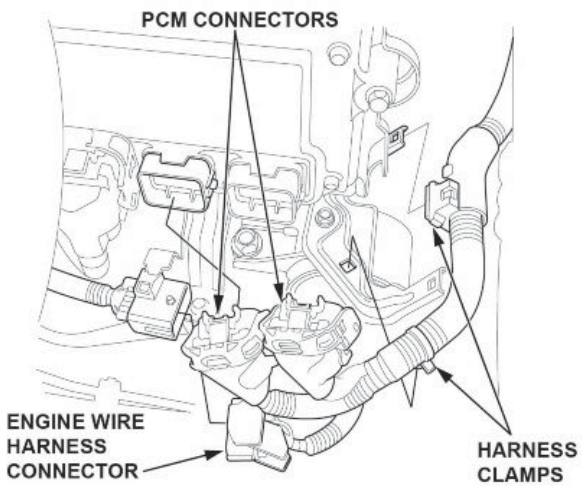

33. Remove the appropriate Ignition coils based on the diagnosis.

NOTE: Depending on the diagnosis, you will either have to remove the rear bank ignition coils or both the front and rear bank ignition coils.

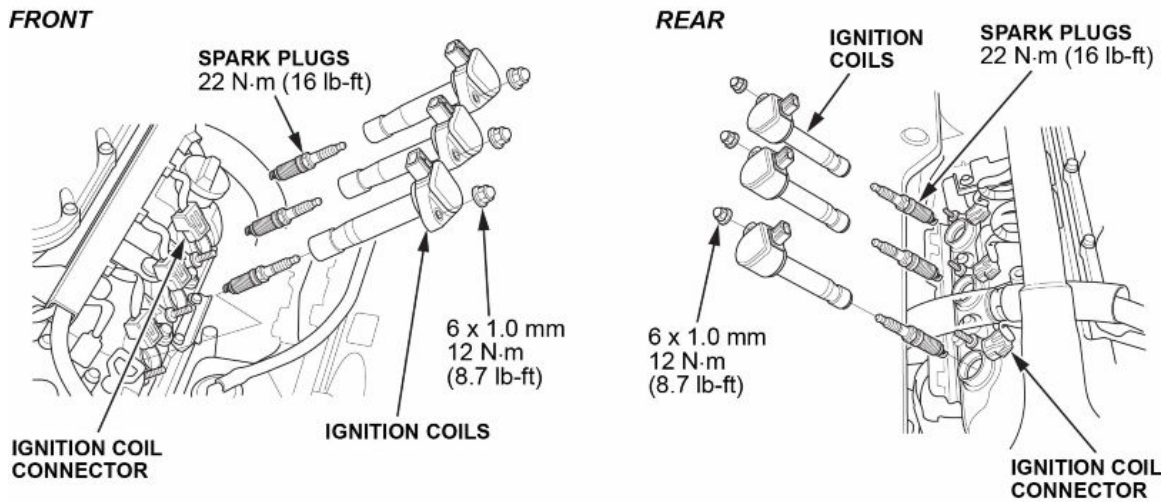

34. Depending on the diagnosis, remove some or all of the following:

- ECT sensor connector
- Front rocker arm oil pressure switch connector
- Rear rocker arm oil pressure switch connector
- CMP sensor connector
- Front A/F sensor one connector
- Rear A/F sensor one connector
- Front secondary HO2S connector
- Rear secondary HO2S connector
- Rocker arm oil control solenoid A connector (bank one)
- Rocker arm oil control solenoid A connector (bank two)
- Rocker arm oil control solenoid B connector (bank one)
- Alternator connector and positive alternator cable
- A/C clutch switch connector
- EGR 5P valve connector
- Engine ground
- Knock sensor
- Fuel injector connectors and clips

35. Remove the quick-connect fitting cover, then disconnect the fuel feed hose.

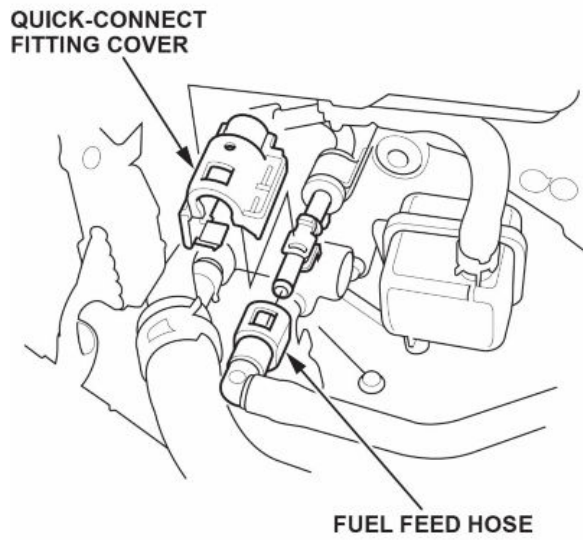

36. Remove the EVAP canister purge joint with the bracket.

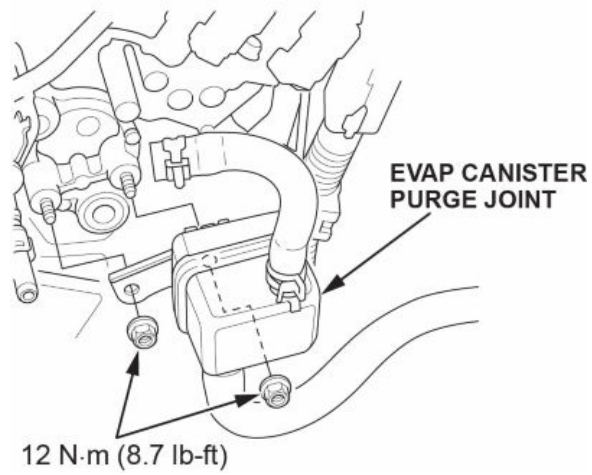

37. Remove the fuel rail connecting joint hose (Quick-Connect fitting).

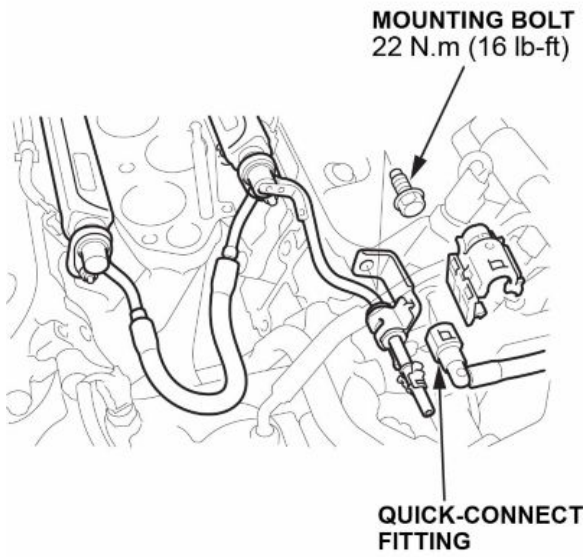

38. Remove the EGR pipe mounting bolts, then remove the EGR pipe.

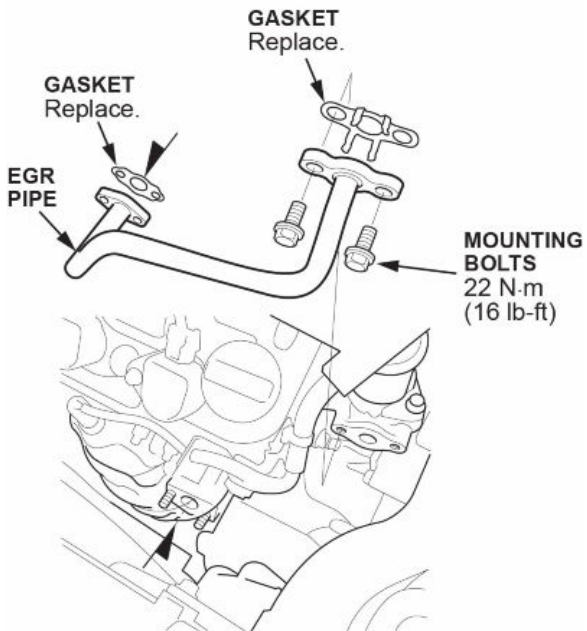

39. Separate the water passage from the heads.

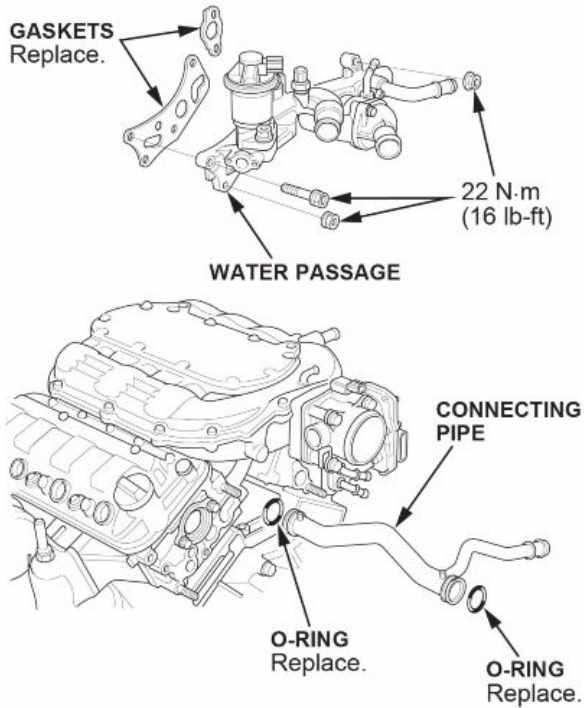

40. Remove the appropriate WU-TWC depending on diagnosis.

NOTE: Set the WU-TWC aside and cover the opening with shop towels to prevent coolant from entering.

FRONT

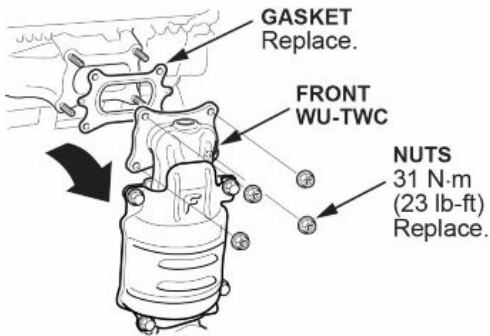

REAR

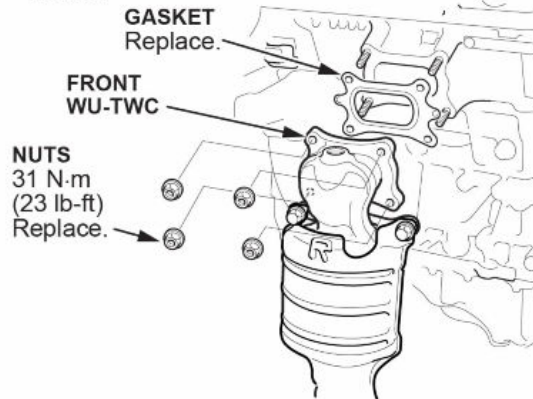

41. Remove the appropriate head with the injector base attached.

NOTE: Depending on diagnosis, you will remove the rear bank head or both heads.

FRONT

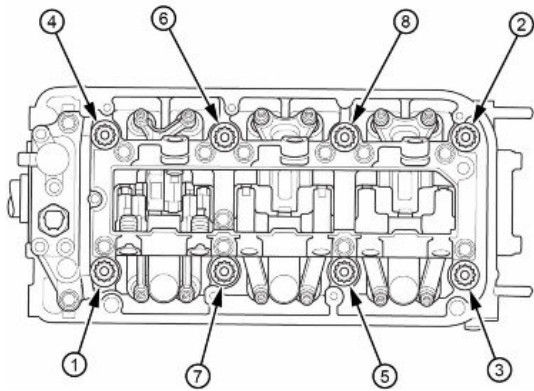

REAR

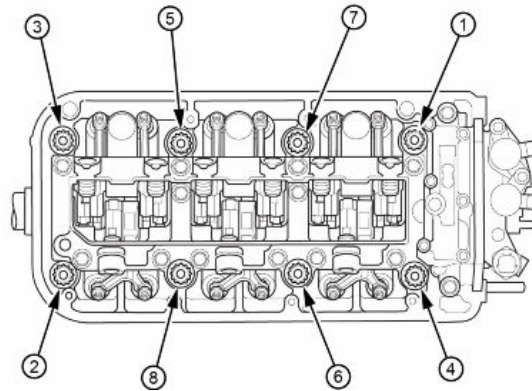

42. Measure the head bolts to determine if they need replacement. If either diameter is less than **11.3 mm (0.445 in.)**, replace the cylinder head bolt.

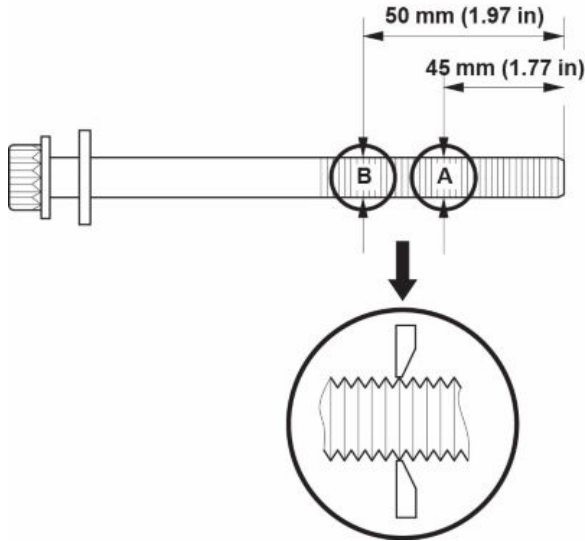

NOTE: Below are the head bolt torque specifications for reinstallation.

- 42.1. Apply new engine oil to the threads and under the bolt heads.
- 42.2. Torque the cylinder bolts in sequence to **29 N•m (22 lb-ft)**.
- 42.3. Tighten in sequence an additional **90 degrees** (third step).
- 42.4. Tighten in sequence an additional **90 degrees** (fourth step).
- 42.5. If the bolts are new, tighten an additional **90 degrees**.

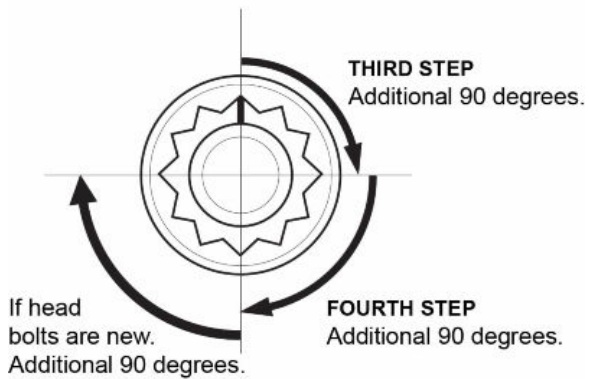

43. Raise the vehicle.

44. Remove the CKP sensor cover and bolts, then disconnect the CKP sensor connector.

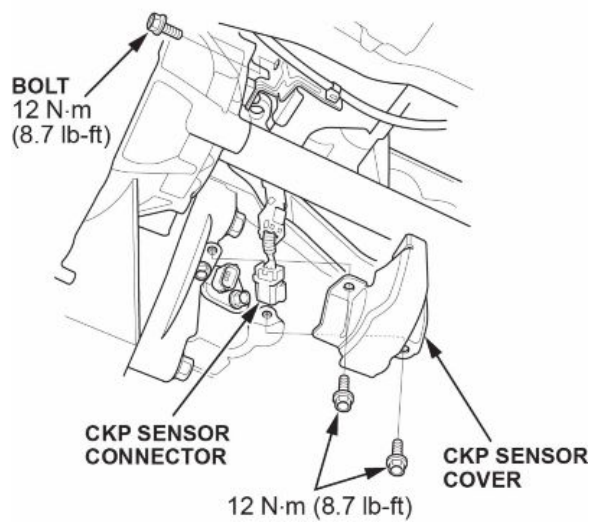

45. Remove the torque converter case cover and the four bolts securing the oil pan to the transmission.

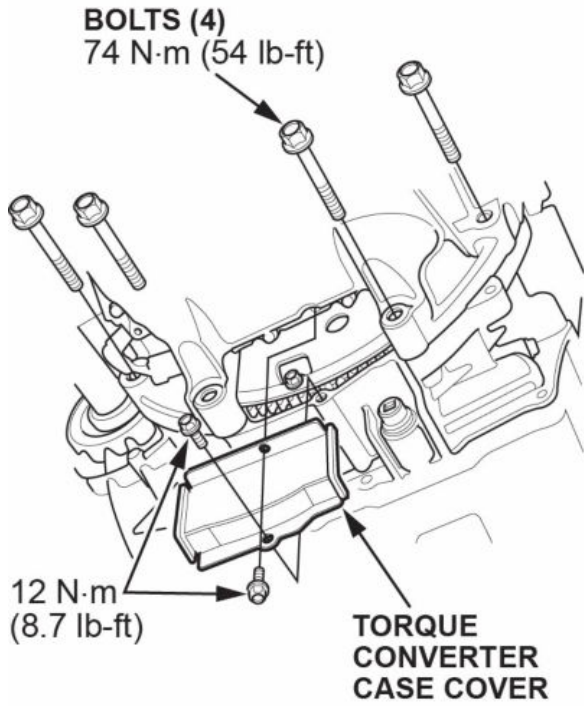

46. Remove all bolts securing the oil pan.

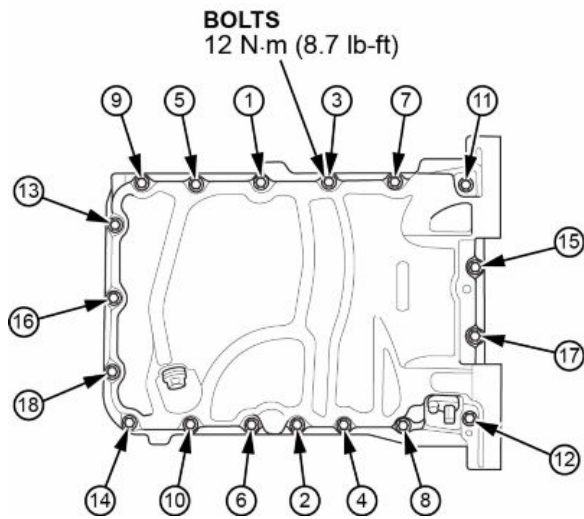

47. Using a flat blade screwdriver, separate the oil pan from the engine block in the areas shown.

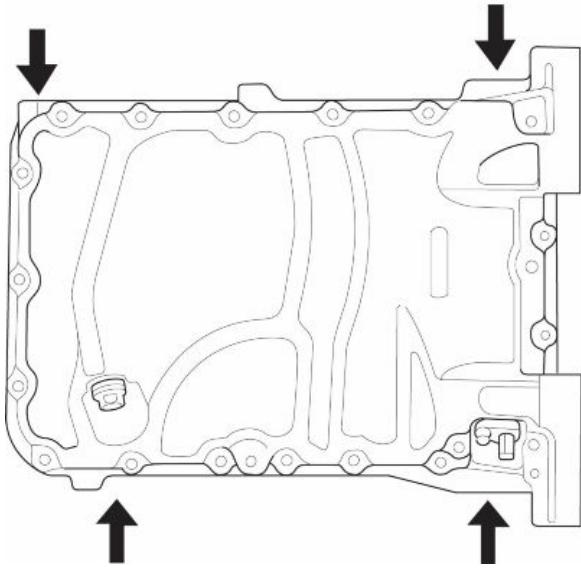

48. Remove the oil strainer and baffle plate.

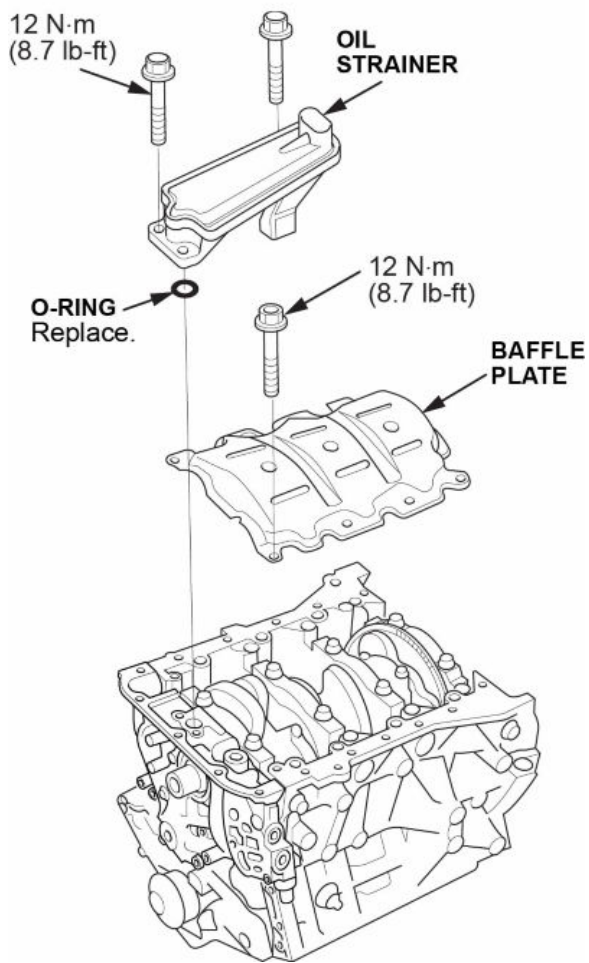

49. Lower the vehicle to a comfortable working height, and place a clean shop towel around the cylinder wall to prevent debris from entering the coolant passage.

50. Remove the appropriate piston depending on diagnosis.

NOTE:

- Before removing the rod caps, use a grease pencil or suitable marking pen to mark each cap and its corresponding connecting rod with the cylinder number it came from.
- Do not confuse the existing marking on the side of the connecting rod and rod cap with a cylinder number. They are just manufacturing marks referring to the size of the big end of the rod.
- Installing a rod cap incorrectly will result in engine knock and/or engine failure. Remove and mark one rod assembly at a time to make sure it is assembled correctly.
- When torquing the rod cap bolts, refer to the service information for details.
- Click [HERE](#) to go to the Tech2Tech® video “Tips When Working with Fracture Rods”.

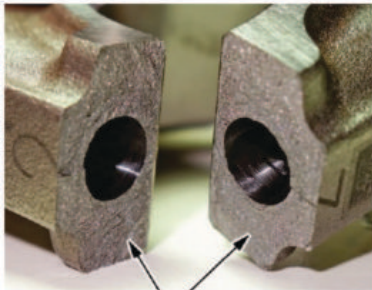

The uneven mating surfaces are uniquely matched and not interchangeable.

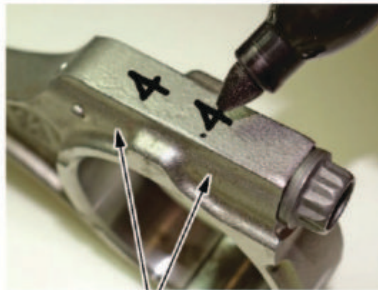

Mark the connecting rod and rod cap with the cylinder number.



These are manufacturing marks, and do not indicate the cylinder number.

51. Visually inspect all the connecting rod bearing for signs of damage.

NOTE:

- If your fingernail catches on a scratch or groove in the bearing, replace it. Pictured are normal reusable rod bearings after about 35,000 miles. Some discoloration is normal and does not require replacement.
- If the bearings look like they must be replaced, contact your DPSM for authorization.



52. Cylinder Wall Inspection. If vertical scratches are noted in the cylinder wall, refer to Job Aid Using Cylinder Wall Inspection Tool and or Tech2Tech "Using Cylinder Wall Inspection Tool".

NOTE: Do not use finger nail or pencil lead to determine if engine block is usable. Light to moderate scratches that are detected with your finger nail will pass the inspection when using the cylinder wall inspection tool.

- If the engine block is **good**, go to PISTON CLEANING PROCEDURE and clean the appropriate piston.
- If the engine block is **no good**, replace the engine block. The block comes with updated pistons. This bulletin no longer applies. You must obtain DPSM authorization and refer online to **Engine Removal and Installation** to reinstall the engine.

Piston Cleaning and Ring Replacement Procedure

1. Remove the piston rings from the piston using a ring expander. Be careful not to damage the piston.

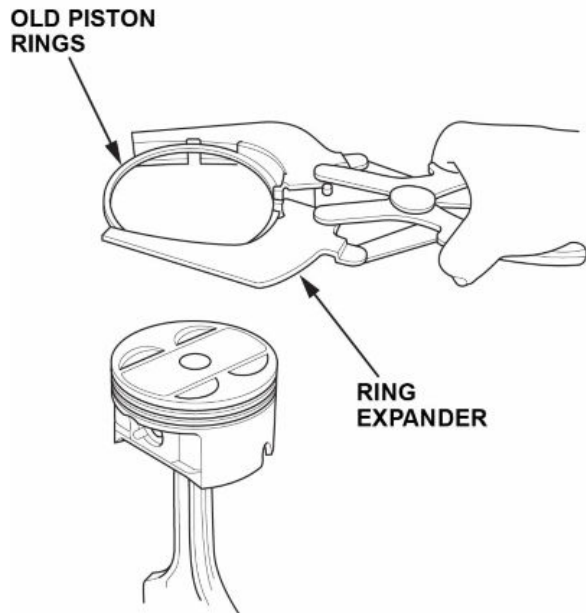

2. Spray the piston head and piston ring grooves thoroughly with Honda throttle plate cleaner.
3. While holding the piston upright in your left hand, take the piston ring groove cleaner tool in your right hand and line up the cleaner tool guides with the second (middle) piston ring groove.



4. Press the handle on the piston ring groove cleaner tool and slide the cleaning bit onto the appropriate piston ring grooves.



5. Once the cleaning bit is in the appropriate ring grooves of the piston, make sure the tool handle clicks in to place.
NOTE: There is only one notch on the tool for the handle to engage.

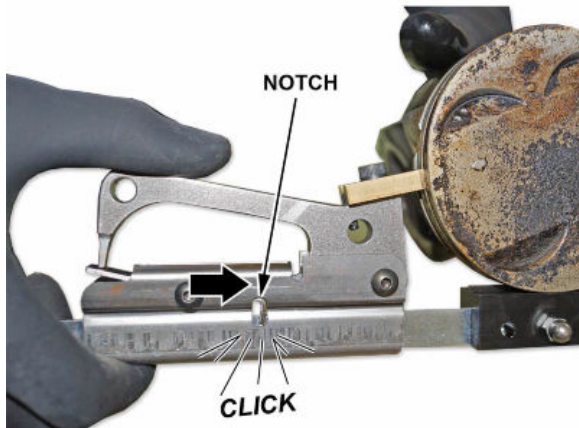

6. Hold the piston steady and rotate the tool counter-clockwise five to six times to remove any carbon deposits in the piston ring grooves. **Do not** rotate the tool clockwise.

NOTE: You can watch this procedure in the Tech2Tech segment "How to Clean Piston Ring Grooves".



7. Remove the piston groove cleaning tool and clean off the carbon from the tool bit.

8. Finish cleaning the piston with throttle plate cleaner and the nylon brush. Do not use a steel wire brush.



NOTE: Below are some examples of before and after pictures. Depending on mileage and running conditions, the pistons will achieve different levels of cleanliness.

54K PISTON

87K PISTON

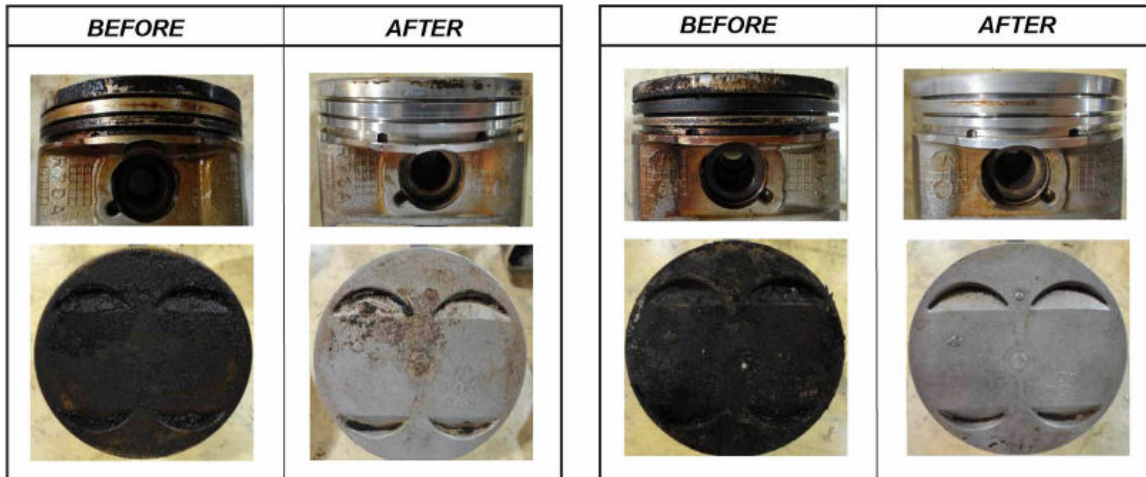

9. Install the piston rings as shown.

NOTE: The first (top) ring has a 1R manufacturing mark and the second (middle) ring has an 2R manufacturing mark. The manufacturing marks must be facing upward.

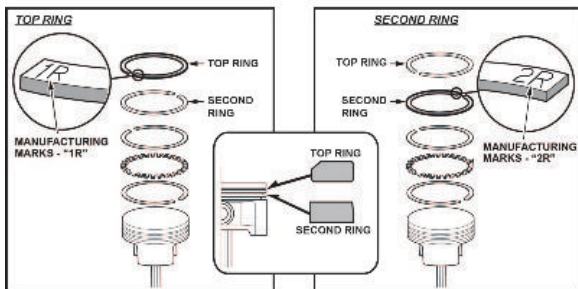

10. Rotate the rings in their grooves to make sure they do not bind.

11. Position the ring end gaps as shown.

NOTE: If the ring gaps are not positioned correctly, excessive blowby may occur.

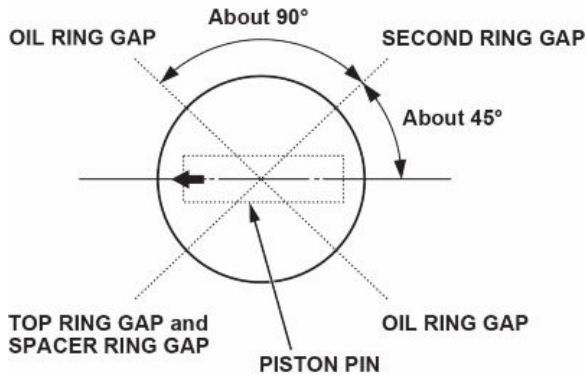

12. Apply new engine oil to the piston, the inside of the piston ring compressor, and the cylinder bore.

NOTE: **Cylinder wall honing is NOT required for this repair.**

13. Install the piston/connecting rod assembly into the cylinder bore with the arrow on top of the piston facing the timing belt side of the engine.

NOTE: Be careful not to damage the cylinder wall when installing the piston.

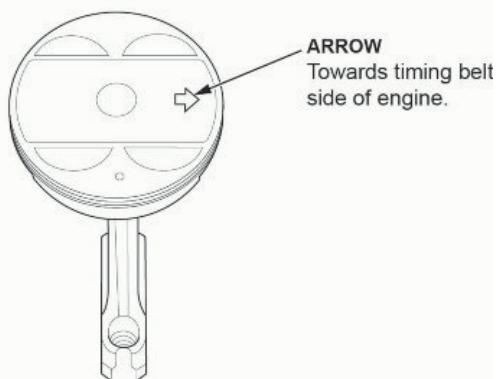

14. Set the piston in the ring compressor, and position the piston in the cylinder based on the rod/cap marks that you made in step 50.

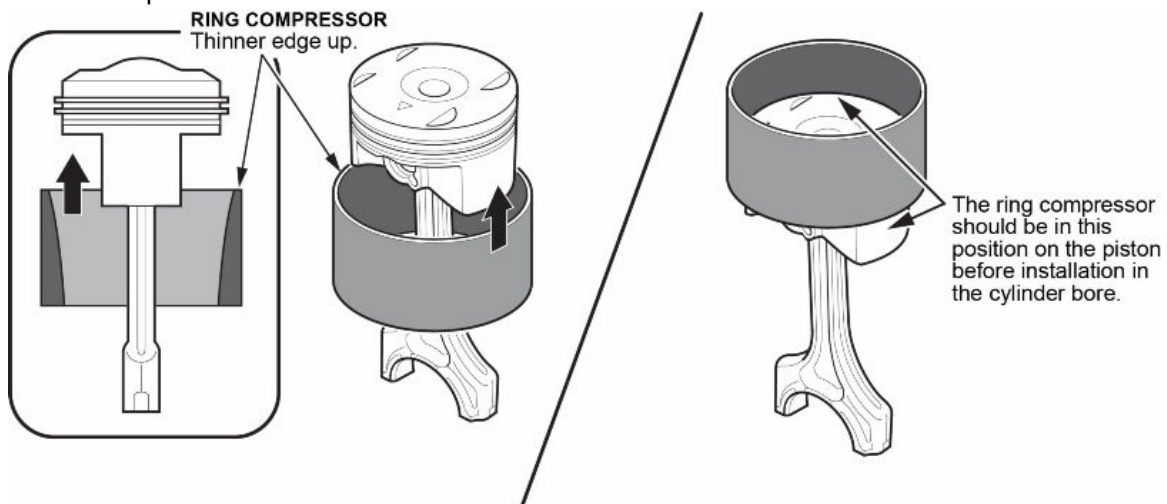

15. Set the ring compressor on the piston bore, then push the piston in with your hands.

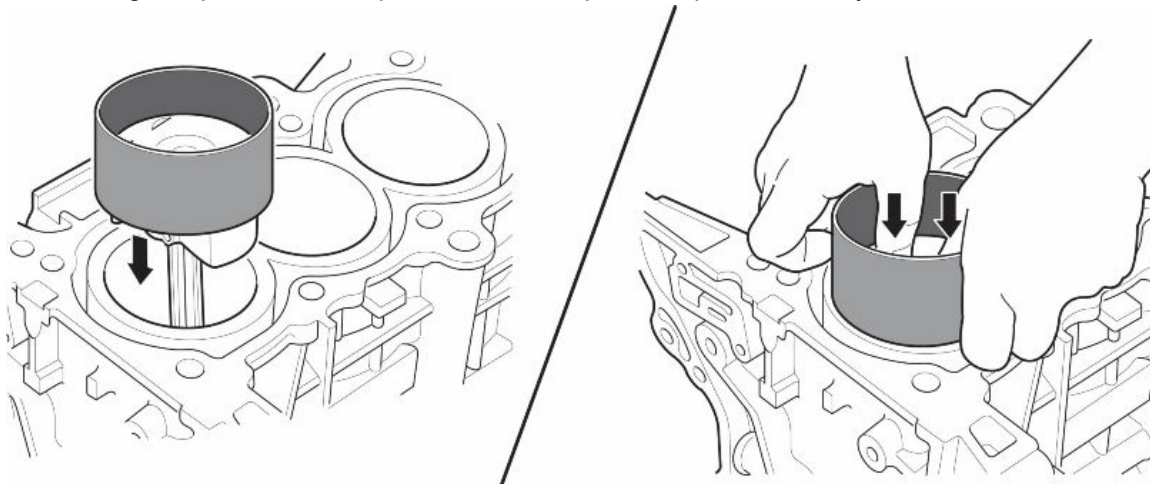

16. Stop after the ring compressor pops free, and check the connecting rod-to-rod journal alignment before pushing the piston into place.

17. Measure the diameter of the connecting rod bolts to determine if they need replacement. Calculate the difference in diameter between point A and point B. It should not be more than **0–0.1 mm (0–0.004 in)**.

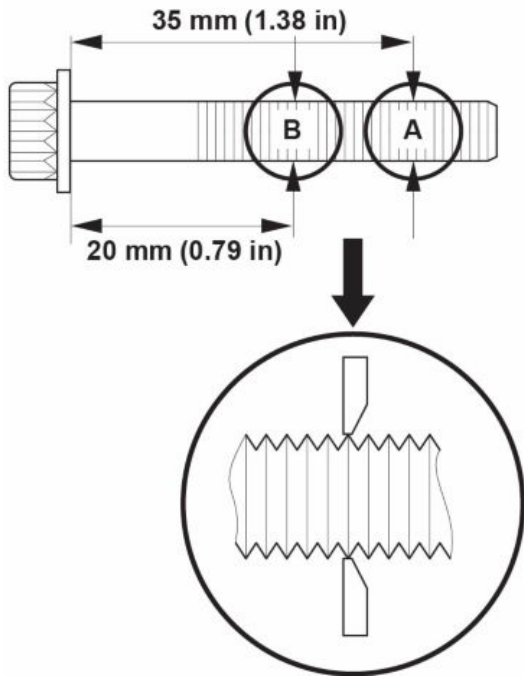

18. Apply new oil to the connecting rod bolt threads and flanges. Torque the bolts to **20 N•m (14 lb-ft)** then tighten the connecting rod bolts an additional **90 degrees**.

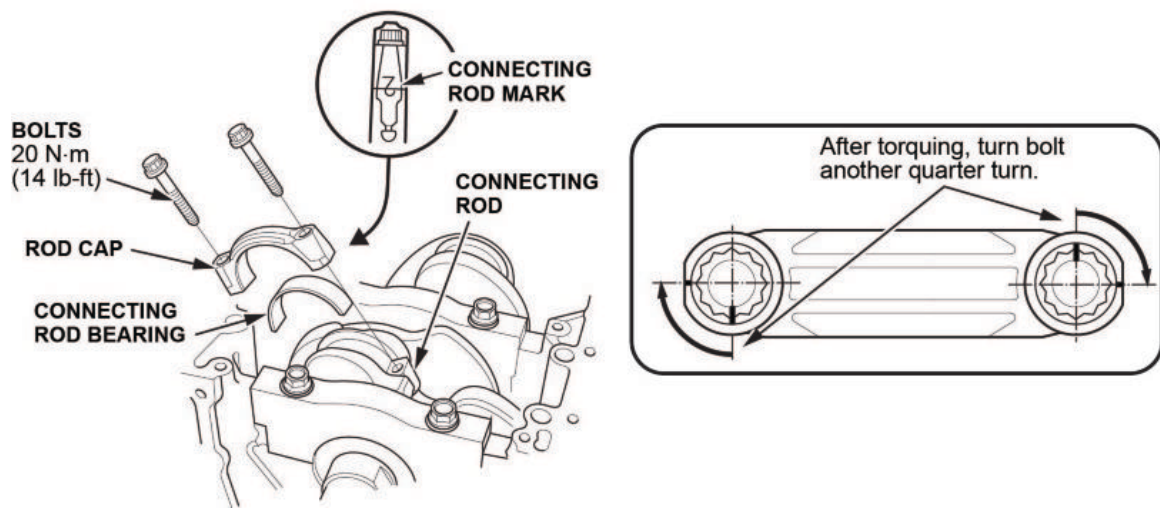

- 19. Reinstall the remaining components in the reverse order of removal.
- 20. Replace spark plugs 1–4.
- 21. Replace the oil filter and refill all fluids.
- 22. Do the idle learn procedure.

END