

July 19, 2022

Version 1

Power Tailgate Wont Stay Open

AFFECTED VEHICLES

Year	Model	Trim	VIN Range
2018–21	Odyssey	ALL Except LX and EX	ALL
2022	Odyssey	ALL Except LX and EX	5FNRL6H....000001 thru 5FNRL6H....044328

SYMPTOM

After powering open, the tailgate either slowly sags down or the power tailgate control unit sounds a warning tone before powering the tailgate closed.

POSSIBLE CAUSE

The right tailgate spring internal damper is damaged and does not have sufficient pressure to support the tailgate.

CORRECTIVE ACTION

Replace the right tailgate spring assembly.

PARTS INFORMATION

Part Name	Part Number	Quantity
Power Tailgate Spring Assembly	74981-THR-A01	1
Trim Pillar Clip	91561-TA5-A11	2

CUSTOMER INFORMATION:The information in this bulletin is intended for use only by skilled technicians who have the proper tools, equipment, and training to correctly and safely maintain your vehicle. These procedures should not be attempted by "do-it-yourselfers," and you should not assume this bulletin applies to your vehicle, or that your vehicle has the condition described. To determine whether this information applies, contact an authorized Honda automobile dealer.

WARRANTY CLAIM INFORMATION

The normal warranty applies.

Operation Number	Description	Flat Rate Time	Defect Code	Symptom Code	Template ID	Failed Part Number
823130	Replace the right tailgate spring assembly.	1.1 hr	03001	03217	A22018A	74981-THR-A01

REPAIR PROCEDURE

1. Remove the cargo light.

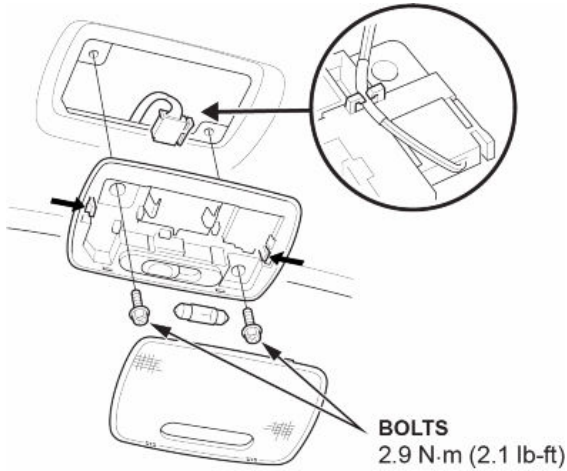

2. Remove the rear roof trim.

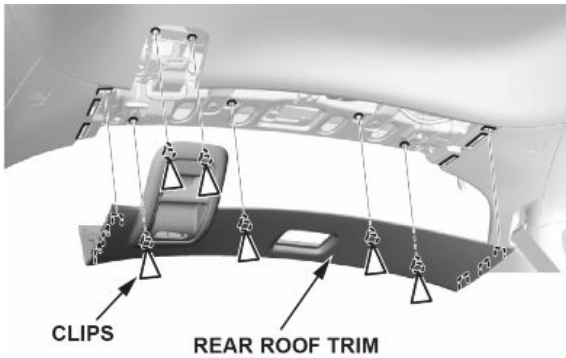

3. Remove the rear cargo area trim panel.

3.1. Set the third row seats upright.

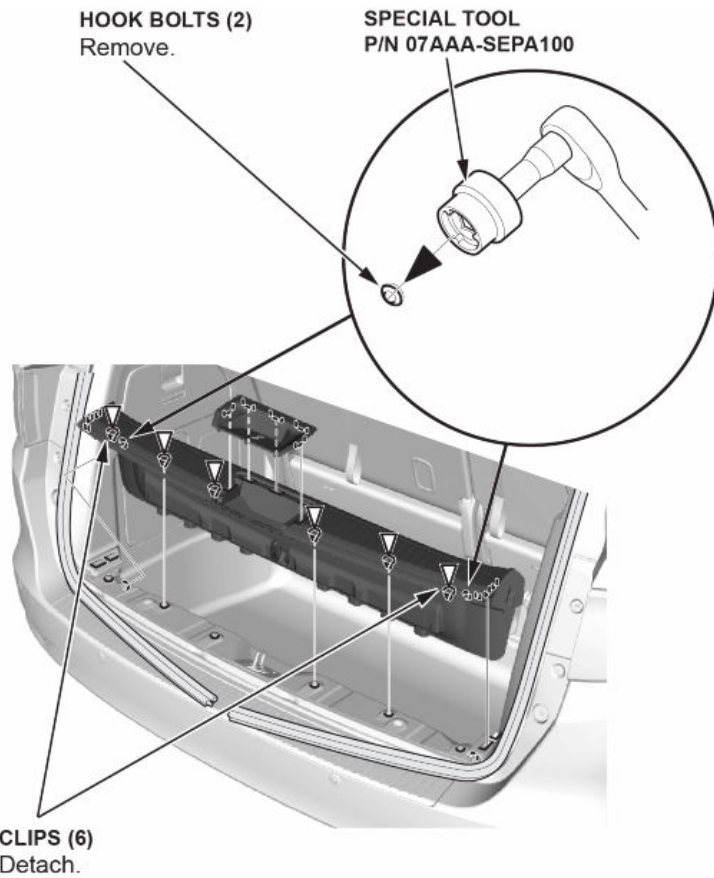

3.2. Remove the weatherstrip as needed.

3.3. Remove the rear trim panel. If necessary, use special tool 07AAA-SEPA100 to remove the hook bolts.

3.4. Fold down and stow the third row seats.

4. Remove the right and left sliding door sill upper trims.

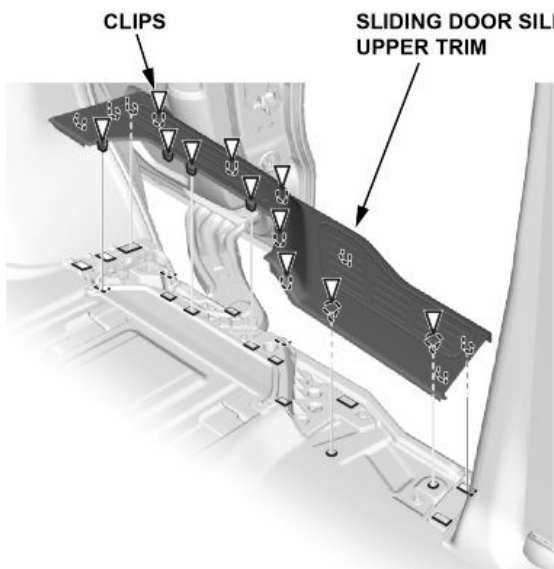

5. Remove the weatherstrip along the right and left rear side trim panels as needed to detach the side rear trim panels from the C-pillar.

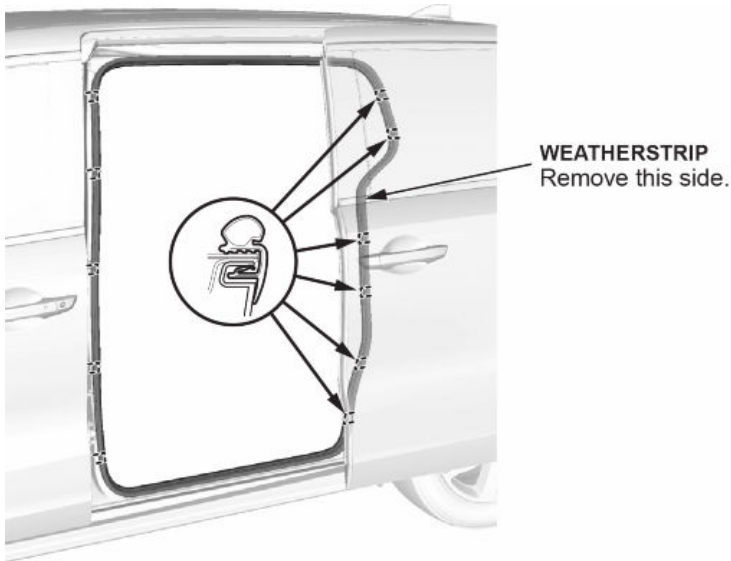

6. Detach the top of the right and left side rear trim panels from the C-pillar and D-pillar trims to create enough clearance for removing the C-pillar and D-pillar trims.

NOTE: It is not necessary to remove the rear trim panels from the vehicle.

- 6.1. Remove the hook bolts and screws/fasteners behind the access panels as shown below.
- 6.2. If equipped, remove the HondaVAC hose from the vacuum.

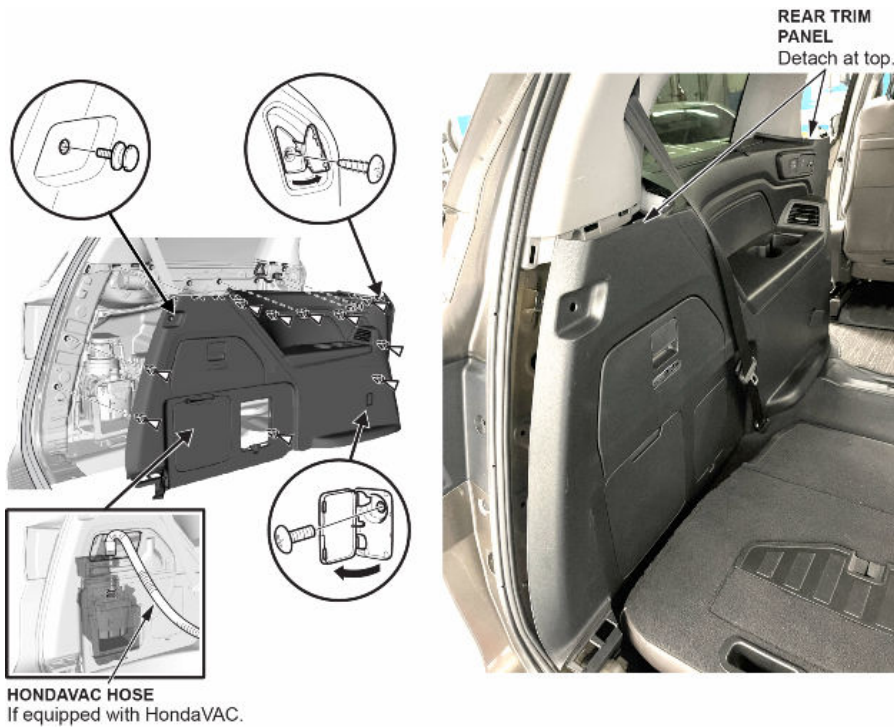

7. Remove the D-pillar trim.

NOTE:

- Disconnect the satellite speaker connector if equipped.
- To prevent scuffing/marring when the D-pillar trims are removed, lean them against the side trim panels as shown.

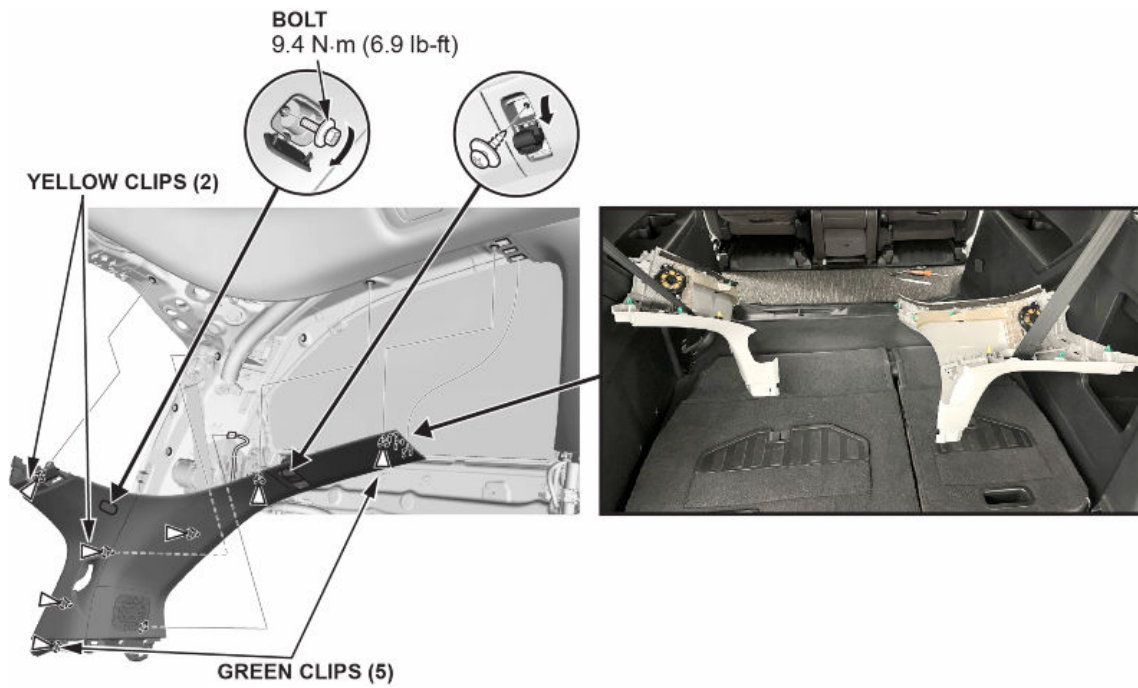

8. Remove the C-pillar trim.

8.1. Hit the upper clip in the C-pillar trim with a rubber mallet. Hitting the clip breaks the projections on the pin, and pushes it into the grommet on the body.

NOTE:

- Make sure you only strike the trim in the area indicated to avoid damaging the trim.
- Place a clean shop towel over the trim to prevent a dirty mallet from discoloring the trim.
- Hitting the clip breaks the projections on the pin and pushes it into the grommet on the body.
- The upper clip must be replaced with a new one when the C-pillar trim is reinstalled.

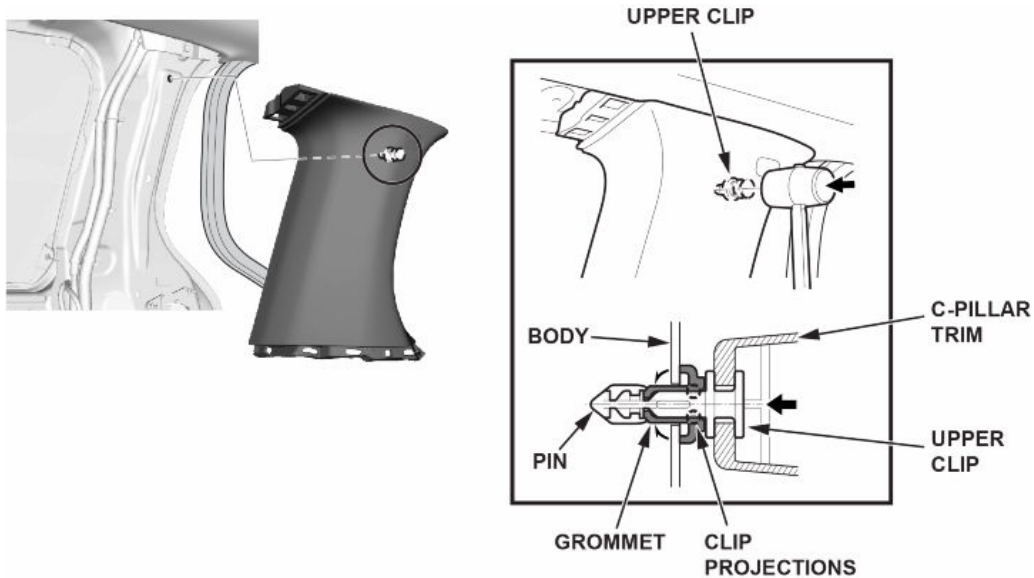

8.2. Pull back the top of the C-pillar trim by hand to remove the upper clip from the body.

9. Remove the 2nd row center seat belt cover.

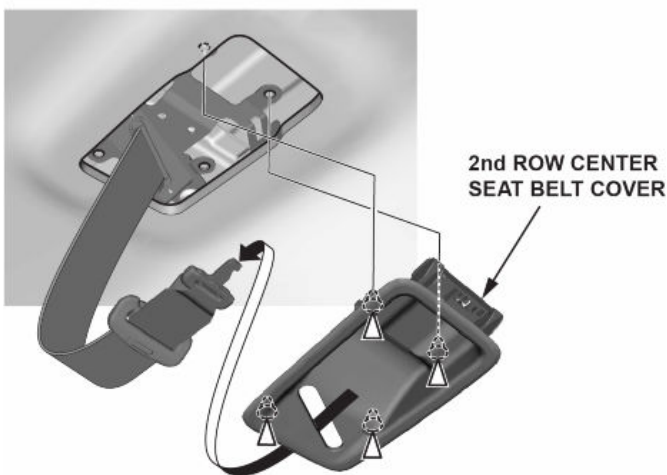

- 10. Remove the right and left rear slide door grab handles.
 - 10.1. Lower the grab handle.
 - 10.2. Using special tool (07AAC-001A100), remove the caps.
 - 10.3. Squeeze the clips with pliers, then remove the grab handle.

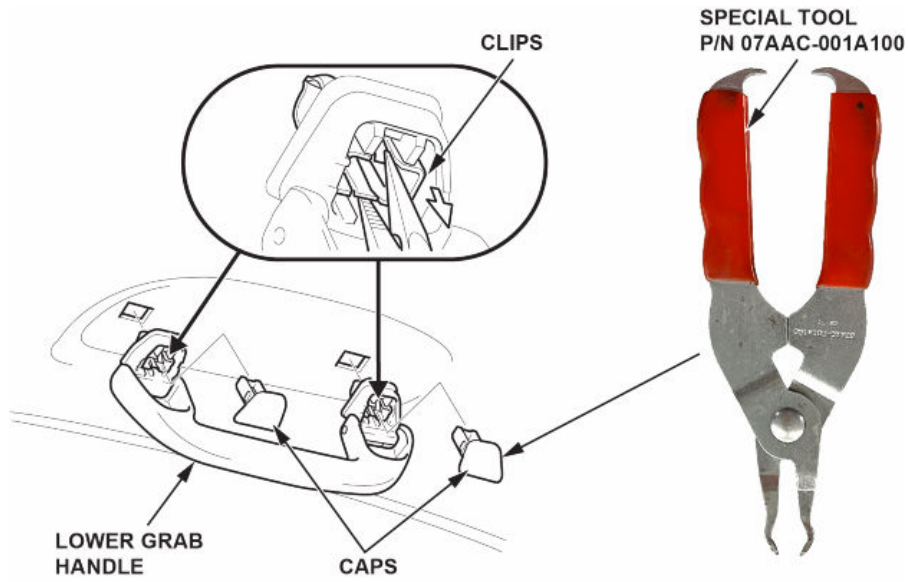

- 11. Lift the tailgate to the full open position and support it with an adjustable floor stand.
NOTE: Cover the shop stand with a clean shop towel to prevent damaging the tailgate trim.



12. Remove the left side tailgate motor from the hinge ball stud.

NOTE: This step must be taken before removing the right support strut to avoid damaging the power tailgate motor. The right tailgate support strut is under additional tension which requires lifting the tailgate beyond the limits of the tailgate motor to safely release the right support strut from the tailgate hinge and bodyside ball studs.

12.1. Insert a small flat tip screwdriver in the flat area under the spring clip as shown.

NOTE: Do not attempt to remove the clip.

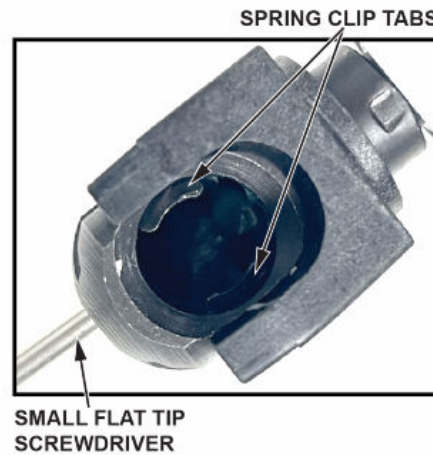
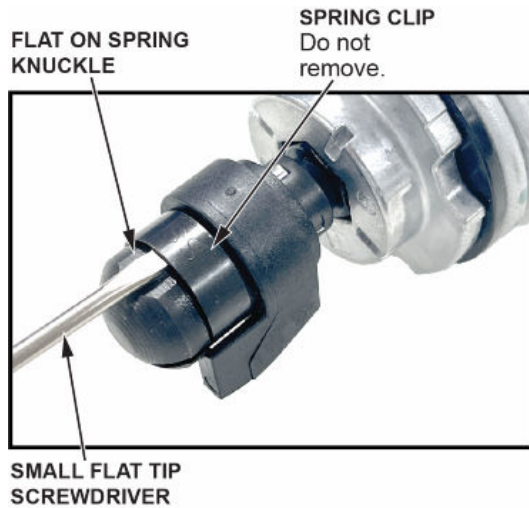

12.2. Use another screwdriver or pry tool to pull the end of the tailgate motor from the hinge ballstud.

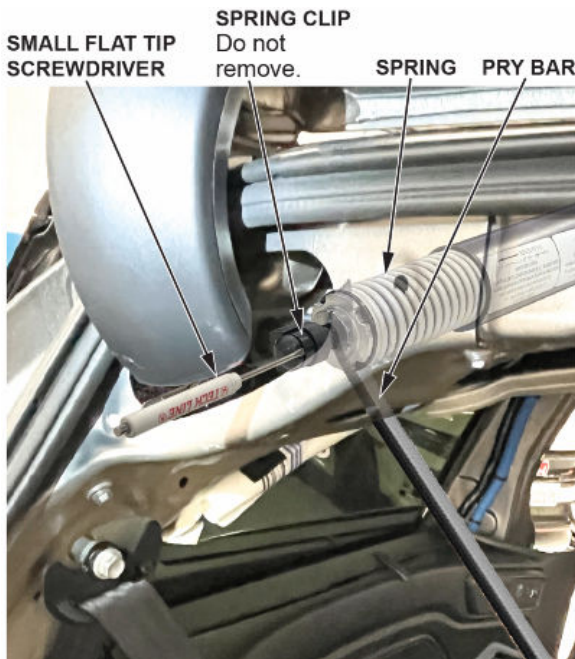

13. After the tailgate motor is released, push open the tailgate to the top of the hinge stroke and adjust the stand to support it in that position.



14. Pull the clips out of the roof panel.

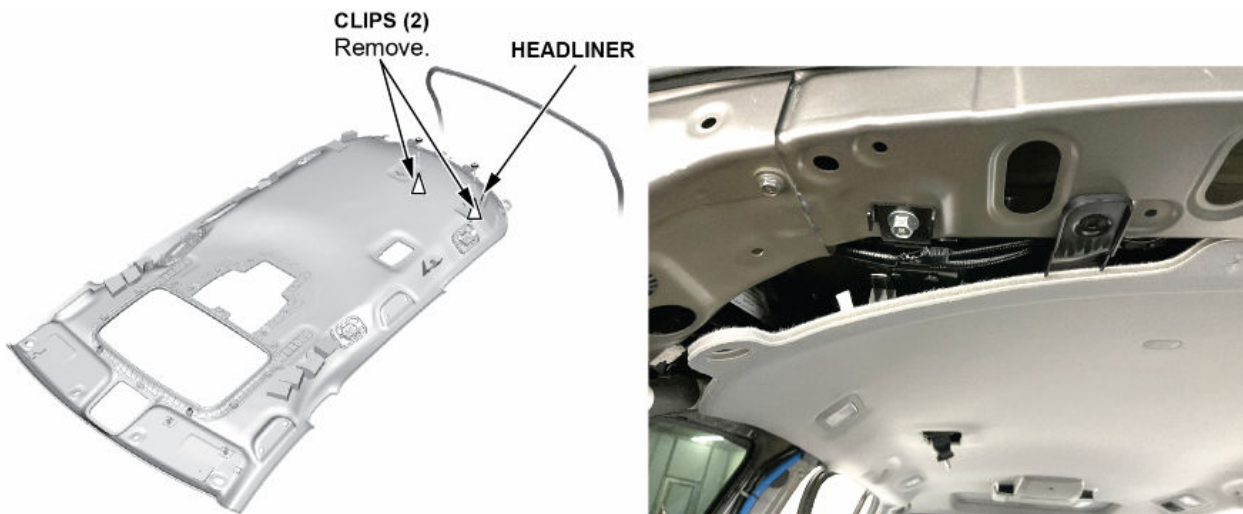

15. Remove the right tailgate spring cover base.

15.1. Gently pull down the headliner taking care to avoid creasing or damaging the headliner.

15.2. Remove clips.

15.3. Loosen the bolts and remove the cover.

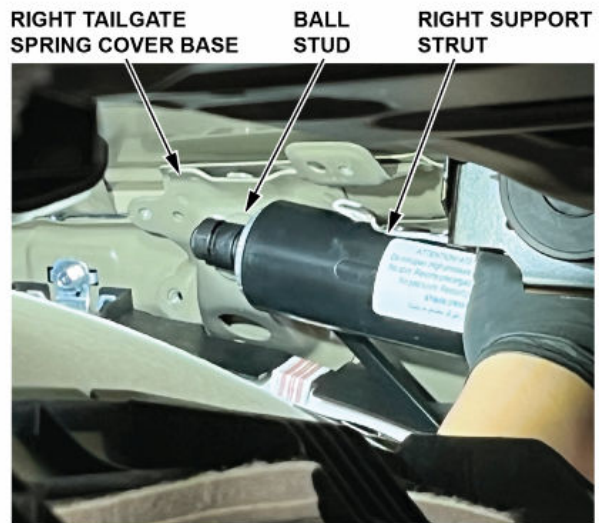
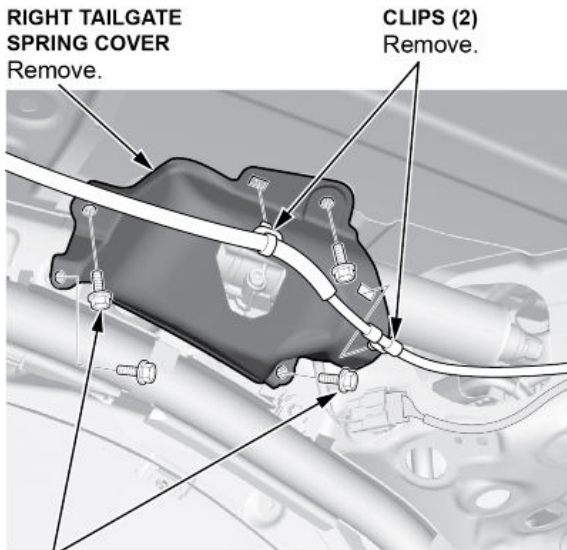

16. Remove the right support strut from the ball studs and install a new one.



17. Install the parts removed in the reverse order of the removal procedure and do the following:

17.1. Replace the C-pillar trim upper clip with the new clip.

17.2. If equipped, confirm the rear satellite speaker harnesses are attached.

END