

This document is uncontrolled when printed. Before use, check the Knowledge Base within the McLaren Retailer Portal to verify that this is the current version.

Document Information

Location: Chassis

Topic: Information relating to the replacement and diagnosis of steering pumps

Condition: Intermittent

Diagnostic Trouble Codes: N/A

Measure

During the replacement or diagnosis of a suspected faulty steering pump (EHPAS), it is necessary to inspect the ground for the pump power supply circuit. Poor grounding of the steering pump can lead to intermittent warning messages or sporadic steering pump behaviour.

CARE POINT: Note Figure 1.1 should only be used as a reference diagram and is not representative of a vehicle wiring diagram

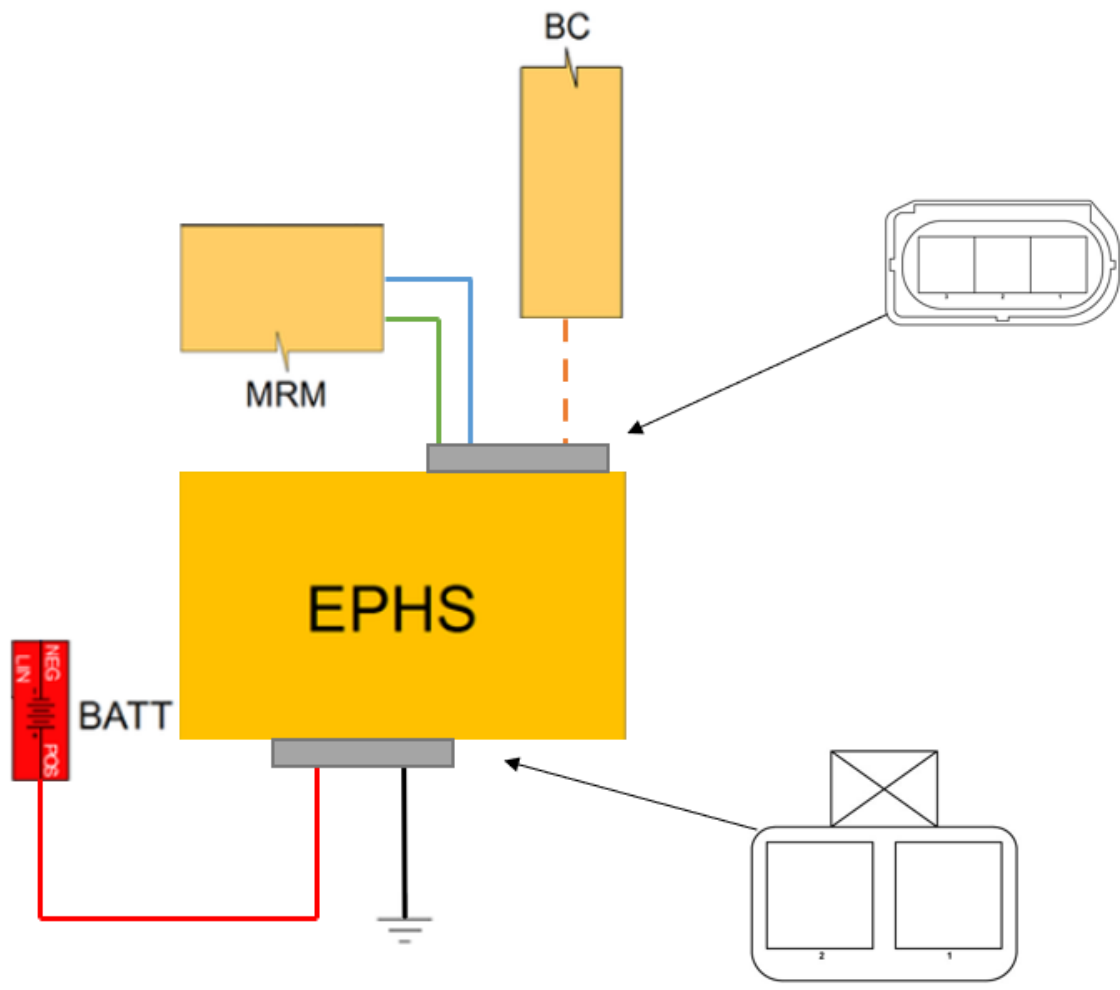

Figure 1.1 – Reference Diagram for EPHS Circuit

Please see **figure 1.2** for an example of poor grounding for the EPHAS circuit. For all models, Ground Point 5 located on the front subframe will need to be cleaned and inspected. The relevant wiring diagram must be consulted to locate Ground Point 5.



Figure 1.2 – Examples of poor grounding for Steering Pump

If damage to the harness is found, please proceed to submit a Technical Request.

Parts Information

N/A

Attachments

N/A