



STAR ONLINE PUBLICATION



Case Number: S2023000011 Rev A

Release Date: May 2021

Symptom/Vehicle Issue: Wind Noise And Or Gap At Front Door Mirror Flag

Customer Complaint/Technician Observation: Wind whistle or flutter noise heard coming from the front of the vehicle, A-pillar or windshield frame.

Discussion: Inspect the mirror flag installation. The flag uses 2 metallic clips to retain it to the door. If the clips missing or not fully seated, wind noise can result (fig 2,3). To correct, simply press the clip onto the flag until fully seated. Replace the mirror flag if the clip is missing.

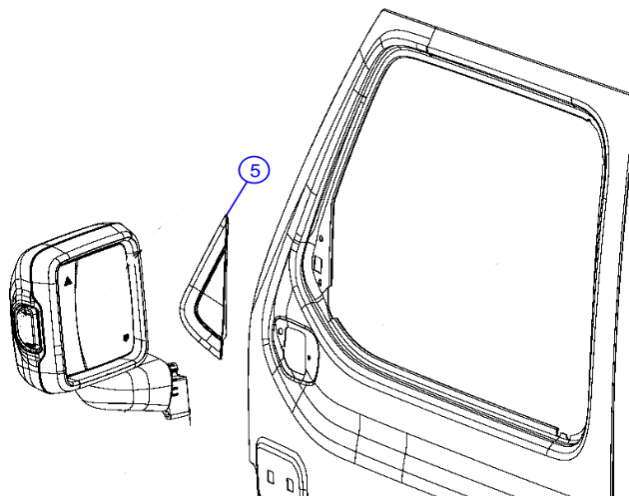

Fig 1

This document does not authorize warranty repairs. This communication documents a record of past experiences. STAR Online does not provide any conclusions about what is wrong with the vehicle. Rather, it captures all previous cases known that appear to be similar or related to the vehicle symptom / condition. You are the expert, and you are responsible for deciding on the appropriate course of action.

Contact STAR Center, or your Technical Assistance Center Via TechCONNECT or eCONTACT ticket if no solution is found



STAR ONLINE PUBLICATION

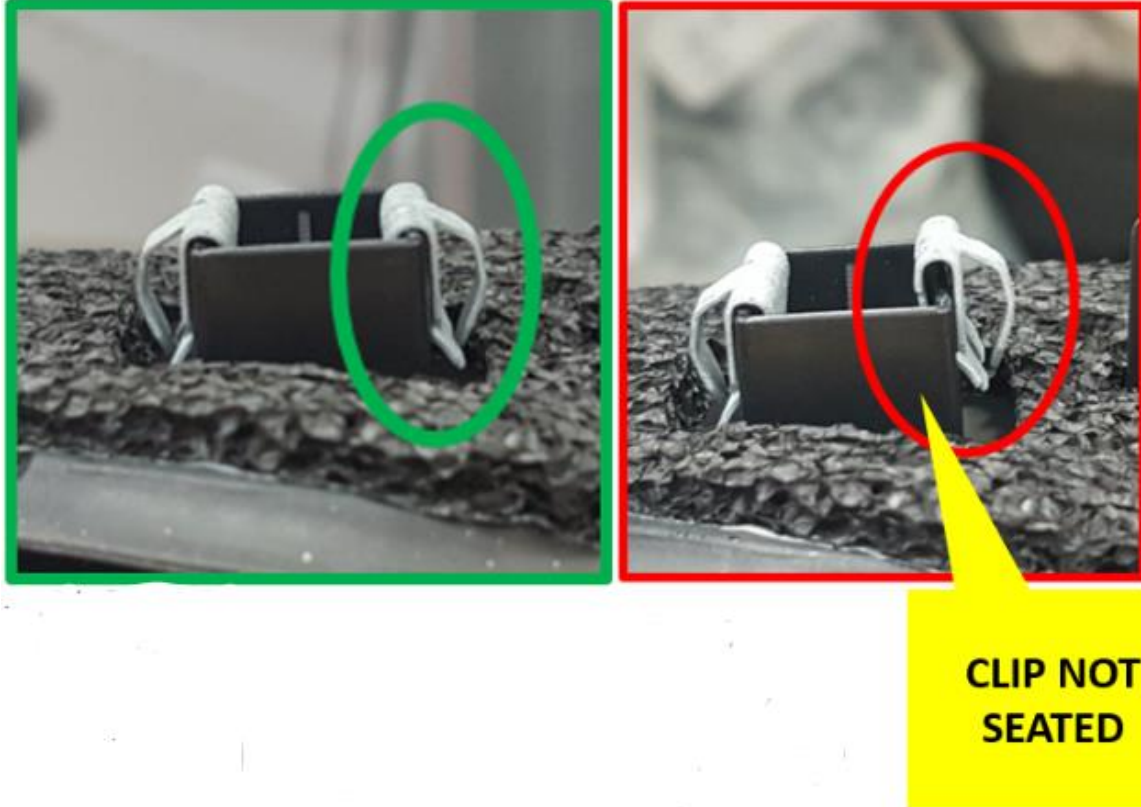

Fig 2

This document does not authorize warranty repairs. This communication documents a record of past experiences. STAR Online does not provide any conclusions about what is wrong with the vehicle. Rather, it captures all previous cases known that appear to be similar or related to the vehicle symptom / condition. You are the expert, and you are responsible for deciding on the appropriate course of action.

Contact STAR Center, or your Technical Assistance Center Via TechCONNECT or eCONTACT ticket if no solution is found



STAR ONLINE PUBLICATION



LH Mirror Applique missing metal clip resulting in wind noise and fluttering noise above 40 mph.

Fig 3 Clip missing

This document does not authorize warranty repairs. This communication documents a record of past experiences. STAR Online does not provide any conclusions about what is wrong with the vehicle. Rather, it captures all previous cases known that appear to be similar or related to the vehicle symptom / condition. You are the expert, and you are responsible for deciding on the appropriate course of action.

Contact STAR Center, or your Technical Assistance Center Via TechCONNECT or eCONTACT ticket if no solution is found