



SIB 01 04 21

2022-08-10

FRONT GRILLE UPPER/LOWER ACTIVE AIR FLAPS: LTD WTY EXT TO 15 YEARS/150,000 MILESThis Service Information bulletin (Revision 01) supersedes SI B01 04 21 **dated September 2021****What's New:**

- The Cause, Procedure, Part, and Claim Information Sections have been updated.

MODEL

E-Series	MY	Model Description	Production Dates	Engine
G30	2018 - 2019	530e iPerformance	February 22, 2017 to June 14, 2019	XB1H
G30	2018 - 2019	530e xDrive iPerformance	February 22, 2017 to June 27, 2019	XB1H

Note: The Model information above is for informational purposes only, it is not the only deciding factor.

The 2018 Model Year 530e iPerformance Sedans/530e xDrive iPerformance Sedan model vehicles were removed from [SI B01 01 19](#) and were added to this bulletin, September 2021.

For upper and lower active air flap extended limited warranty coverage that applies to other vehicles, refer to [SI B01 01 19](#) and [B01 12 19](#).

Eligible Vehicles

To assist you in identifying those vehicles that have this component-specific extended limited warranty coverage, the DCSnet Warranty Vehicle Inquiry has been updated with the VIN and Component-specific Vehicle Comment shown below:

Please see SI B01 04 21 (DC 51 64 90 01 00): For this vehicle, the Radiator Grille Upper and Lower Active Air Flaps limited emission-related warranty for defects in materials or workmanship has been extended to 15 years/150,000 miles as determined from the original in-service date. This coverage is subject to the same vehicle eligibility requirements, limitations, and exclusions that apply to the BMW New Vehicle Limited Warranty. Vehicles that are registered in California or a State that has fully adopted the State of California TZEV emission regulation (model year dependent), the standard emission-related coverage for these components are 15 years/150,000 miles (Replaces the 10/120 coverage).

Note: Before performing a repair and submitting a claim, first confirm that the vehicle has the above Notice of Limited Warranty Extension in the DCSnet Warranty Inquiry Vehicle Comments section.

If you have ELW eligibility and/or coverage questions, please contact the Warranty department through IDS by selecting Coverage, Policy, Coding Questions and Mileage Corrections prior to performing any repair.

SITUATION

Please see attachment for complete details.

Supporting Materials

[picture_as_pdf B010421 Cust Letter.pdf](#)

[picture_as_pdf B010421.pdf](#)

Service Information Bulletin

Warranties

August 4, 2022

B01 04 21

FRONT GRILLE UPPER/LOWER ACTIVE AIR FLAPS: LTD WTY EXT TO 15 YEARS/150,000 MILES

This Service Information bulletin (Revision 01) supersedes SI B01 04 21 dated September 2021

What's New:

- The Cause, Procedure, Part, and Claim Information Sections have been updated.

MODEL

E-Series	MY	Model Description	Production Dates	Engine
G30	2018 - 2019	530e iPerformance	February 22, 2017 to June 14, 2019	XB1H
G30	2018 - 2019	530e xDrive iPerformance	February 22, 2017 to June 27, 2019	XB1H

Note: The Model information above is for informational purposes only, it is not the only deciding factor.

The 2018 Model Year 530e iPerformance Sedans/530e xDrive iPerformance Sedan model vehicles were removed from SI B01 01 19 and were added to this bulletin, September 2021.

For upper and lower active air flap extended limited warranty coverage that applies to other vehicles, refer to SI B01 01 19 and B01 12 19.

Eligible Vehicles

To assist you in identifying those vehicles that have this component-specific extended limited warranty coverage, the DCSnet Warranty Vehicle Inquiry has been updated with the VIN and Component-specific Vehicle Comment shown below:

Please see SI B01 04 21 (DC 51 64 90 01 00): For this vehicle, the Radiator Grille Upper and Lower Active Air Flaps limited emission-related warranty for defects in materials or workmanship has been extended to 15 years/150,000 miles as determined from the original in-service date. This coverage is subject to the same vehicle eligibility requirements, limitations, and exclusions that apply to the BMW New Vehicle Limited Warranty. Vehicles that are registered in California or a State that has fully adopted the State of California TZEV emission regulation (model year dependent), the standard emission-related coverage for these components are 15 years/150,000 miles (Replaces the 10/120 coverage).

Note: Before performing a repair and submitting a claim, first confirm that the vehicle has the above Notice of Limited Warranty Extension in the DCSnet Warranty Inquiry Vehicle Comments section.

If you have ELW eligibility and/or coverage questions, please contact the Warranty department through IDS by selecting Coverage, Policy, Coding Questions and Mileage Corrections prior to performing any repair.

SITUATION

Component-Specific Limited Warranty Extension

For the eligible vehicles, BMW of North America, LLC (BMW NA) is extending the limited warranty for the vehicle's **Radiator Grille Upper and Lower Active Air Flaps** to:

- **15 years/150,000 miles as determined by the vehicle's original in-service date**

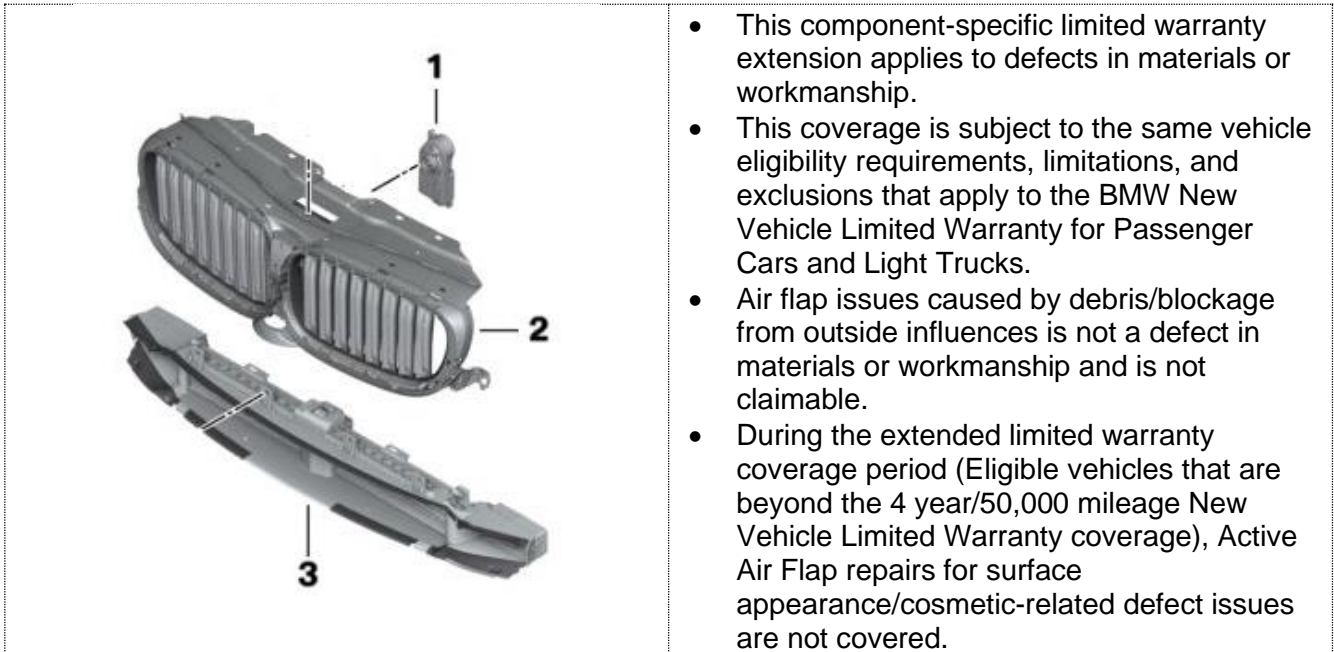

1. Air flap control (link), active upper
1. Air flap control (drive), active upper
2. Air flaps, upper (assembly)
3. Air flaps, lower (assembly)

Note: This bulletin is notice of a limited warranty extension. This is NOT a notice of a Recall or Service Action.

There is no immediate repair required unless the BMW vehicle is currently experiencing this problem.

Customer Notification Letter

Even though this is NOT a Recall, BMW NA sent VIN-specific customer notification letters.

CAUSE

A check control message or MIL (Malfunction Indicator Lamp) may be illuminated with faults stored related to the upper and/or lower active air flap(s).

Potential causes include:

- Faulty upper air flap link (G30)
- Faulty upper air flap actuator
- Faulty upper flap assembly
- Faulty lower air flap assembly

Or:

Upon visual inspection, the passenger side upper active air flaps are either stuck open or closed, and they will not move and there are no faults stored for the active air flaps (With no check control message or check engine light or displaying)

CORRECTION

Follow the instructions in the PROCEDURE section.

PROCEDURE

Determine what is the vehicle's current I-level by either using AIR or the Key reader/ISPA NEXT application, so if needed, this information is available.

If an applicable Model vehicle arrives at your center with the issue described above, perform the corresponding diagnosis.

Depending on the root cause, vehicle model, and the location of flap (upper or lower) at issue, as determined and/or as instructed, the vehicle may require one or more of the following correction repairs:

- Upper air flap link (G30)
- Upper air flap actuator
- Upper air flap assembly
- Lower air flap assembly

Follow the diagnostic suggestions in SI B51 12 19 and SI B51 22 19 (Retaining pin G30) as applicable to determine which repair is required for a specific vehicle.

PARTS INFORMATION

G30

Part Number	Description	Quantity
51 12 9 850 687	Retaining pin	1

To determine the part number below that applies to the specific vehicle being repaired, enter the VIN/chassis number either in ETK or AIR, this considers the specific vehicle's equipment and/or options which is necessary for this selection process.

Part Number	Description	Quantity
Refer to ETK	Air flap control (drive), active, upper (see below)	1
Or:		
Refer to ETK	Air flaps, upper (assembly)	1
And/or:		
Refer to ETK	Air flaps, lower (assembly)	1

- **Important:** If the **Air flap control (drive), active, upper** is the issue and it **is available separately** (per ETK), then only replace the upper flap drive to correct this issue.
- Only order these **parts in the quantities needed** to address customers' vehicles that have confirmed failures.
- **Only in conjunction with parts:** When applicable, if ETK/EPC item identifies additional part(s) that must also be replaced/installed in-conjunction with performing a covered repair, these required additional items are also covered under the terms of this extended limited warranty.
- Also refer to ETK/EPC and the repair instructions for onetime-use fasteners/screws and other information regarding repair-related gaskets, seals, fluid and/or lubricants that also need to be replaced/used and claimed.

WARRANTY INFORMATION

The coverage below (A or B) applies to eligible US-specification BMW vehicles that are registered, operated, and have their covered repair performed by an authorized BMW center in the United States (including Puerto Rico) for defects in materials or workmanship.

For the BMW Models listed above:

- A. If the vehicle is registered in the State of California (CA), or another State that has fully adopted the State of California (CA) TZEV regulation (CT, ME, MD, MA, NJ, NY, OR, RI and VT), under the terms of this regulation the standard Front Grille Upper/Lower Active Air Flaps emission-related coverage is 15 years/150,000 miles.
- B. If the vehicle is registered in one of the remaining States, including DE, OR, PA and WA which did not fully adopt the CA TZEV regulation or Puerto Rico, then this component-specific extended limited warranty coverage to 15 years/150,000 miles applies.

This coverage is subject to the same vehicle eligibility requirements, limitations, and exclusions that apply to the BMW New Vehicle Limited Warranty for Passenger Cars and Light Trucks.

The 2018 Model Year 530e iPerformance Sedans/530e xDrive iPerformance Sedan model vehicles were removed from SI B01 01 19 and were added to this bulletin, September 2021.

For upper and lower active air flap extended limited warranty coverage that applies to other vehicles, refer to SI B01 01 19 and B01 12 19.

Active cooling damper control-related fault codes/repairs that are caused by debris/blockage from outside influences is not a defect in materials or workmanship and is not claimable.

During the extended limited warranty coverage period (Eligible vehicles that are beyond the 4 year/50,000 mileage New Vehicle Limited Warranty coverage), Active Air Flap repairs for surface appearance/cosmetic-related defect issues are not covered.

The existing limited warranty coverage for the whole vehicle and other components has not changed.

This coverage supersedes the coverage that is provided under the BMW Certified Pre-Owned Program or any BMW Group Vehicle Service Contract that applies to the vehicle.

Should this component fail again, it is covered by the remaining portion of the extended limited warranty coverage period.

Non-Qualifying Repairs

Repairs performed on ineligible vehicles, eligible vehicles operated and repaired outside the United States and Puerto Rico, and/or the diagnosis and repair of other unrelated issues are not covered by this component-specific limited warranty extension. This exclusion also applies to repairs, including consequential, that were performed using non-genuine BMW parts and/or used passenger car or light truck parts.

Qualifying Repairs - Claim Submission

Claim this work with the defect code and labor operations provided below.

Defect Code:	5164900100	G30 Air flap control system
---------------------	-------------------	------------------------------------

Retaining Pin Replacement

The Vehicle arrives at your center for this Repair (No other Main work will be performed/claimed during this workshop visit)

Labor Operation	Description	Labor Allowance
------------------------	--------------------	------------------------

51 00 001*	Diagnosis and visually inspect the top air flap control (Drive) (Main work)	3 FRU
Or		
00 58 000*	Diagnosis Worktime Flat Rate (See below) (Main work)	3 FRU
And:		
51 74 702	Installing the retaining pin for linkage of the air flap	Refer to AIR

Or:

The Vehicle is already in the Workshop

Labor Operation	Description	Labor Allowance
51 00 001*	Diagnosis and visually inspect the top air flap control (Drive) (Plus work)	2 FRU
Or		
00 58 500*	Diagnosis Worktime Flat Rate (See below) (Plus work)	2 FRU
And:		
51 74 702	Installing the retaining pin for linkage of the air flap	Refer to AIR

Or:

A check engine light or check control message is present for the active air flaps behind the kidney grilles.

Labor Operation	Description	Labor Allowance
00 00 006	Performing vehicle test (with vehicle diagnosis system – checking faults) (Main work)	Refer to AIR
Or:		
00 00 556	Performing vehicle test (with vehicle diagnosis system – checking faults) (Plus work)	Refer to AIR
And:		
61 21 528	Connect an approved battery charger/power supply (indicated in AIR as Charging battery)	Refer to AIR

If you are using a Main labor code for another repair, use the Plus code labor operation 00 00 556 instead of 00 00 006, or exclude (including 61 21 528) when the Vehicle Test is included in another repair.

And, as necessary:

Labor Operation	Description	Labor Allowance
61 00 006*	Performing vehicle diagnosis – test module (Work time)	(WT)
Or		
00 58 500*	Diagnosis Worktime Flat Rate (See below)	2 FRU

* Based on which one applies to your center, please refer to **SI B01 01 20** or **B01 07 20** for the applicable procedure for documenting, claiming, and explaining, on the RO and in the claim comments, your diagnosis work time (WT), job/repair work time (WT), and the vehicle repairs your center performed, unless otherwise required by State law.

And, as applicable:

Labor Operation	Description	Labor Allowance
51 74 600	Replace the upper air flap	Refer to AIR
Or:		
51 74 601	Replacing bottom air duct	Refer to AIR
Or:		
51 74 602	Replace upper air flap and air duct	Refer to AIR
Or:		
51 74 610	Replace upper air flap control active	Refer to AIR
Or:		
51 74 620	Replace upper air flap control active and air duct lower	Refer to AIR

Refer to AIR for the corresponding flat rate unit (FRU) allowances for the above.

Work time labor operation codes 61 00 006, 51 99 000, 00 58 000 and 00 58 500 are not considered Main labor operations.

Previous Customer-Pay Repairs – Limited Warranty Extension Reimbursement

BMW of North America, LLC (BMW NA) will provide reimbursement for qualifying customer-pay repairs that were performed on an eligible vehicle prior to the release of this component-specific limited warranty extension.

Customer-pay repairs are subject to the same vehicle eligibility requirements, limitations, and exclusions that apply to the BMW New Vehicle Limited Warranty for Passenger Cars and Light Trucks.

Repairs that Do Not Qualify for Reimbursement

Repairs performed on ineligible vehicles, eligible vehicles operated and repaired outside the United States and Puerto Rico, and/or the diagnosis and repair of other unrelated issues are not covered by this component-specific limited warranty extension. This exclusion also applies to repairs, including consequential, that were performed using non-genuine BMW parts and/or used passenger car or light truck parts.

Requesting Reimbursement for a Previous Repair That Qualifies

For a customer to request reimbursement for a qualifying customer-pay repair performed either by an authorized BMW center or independent repair shop located in the United States (including Puerto Rico), please have him/her submit his/her reimbursement request online at www.BMW-RP.com under the following reference:

- **B-ELWR 2021 Active Air Flaps G30 XB1H 15Y150M**

Reimbursement Request Procedure

The online process is initiated by attaching/sending PDF files of the supporting documentation for the prior repair.

The letter also includes alternative methods to request reimbursement, either through the mail or by fax as described below:

BMW Customer Reimbursement Center

Attention: B-ELWR 2021 Active Air Flaps G30 XB1H 15Y150M
P.O. Box 54067
Hurst, Texas 76054

Fax number: 877-434-2992

Please allow 4-6 weeks for processing your request.

Should you have any questions concerning this reimbursement process, please call 1-844-857-0341.

FEEDBACK REGARDING THIS BULLETIN

Technical Feedback	To submit feedback for the technical topics of this bulletin: Submit your feedback in the rating box at the top of this bulletin
Warranty Feedback	To submit feedback for the CLAIMS section of this bulletin: Submit an IDS ticket to the Warranty Department, or use the chat available in the Warranty Documentation Portal
Parts Feedback	To submit feedback for the PARTS section of this bulletin: Submit an IDS ticket to the Parts Department



BMW

47911 HALYARD DRIVE
STE. 200
PLYMOUTH, MI 48170
DO NOT MAIL REPAIR ORDERS TO THIS ADDRESS

017305-T1-P1-000001

Name
Address
City ST Zip Code



September 2021

This **“Important Limited Warranty Information,”** effective with the date listed above, applies to the BMW model with the Vehicle Identification Number (VIN) of **WBAJA9C53JB12345**

Dear BMW Owner/Lessee:

BMW is committed to delivering the ultimate in product satisfaction to our customers.

Towards that end, BMW is extending the limited warranty for the:

- **Front Grille Upper/Lower Active Air Flaps (G30 XB1H)**

On the above-referenced vehicle to:

- **15 years/150,000 miles, as determined by your vehicle’s original in-service date.**

This “component-specific” limited warranty extension applies to defects in materials or workmanship. This coverage is subject to the same vehicle eligibility requirements, limitations, and exclusions that apply to the BMW New Vehicle Limited Warranty for Passenger Cars and Light Trucks.

Note: If the BMW 530e sedan referenced above is currently registered in the State of California (CA), or another State that has fully adopted the State of California TZEZ regulation (CT, ME, MD, MA, NJ, NY, OR, RI and VT), the standard emissions-related coverage for the Front Grille Upper/Lower Active Air Flaps under the terms of this regulation is 15 years/150,000 miles.

This is notice of a “limited warranty extension.” This is not a notice of a Recall or Service Action.

If a repair to this component is required, please contact your nearest authorized BMW center in the United States or Puerto Rico to schedule an appointment.

Your BMW center will confirm your vehicle’s eligibility and review the scope of the repairs to determine if this extended limited warranty coverage applies. After vehicle inspection and diagnosis, eligible repair work will be performed by the authorized BMW center free of charge.

Repairs performed on ineligible vehicles, eligible vehicles operated and repaired outside the United States and Puerto Rico, and/or the diagnosis and repair of other unrelated issues are not covered by this limited warranty extension. This exclusion also applies to repairs, including consequential, that were performed using non-genuine BMW parts and/or used passenger car or light truck parts.

The integrity of our products is essential to BMW’s success and our customers’ trust. We are determined to exceed your expectations and hope this warranty extension further enhances your ownership experience.

Sincerely,

BMW of North America, LLC

Company
BMW of North America, LLC
BMW Group Company

Mailing Address
PO Box 1227
Westwood, NJ
07675-1227

Telephone
(800) 831-1117

E-mail
Customerrelations@
bmwusa.com

Website
www.bmwusa.com



B-ELWR 2021 G30 XB1H Active Air Flaps 15Y150M

Previous Customer-Pay Repairs – Limited Warranty Extension Reimbursement

BMW of North America, LLC

September 2021

VIN WBAJA9C53JB12345

For the BMW model with the Vehicle Identification Number (VIN) listed above, BMW of North America, LLC (“BMW NA”) will reimburse “qualifying customer-pay repairs” that were performed prior to the release of this component-specific limited warranty extension.

Customer-pay repairs are subject to the applicable vehicle and coverage eligibility requirements, exclusions and limitations that apply to the BMW New Vehicle Limited Warranty for Passenger Cars and Light Trucks.

Repairs that Do Not Qualify for Reimbursement

Repairs performed on ineligible vehicles, eligible vehicles operated and repaired outside the United States and Puerto Rico, and/or the diagnosis and repair of other unrelated issues are not covered by this limited warranty extension. This exclusion also applies to repairs, including consequential, that were performed using non-genuine BMW parts and/or used passenger car or light truck parts.

Requesting Reimbursement for a Previous Repair That Qualifies

If you previously had a “qualifying customer-pay repair” performed either by an authorized BMW center or independent repair shop located in the United States (including Puerto Rico), please submit your reimbursement request “online” at www.BMW-RP.com under the following reference:

Covered Component Code

B-ELWR 2021 Active Air Flaps G30 XB1H 15Y150M

To initiate the online process, you will be asked to attach PDF files of the required documentation as outlined in the reimbursement checklist on the next page.

Alternative Method to Request Reimbursement

Alternatively, you may mail or fax your request and documentation to:

BMW Customer Reimbursement Center
Attention: B-ELWR 2021 Active Air Flaps G30 XB1H 15Y150M
P.O. Box 54067
Hurst, TX 76054

Fax number: 877-434-2992

Please allow 4-6 weeks for processing your request.

Should you have any questions concerning this reimbursement process, please call 1-844-857-0341.

B-ELWR 2021 Active Air Flaps G30 XB1H 15Y150M



G30 XB1H Active Air Flaps: Limited Warranty Extension to 15 Years/150,000 Miles

Previous Customer-pay Repair Reimbursement – Documentation Checklist

BMW of North America, LLC

Reimbursement is available to the BMW Owner/Lessee who incurred the expense.

When submitting a reimbursement for a previous repair, please provide **legible copies** of the following documentation and include your VIN, name, address, and your preferred contact telephone number(s):

Repair Order (RO) or Invoice

This document should include the following information:

- Customer name and address
- Vehicle Identification Number (“VIN”)
- The date of repair
- The mileage when the repair was performed
- Itemized breakdown of the labor charges for all repairs* including diagnosis
- Itemized breakdown of the parts, including any miscellaneous items, billed for all repairs*

*For repair orders containing multiple repair line items, only the specific line-item expenses that relate to the component that is covered by this extended limited warranty will be considered for reimbursement.

Proof of Payment

Please provide a copy of at least **one** of the following items as valid proof of payment:

- Repair order (RO)/invoice stamped and dated as “PAID”
- Copy of a cancelled check
- Copy of a signed credit/debit card receipt
- Copy of a credit/debit card statement

Determining if an eligible vehicle’s repair qualifies for reimbursement:

Please use the following questions to review your repair order documentation prior to submitting a reimbursement request:

1. Why was the vehicle brought into the repair facility?
2. What was the repair facility's diagnosis?
3. What did the repair facility do to correct the concern, and does it qualify?



Frequently Asked Questions (FAQ) – Limited Warranty Extension

1. Which BMW Group models in the U.S. are potentially eligible for this component-specific Limited Warranty Extension?

E-Series	MY	Model Description	Engine
G30	2018 - 2019	530e iPerformance	XB1H
G30	2018 - 2019	530e xDrive iPerformance	XB1H

2. How do I determine if my vehicle falls under the State of California TZEV regulation?

Eligible BMW 530e sedans that are registered in the State of California (CA), or another State that has fully adopted the State of California TZEV regulation (CT, ME, MD, MA, NJ, NY, RI and VT); the Front Grille Upper/Lower Active Air Flaps is covered under the terms of this emission-related regulation for 15 years/150,000 miles, whichever occurs first.

For all remaining eligible BMW 530e sedans, the Front Grille Upper/Lower Active Air Flaps is covered under the terms of this component-specific limited warranty extension for 15 years/150,000 miles, whichever occurs first.

Note: For the MY 2018 G30 XB1H vehicles, this 15/150 coverage replaces the extended coverage statement that was sent to you in a prior notification letter.

4. What is the specific issue related to the Front Grille Upper/Lower Active Air Flaps?

If an Active Air Flap malfunction occurs, a Check Control Message (CCM) can display, and/or the Malfunction Indicator Lamp (MIL) may illuminate. Or, visually, the flaps are mechanically out of sync (one side is open while the other side remains closed).

5. What should I do if I notice this condition with my vehicle?

Please contact an authorized BMW center in the United States (including Puerto Rico) to have your vehicle inspected and, if necessary, repaired.

6. What will happen if there is a problem with the Front Grille Active Air Flaps?

If it is determined that the Active Air Flap(s) issue is due to a defect in materials or workmanship, it will be repaired free of charge under the terms of the 15 year/150,000-mile limited warranty coverage that applies to your vehicle.

Issues and repairs related to outside influences are not included under this component-specific limited warranty extension.

Note: During the extended limited warranty coverage period (Eligible vehicles that are beyond the 4 year/50,000 mileage New Vehicle Limited Warranty coverage), Active Air Flap repairs for surface appearance/cosmetic-related defect issues are not covered.

